

# PHYSICS OF NUCLEAR REACTORS

Broad topic	Lecture title
Basic principles of NPP	Introduction / Review of nuclear physics
	Interaction of neutrons with matter
	Nuclear fission
	Fundamentals of nuclear reactors
	LWR plants
Modeling the beast	The diffusion of neutrons - Part 1
	The diffusion of neutrons - Part 2
	Neutron moderation without absorption
	Neutron moderation with absorption
	Multigroup theory
	Element of lattice physics
	Neutron kinetics
	Depletion
Reactor Concepts Zoo	Advanced LWR technology
	Breeding and LFR
	<b>AGR, HTGR</b>
	Channels, MSR and thorium fuel
Review session	

- Gas cooled reactors
- High Temperature Gas Cooled Reactors

- Concept
  - Thermal (prototypes existing) or fast reactors (no prototypes)
  - Gaseous coolant combined with a solid moderator and fuel located in channels in the moderator block, all inside a pressure vessel
- Advantages of the concept
  - Gaseous coolants much less corrosive, low to very low activation
  - Low neutron absorption by gaseous coolants, natural uranium reactors possible (in combination with graphite or heavy water)
  - High temperature reactors are feasible (in case of helium as coolant)
  - Refueling during operation possible in some concepts (some gas-cooled reactors were used to breed weapon grade plutonium...)
- Disadvantage
  - Low power density, bad heat transfer properties of gaseous coolant

Calder Hall (1956) = Magnox Reactor

Coolant:  $\text{CO}_2$

Moderator: Graphite

Power:  $61 \text{ MW}_{\text{el, brutto}}, 270 \text{ MW}_{\text{th}}$

Fuel: Natural uranium

Cladding: Magnox

**$\text{CO}_2$ : up to 2.7 MPa  
up to 410 °C**  
(Calder Hall: 0.7 MPa / 336 °C)

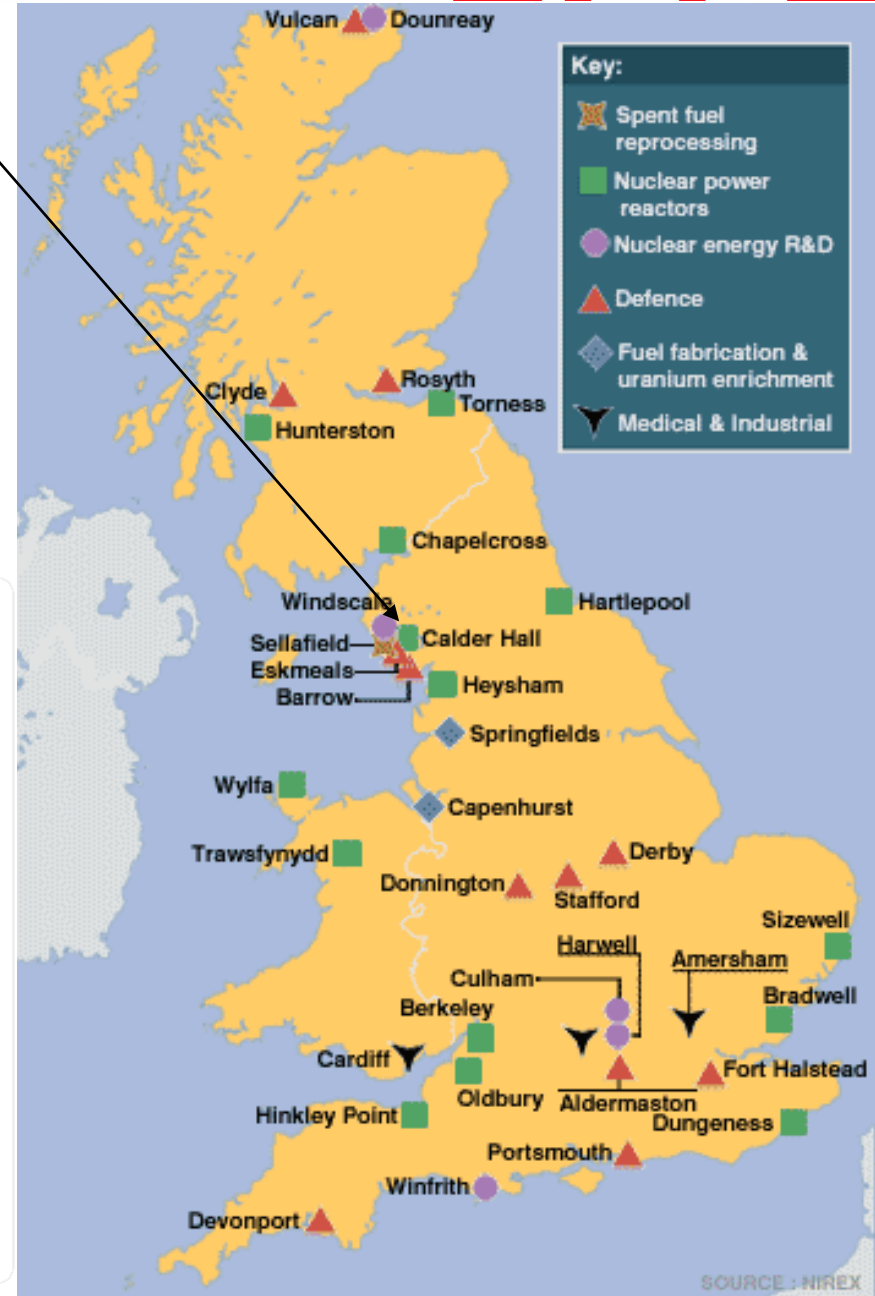
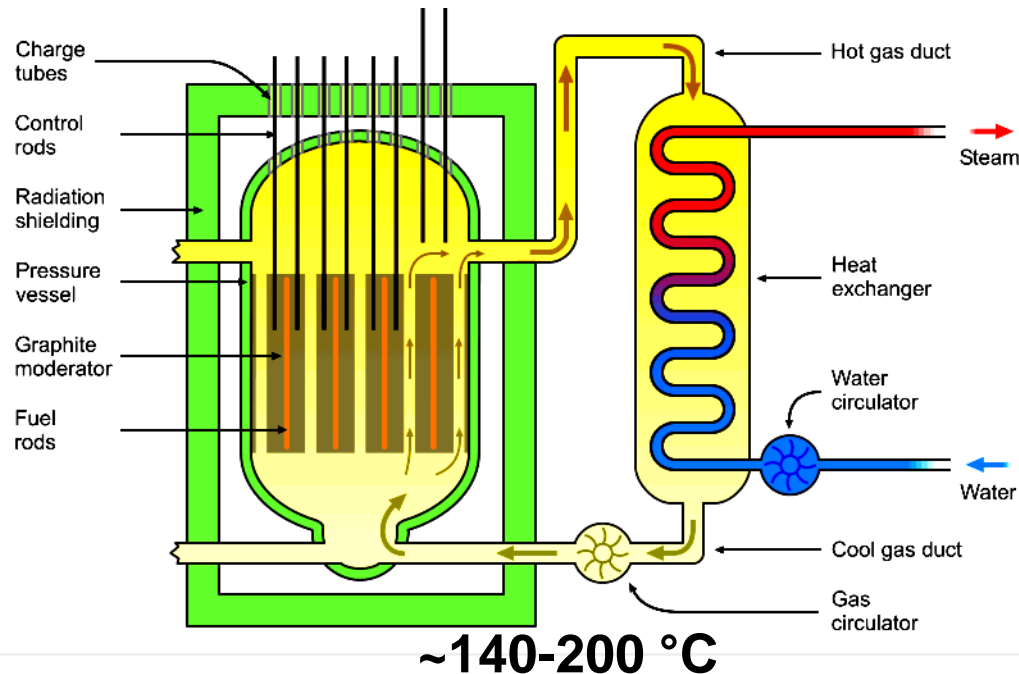

## MAGNOX fuel

Length: ~ 1 m

Diameter: ~ 50 mm

Fuel: Natural uranium

Cladding: Magnox = Mg (99 %)  
+ Al, Be, Ca, Fe, Mn, Ni, Pb, Sn

Melting point: 650 °C

$T_{\text{clad,max}} = 470 \text{ °C}$ , otherwise destruction by  $\text{CO}_2 + \text{Mg} \rightarrow \text{CO} + \text{MgO}$

**Magnox = Magnesium non oxidizing**

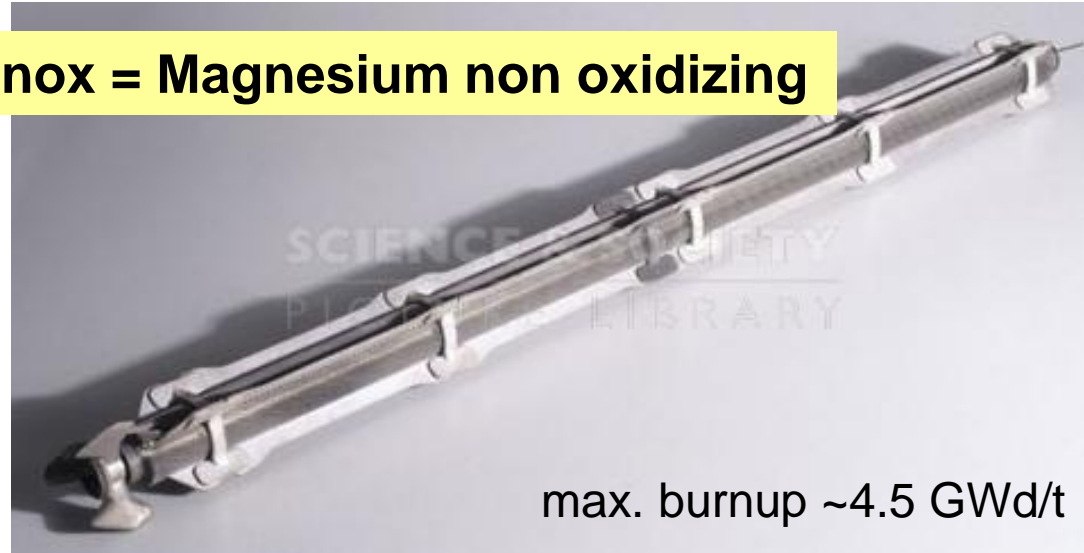

max. burnup ~4.5 GWd/t

## AGR fuel – overcomes temperature limitations of MAGNOX

Length: ~ 1 m

Fuel:  $\text{UO}_2$  (ceramic)  
Pellets

Diameter: ~ 12 mm

Cladding: Stainless steel

Sleeve: Graphite

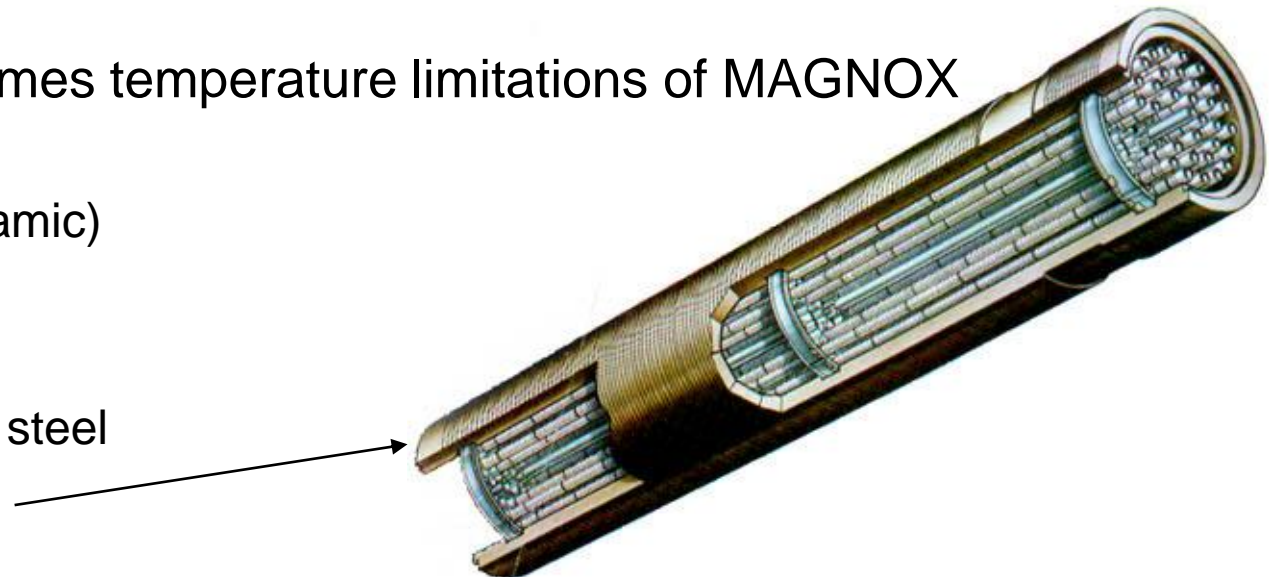

# EARLY MAGNOX REACTORS AND THEIR STEAM GENERATORS

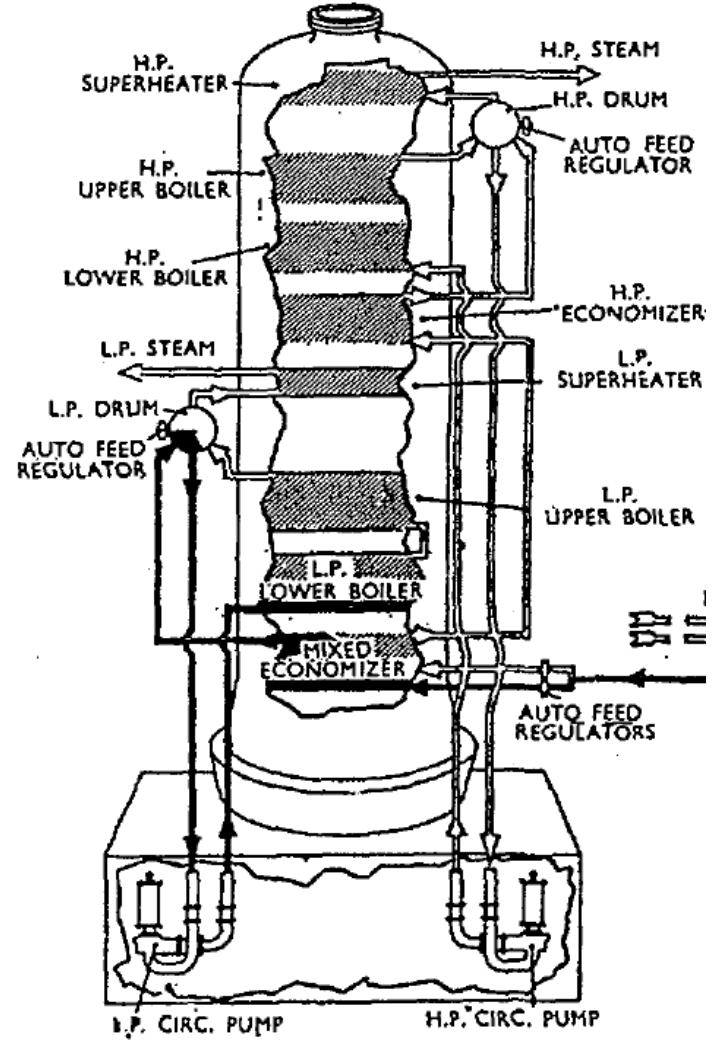
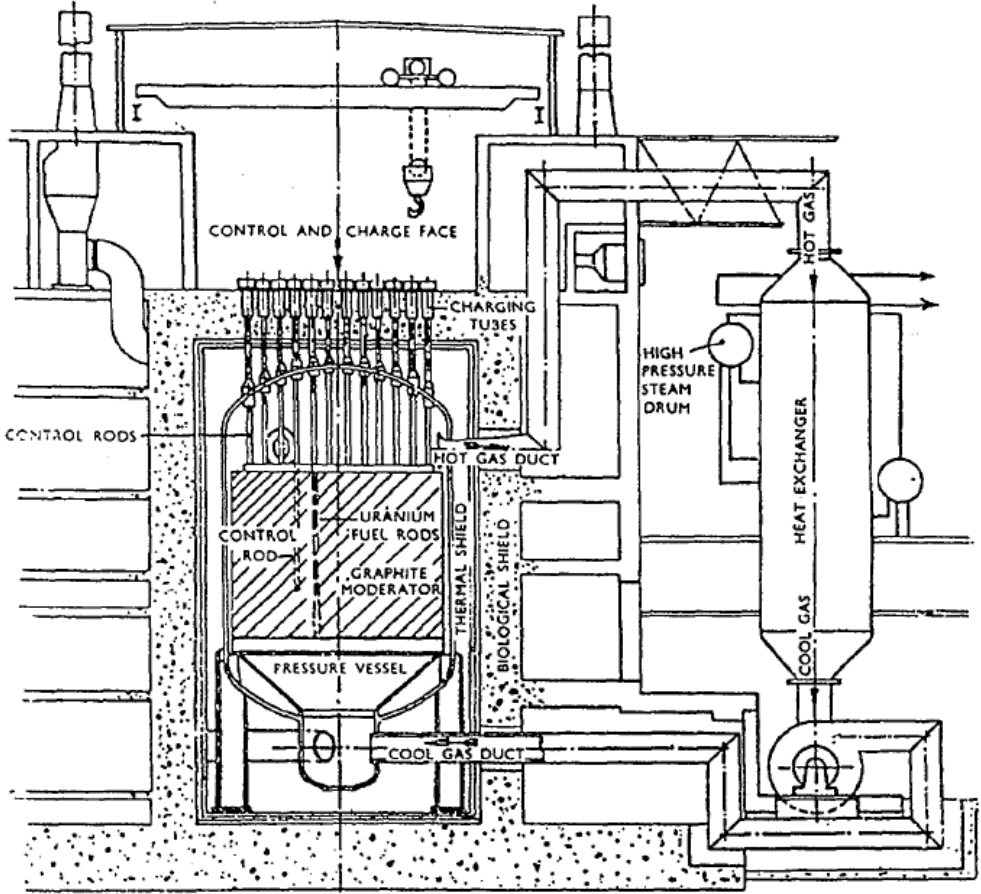

Calder Hall, 46 MWe (4x)  
Berkeley, 139 MWe (2x)

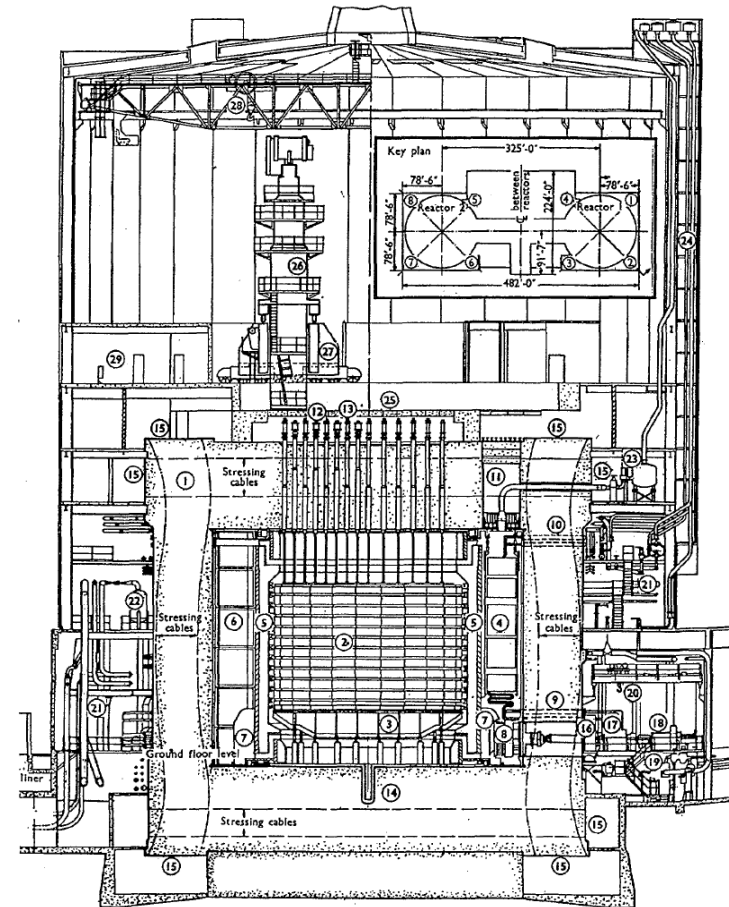
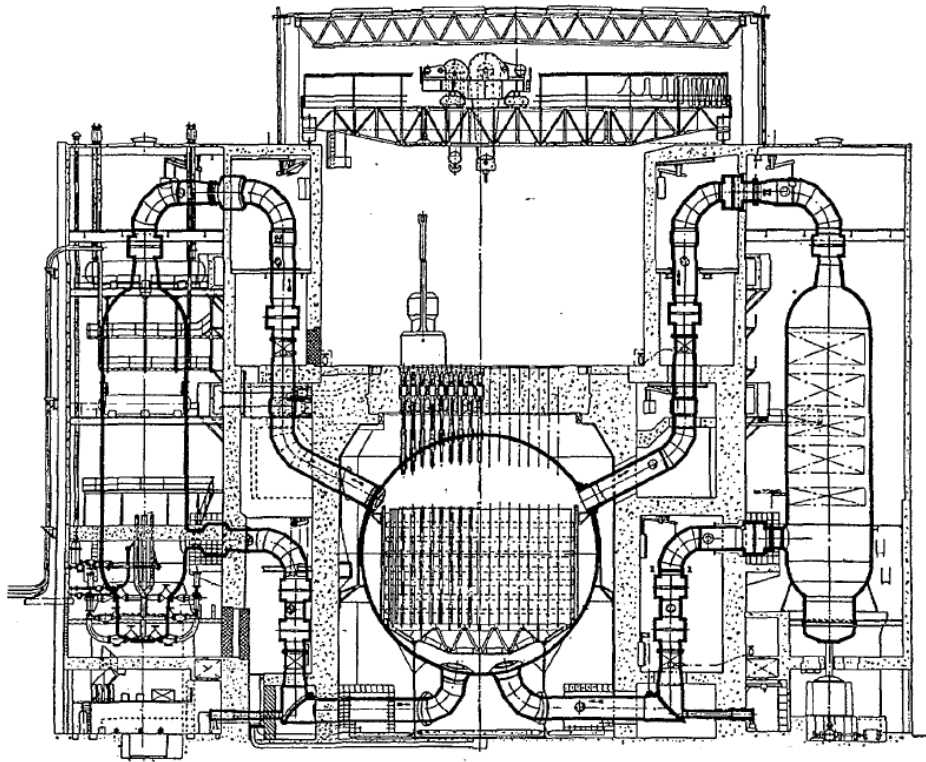

- Bradwell, 150 MWe (2x)
- Hunterston, 160 MWe (2x)
- Dungenes, 275 MWe (2x)
- Hinkley Point, 250 MWe (2x)
- Trawsfynydd, 250 MWe (2x)
- Sizewell, 290 MWe (2x)

Oldbury, 280 MWe (2x)

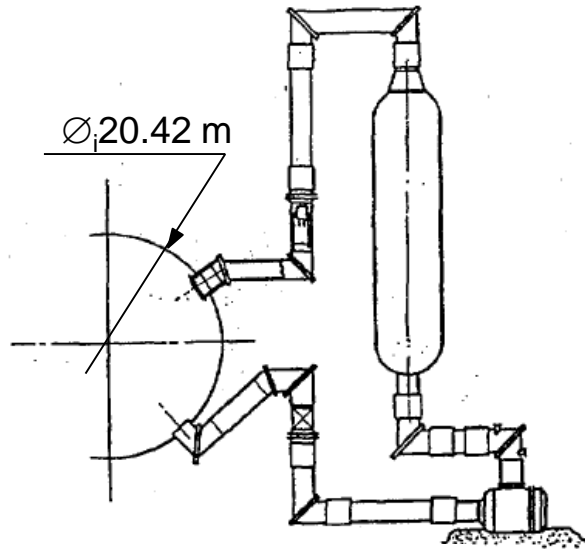

Hinkley Point

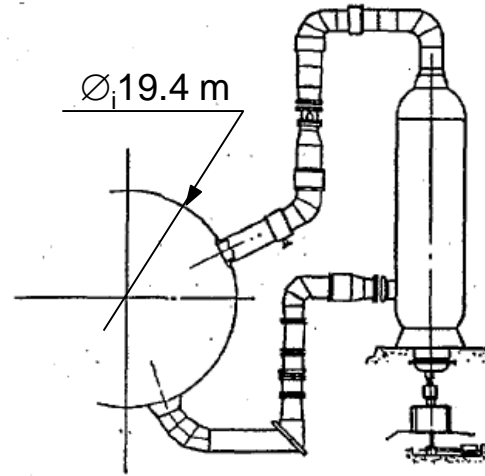

Sizewell

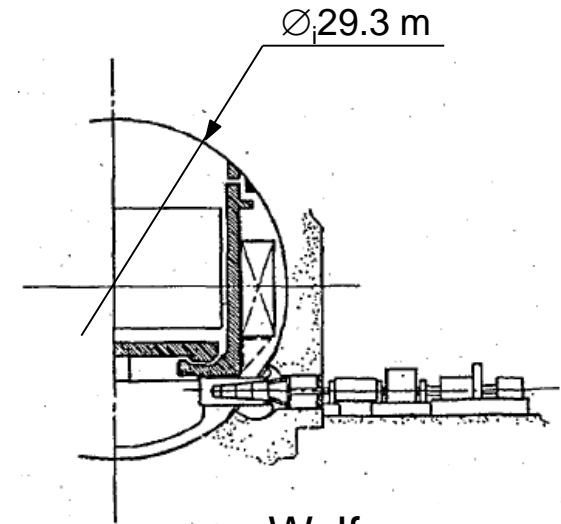

Wylfa

- Spherical steel vessel (12.2 bar)
- External CO<sub>2</sub> circulator
- Steam generator with economizer, evaporator + steam drums, super-heater
- Primary: 180→375 °C, 4536 kg/s
- Secondary: 363 °C, 45.7 bar
- Q<sub>th</sub> = 980 MW (2x)
- Q<sub>el</sub> = 250 MW (2x)

- Spherical steel vessel (17.9 bar)
- CO<sub>2</sub> circulator, integrated in steam generator, shaft sealing
- Steam generator with economizer, evaporator + steam drums, super-heater
- Primary: 214→410 °C, 4470 kg/s
- Secondary: 389 °C, 47.6 bar
- Q<sub>th</sub> = 950 MW (2x)
- Q<sub>el</sub> = 290 MW (2x)

- Spherical pre-stressed concrete vessel (26.2 bar)
- Integrated CO<sub>2</sub> circulator with shaft sealing
- Once-through steam generator, integrated in reactor vessel
- Primary: 247→414 °C, 10'254 kg/s
- Secondary: 410 °C, 46 bar
- Q<sub>th</sub> = 1875 MW (2x)
- Q<sub>el</sub> = 590 MW (2x)

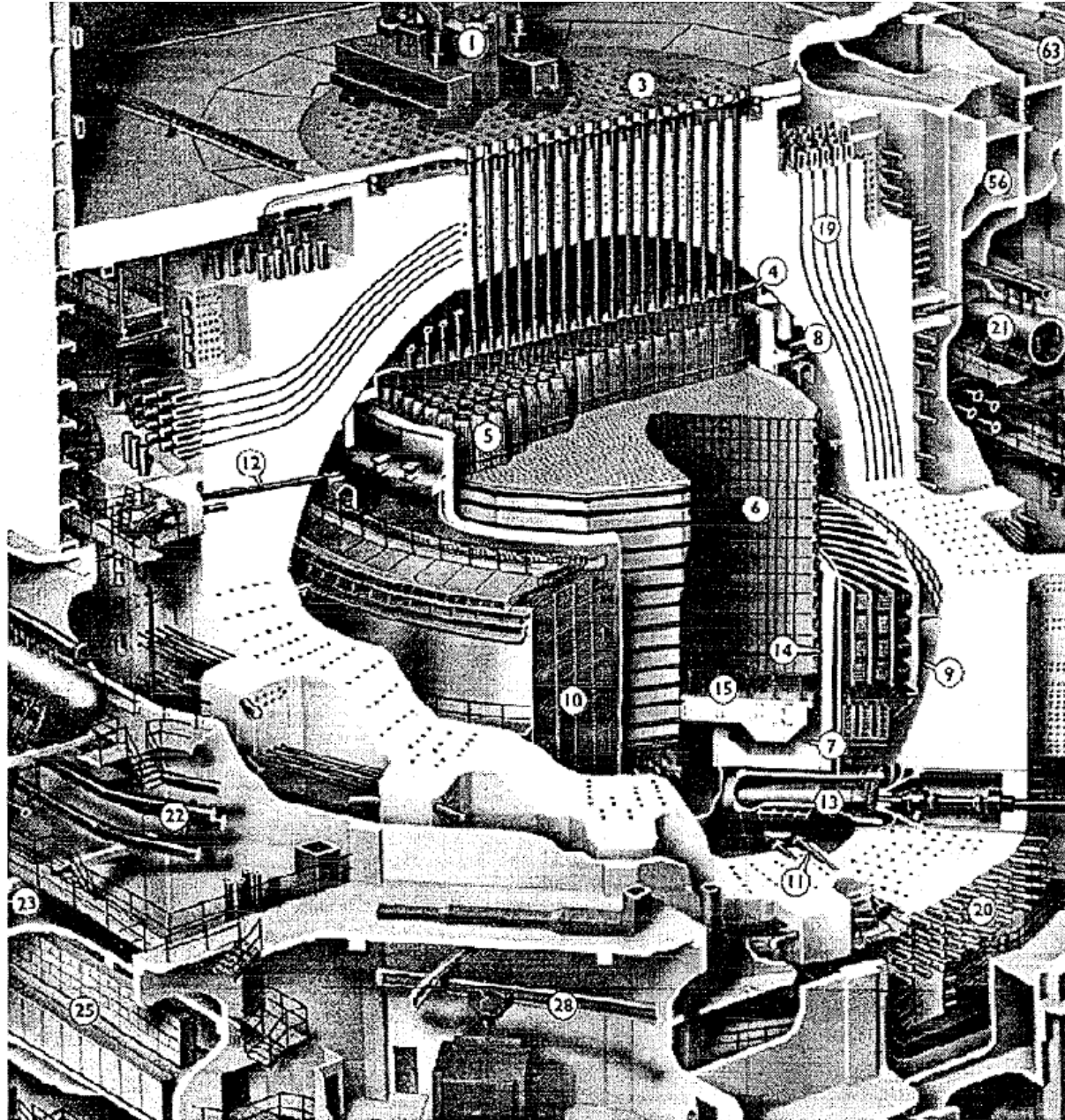

590 MWe  
(2x)

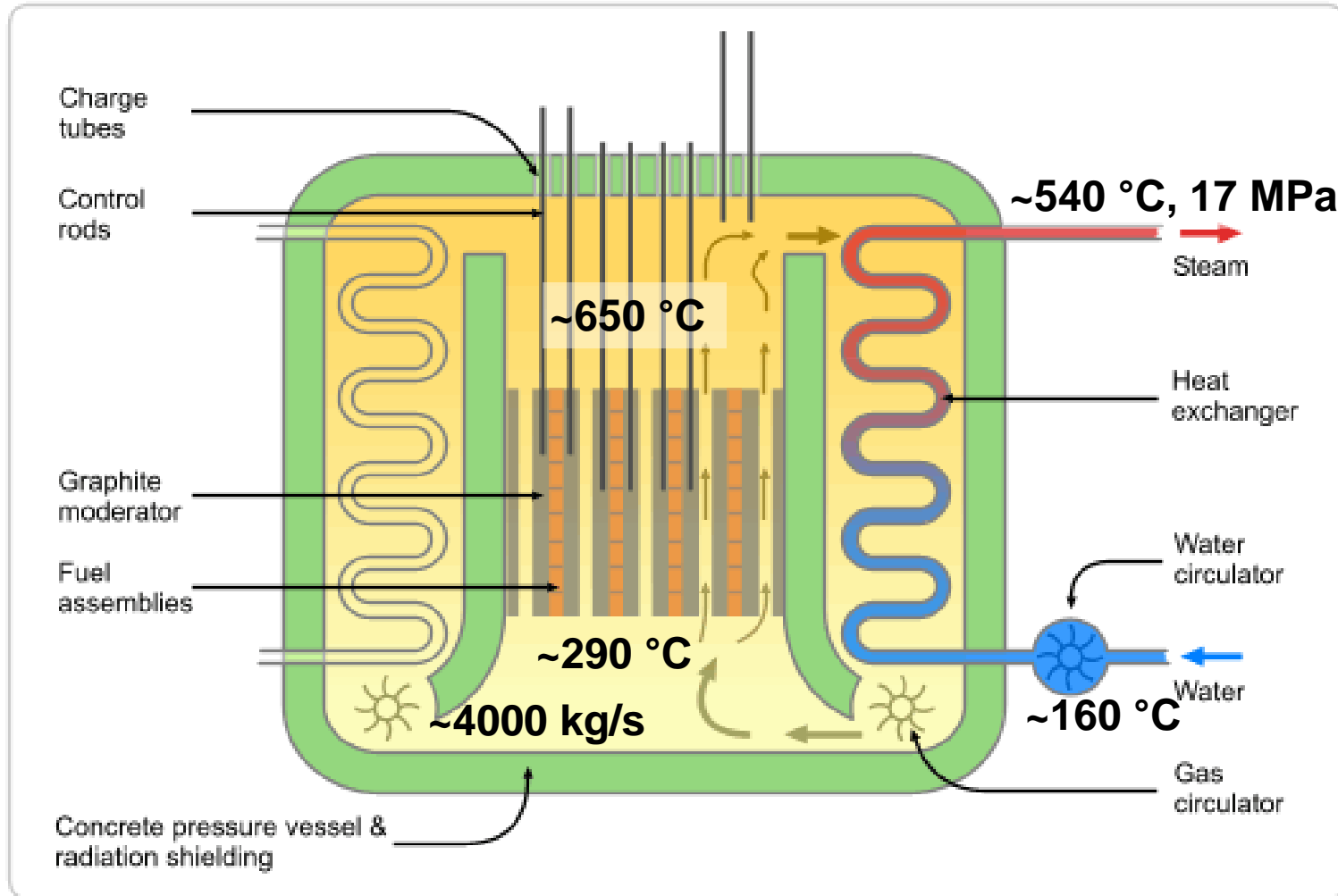

Coolant:  $\text{CO}_2$   
 Moderator: Graphite  
 Fuel:  $\text{UO}_2$ , 2.5 % U-235  
 Cladding: Stainless steel

Uranium mass: ca. 170 t U/GW<sub>el</sub>  
 Pressure (gas): ca. 40 bar  
 Temp. max (gas): ca. 650 °C  
 Max. Power: ca. 600 MW<sub>el</sub>

- 1 Reactor core
- 2 Supporting grid
- 3 Gas baffle
- 4 Circulator outlet gas duct
- 5 Boiler
- 6 Thermal insulation
- 7 Reheat steam penetrations
- 8 Main steam penetrations
- 9 Boiler feed penetrations
- 10 Cable stressing gallery
- 11 Gas circulators
- 12 Steam pipes to turbine

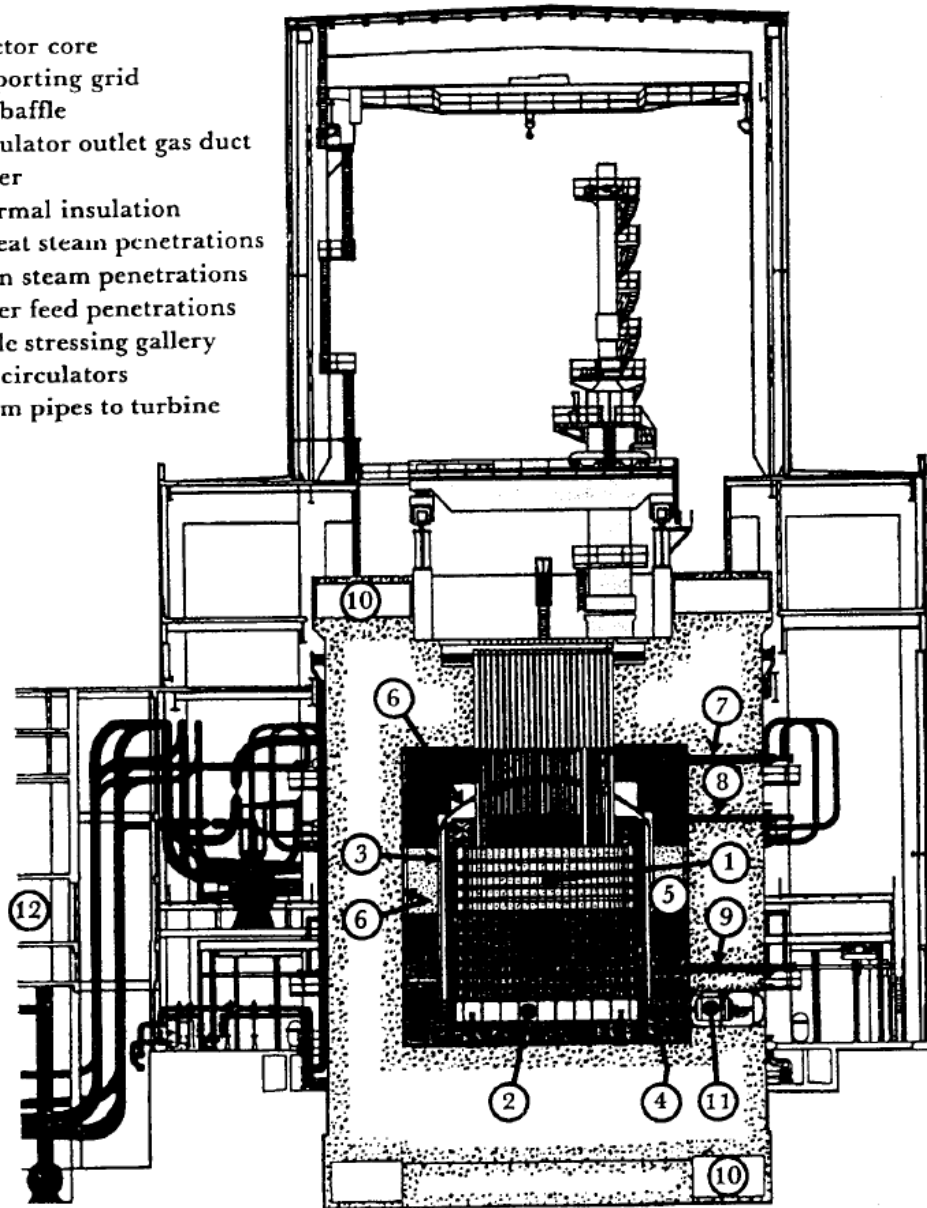

$$Q_{th} = 1623 \text{ MW (2x)}$$

$$Q_{el} = 660 \text{ MW (2x)}$$

Pressure vessel  
 Pre-stressed concrete  
 $D_i = 20.3 \text{ m}$   
 $D_o = 31.9 \text{ m}$   
 $p = 45.7 \text{ bar}$

Gas circulator ( $\text{CO}_2$ )  
 Number: 8  
 Power (total): 42 MW  
 Flow: 4067 kg/s

Primary: 339 → 639 °C  
 Secondary: 158 → 541 °C @ 173 bar

➤ **Goal: Reach reactor outlet temperatures beyond 650 °C**

❖ **Solution: Change from CO<sub>2</sub> to the noble gas helium (pressurized)**

Reasons:

- Increase of reactor outlet temperature → exclude CO<sub>2</sub> redox reactions at higher temperatures (significant above 650 °C)

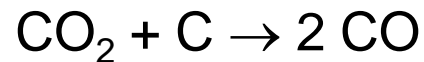

- Enhance heat transfer by gas with better thermal conductivity

**He**      **0.14264 W/(m·K)**

Ne      0.0458 W/(m·K)

Ar      0.01636 W/(m·K)

Kr      0.00883 W/(m·K)

Xe      0.00519 W/(m·K)

Helium best after hydrogen  
(hydrogen is used as coolant  
for the rotor of the generator)

H<sub>2</sub>      0.16835 W/(m·K)

CO<sub>2</sub>      0.01465 W/(m·K)

Purpose 1: Increase thermal plant efficiency by higher heat supply temperature

*e.g. Combined cycle plant*

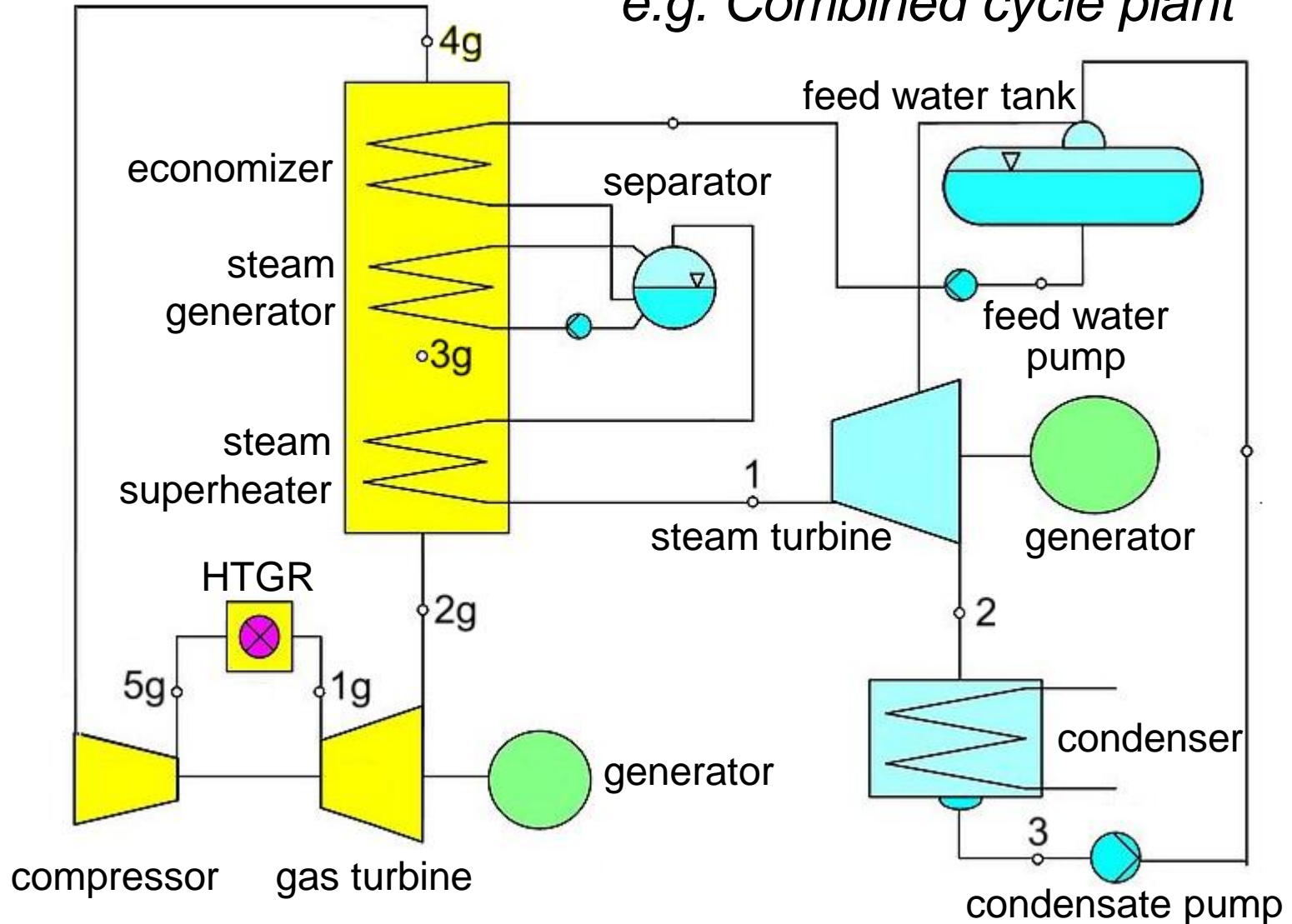

Purpose 2: Provide process heat for chemical reactions  
 e.g. H<sub>2</sub> production by H<sub>2</sub>SO<sub>4</sub> - Iodine process

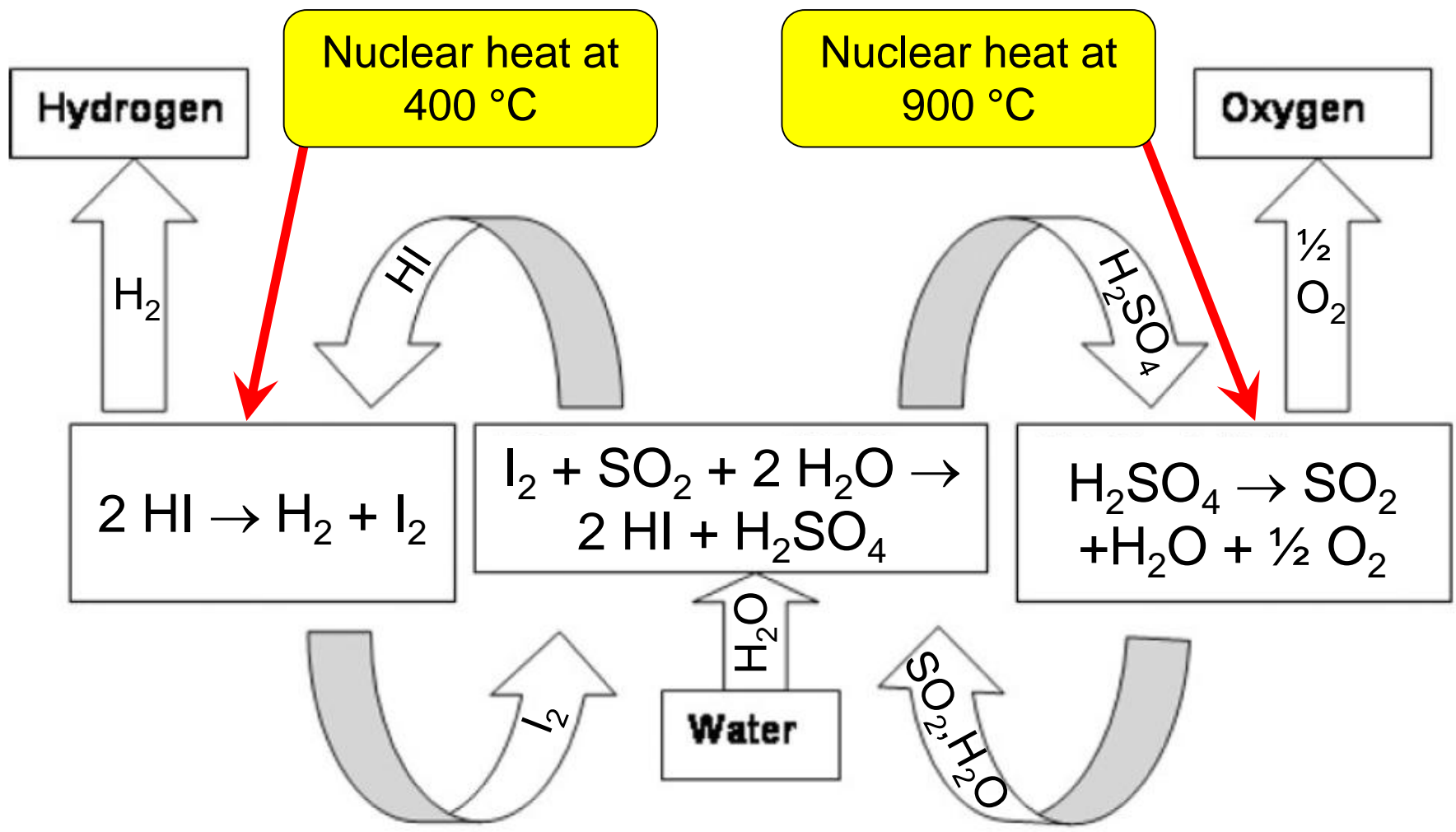

❖ **Improve stability of fuel at high temperatures**

- Introduction of coated particle fuel (coating = barrier against fission product release)
- Use of a chemically inert coolant (noble gas + good heat removal → helium)

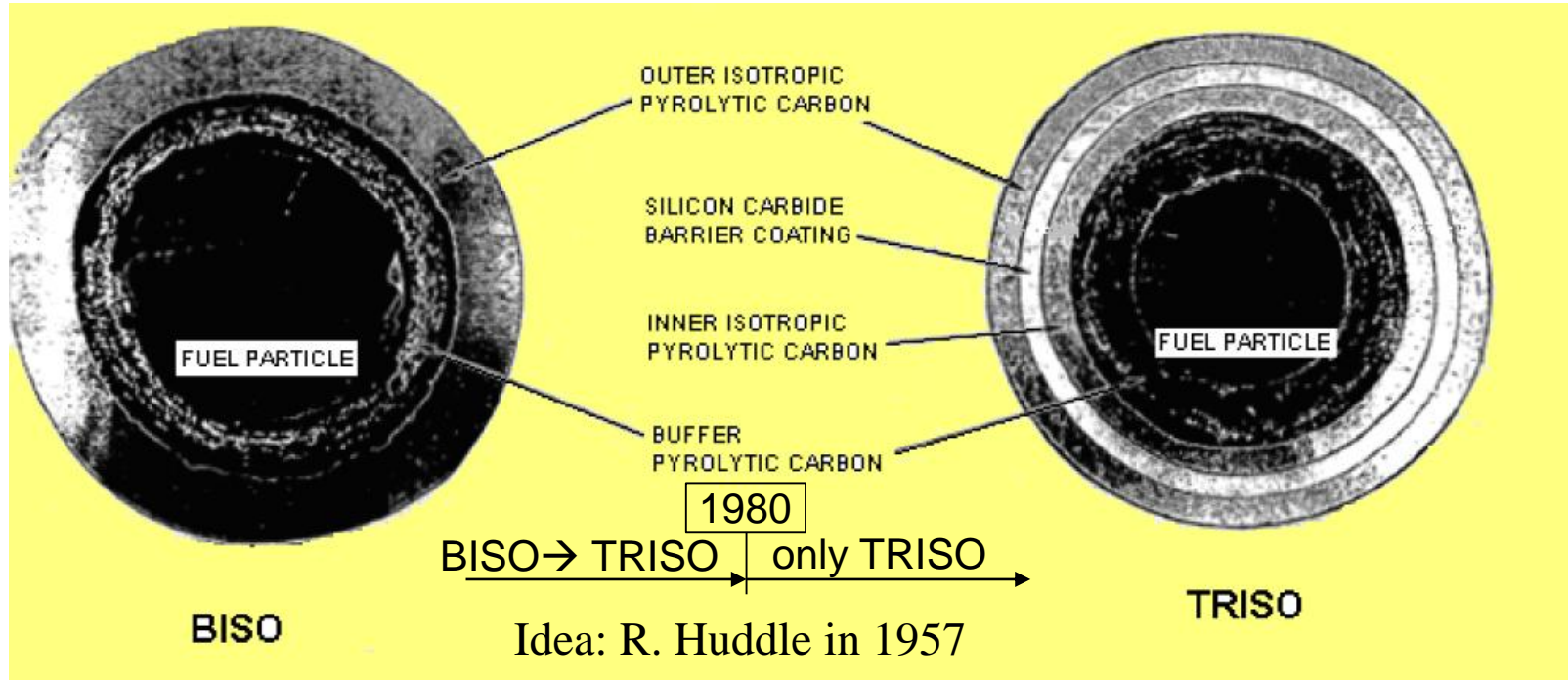

## BISO and TRISO coated fuel particles (General Atomics Co.)

BISO = Bi-coated Isotropic  
 TRISO = Tri-coated Isotropic

Fuel particle = fuel kernel  
 Options:  $\text{UO}_2$ ,  $\text{UCO}$ ,  $\text{UC}$ ,  $\text{UC}_2$  or mixtures  
 $\text{ThO}_2$ ,  $\text{ThC}_2$   
 $\text{PuO}_2$

Examples of the retention capability of BISO and TRISO

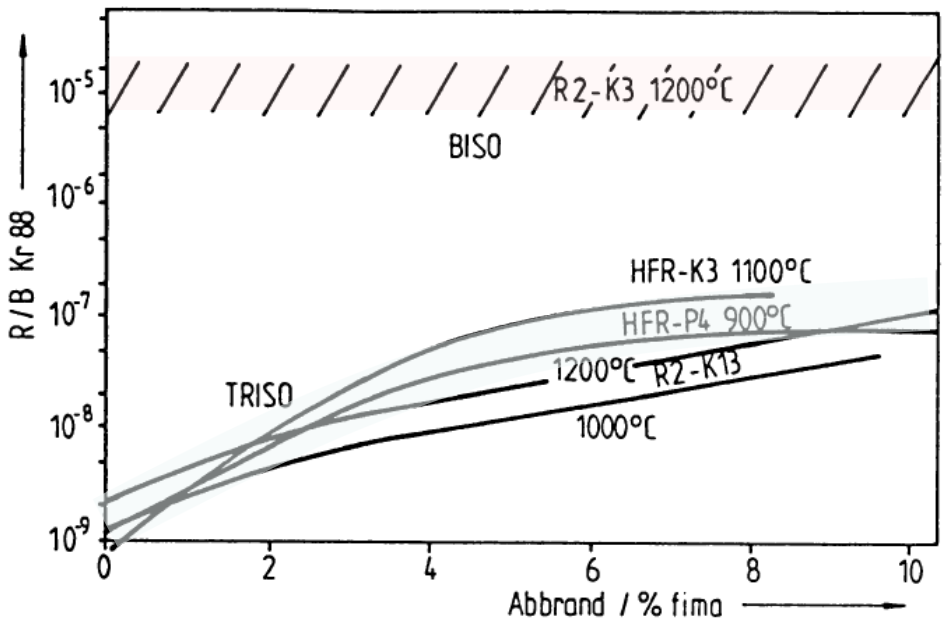

Krypton releases at **normal operation** conditions

→ both BISO and TRISO show acceptable to very good performance

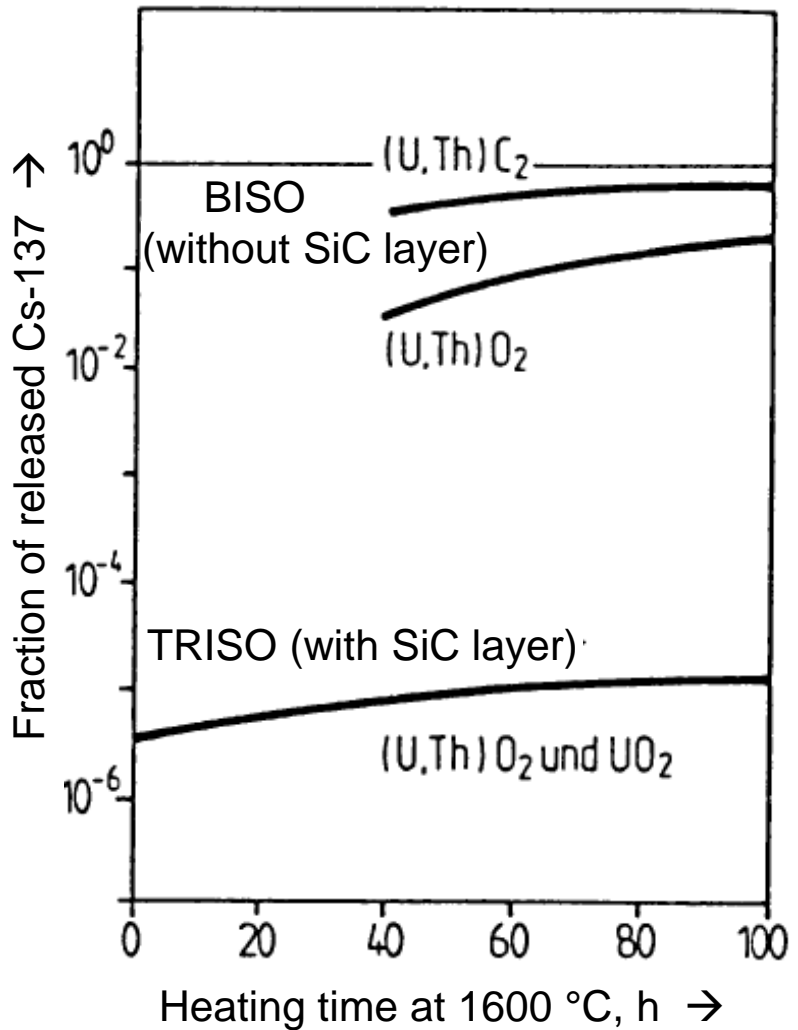

Cs-137 releases at **accident conditions**

→ BISO fails to retain Cs-137  
 → TRISO shows good performance

Aqueous solution of uranyl nitrate  $(\text{UO}_2)(\text{NO}_3)_2$

Droplets of the broth are generated by a 600Hz vibrator

Droplets fall through gaseous  $\text{NH}_3$

into concentrated aqueous solution of  $\text{NH}_3$   
for bulk gelation

Finishing steps:

- Drying at  $80^\circ\text{C}$
- Calcination in air at  $300^\circ\text{C}$  (remove  $\text{CO}_2$ ,  $\text{NH}_3$ ,  $\text{H}_2\text{O}$ )  $\rightarrow \text{UO}_3$
- Reduction to  $\text{UO}_2$  by  $\text{H}_2$  stream at  $1600\text{-}1700^\circ\text{C}$

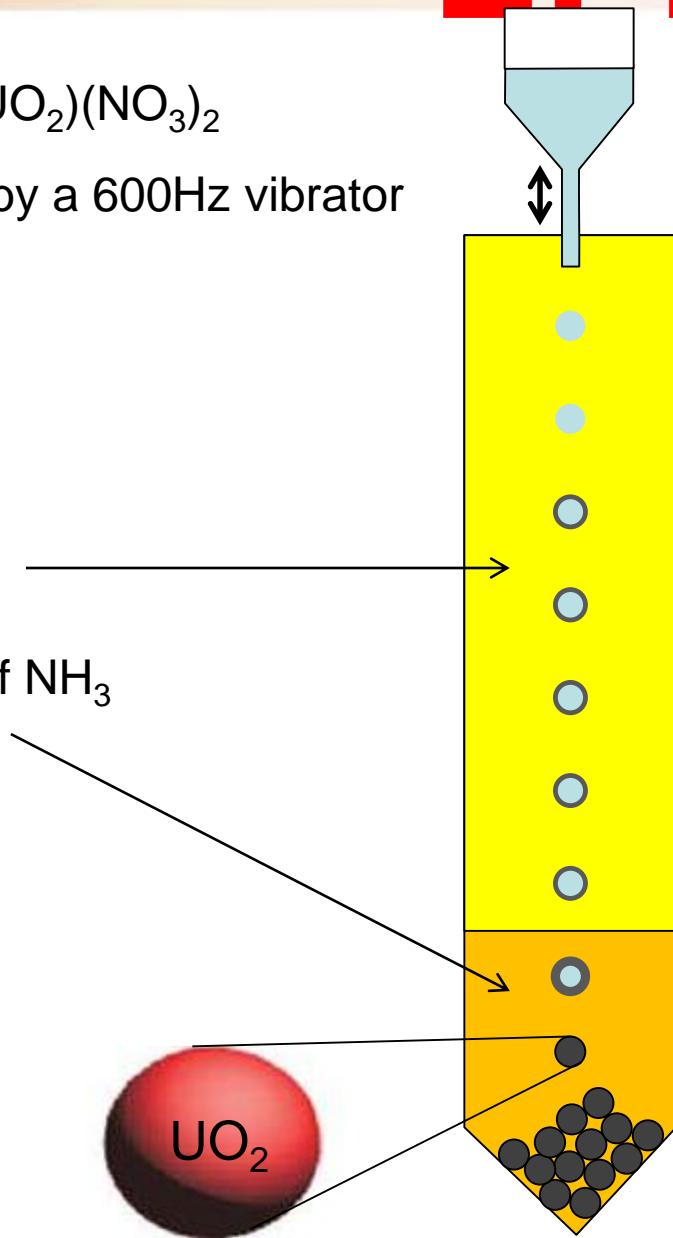

## Fluidized bed reactor

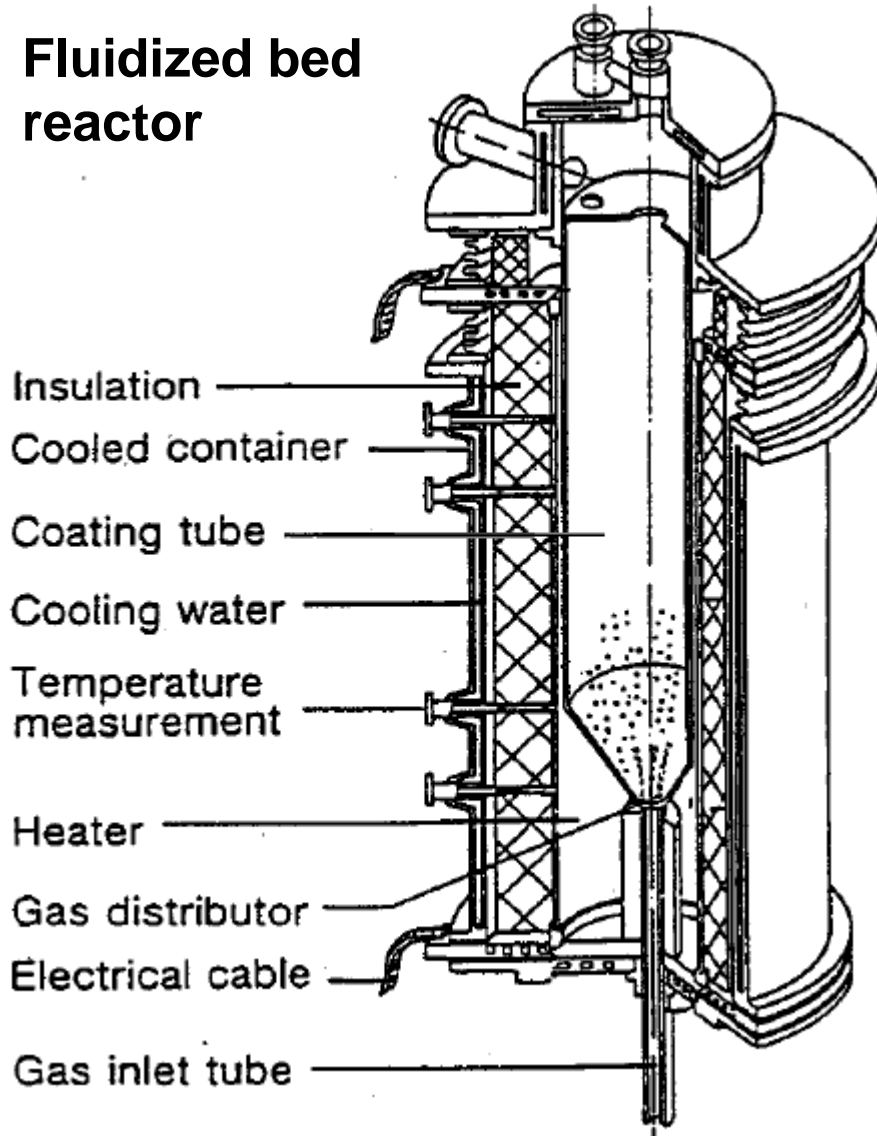

Process:

1. Buffer layer (BL) deposited from a mixture of  $C_2H_2$  and Ar at  $1250^\circ C$
2. IPyC layer deposited from mixture of  $C_2H_2$ ,  $C_3H_6$  and Ar at  $1300^\circ C$
3. SiC layer is deposited from a mixture of  $CH_3SiCl_3$ , and  $H_2$  at  $1500^\circ C$  ( $\sim 0.2 \mu m/min$ )
4. OPyC layer deposited like IPyC

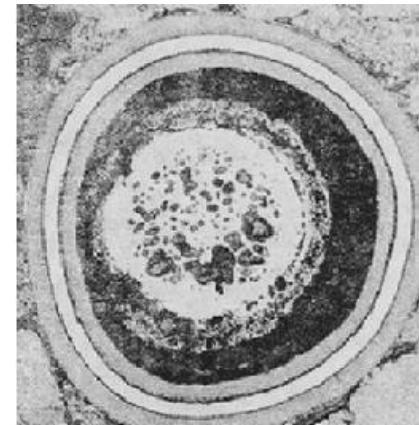

5. Odd-shaped particles eliminated by means of vibrating tables

## Spherical fuel elements



Allow continuous refueling

→ no excess reactivity needed

→ wear while moving through reactor

## Prismatic fuel elements



Only periodic refueling

→ excess reactivity needed

→ no wear during reactor operation

Reactor Type	Power	Operation
<b>Pebble bed reactors</b>		
AVR Germany <b>FZ Jülich</b>	46 MWth/15 MWeI	1966–1988
THTR-300 Germany <b>Hamm-Uentrop</b>	750 MWth/296 MWeI	1985–1989
HTR-10 China <b>Uni Tsinghua</b>	10 MWth	Since 2000
HTR-PM China	2x250 MWth/210 MWeI	since Dec, 2021
<b>Prismatic core</b>		
Peach Bottom 1 US	40 MWeI	1966–1974
Fort St Vrain US	842 MWth/330 MWeI	1976–1988
HTTR Japan	30 MWth	Since 1998
GT-MHR US/Russia	600 MWth/293 MWeI	Point Design

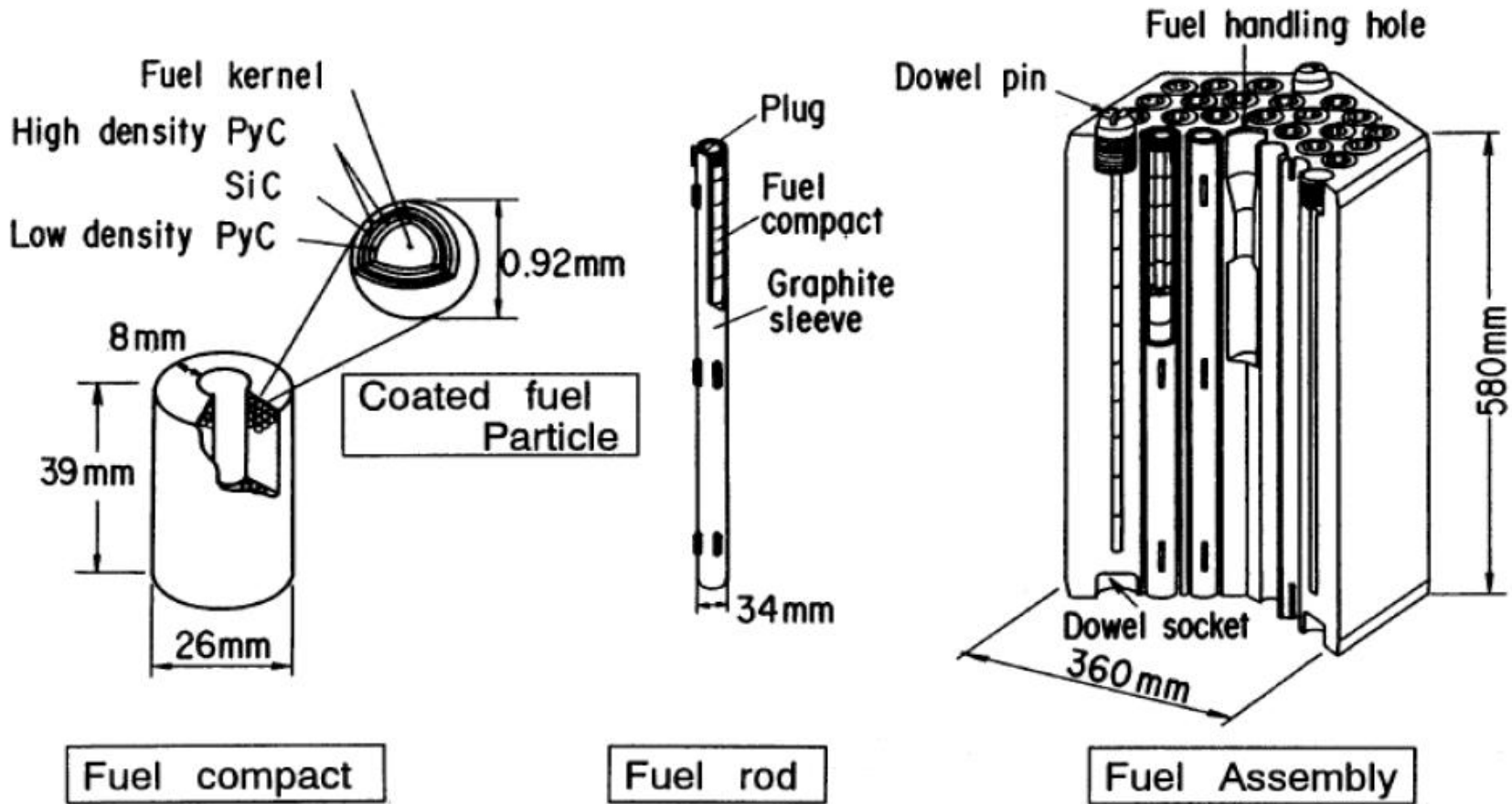

Fuel of the High Temperature Engineering Test Reactor (HTTR) (Japan)

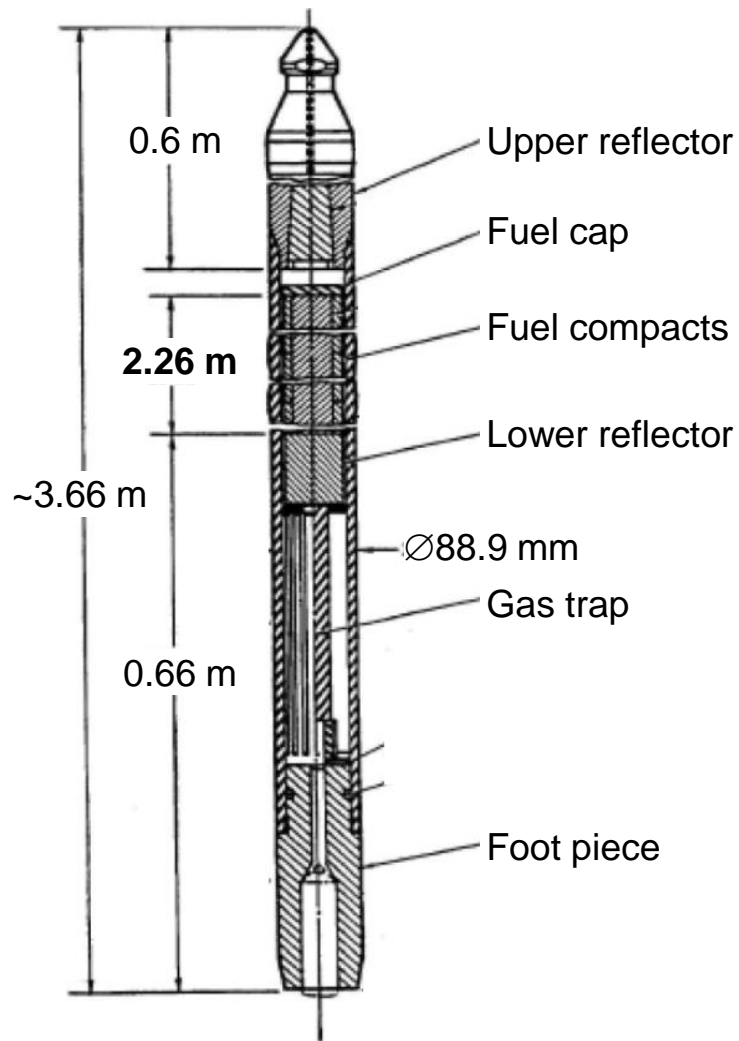

Peach Bottom

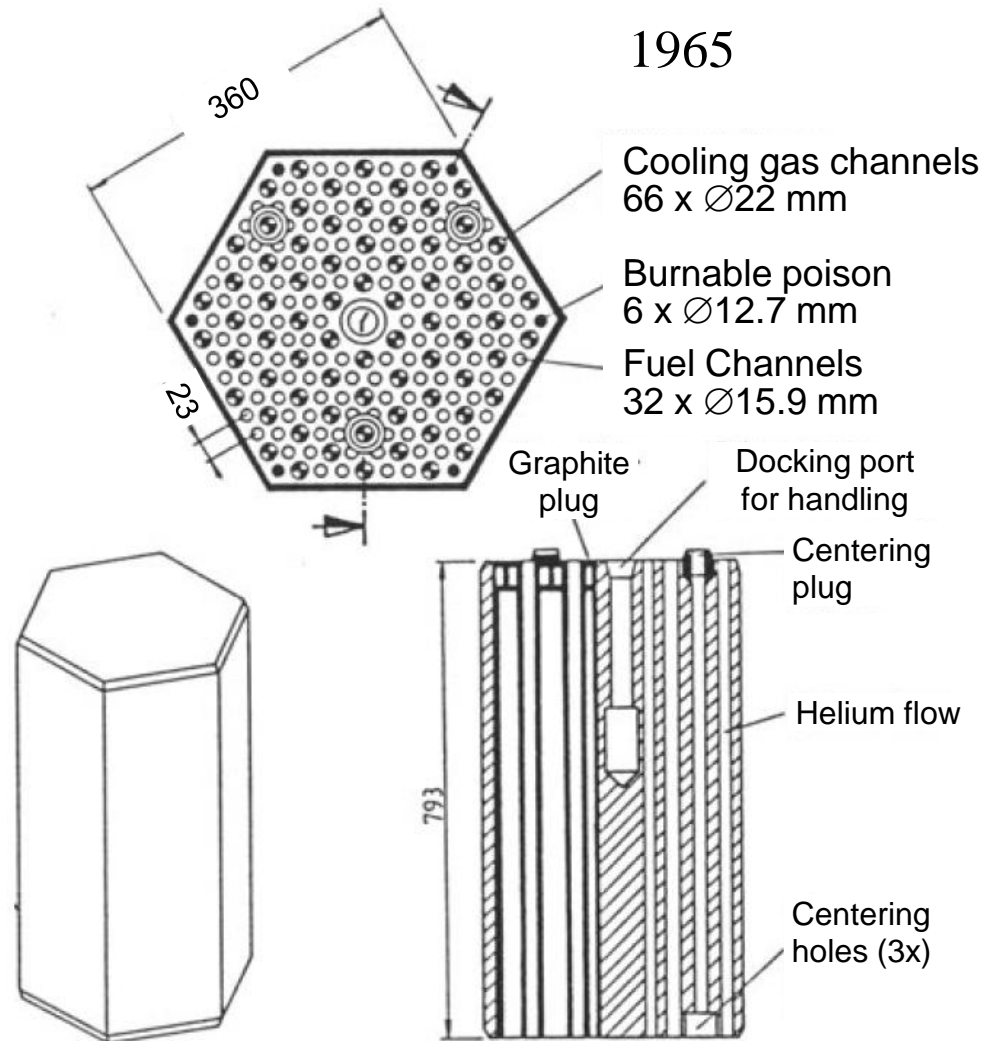

1965

Fort St. Vrain

# HTGR demonstrators with coated particle fuel in US

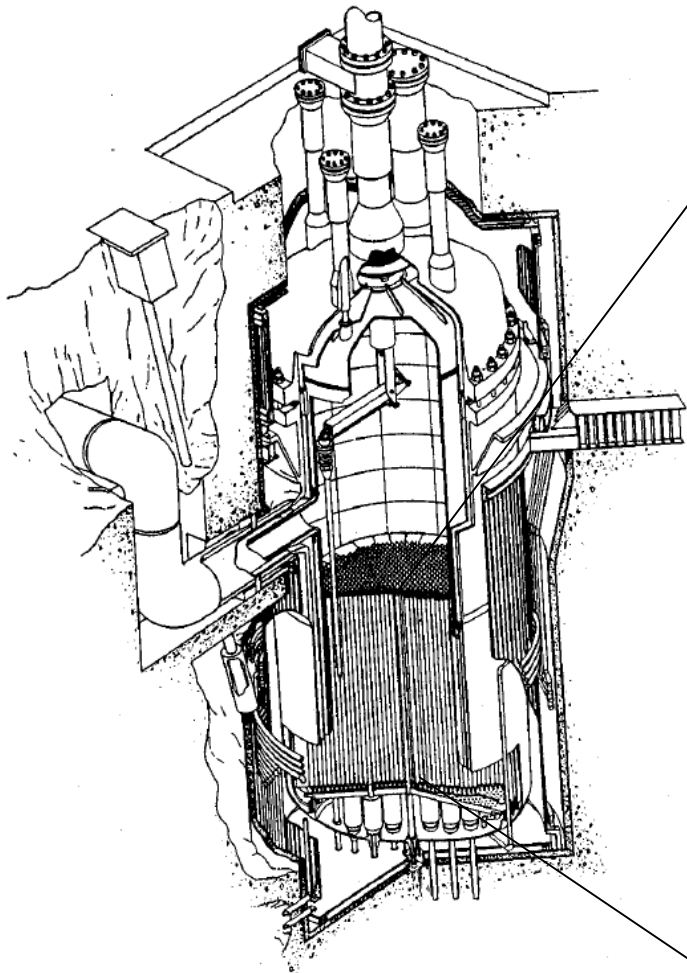

Peach Bottom

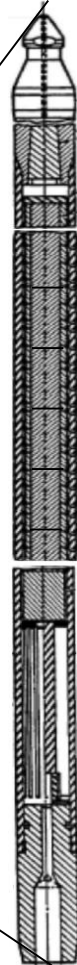

Long cylindric fuel elements

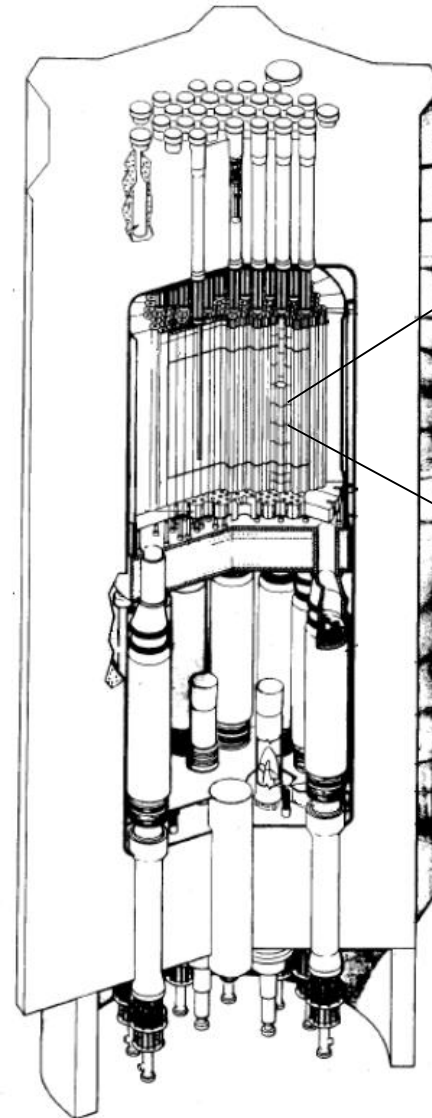

Fort Saint Vrain

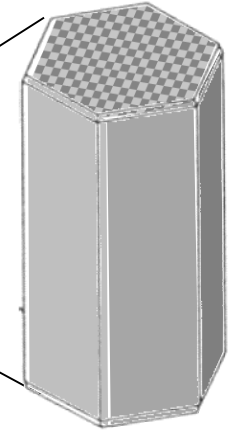

Prismatic fuel elements

1. Mixing **coated particles** with resinated powder of graphite
2. Pre-molding at about 30 MPa and room temperature in silicone rubber molds → **fuel region of pebbles** ( $\varnothing 50$  mm)
3. Add resinated powder in molds to form **fuel-free zone** ( $\varnothing 60$  mm)
4. Isostatic pressing at 300 MPa and room temperature in silicone rubber molds
5. Resin binder carbonization at 800-900°C in inert gas
6. Sintering and extract residual gases and other impurities at 1950°C under vacuum

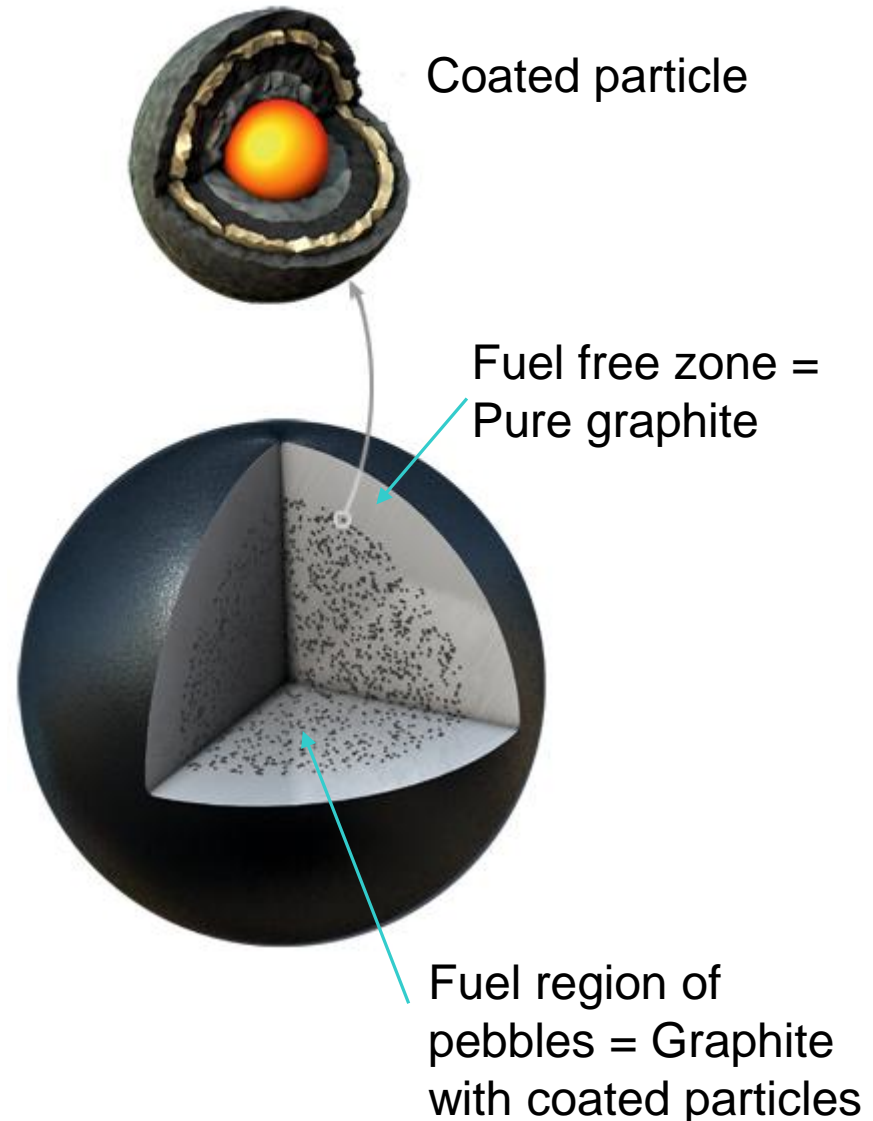

# SCHEME OF A NPP WITH HIGH-TEMPERATURE GAS-COOLED REACTOR (PEBBLE BED REACTOR)

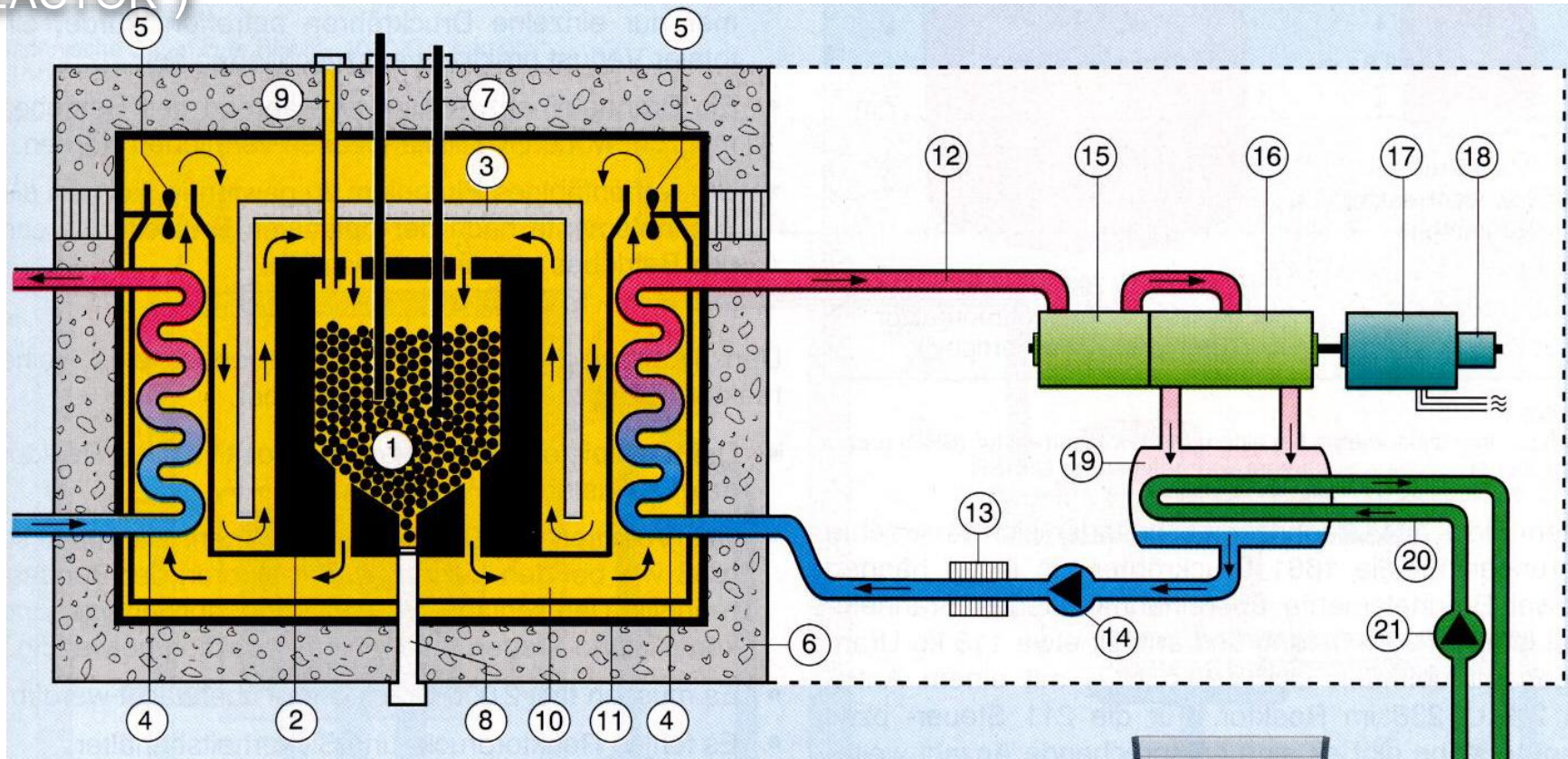

1 - pebble bed core, 2 - neutron reflector (graphite), 3 - iron shield, 4 - steam generator, 5 - cooling fan, 6 - pre-stressed concrete vessel, 7 - control rods, 8 - pebble extraction duct, 9 - pebble supply duct, 10 - cooling gas (He), 11 - sealing (steel), 12 - main steam, 13 - pre-heaters, 14 - feed water pump, 15 - high-pressure turbine, 16 - low-pressure turbine, 17 - generator, 18 - exciter machine, 19 - condenser, 20 - cooling water circuit, 21 - cooling water pump, 22 - dry cooling tower, 23 - air flow

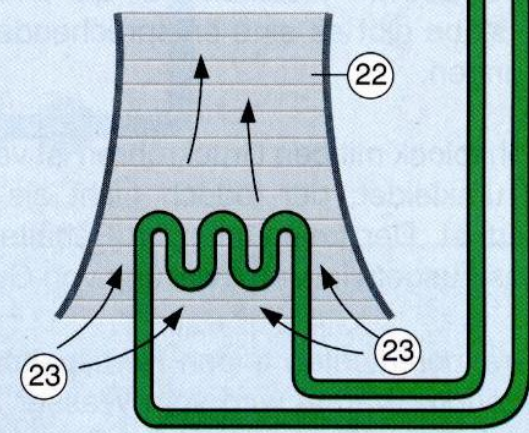

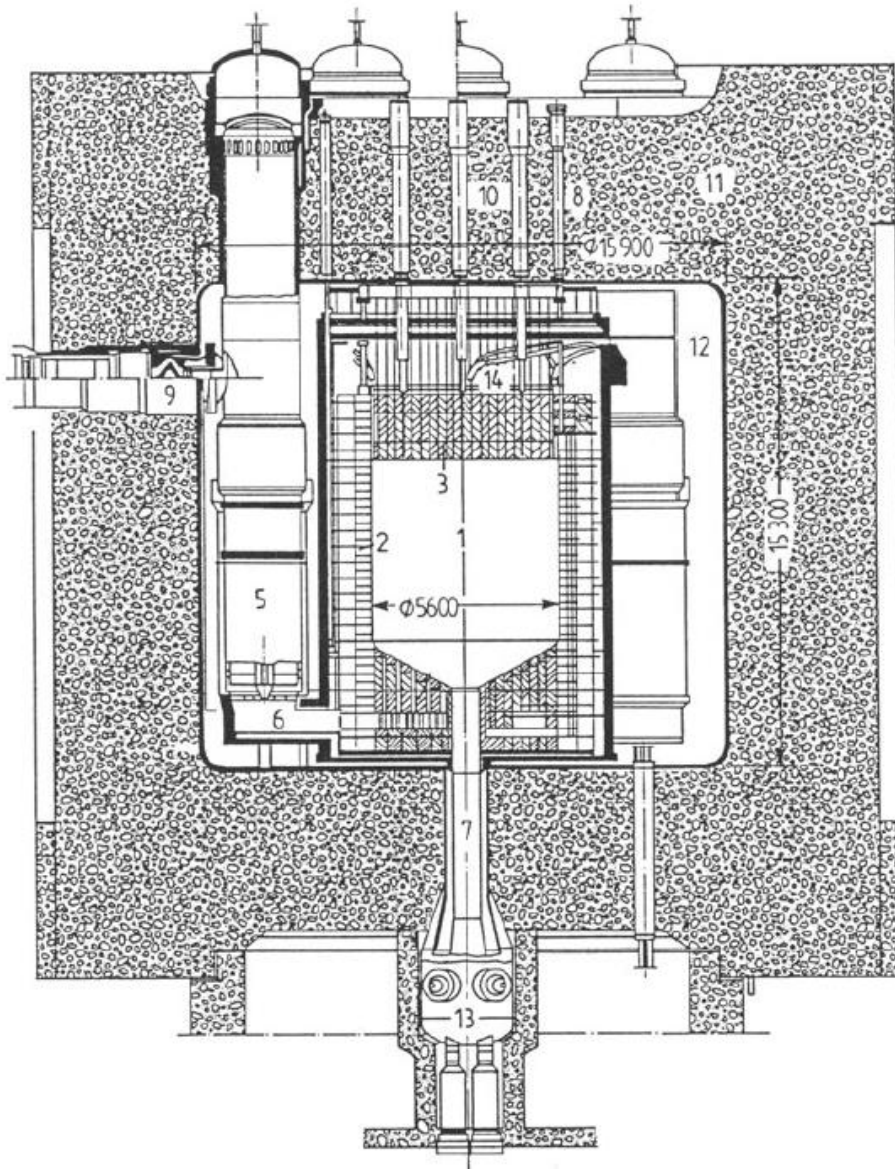

1. Core
2. Side reflector
3. Top reflector
4. Bottom reflector
5. Steam generator
6. Hot gas channel
7. Pebble extraction line
8. Control rods in the reflector
9. Helium circulator
10. Control rods pushed into the pebble bed
11. Pre-stressed concrete vessel
12. Liner with thermal insulation and cooling
13. Pebble extraction device
14. Pebble addition

Pebble distributor

Control rods

Pebble bed

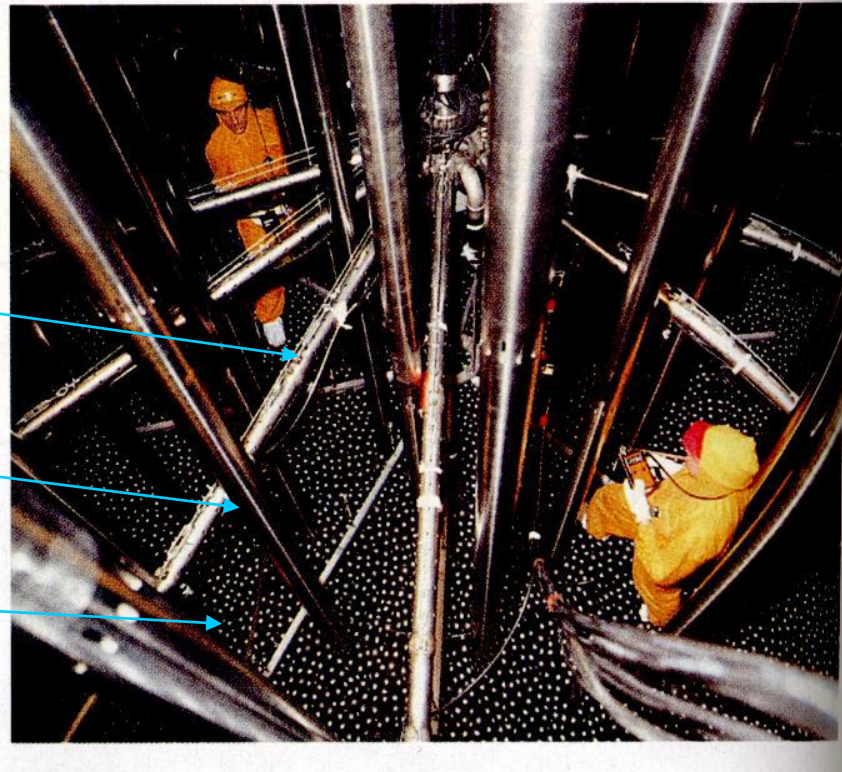

Refueling:

Permanent → no excess reactivity

Safety:

No excess reactivity + negative graphite temperature feedback + coated particles as "micro-containments" → inherent safety

Moderator:

Graphite / **But:** Moderator-fuel lattice is strongly under-moderated "epithermal spectrum" → higher enrichment necessary for criticality  
→ breeding feasible:

## Thorium-Uranium cycle

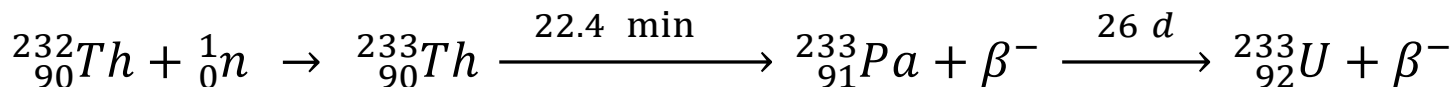

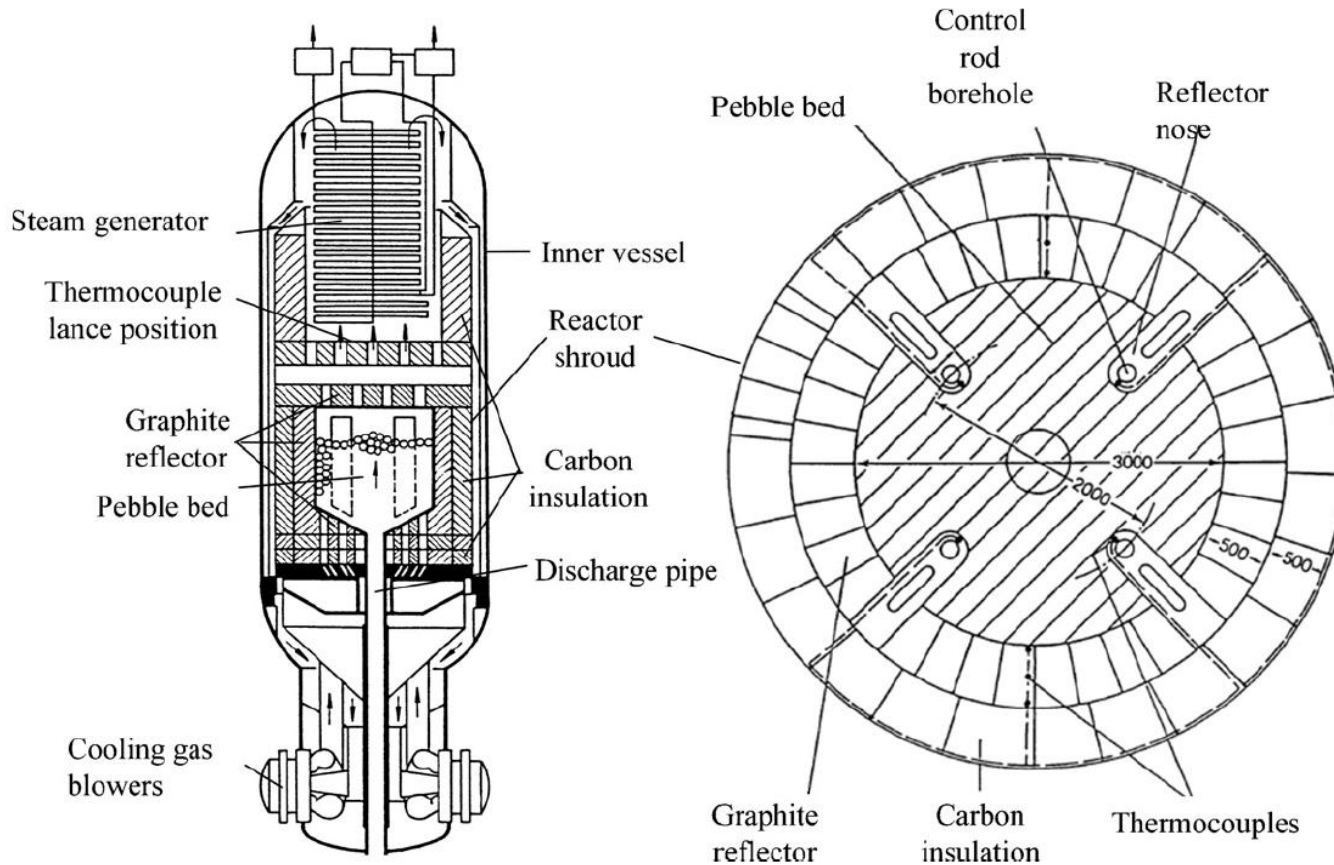

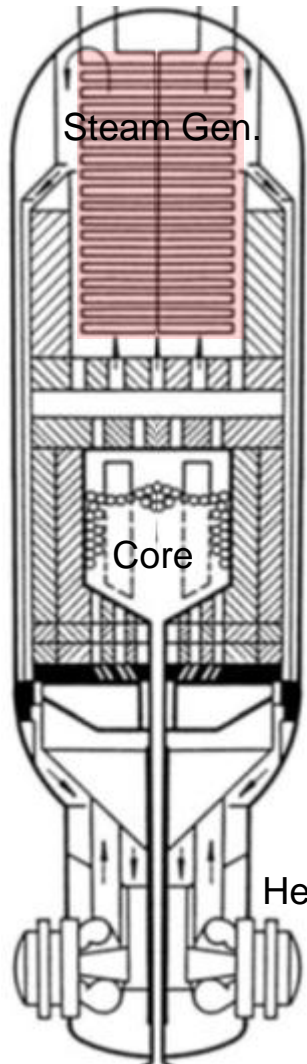

AVR (Jülich)

- Steam generator above core – eases water ingress in case of tube break

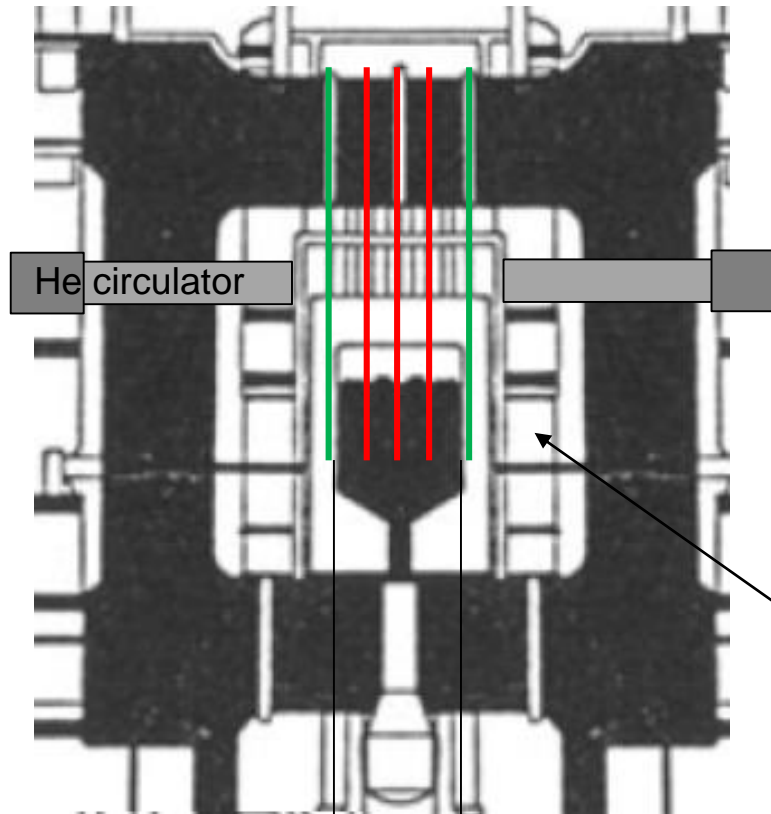

THTR (Hamm-Uentrop)

- Too large power → large core diameter → necessity of control rods for cold shutdown pushed into pebble bed without guide tubes → numerous broken pebbles
- Large core diameter → no inherently safe decay heat removal

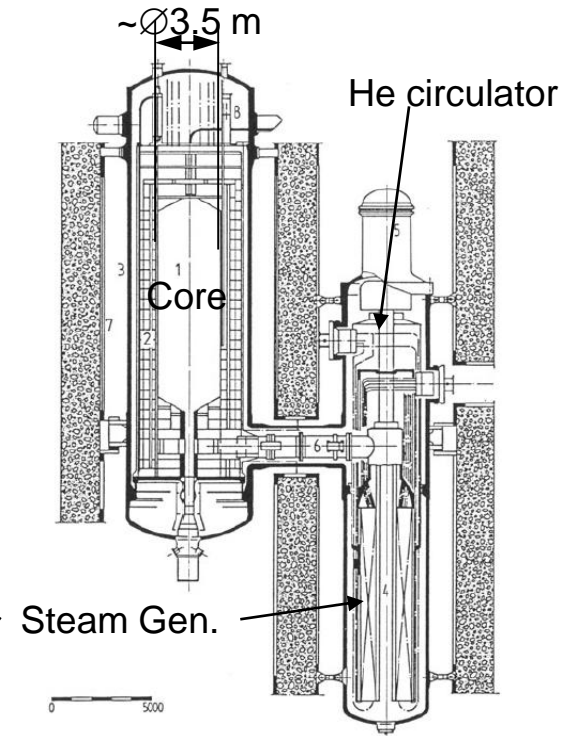

German modular HTR

- $Q_{th} \leq 250$  MW → Small enough diameter for control rods only in reflector (outside core)
- Small diameter → inherently safe decay heat removal via reactor pressure vessel wall
- Steam generator below reactor core → strong mitigation of water ingress by density difference He / H<sub>2</sub>O vapor

- Modular HTGR designs with coated particle fuel due to inherent safety against cooling failure

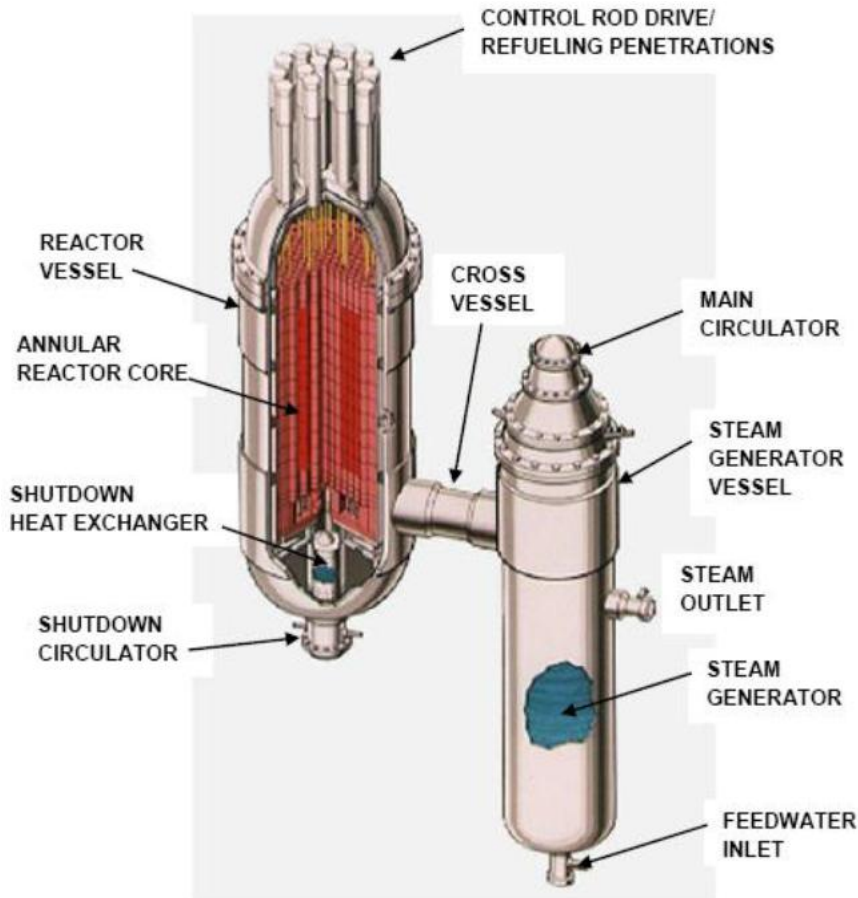

Modular HTGR with prismatic fuel

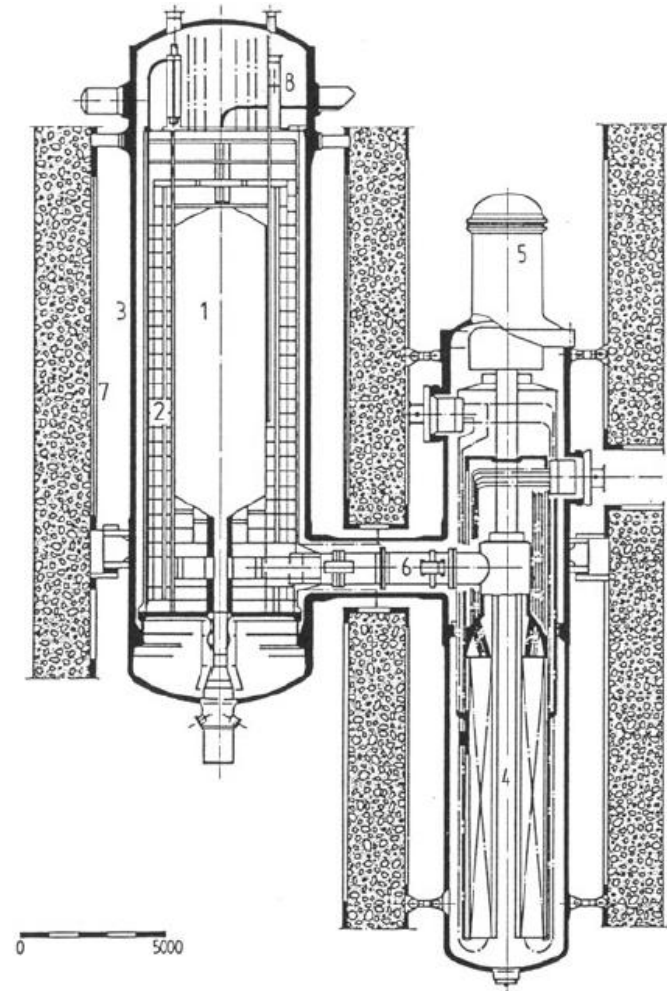

Modular pebble bed reactor

## High Temperature Reactor – Pebble Bed / Modular

- Twin unit under construction in China (Rongcheng, Province Shandong)
- Coolant: Helium (7 MPa, 250 → 750 °C)
- Steam turbine
- 2 x 250 MWt → 210 MWe

Improvements compared to early German prototypes:

- Improved pebble extraction
- Control rods in reflector
- Steam cycle (simple, less risk)
- Reduced outlet temperature of 750 °C

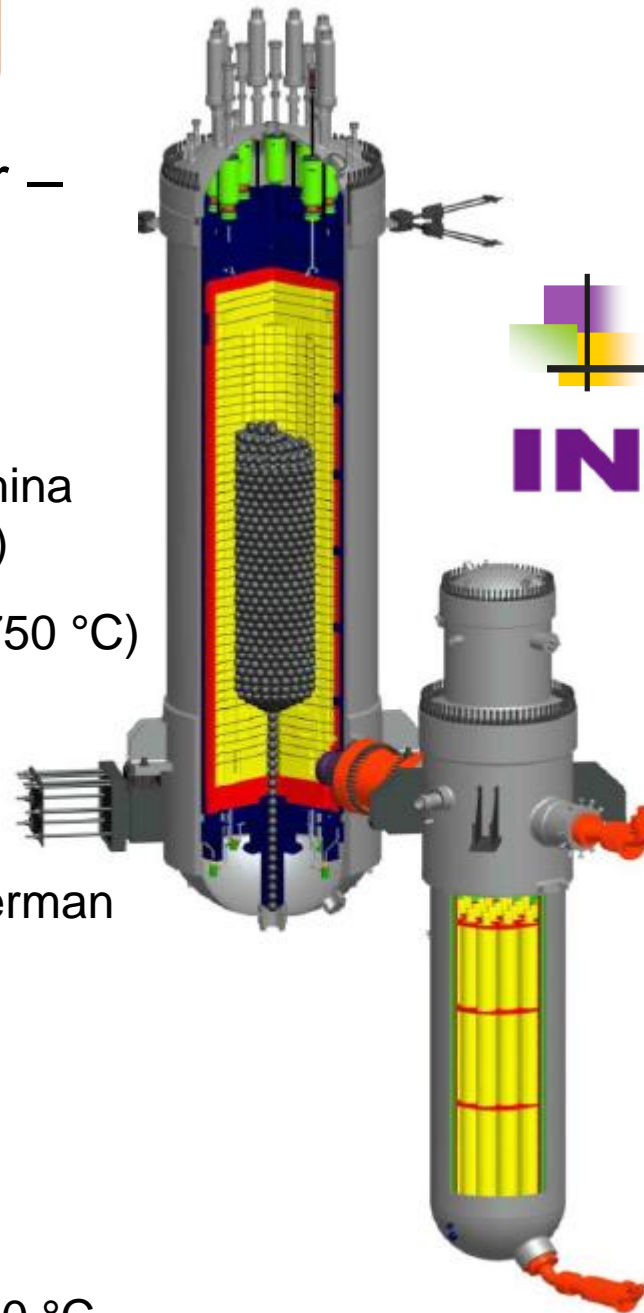

Main steam  
13.24 MPa, 566 °C

Efficiency: 42 %

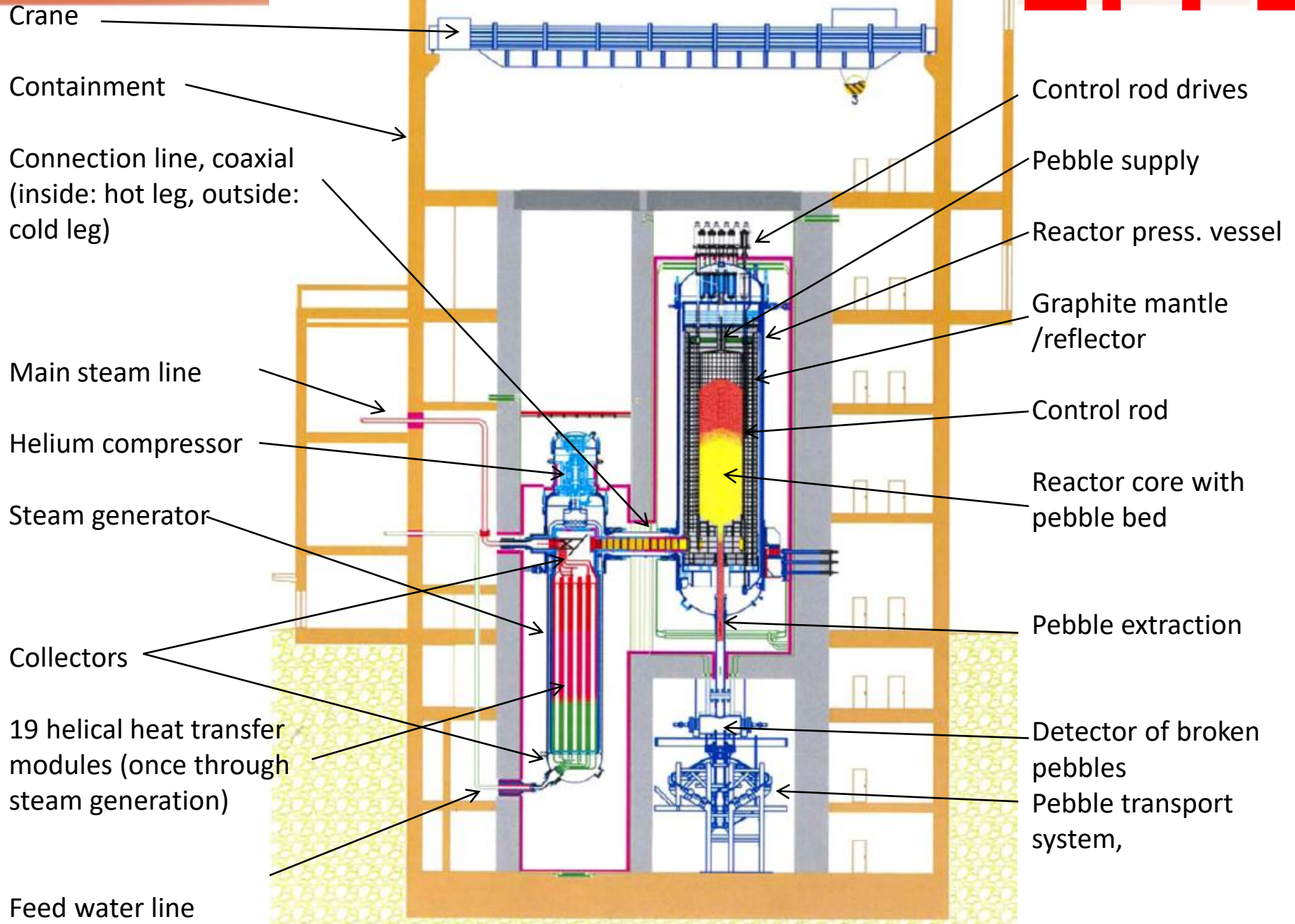

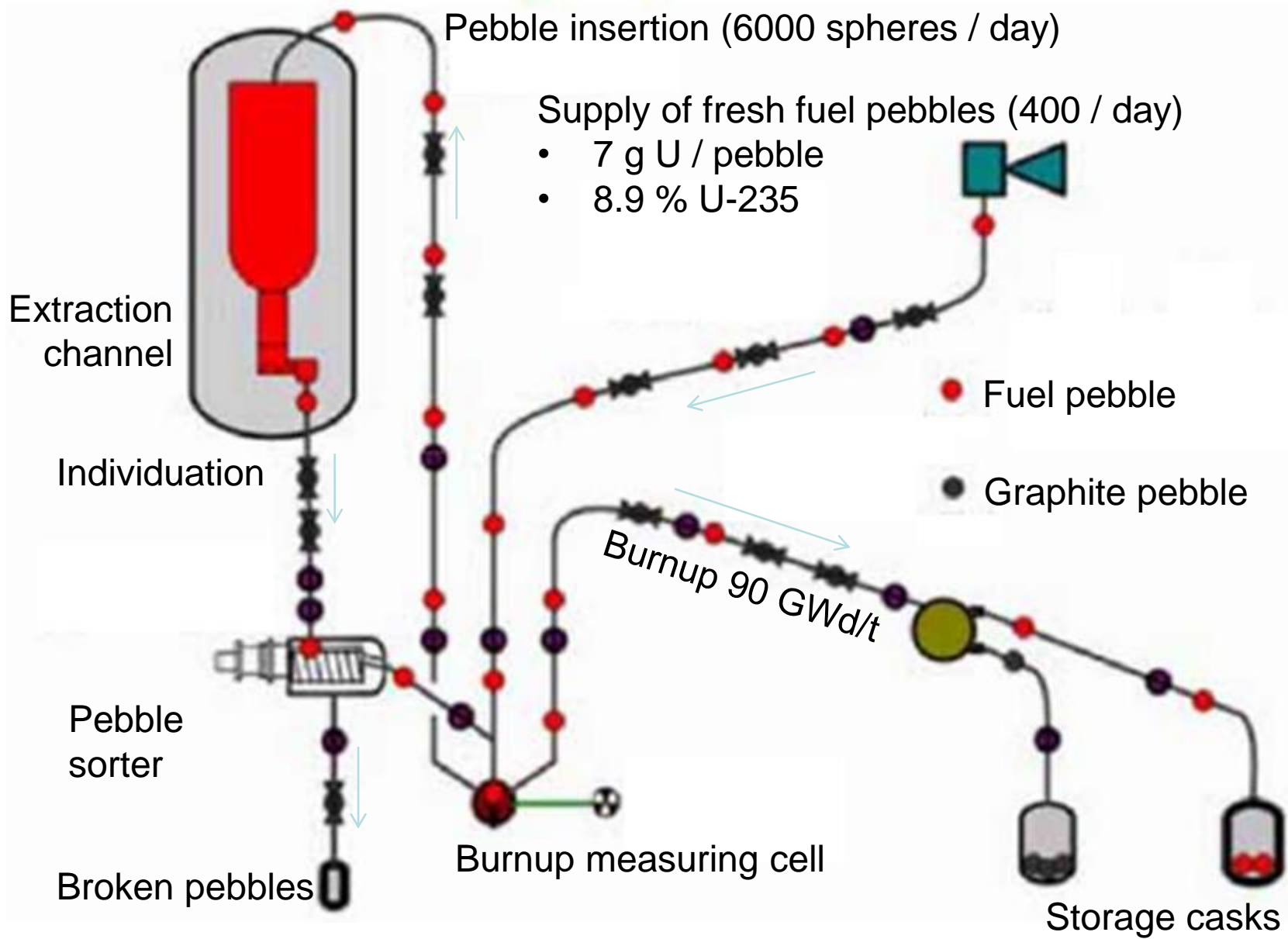

- Continuous refueling – no excess reactivity
- Thermal losses from the comparatively small and slim reactor can remove decay heat by natural convection and thermal radiation at below 1600 °C
- Strong negative feedback from fuel and moderator temperature to reactivity
- Temperature increase in case of cooling failure makes reactor subcritical while temperature stays below 1600 °C
- SiC layers stay effective as barrier against fission product release
- HTR-PM = inherently safe design regarding a full unprotected loss of cooling

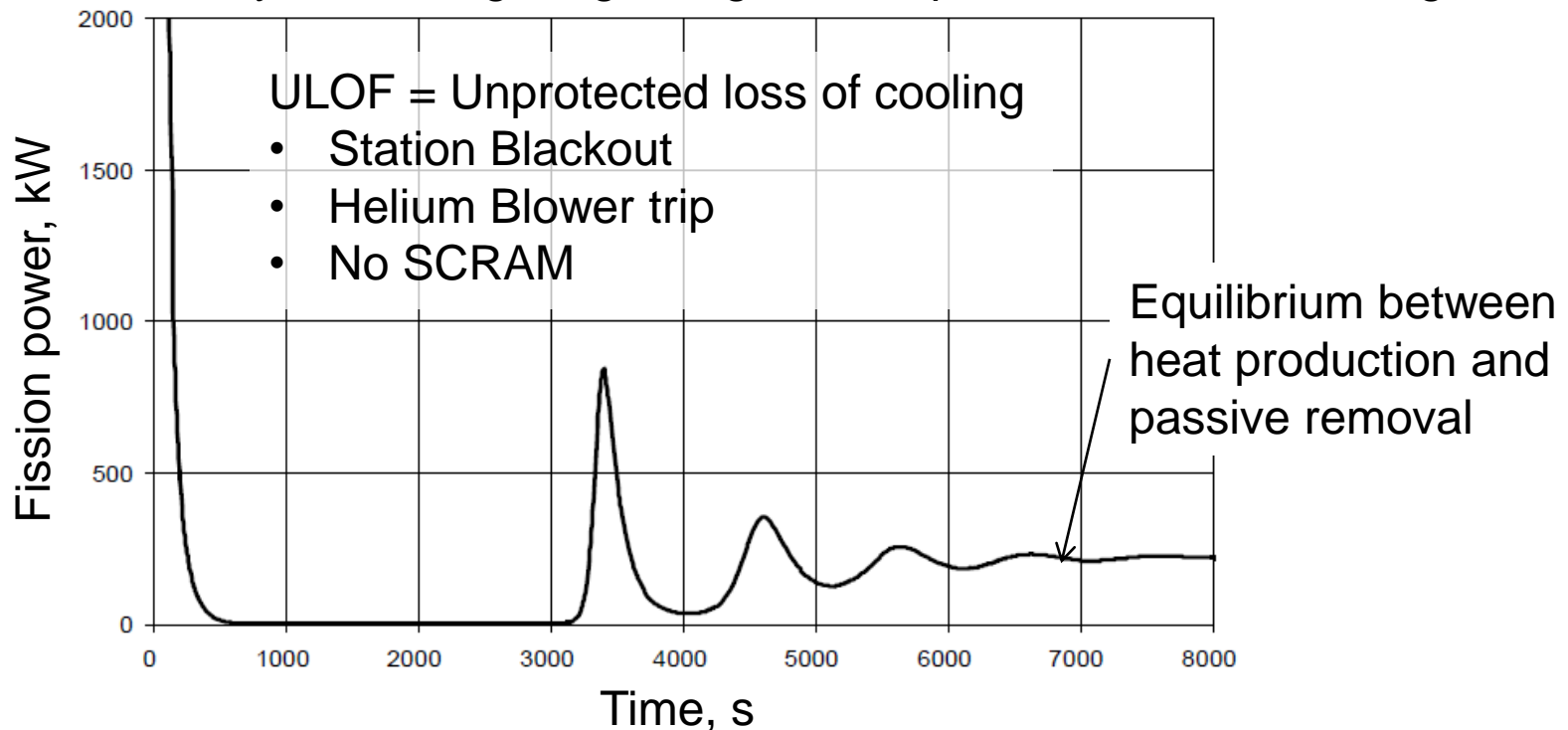

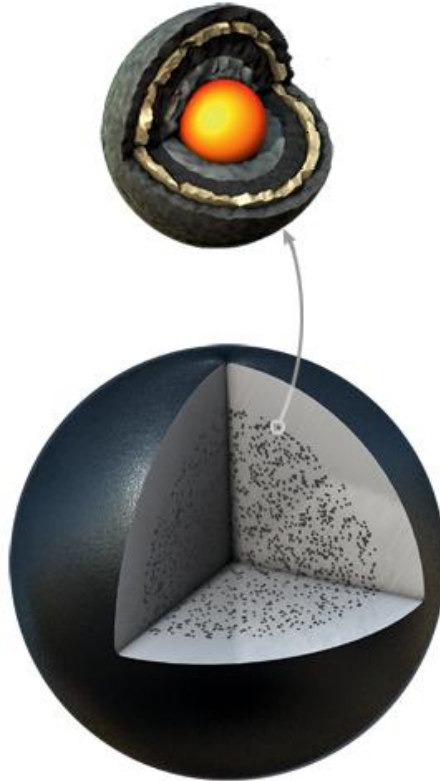
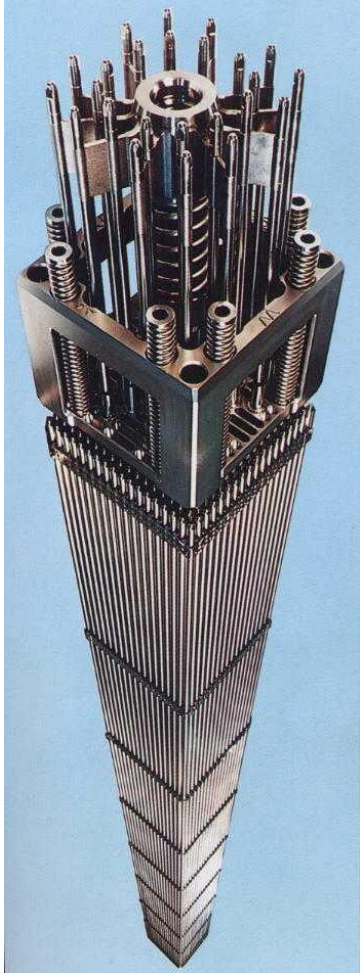

## HTR-PM

Inventory:	420'000 Pebbles
Usage per year:	145'000 Pebbles
Uranium content:	7 g/pebble
Pebble diameter:	6 cm
Average density:	0.0458 g U/cm <sup>3</sup>

## PWR

Inventory:	~200 fuel elements
Usage per year:	~40 fuel elements
Average density:	~3 g U/cm <sup>3</sup>

**Waste ratio: 65!**

- Main technological aspects associated with
  - Gas cooled reactors
  - High Temperature Gas Cooled Reactors