

Broad topic	Lecture title
Basic principles of NPP	Introduction / Review of nuclear physics
	Interaction of neutrons with matter
	Nuclear fission
	Fundamentals of nuclear reactors
	LWR plants
Modeling the beast	The diffusion of neutrons - Part 1
	The diffusion of neutrons - Part 2
	Neutron moderation without absorption
	Neutron moderation with absorption
	Multigroup theory
	Element of lattice physics
	Neutron kinetics
	Depletion
Reactor Concepts Zoo	Advanced LWR technology
	Breeding and LFR
	AGR, HTGR
	Channels, MSR and thorium fuel
Review session	

- Light Water Reactors general aspects
- Material selections
- Details about the Pressurized Water Reactor
- Details about the Boiling Water Reactor

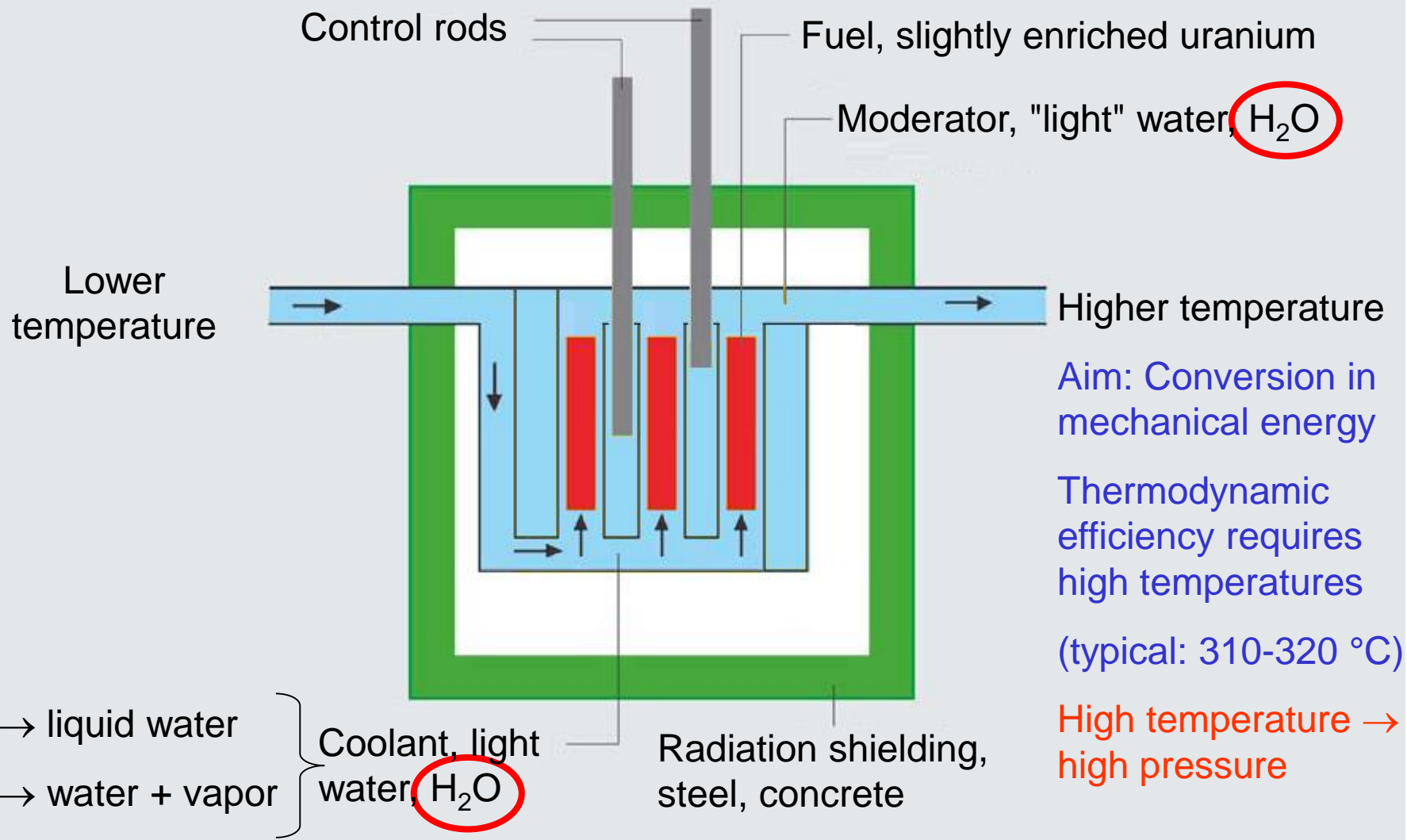

- **Thermal reactors, fission mainly by thermal neutrons**
 - Coolant = moderator = light water (H_2O)
 - Typical enrichment of fresh fuel: 3.6 % - 5.0 % U-235
 - Fuel composition:
 - ✓ UO_2 in form of sintered ceramics (pellets), density $\sim 10 \text{ g/cm}^3$
 - Fuel cladding: zirconium alloys
 - ✓ (good compromise between low neutron absorption and corrosion stability)
- **Leading types (with reactor pressure vessel (RPV)):**
 - Pressurized Water Reactor (two circuits)
 - Boiling Water Reactor (one circuit)
- **Exotic (and dangerous) species:**
 - Graphite moderated pressure-pipe reactors (RBMK = Chernobyl)



Views of fuel rods and UO₂ pellets



Typical dimensions

- Height: 2.5 - 4 m
- Diameter: ca. 10 mm
- Cladding: ca. 0.7 mm

Fuel material: UO₂ with 3 - 5 % U-235
Cladding material: Zirconium alloys

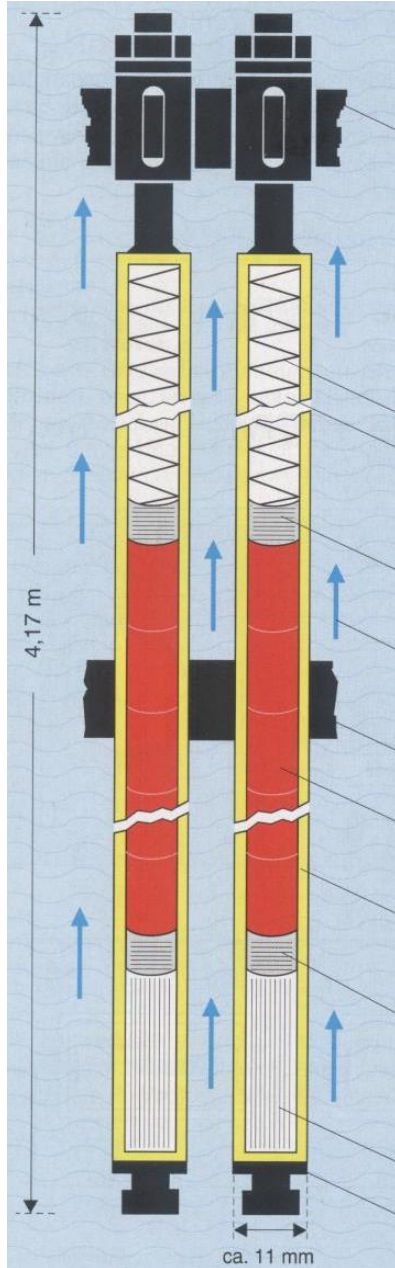

Support plate

Spring
Space for fission gases

Inert pellet (Al₂O₃)

Coolant flow

Spacer

Fuel pellet (UO₂)

Gas-tight cladding

Inert pellet (Al₂O₃)

Support tube

Foot piece

UO₂ powder is pressed to **Pellets** and sintered

- Addition of binding agents (e.g. Stearine) to the powder
- Pressing of so-called "green bodies" (Grünlinge)
- Evaporation of the binding agent at about 900 ° C
- Sintering / burning at about 1600 - 1700 ° C in H₂ atmosphere

Advantages compared to metallic uranium

- UO₂ is inert in air, inactive in water
- High melting point: 2760 - 2880 ° C, Boiling point: 3200 ° C
- High volumetric stability
- Fission gas can escape through residual porosity – lower tendency to swelling
- *Disadvantage:* Lower thermal conductance (approximately by a factor of 3)

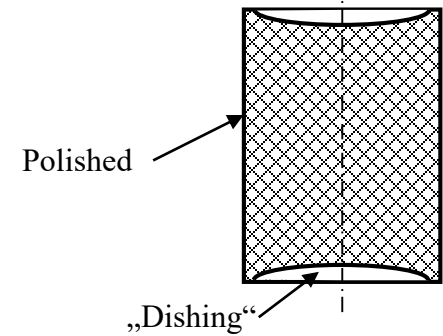

- Compensation of thermal dilatation
- Reservoir for fission gases



UO₂ Pellets

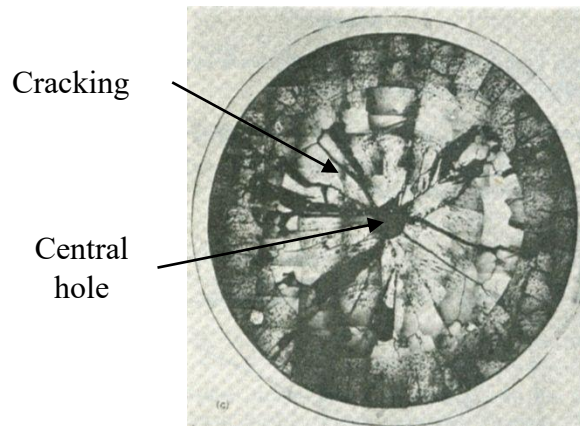

Pellet with thermal cracking

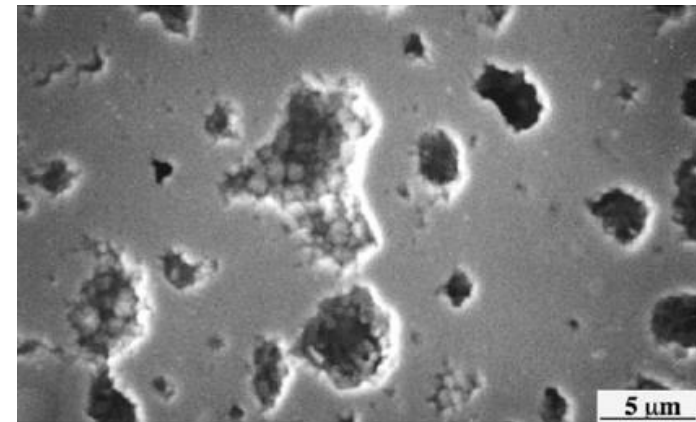

Fission gas pores in irradiated UO₂

- Today: Burn-up 50 - 60 GWd_{th}/t → Preferred fuel for Light Water Reactors (PWR, BWR)

Element	σ_a , barn	Application
Mg	0.063	unstable in water → gas cooled, graphite moderated reactors
Al	0.231	unstable in water above 100 °C → used in research reactors
Ti	6.09	} Composition of stainless steel / Austenite (z.B. X6CrNiTi1810)
Cr	3.05	
Fe	2.56	
Ni	4.49	
Co	37.18	${}_{27}^{59}\text{Co} + {}_0^1\text{n} \rightarrow {}_{27}^{60}\text{Co}^* + \gamma$ $T_{1/2} = 5.27 \text{ a}$, $E_\gamma = 1.33, 1.17 \text{ MeV}$, avoid Co!
Zr	0.185	optimal material for Light Water Reactors (PWR, BWR)



Low neutron absorption + good corrosion stability

Zirconium is applied in form of alloys:

	Additions in mass-%			
	Sn	Fe	Cr	Ni
Zircaloy-2	1,5	0,15	0,1	0,05
Zircaloy-4	1,5	0,12-0,24	0,1	0,007

- Good corrosion stability in water due to stable oxide layer formation
- Protective oxide layer becomes unstable above $\sim 450^\circ \text{C}$ → Cladding surface temperature limit in Light Water Reactors → average coolant temperature limit at reactor outlet $\sim 350^\circ \text{C}$

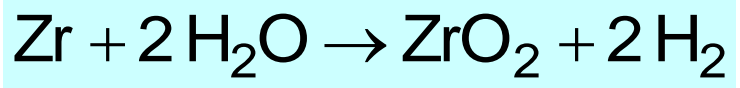

Negative effects:

- Cladding destruction
- Hydrogen production
- Exothermal
- At high rates self-sustaining

Oxide layer thickness D according to Borgwald & Gulden, 1982:

$$D \frac{dD}{dt} = A \cdot e^{-\frac{B}{T}}$$

$A = 1.55 \cdot 10^{-5} \text{ m}^2/\text{s}$, $B = 20070 \text{ K}$

Solution for $T = \text{const}$:

$$\delta = \frac{100 \%}{D_0} \sqrt{2 \cdot t \cdot A \cdot e^{-\frac{B}{T}}}$$

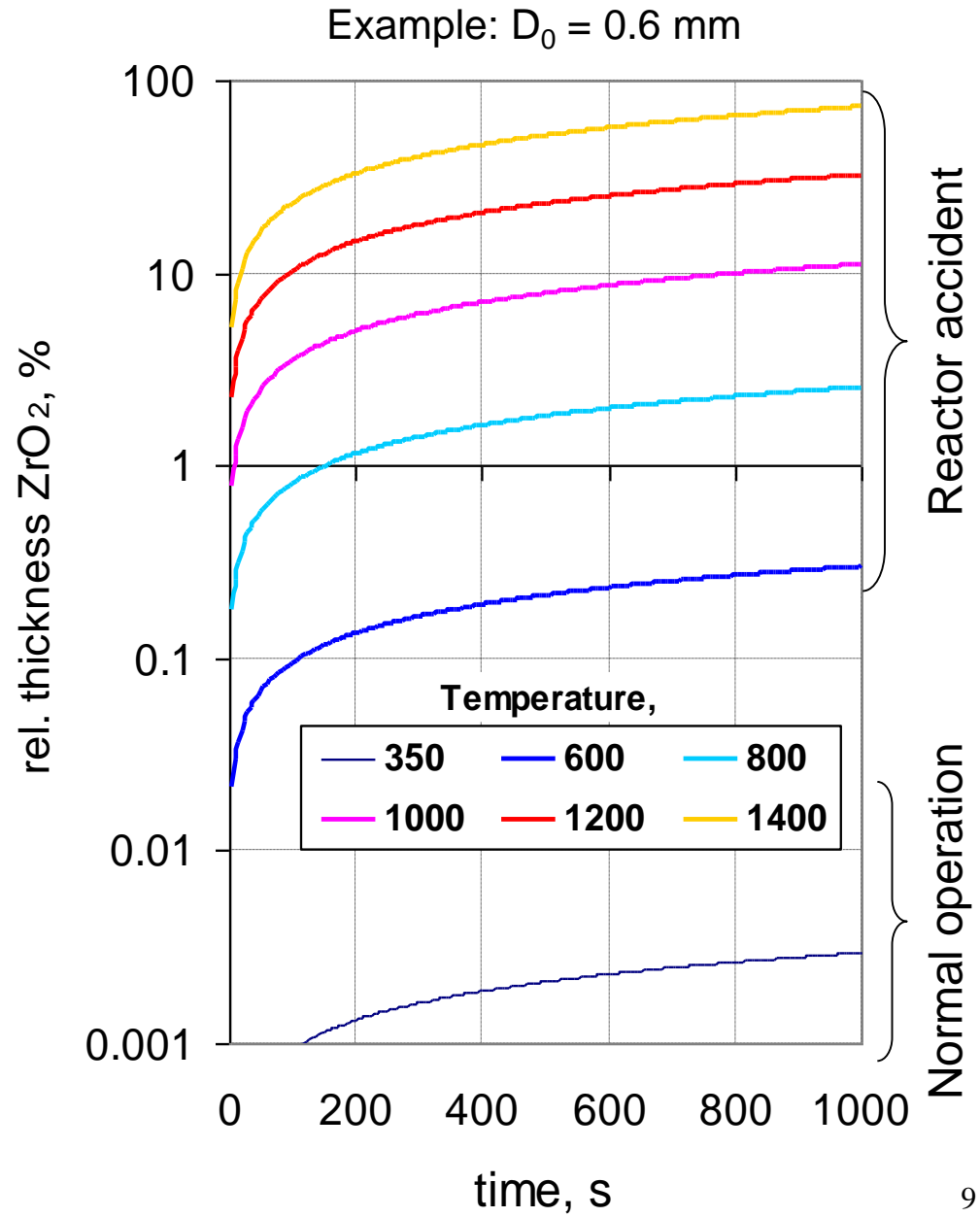

Fuel rod cladding: First and most important barrier against release of radioactive products from the nuclear reactions

Avoid cladding damage (oxidation, thermal damage, fuel-cladding interaction)

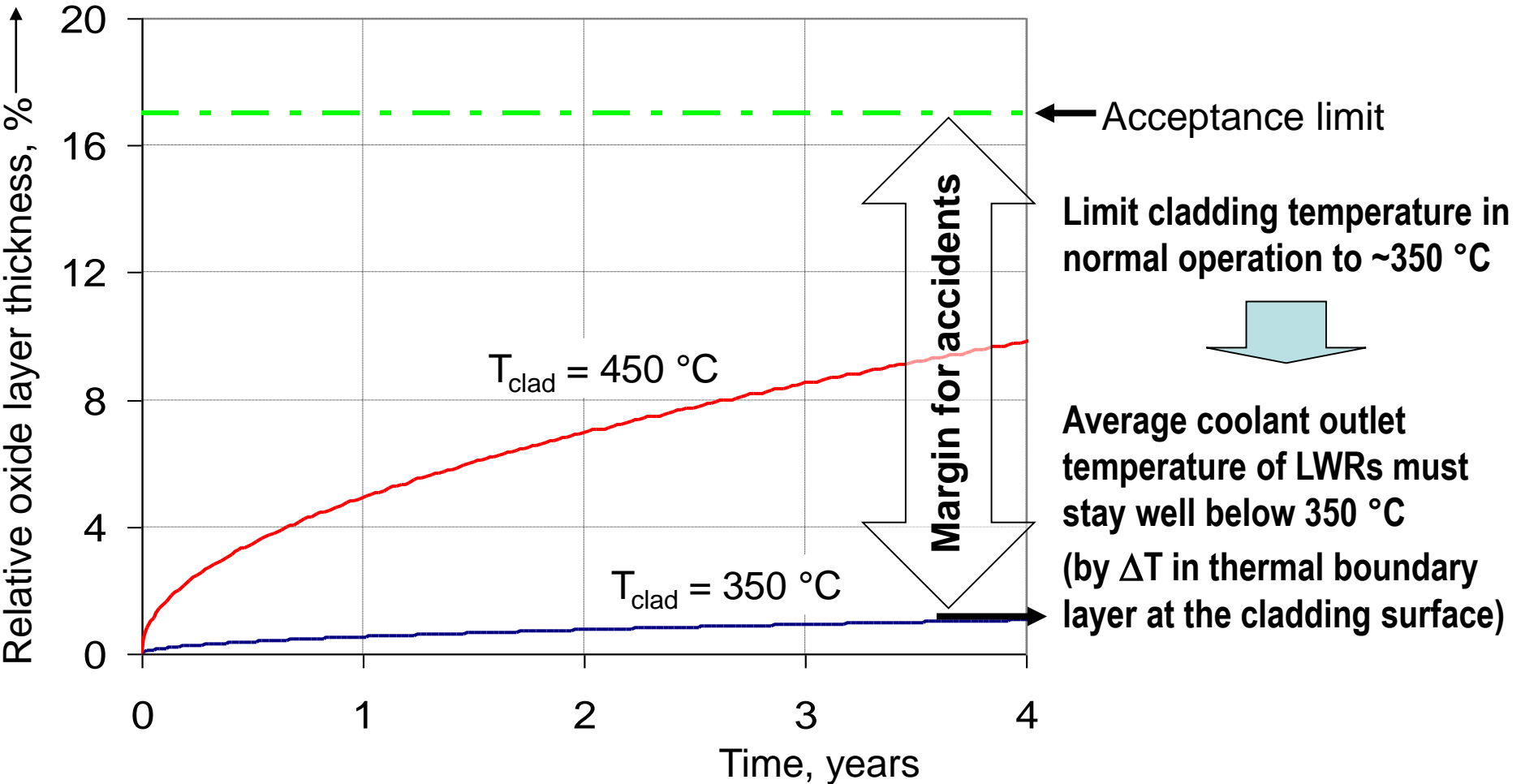

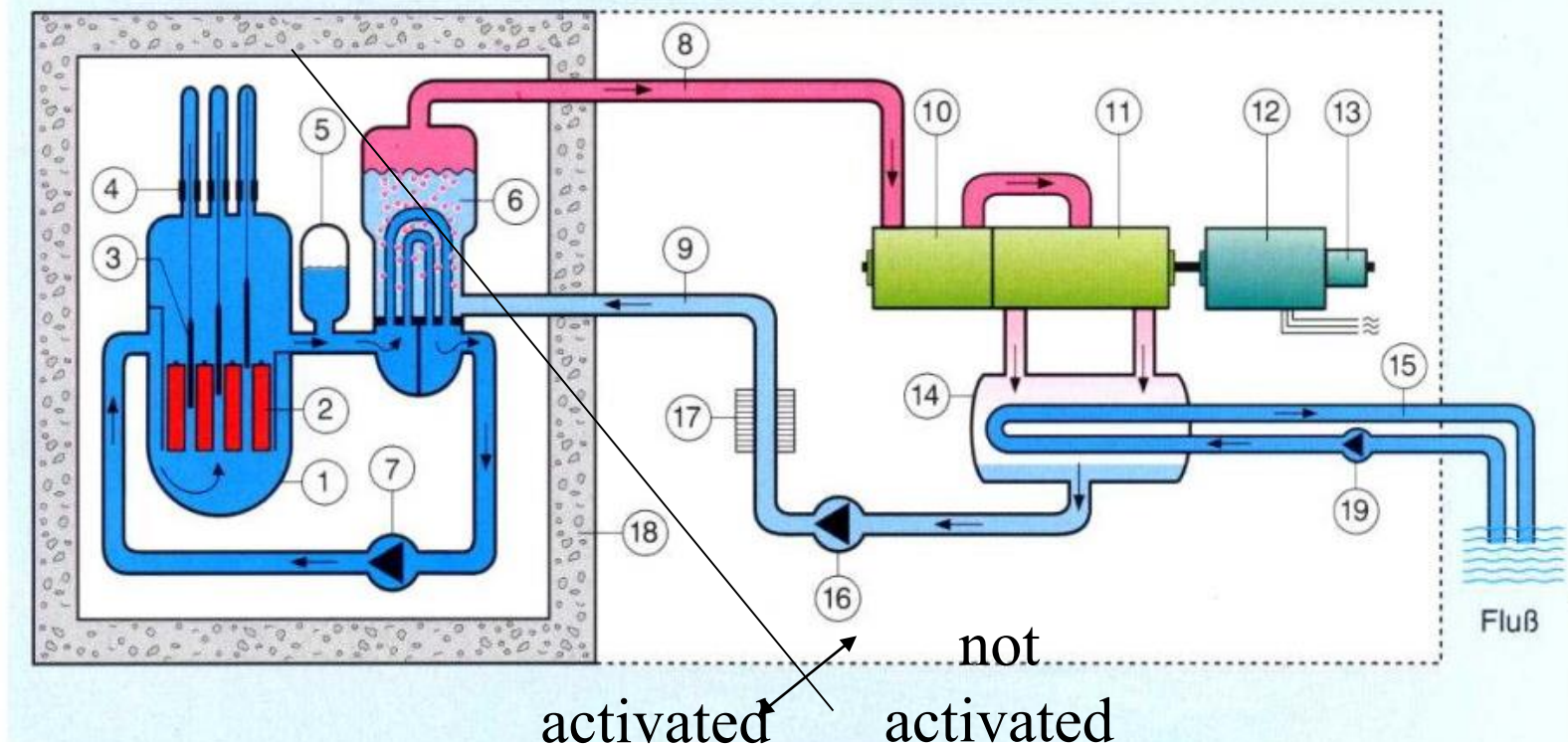

- 1 - Reactor Pressure Vessel, 2 - Fuel Elements, 3 - Control Rods, 4 - Control rod drives,
- 5 - Pressurizer, 6 - Steam Generator, 7 - Main Coolant Pump, 8 - Main Steam Line,
- 9 - Feed water line, 10 - High Pressure Stage of the Turbine, 11 - Low Pressure Stage,
- 12 - Generator, 13 - Exciter, 14 - Condenser, 15 - River Cooling, 16 - Feed water Pump,
- 17 - Regenerative Pre-Heater Stages, 18 - Concrete Shielding, 19 - Cooling Water Pump

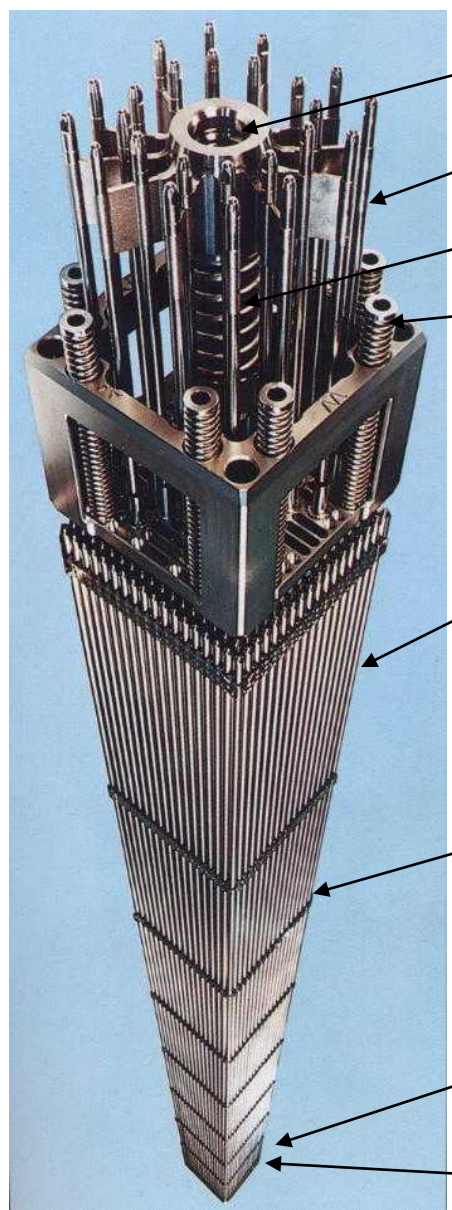

Coupling for control rod drive

Control rods - cluster control rods (run in guide tubes)

Damper for control rod drop

Head part with suppression springs

Fuel rods

- Typical fuel rod grid dimensions: 17 x17
- Number of fuel rods: 265
- Number of control rods: 24

Distance grid

fix fuel rod position in horizontal plane
improve heat exchange

Debris filter

Foot

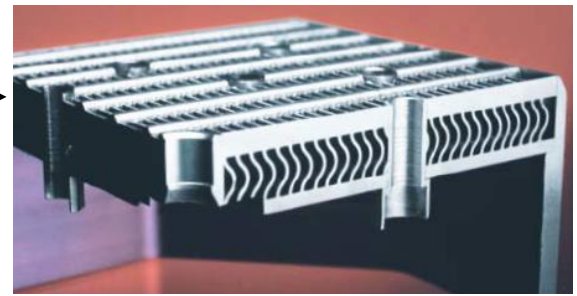

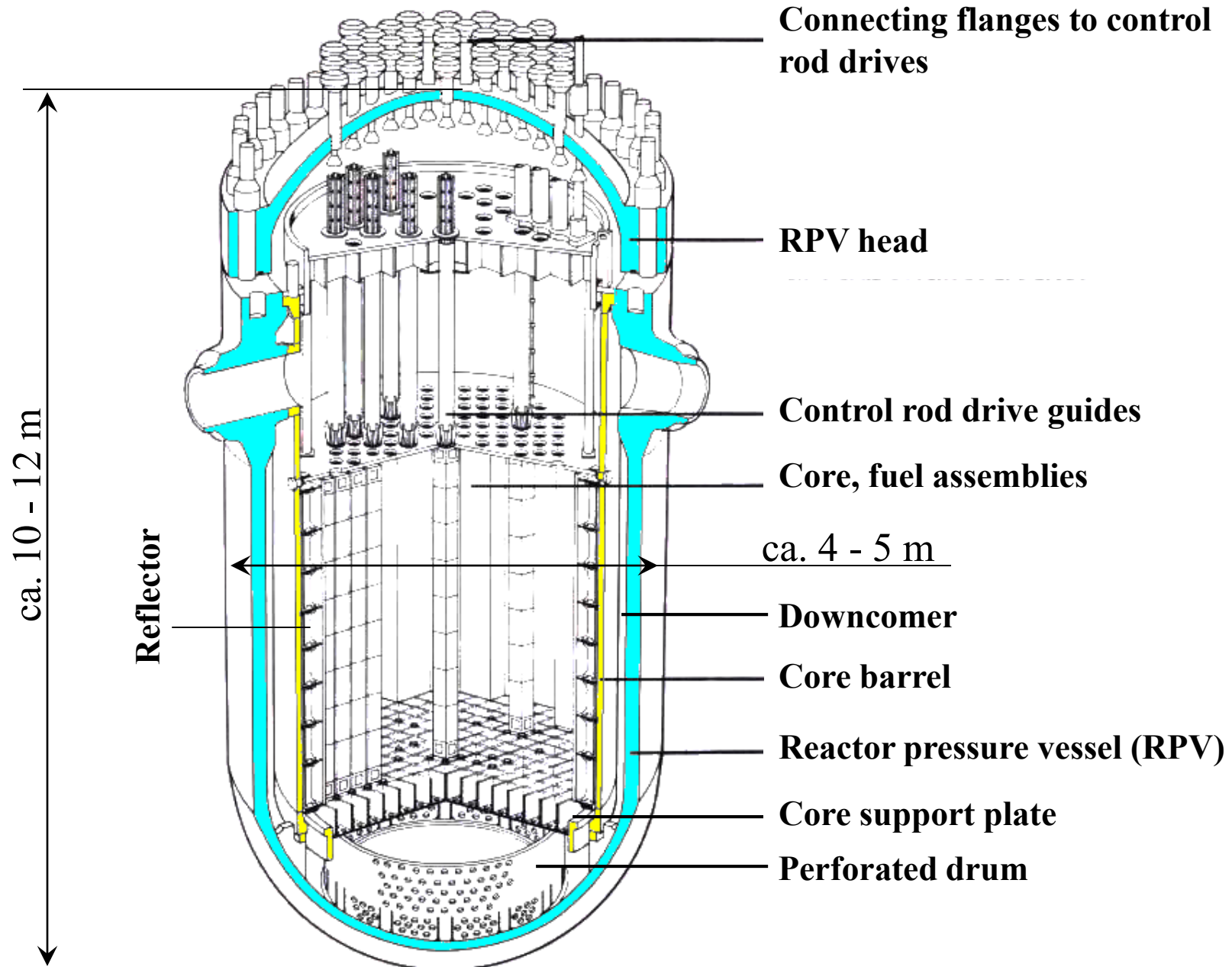

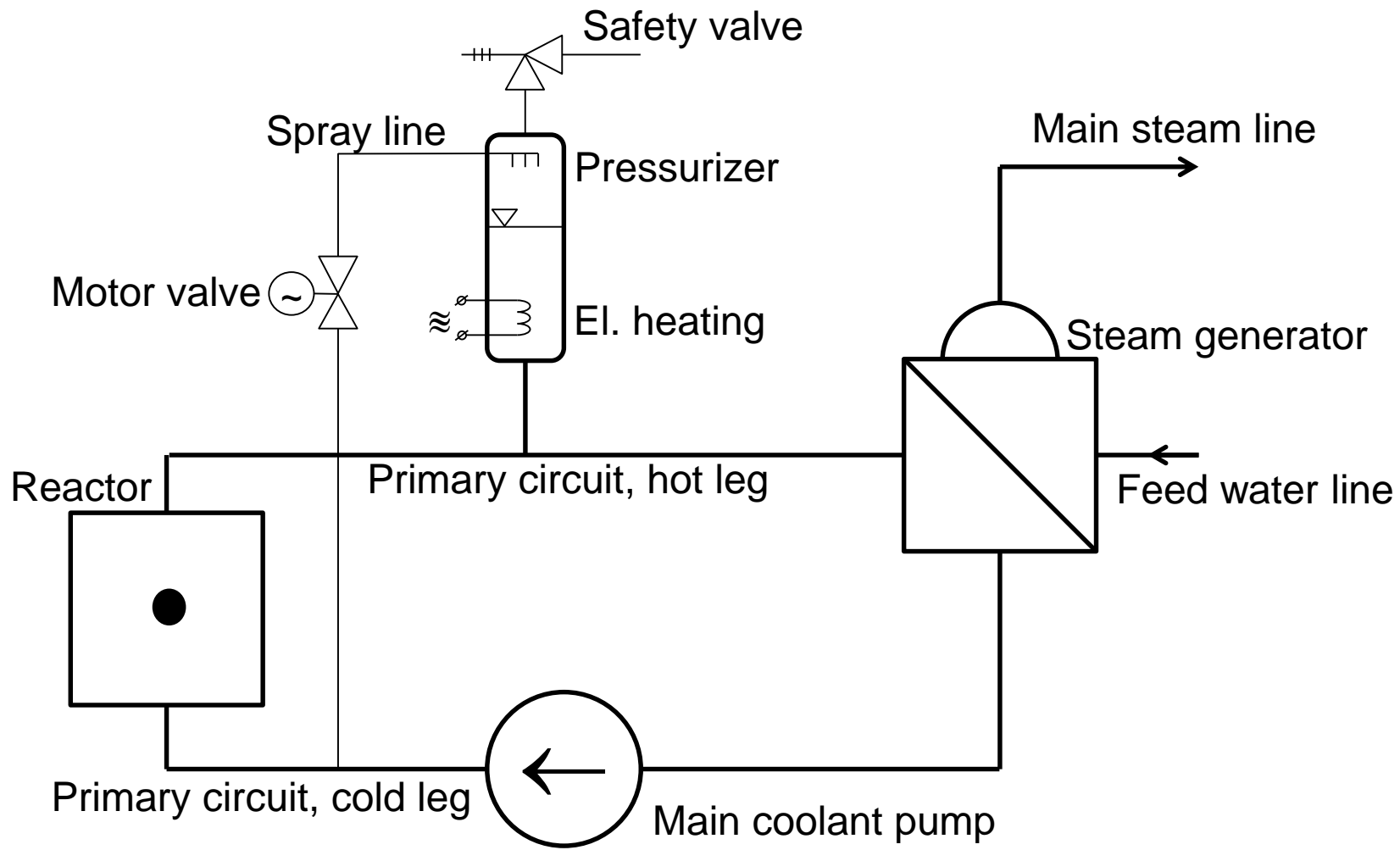

Example: $Q_{th} = 4000 \text{ MW}$

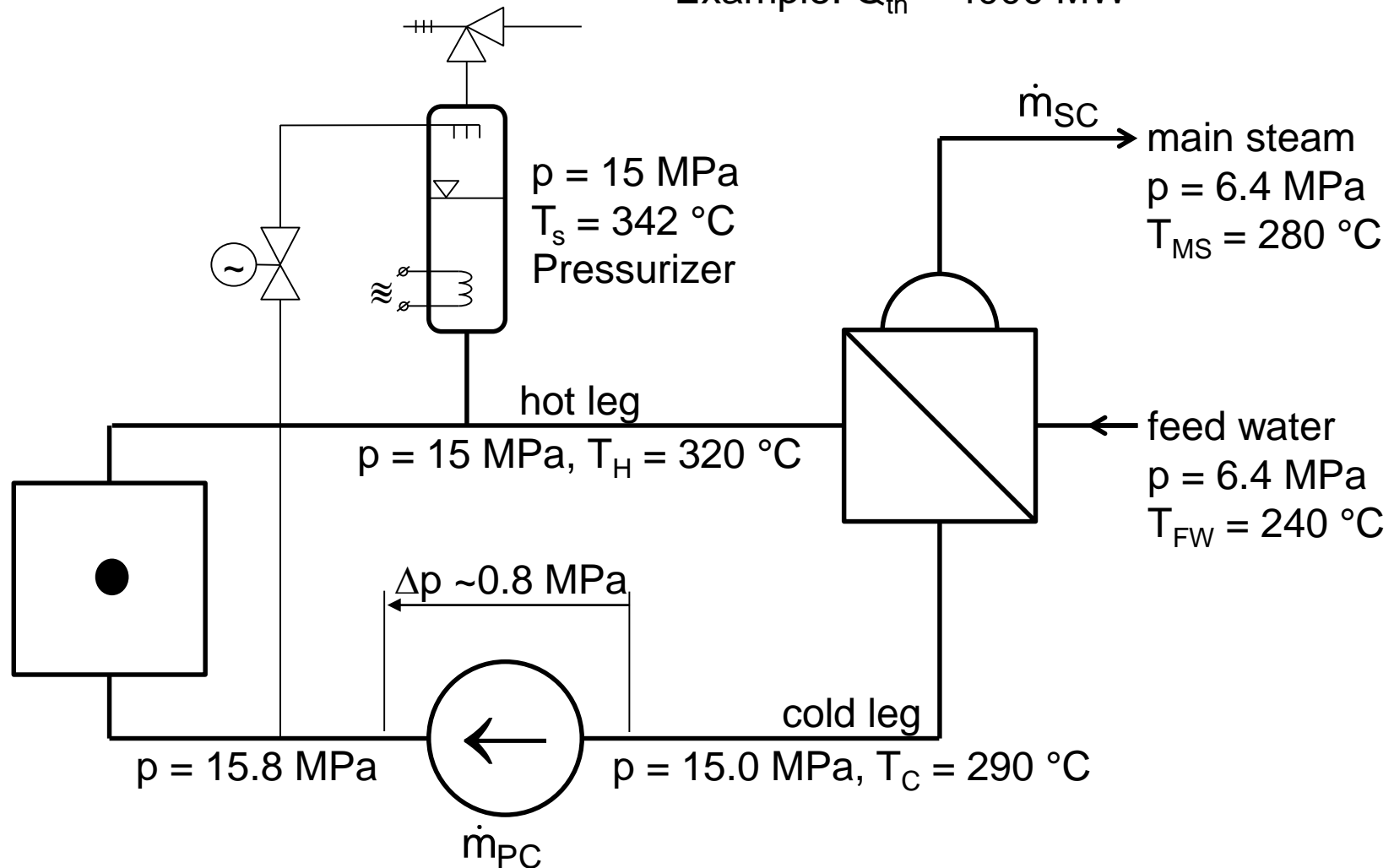

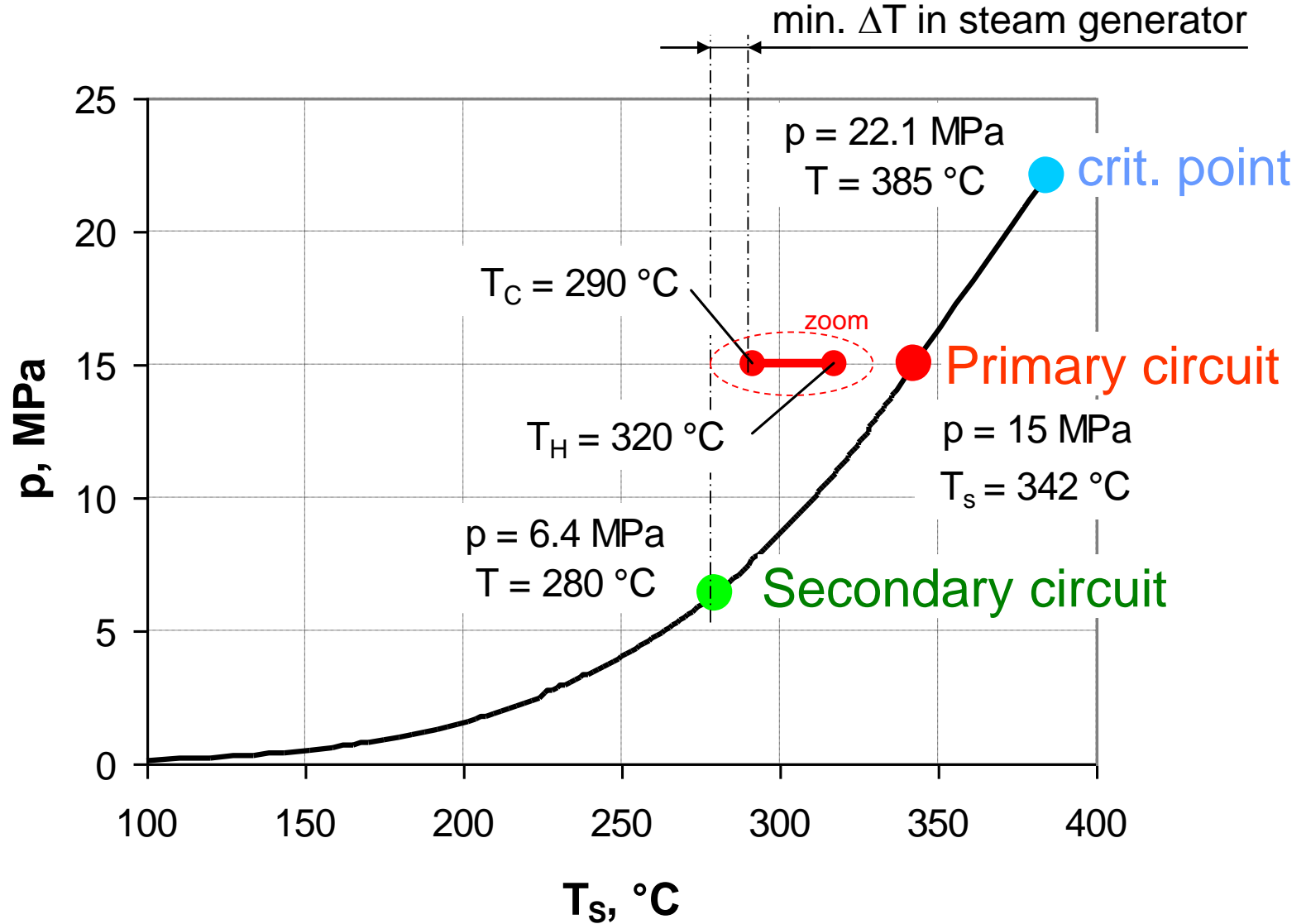

p-T diagram of water

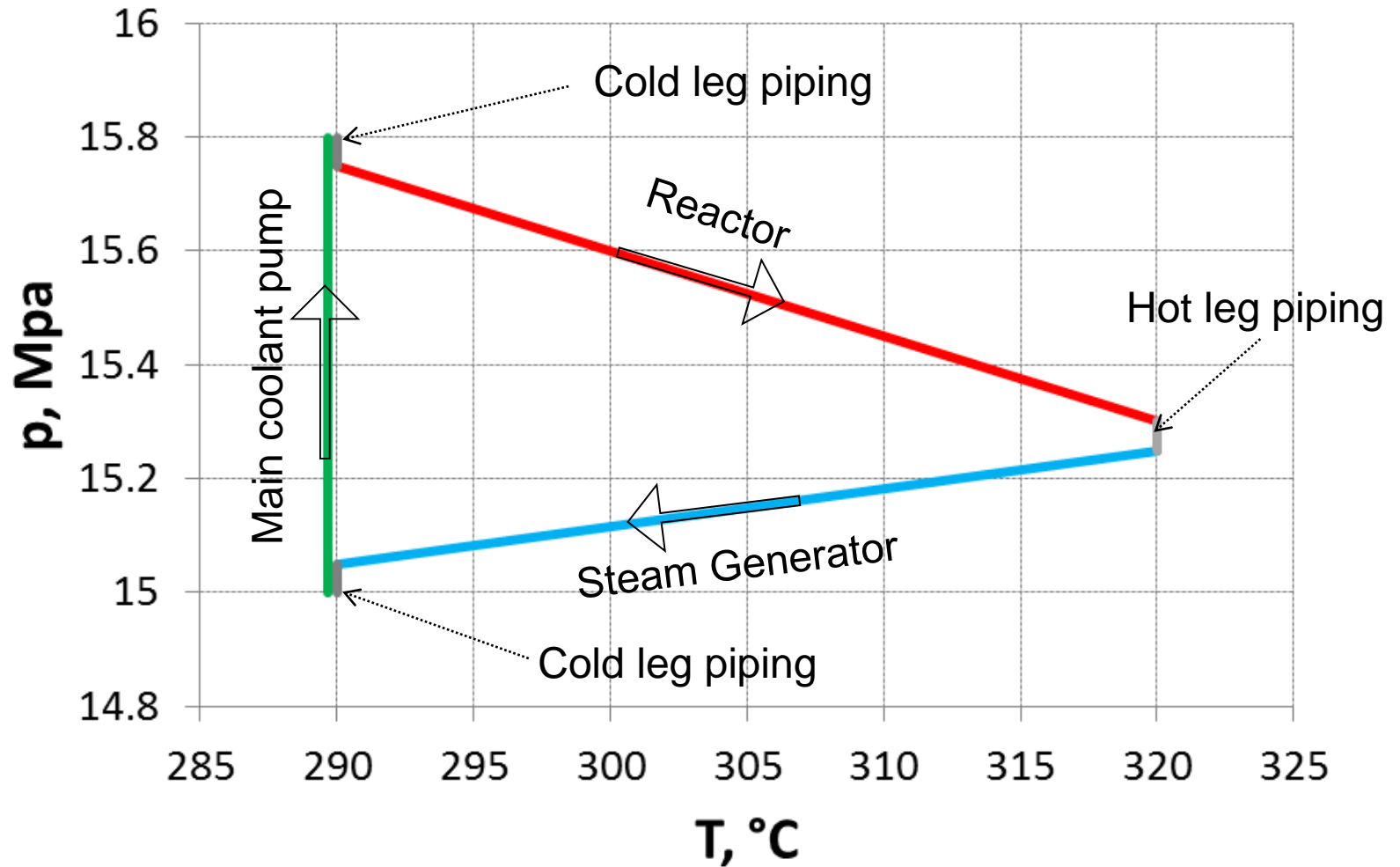

Main circulation pump has to compensate pressure losses in primary circuit

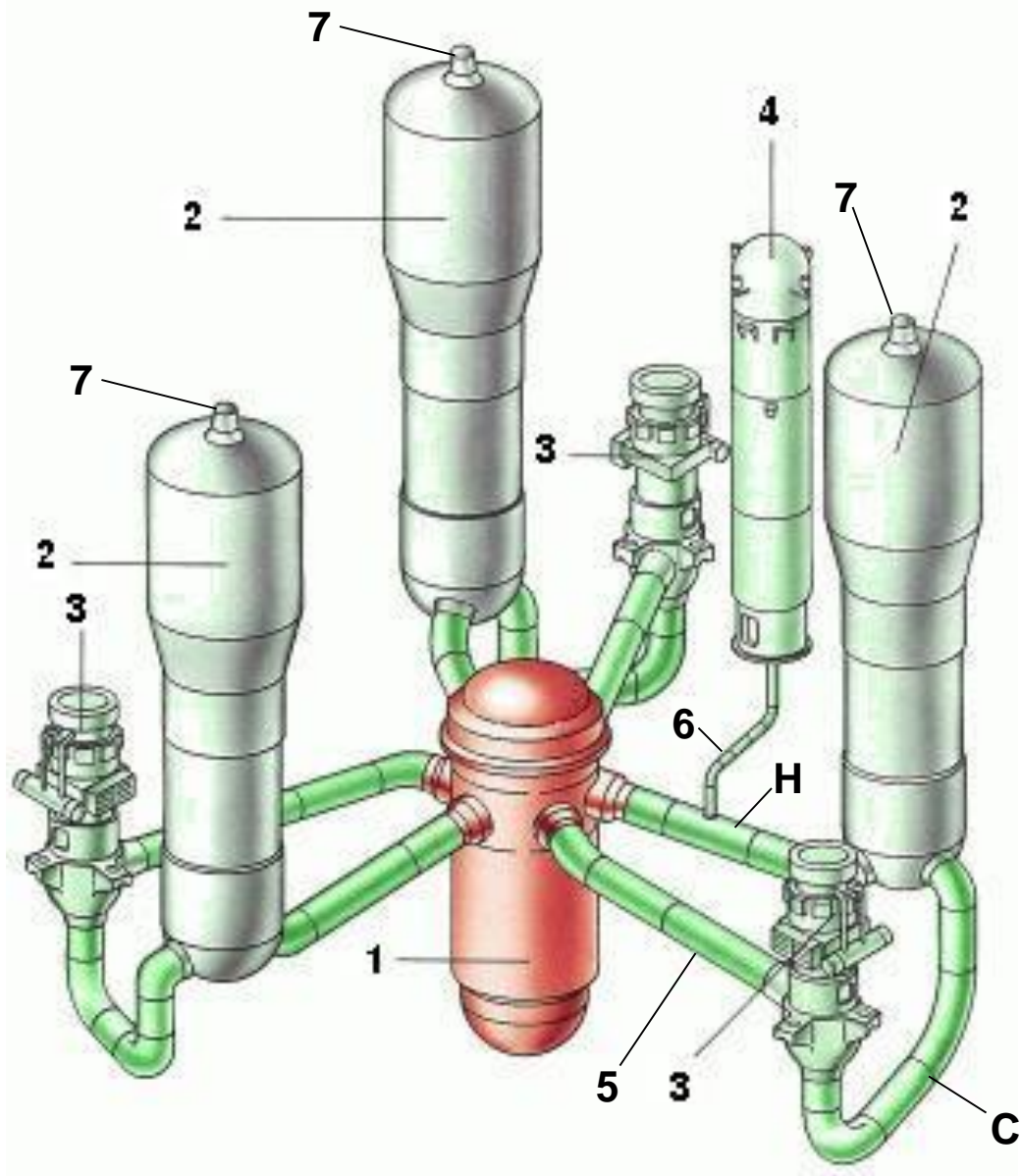

More than 1 loop needed to remove the thermal power

- 1 – Reactor
- 2 – Steam generator
- 3 – Main coolant pump
- 4 – Pressurizer
- 5 – Main coolant lines
- 6 – Pressurizer surge line
- 7 – Main steam nozzle
- H – Hot leg
- C – Cold leg

Example: Three-loop design (e.g. NPP Gösgen)

[Interactive PWR representation](#)

1 - High Pressure Stage of the Turbine, 2 - Low Pressure Stage, 3 - Condenser, 4 - Generator
 5 - Separator-reheater, 6 - Feed water tank, 7 - cooling water

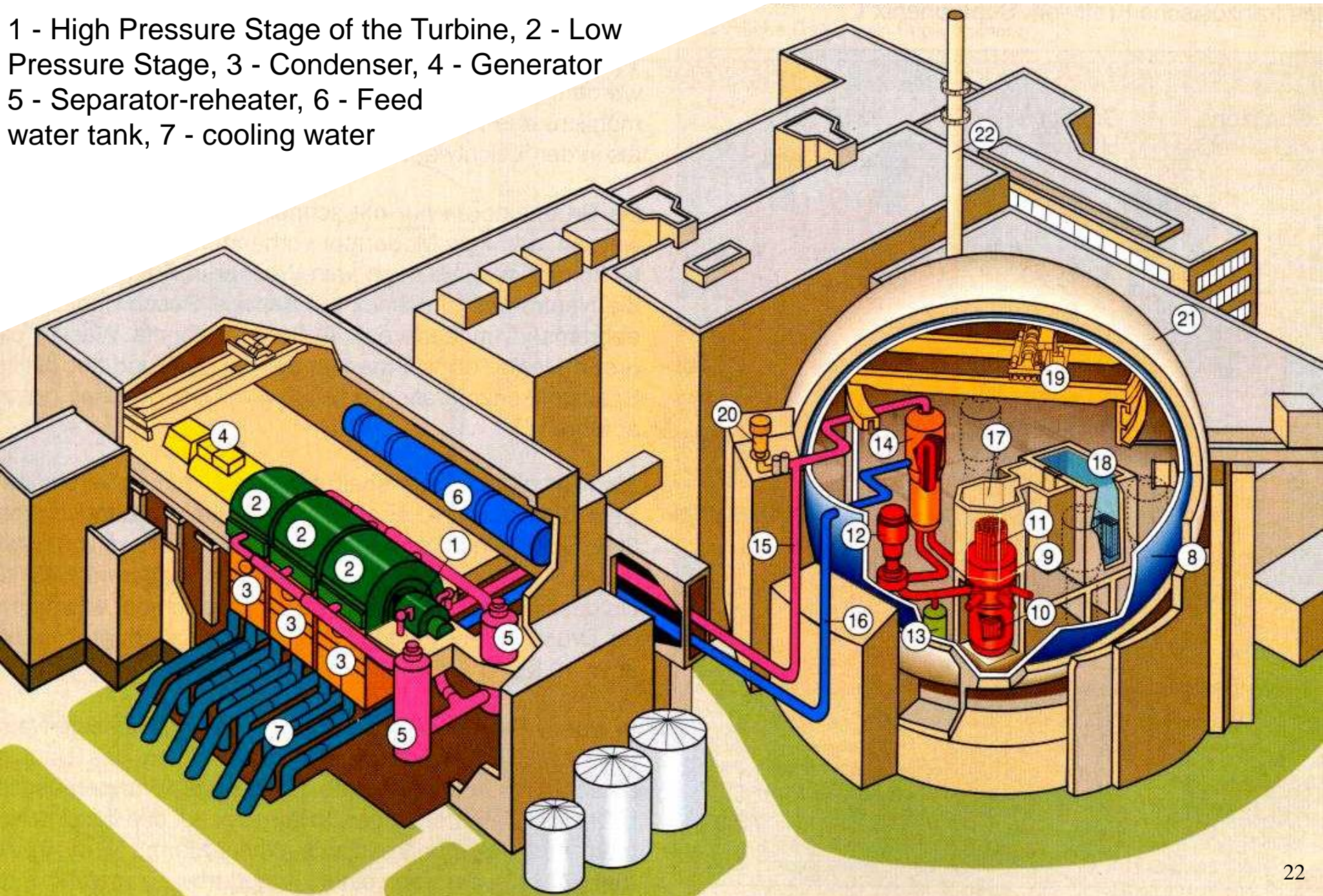

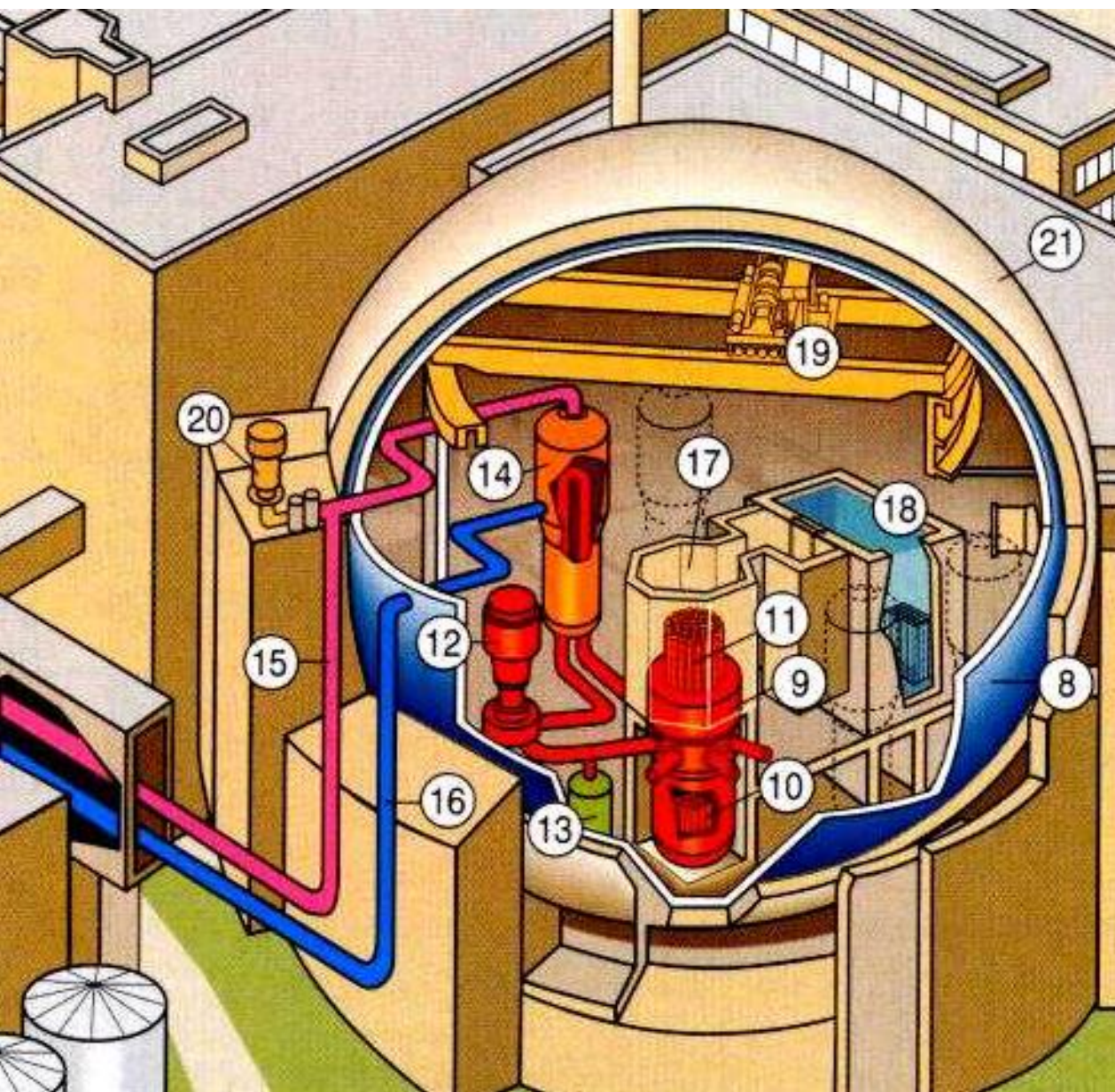

- 8 - Containment steel liner
- 9 - Reactor
- 10 - Core
- 11 - Reactor head with control rod drives
- 12 - Main coolant pump
- 13 - Pressurizer
- 14 - Steam generator
- 15 - Main steam line
- 16 - Feed water line
- 17 - Reactor basin
- 18 - Spent fuel basin
- 19 - Crane
- 20 - Containment isolation valve
- 21 - Containment shell

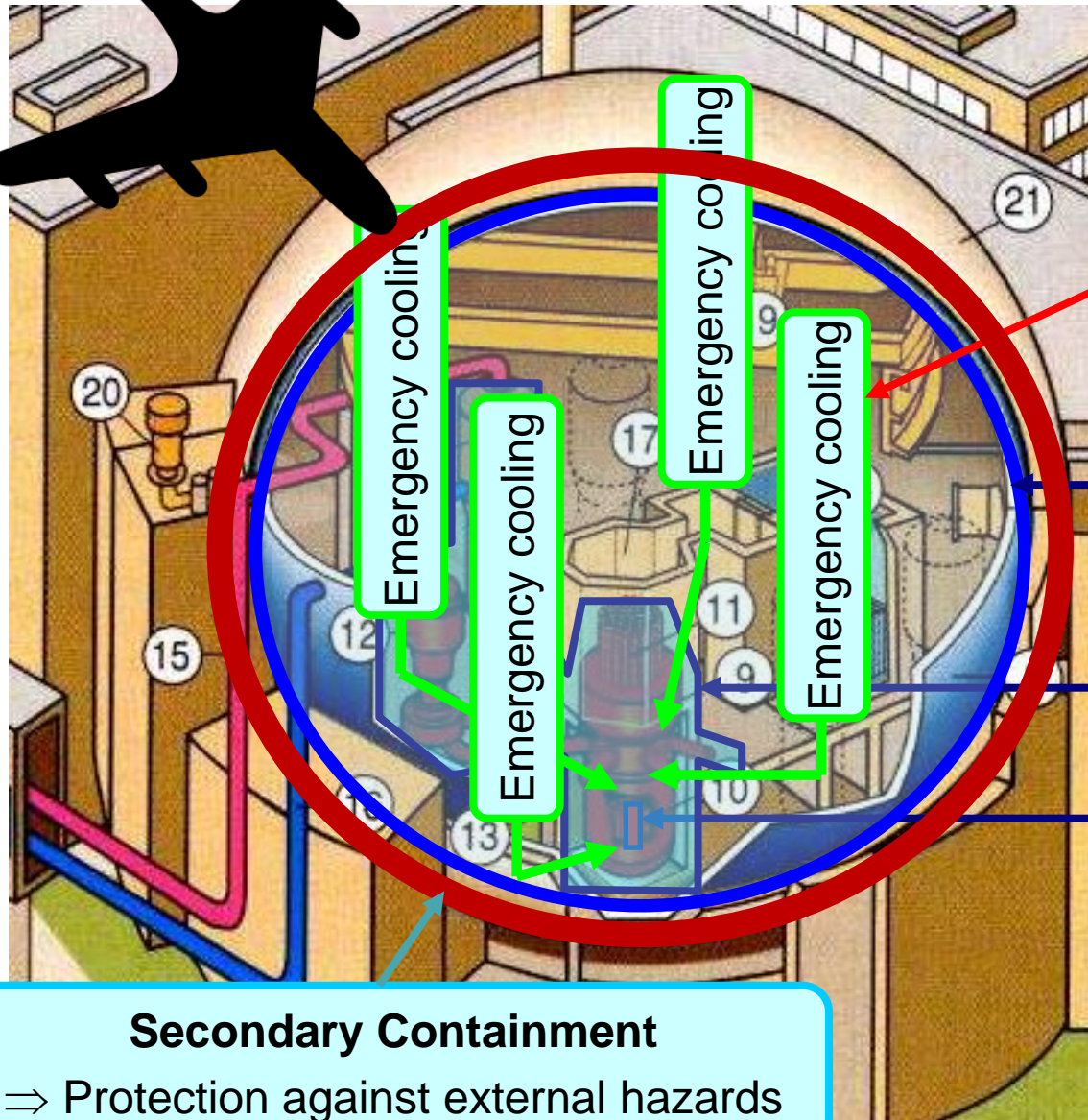
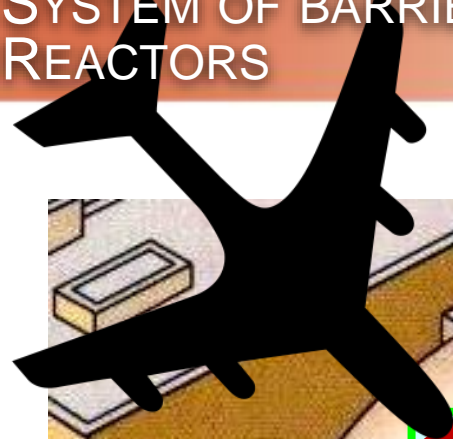

Safety systems:
Emergency shutdown
Emergency cooling

3. Barrier:
Inner Containment

2. Barrier:
Walls of reactor circuit

1. Barrier:
Fuel rod cladding

Secondary Containment
⇒ Protection against external hazards

Source of figure: Basiswissen Kernenergie, Volkmer

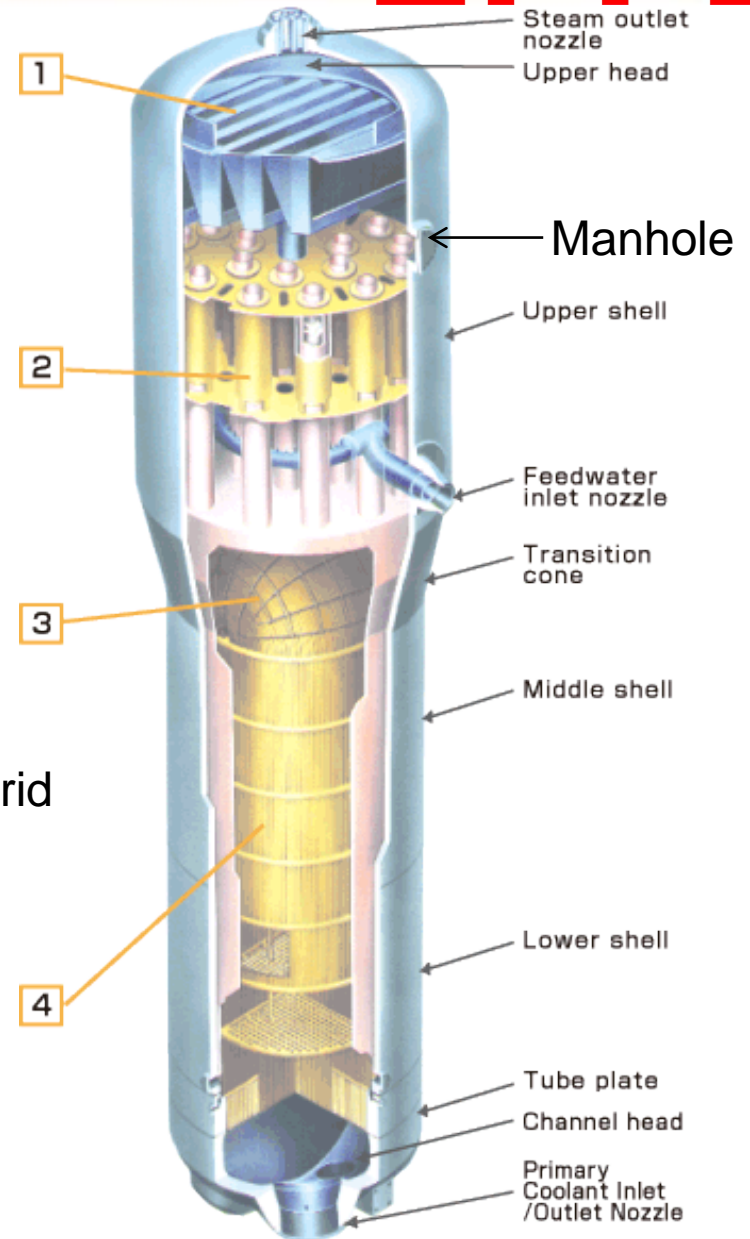
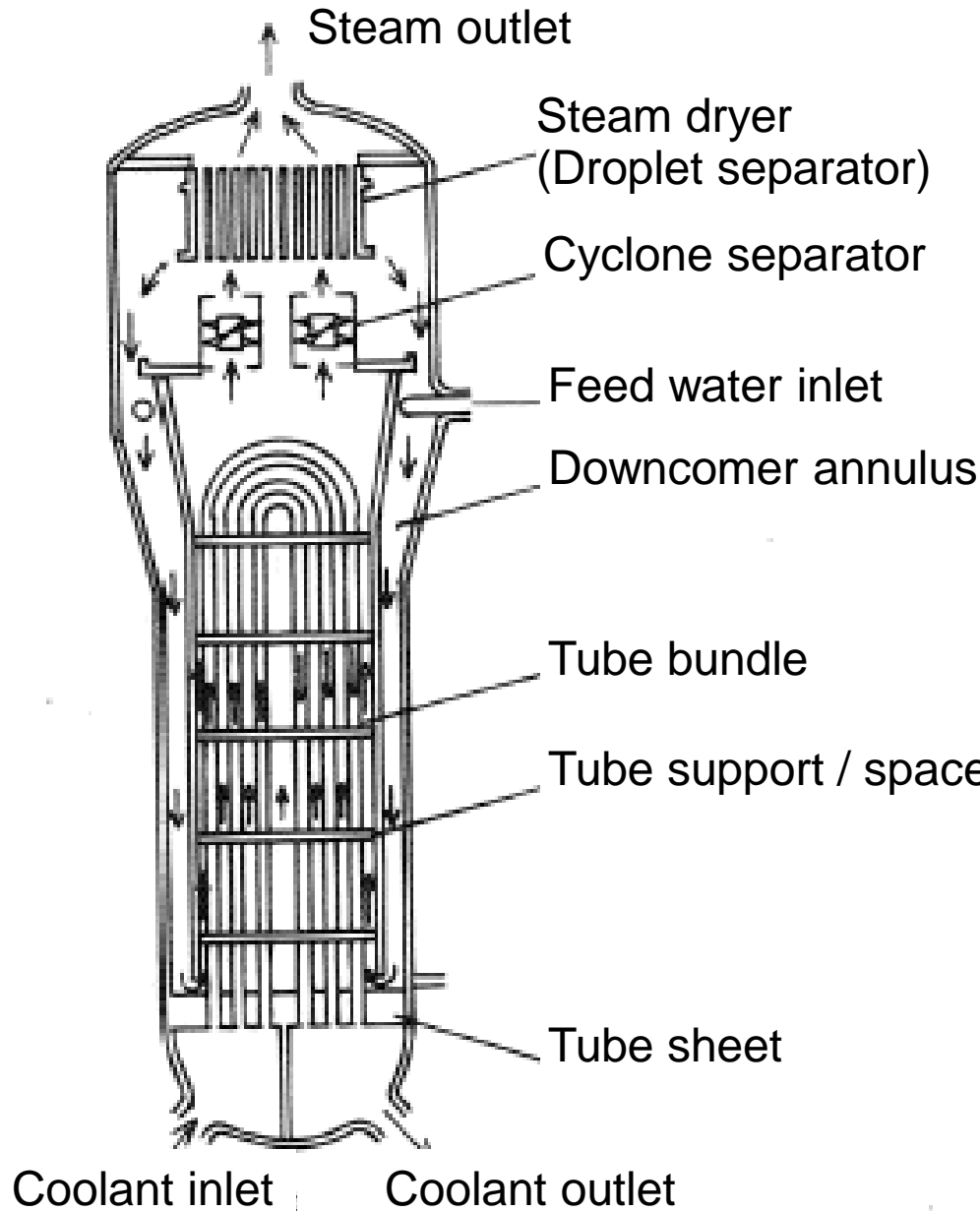

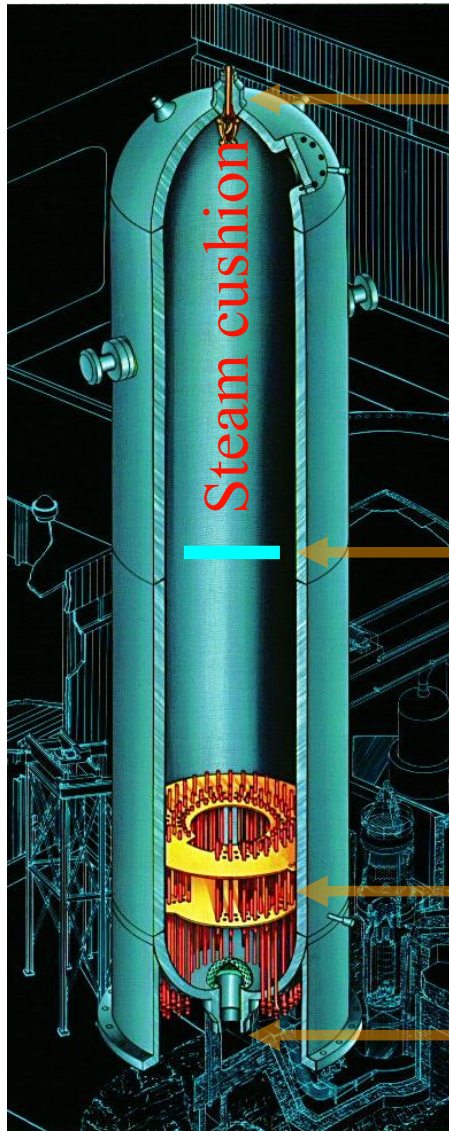

Injection
nozzle

Water level

Heating

Connection to
primary circuit

Task of the pressurizer:

- Expansion vessel for the primary circuit
- Guarantees “soft” response of pressure to thermal expansion of coolant at temperature / power changes

Function:

- Vessel partially filled with compressible fluid (gas, vapor)

Option A: Nitrogen cushion in first PWRs

- Costly nitrogen supply system needed (-)
- Lower compressibility than vapor cushion (-)
- Nitrogen ingress into primary circuit (-)

Option B: Steam cushion in modern PWRs

- Higher compressibility by phase change (+)
- Power needed for heaters, ca. 1 MWel (-)

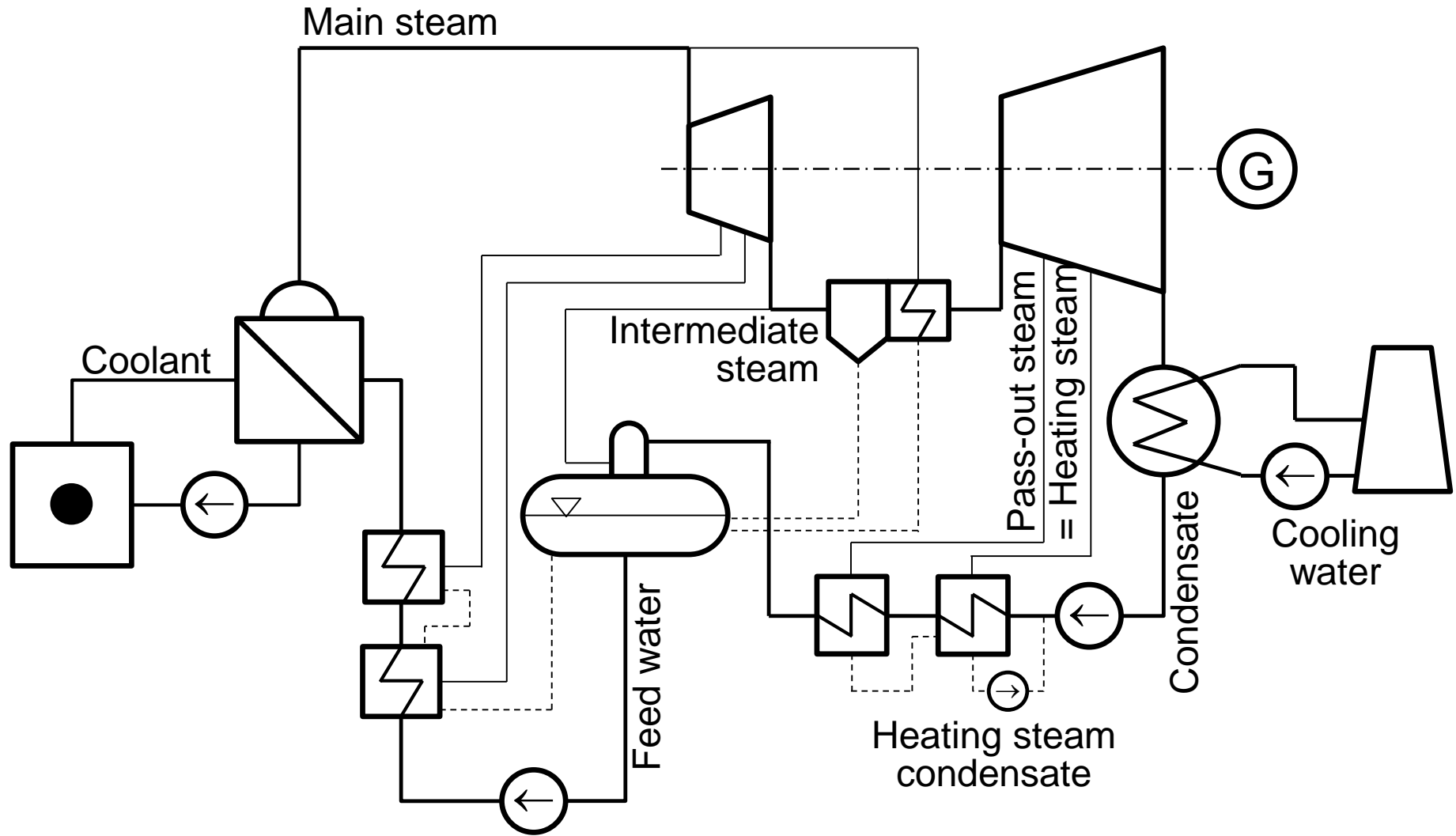

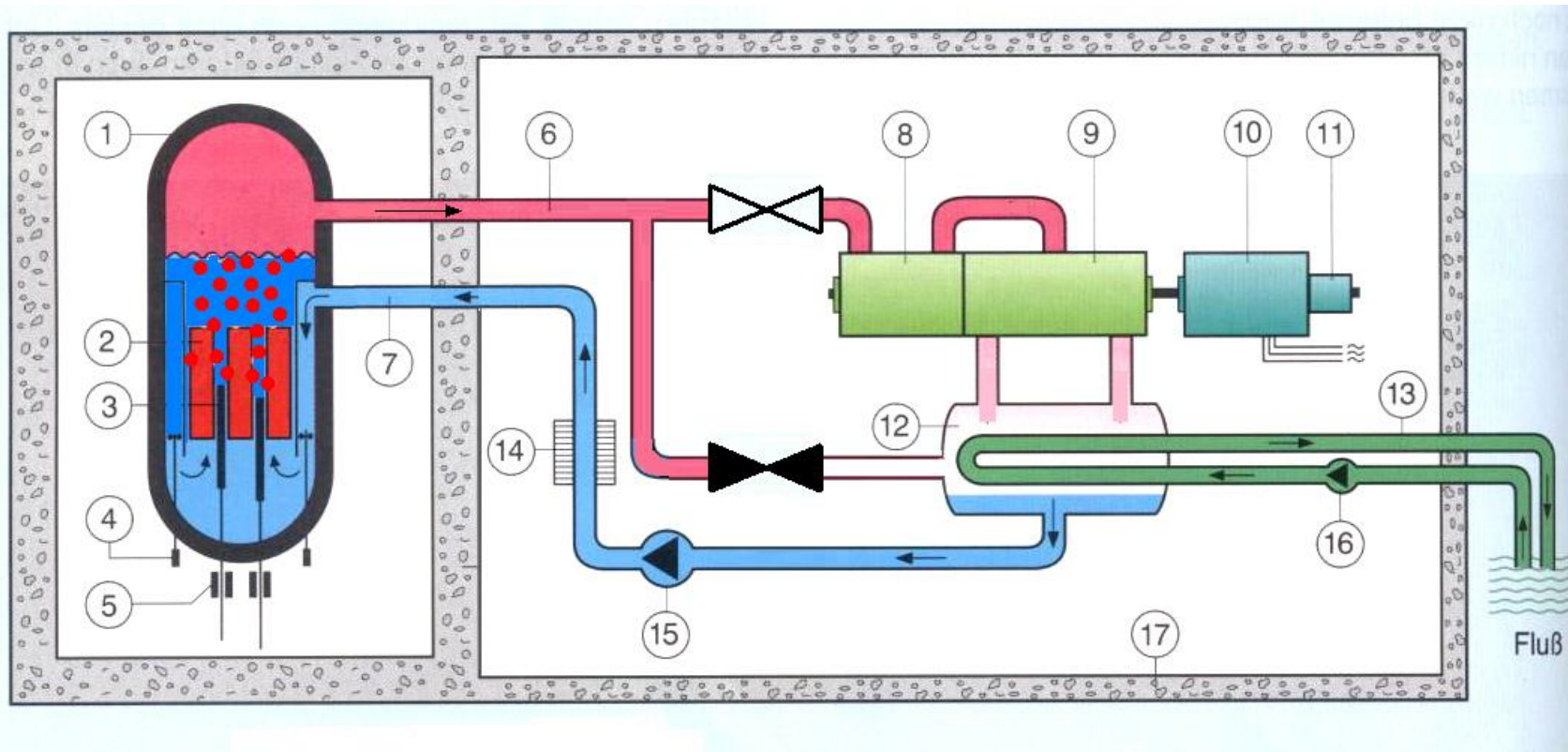

- 1 - Reactor Pressure Vessel, 2 - Fuel Elements, 3 - Control Rods, 4 - Circulation Pumps, 5 - Fuel Rod Drives, 6 - Main Steam Line, 7 - Feed water line, 8 - High Pressure Stage, 9 - Low Pressure Stage of the Turbine, 10 - Generator, 11 - Exciter, 12 - Condenser, 13 - River Cooling, 14 - Regenerative Pre-Heater Stages, 15 - Feed water Pump, 16 - Cooling Water Pump, 17 - Concrete Shielding

Spray nozzle

(HERE: NPP LEIBSTADT)

- Crane hook for steam dryers
- Steam dryers (droplet separators)
- Steam outlet nozzle
- Cyclone separators
- Core spray inlet nozzle (safety)
- Low pressure injection nozzle (safety)
- Upper core grid
- Jet pumps
- Shutdown cooling inlet
- Pressure vessel support
- Radiation protection wall
- Control rod drives
- Neutron flux instrumentation

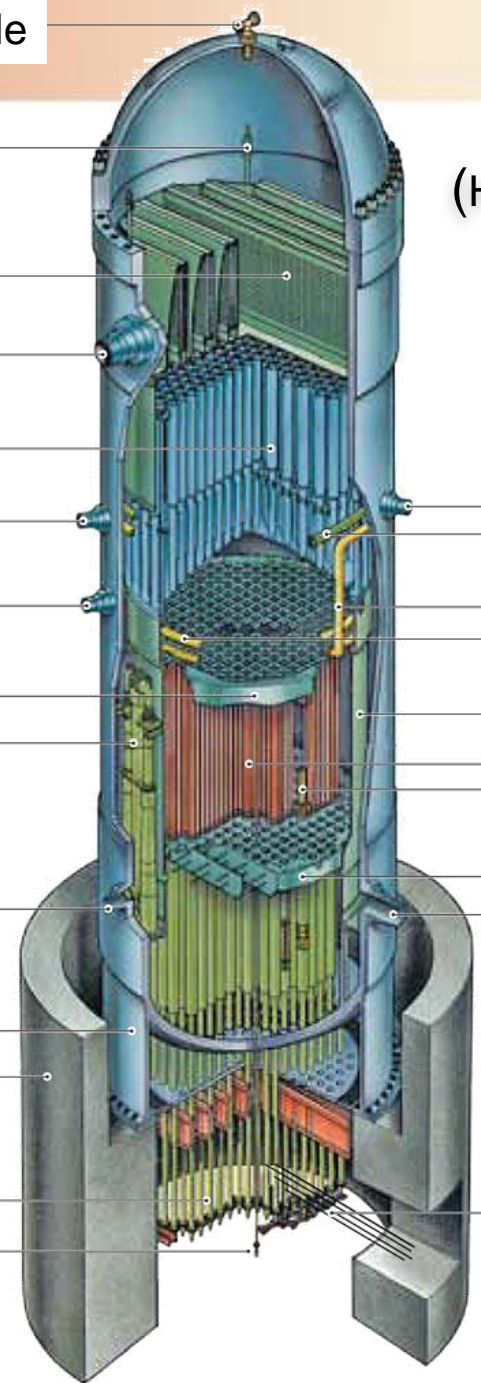

- Feed water inlet nozzle
- Feed water manifold
- Core spray manifold (safety)
- Core spray nozzle ring (safety)
- Core barrel
- Fuel elements
- Control rod
- Core support plate
- Shutdown cooling outlet

Control rod drive supply lines

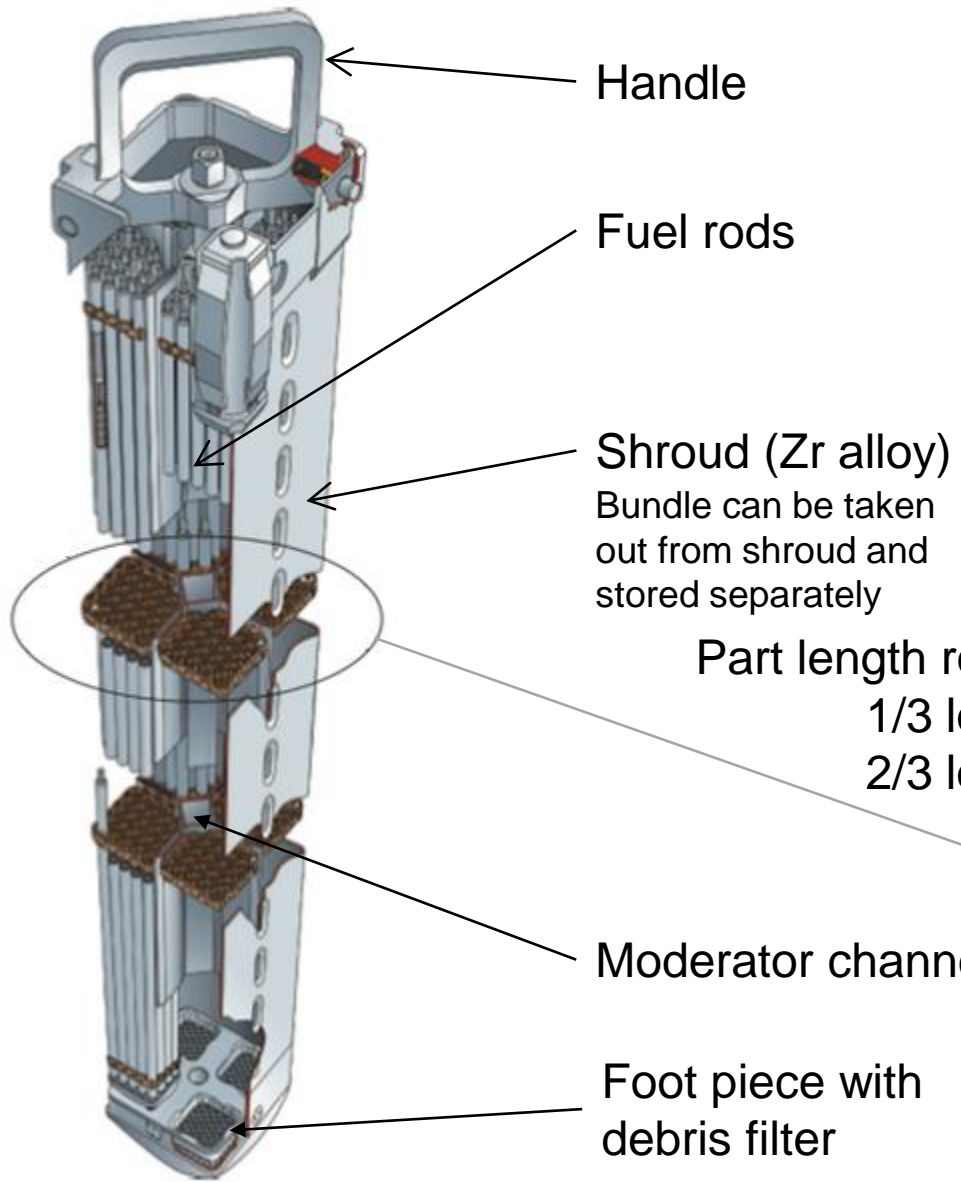

1/4 of the core of NPP Leibstadt

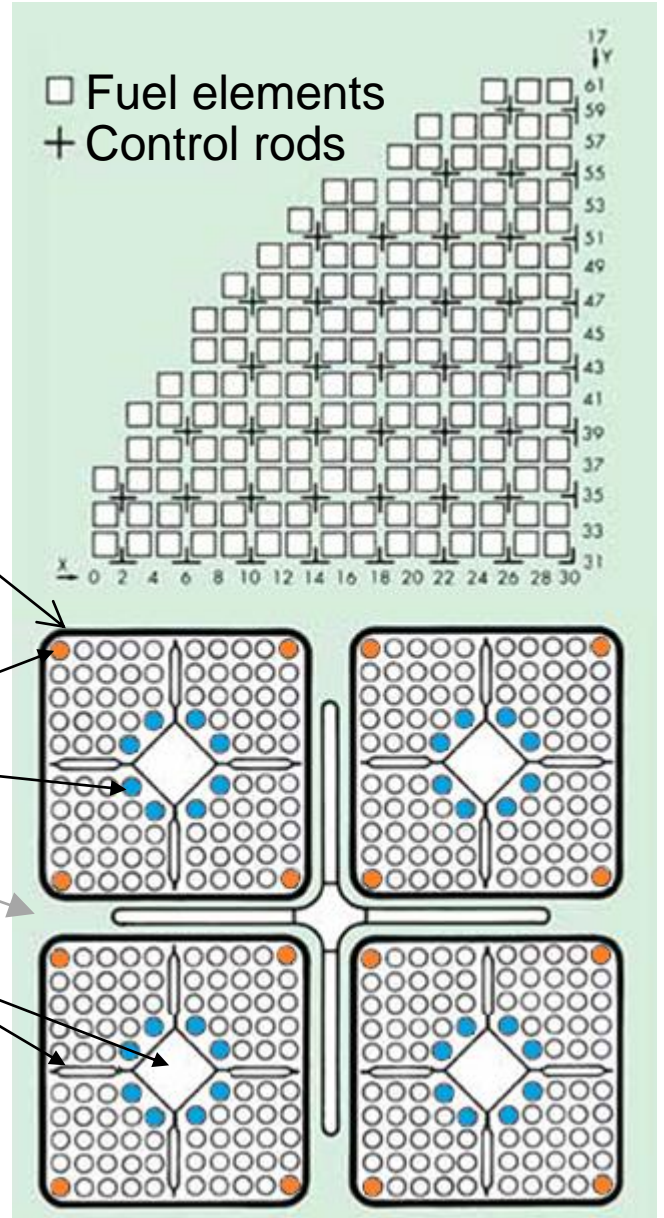
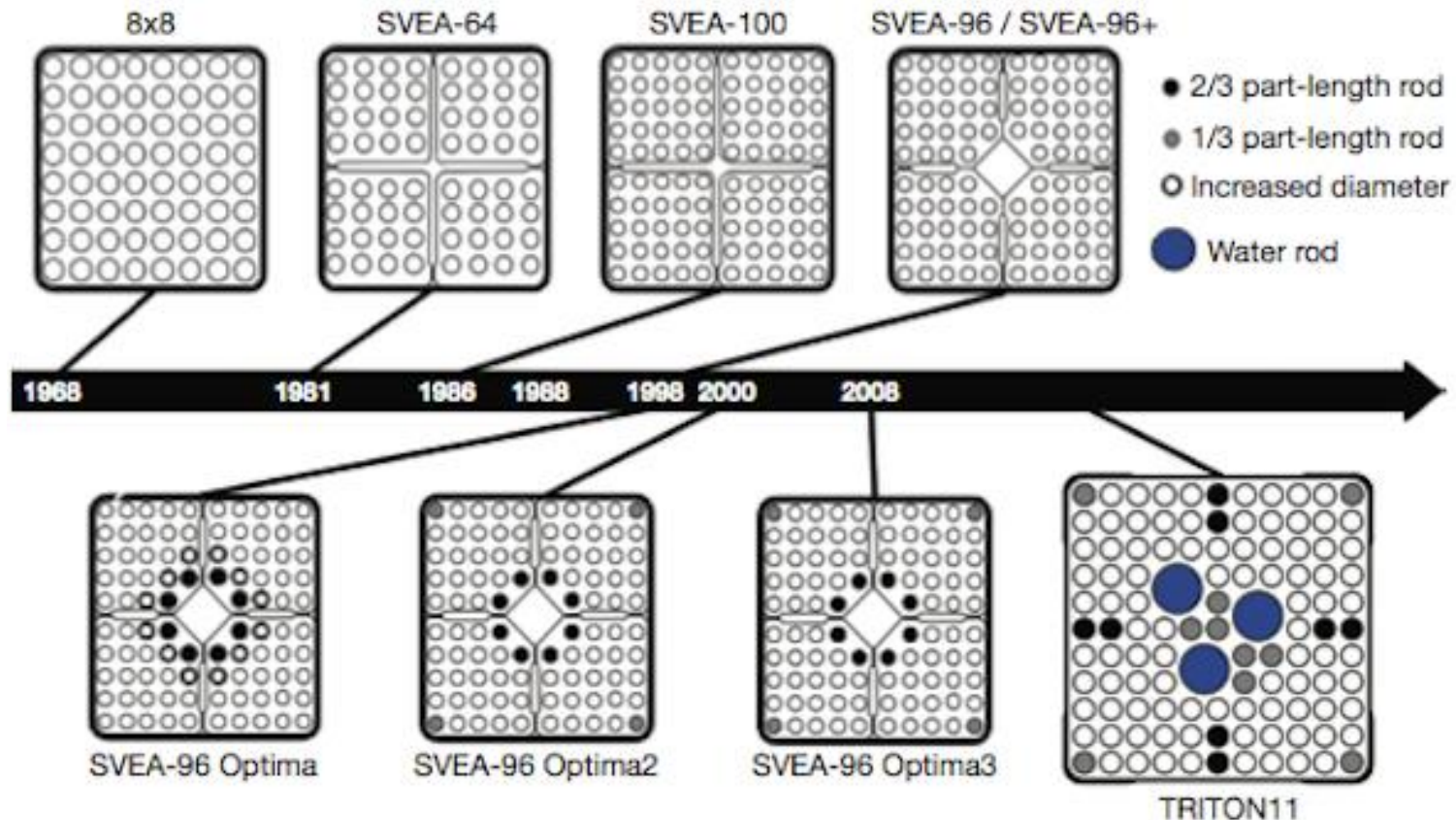

Figure: Westinghouse (SVEA Optima 2 FE)

- **Water channels + Part-length fuel rods** improve moderation in the upper part of the fuel elements (where steam generation strongly decreases the moderator density)
- **Control rods inserted from below** shift the power peak upwards



Average steam fraction at core outlet 100 % → dryout in the central fuel elements!

- Cooling insufficient
- Bad moderation

Circulation increases water content in core

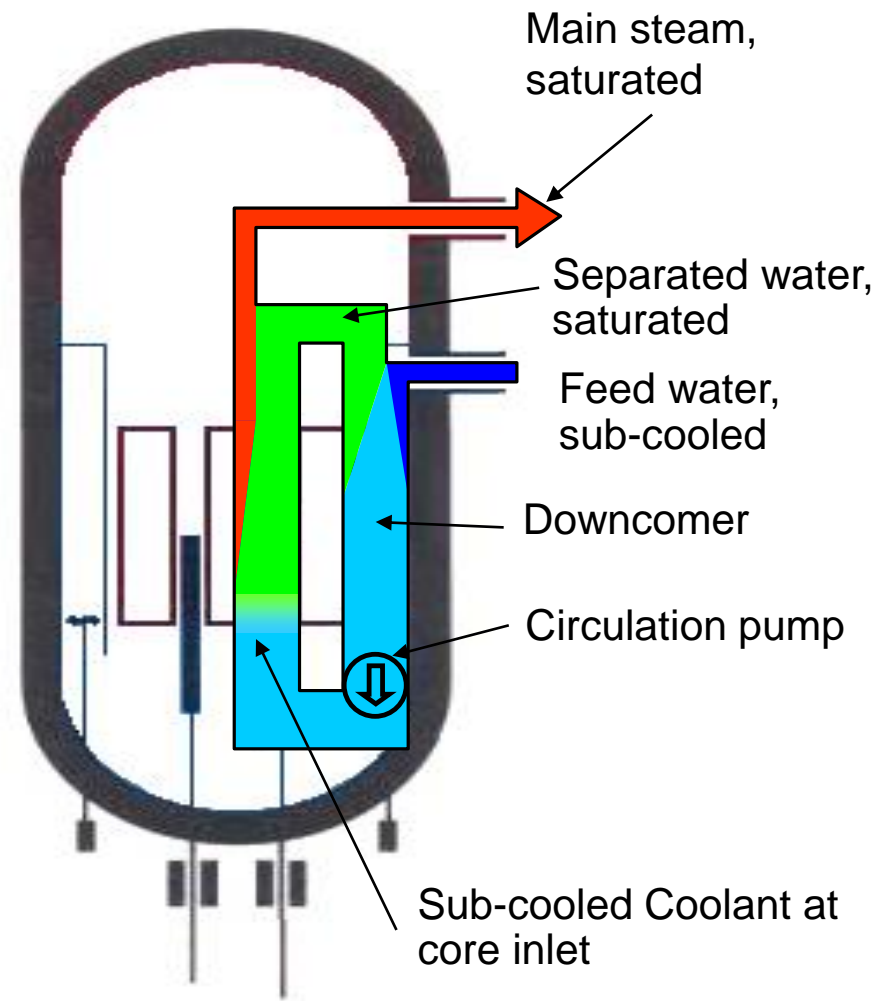
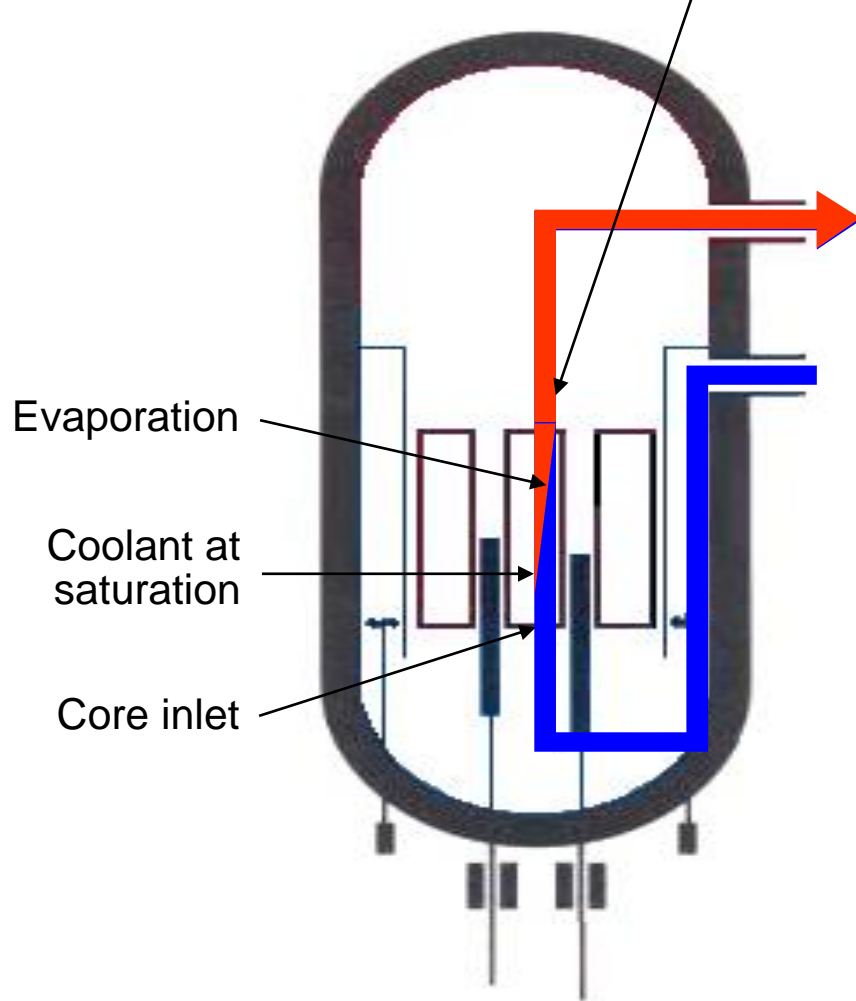

Purpose: Reduce number of water droplets to prevent damage to the turbine blades

- Steam Dryers
 - Increase steam quality to 99.9+%
- Steam Separators
 - Increase steam quality to 95%

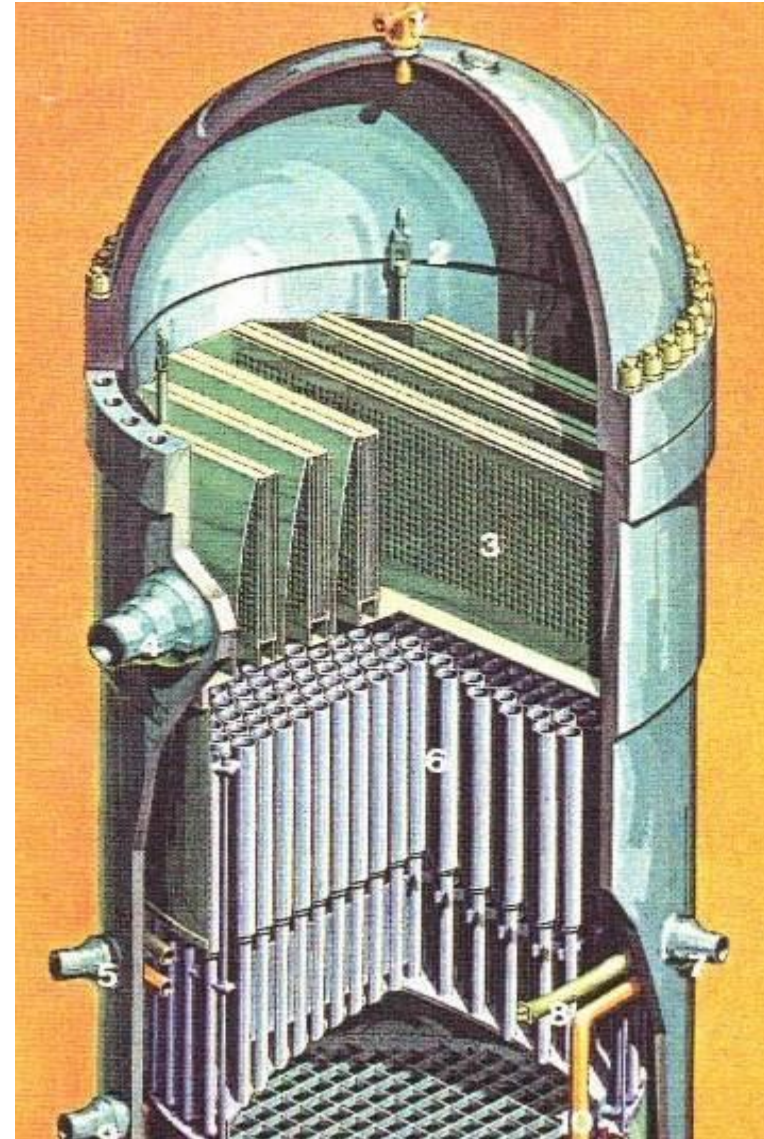

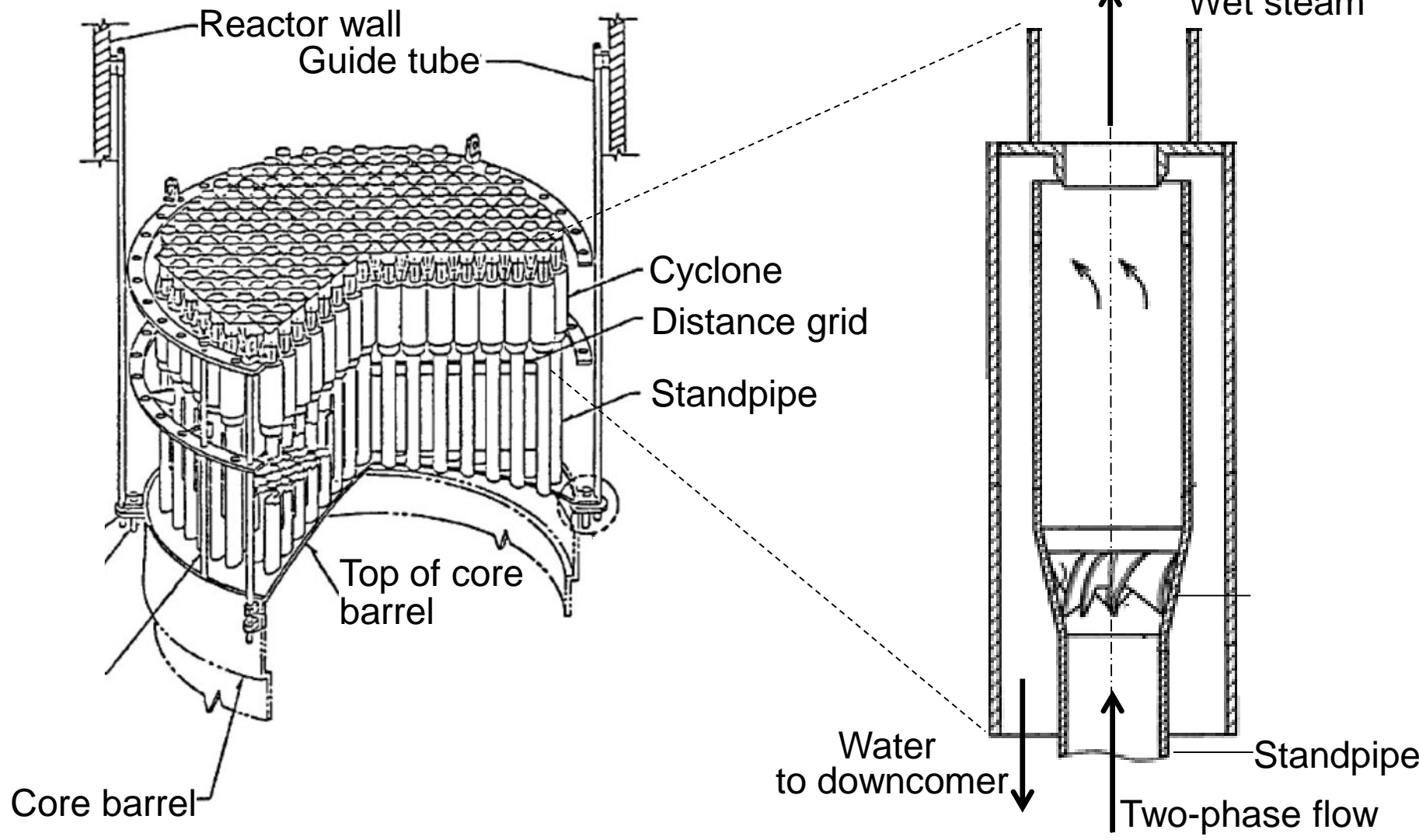

- Centrifugal forces caused by swirl transport water to the periphery of the cyclone
- Separated water runs down to the downcomer

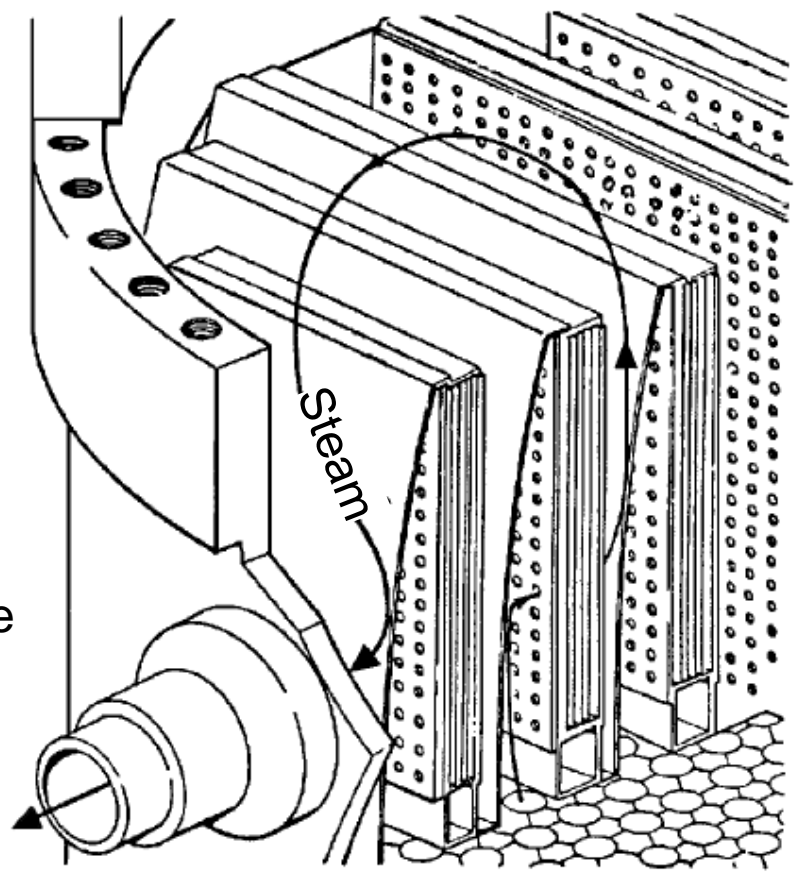
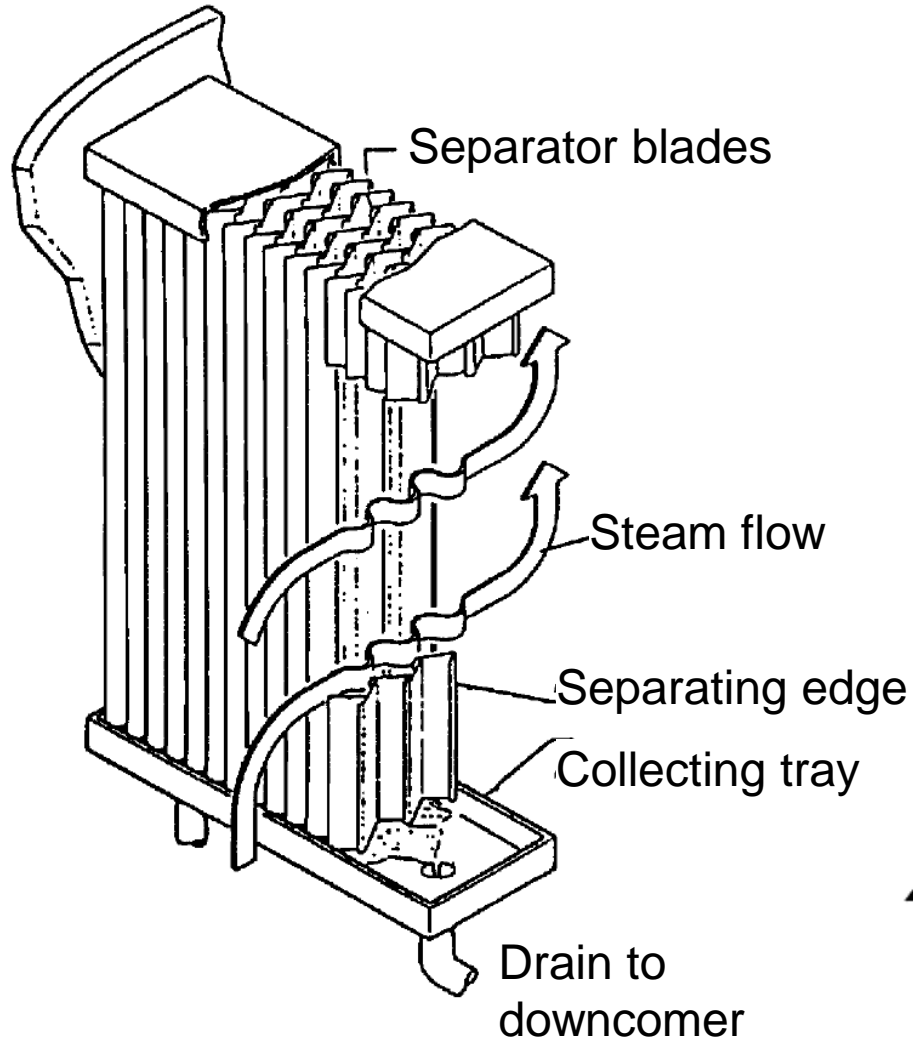

- Water droplets do not follow flow direction changes and impact the separator blades just after the bends
- Separated water runs down the blades and is drained to the downcomer

- 1 - High Pressure Stage of the Turbine, 2 - Low pressure Stage, 3 - Condenser, 4 - Generator
- 5 - Separator-reheater, 6 - Cooling water lines, 7 - Main steam line, 8 - Feed water line,
- 9 - Safety tank (containment), 10 - Reactor, 11 - Core, 12 - Pump
- 13 - Control rod drives, 14 - Reactor basin
- 15 - Spent fuel basin, 16 - Reactor hall
- 17 - Pressure suppression pool
- 18 - Ventilation chimney

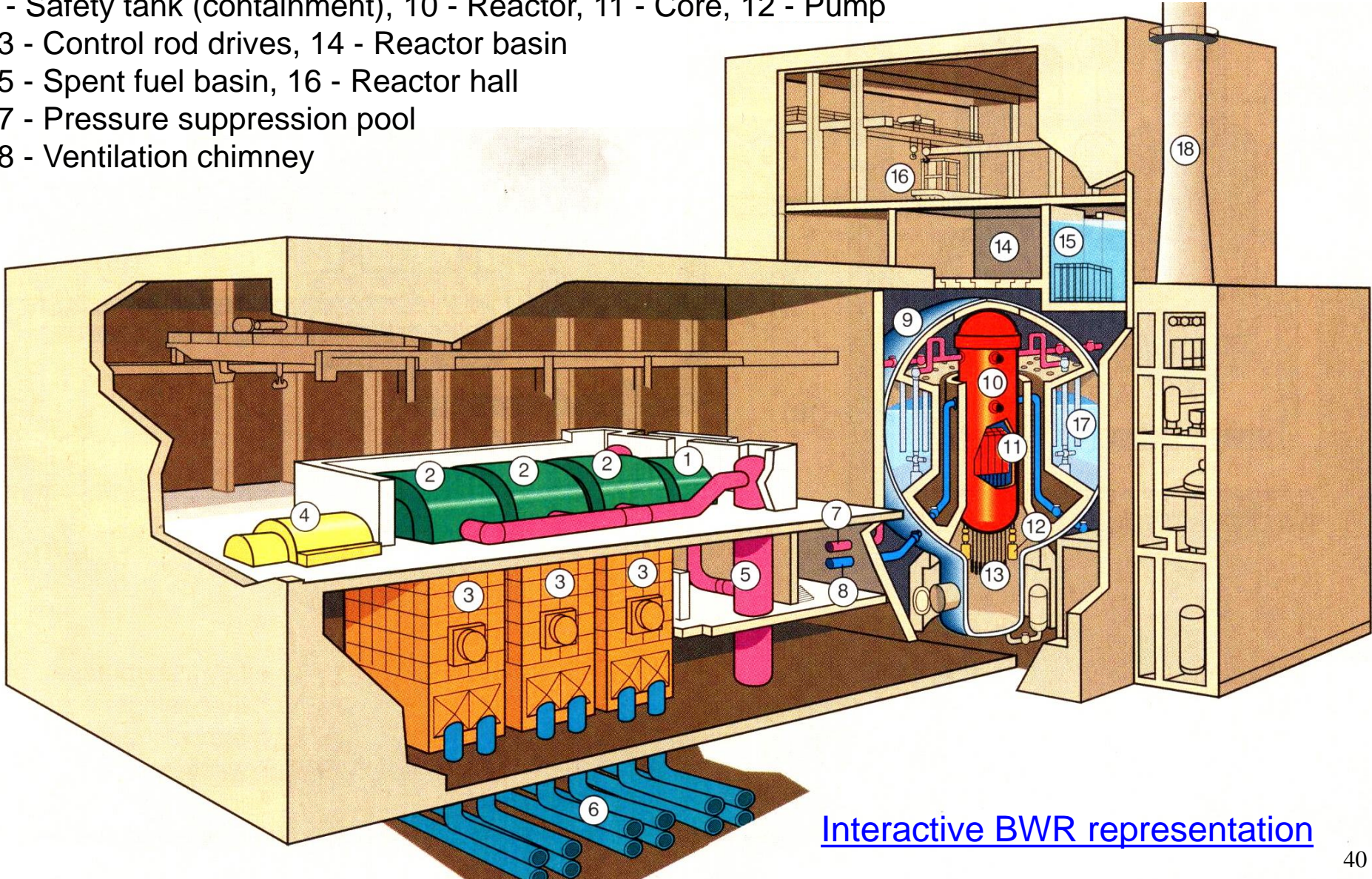

[Interactive BWR representation](#)

	PWR	BWR
Turbine + equipment	not activated	activated, control area
Maintenance costs in containment	higher	lower
Maintenance costs at turbine	lower	higher
Interior space, size of containment	large	smaller
Complexity of reactor facility	higher, SG, Pumps	lower
Investment costs	higher	lower
Reactor pressure at equal steam pressure	higher RPV wall thickness	lower
Fuel economy	Slightly better	Slightly worse
Economy	comparable	