

PHYS-101 WEEK 6

MID-TERM COURSE FEEDBACK

Last day for course feedback!



FORCES IN THIS COURSE

- Fluid Friction
- Tension
- Hooke's Law**
- Archimedes' Principle (Buoyant Force)
- Gravity*
- Static (dry) Friction
- Static (dynamic) Friction
- Normal Force

*Full general description of gravity in week 12

**Full analysis of motion in weeks 10 & 11

ARCHIMEDES' PRINCIPLE

$$\vec{F}_A = -\rho V \vec{g}$$

QUIZ: WATER & ICE

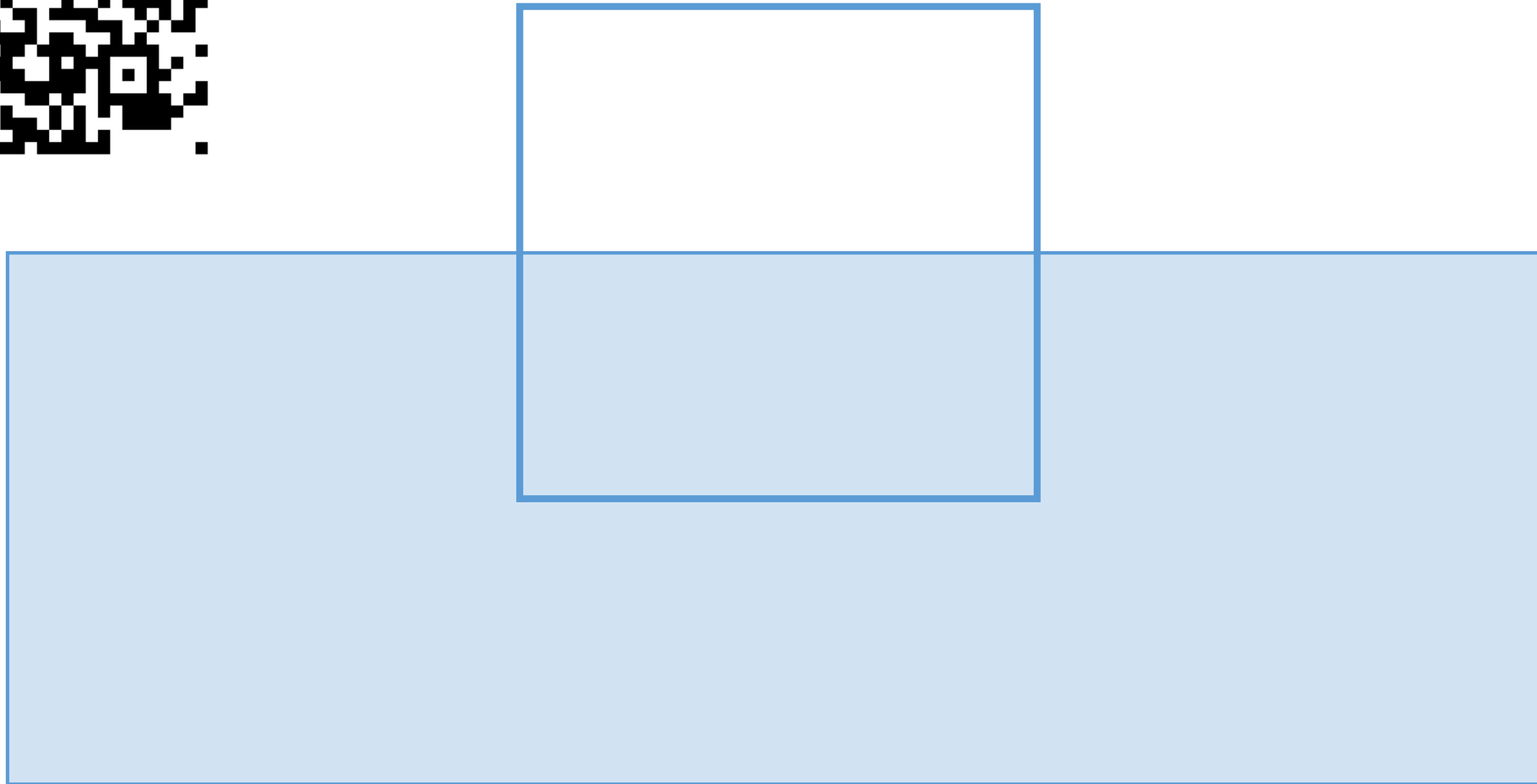

 An ice cube with mass m and volume V floats in water with density ρ_w . The ice cube is exactly half-submerged. What is the density of the ice ρ_i relative to the density of the water?

- $\rho_i = 4\rho_w$ 0%
- $\rho_i = 2\rho_w$ 0%
- $\rho_i = \rho_w$ 0%
- $\rho_i = \rho_w / 2$ 0%
- $\rho_i = \rho_w / 4$ 0%

ARCHIMEDES' PRINCIPLE

$$\vec{F}_A = -\rho V \vec{g}$$

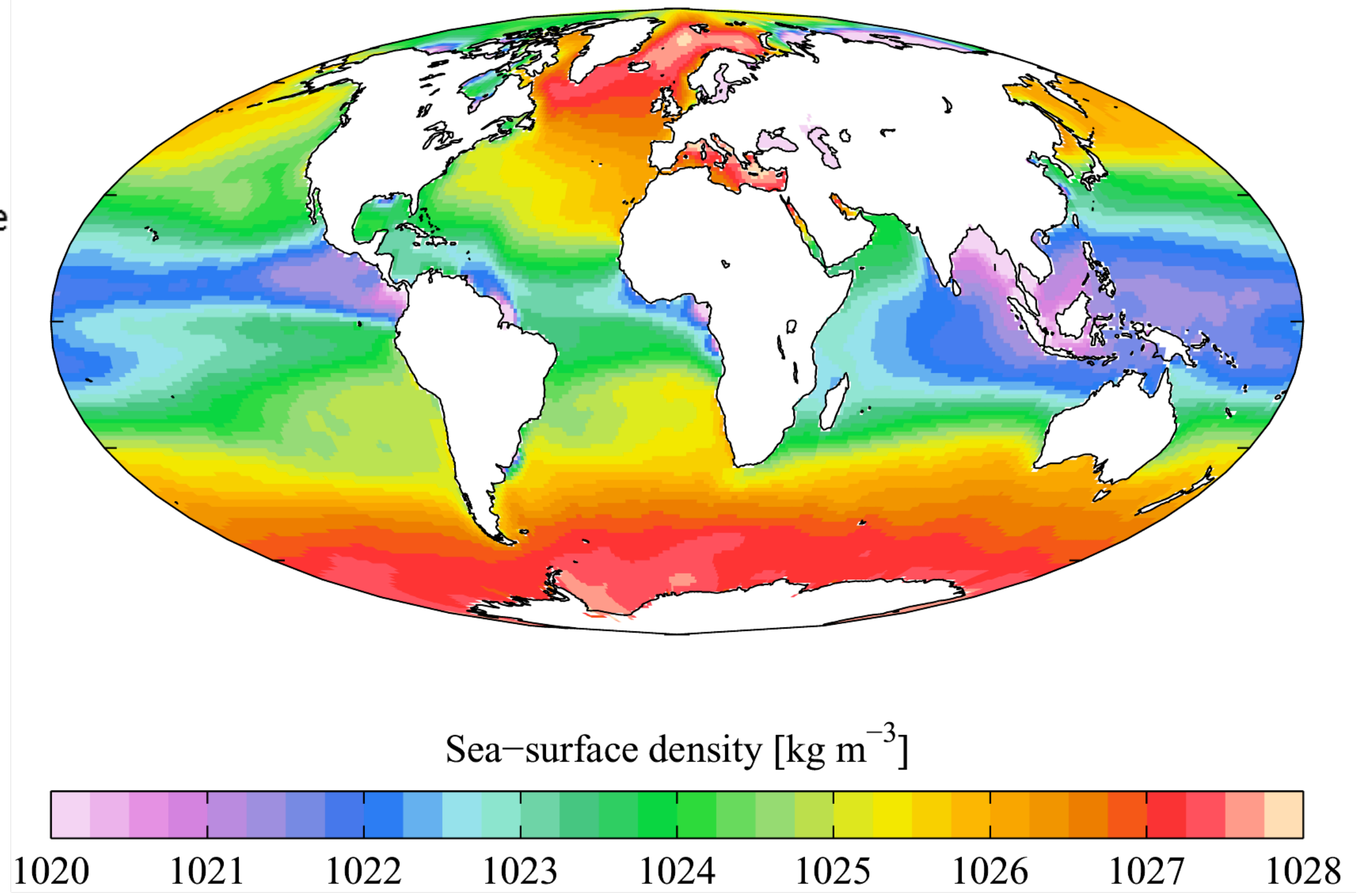
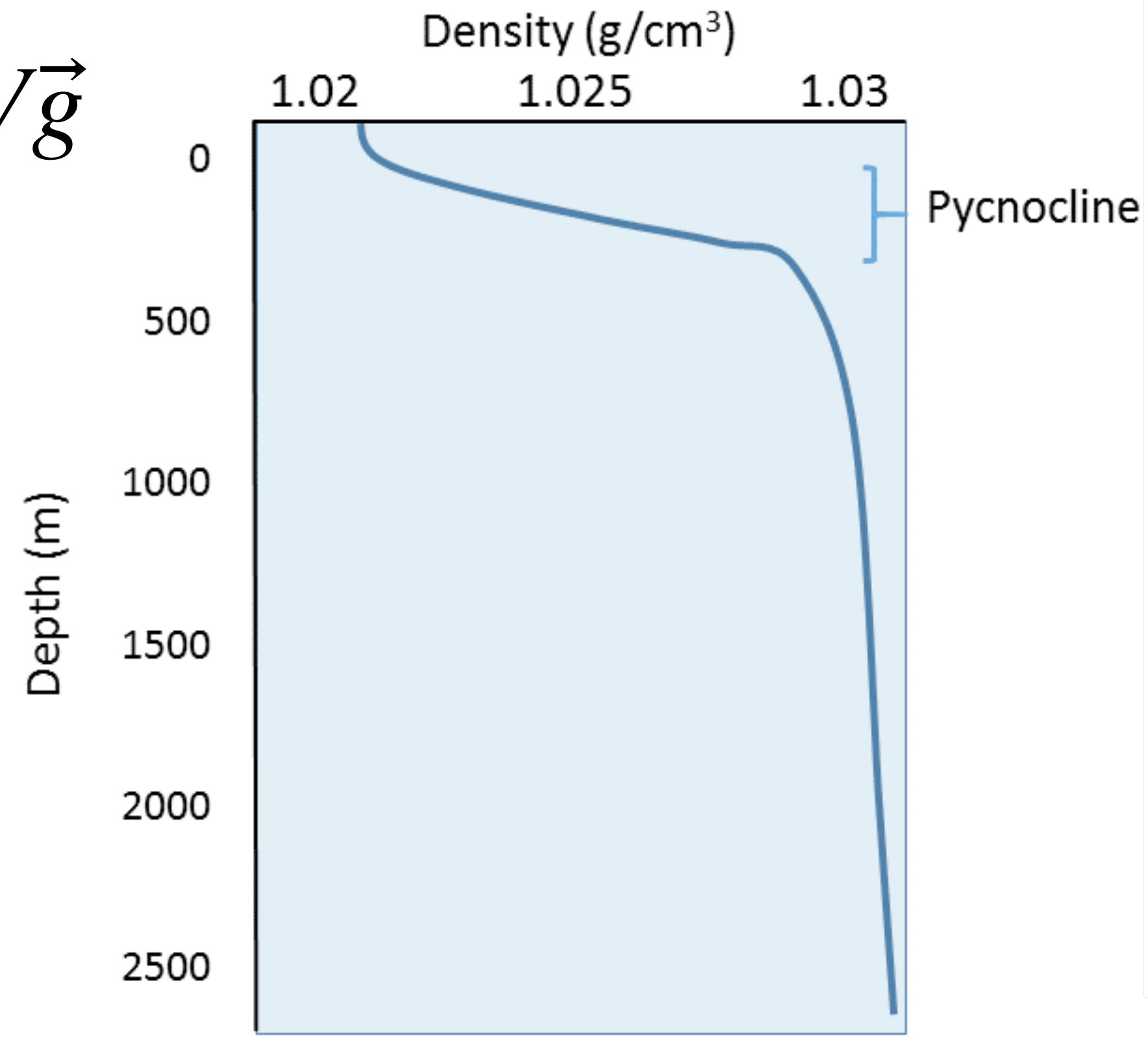

ARCHIMEDES' PRINCIPLE

$$\vec{F}_A = -\rho V \vec{g}$$

- Human body: $\sim 985 \text{ kg/m}^3$
- Lake Geneva: $\sim 1000 \text{ kg/m}^3$
- Ocean average: $\sim 1025 \text{ kg/m}^3$
- Mediterranean: 1028 kg/m^3
- Dead Sea: $\sim 1240 \text{ kg/m}^3$



FLUID FRICTION

- Laminar Regime

$$\vec{F}_f = -b_l \vec{v}$$

$$b_l = K\eta$$

- Turbulent Regime

$$\vec{F}_f = -b_t v^2 \frac{\vec{v}}{v}$$

FLUID FRICTION

- Laminar Regime

$$\vec{F}_f = -b_l \vec{v}$$

$$b_l = K\eta$$

- Turbulent Regime

$$\vec{F}_f = -b_t v^2 \frac{\vec{v}}{v}$$



FLUID FRICTION

- Laminar Regime

$$\vec{F}_f = -b_l \vec{v}$$

$$b_l = K\eta$$

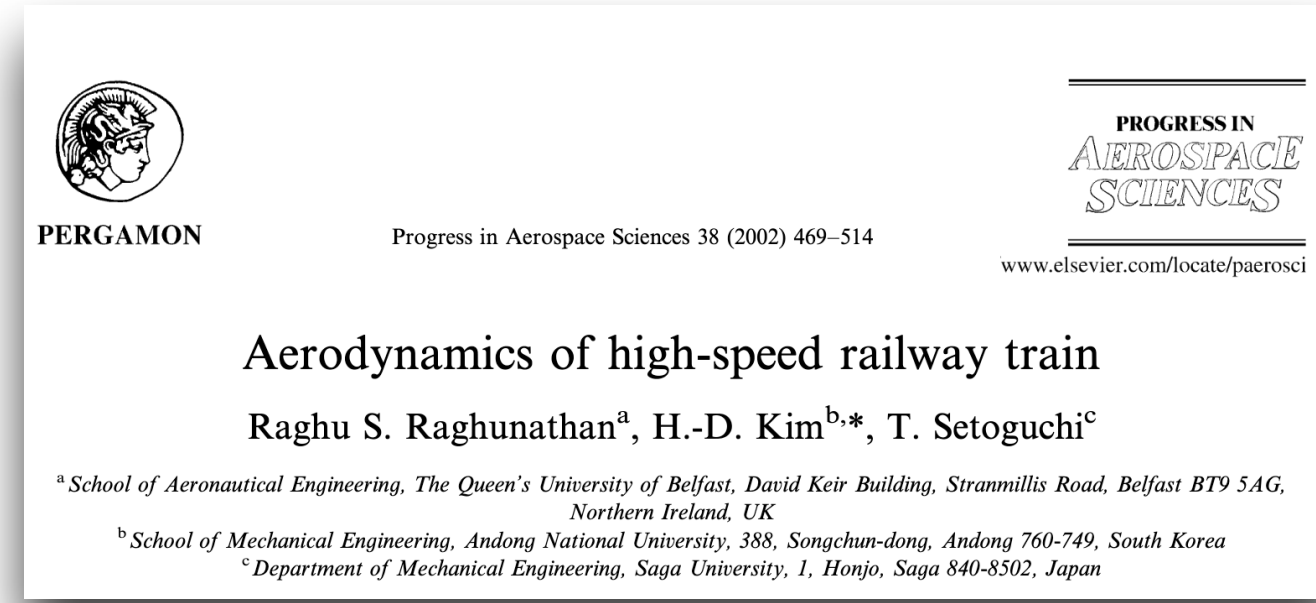

- Turbulent Regime

$$\vec{F}_f = -b_t v^2 \frac{\vec{v}}{v}$$

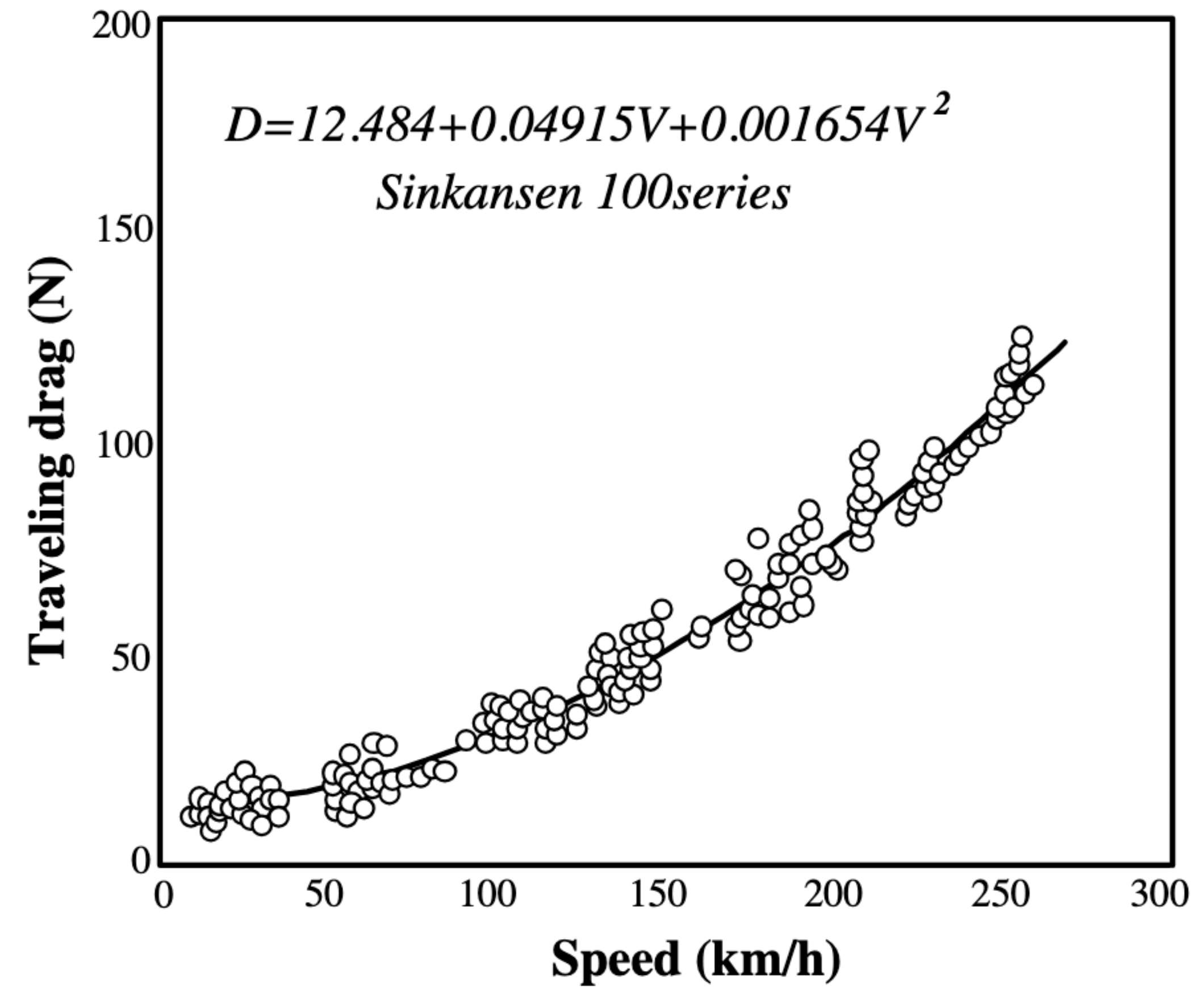

Fig. 6. Traveling drag on Shinkansen (series 100).

QUIZ: FALL TIME



Two spheres of the same diameter and the same type of external surface (materials) are dropped from a tower, but one of the spheres is **ten times heavier** than the other.

Taking into account air resistance but not the Earth's rotation, which sphere arrives first?

- The heaviest 0%
- The lightest 0%
- They arrive at the same time 0%

QUIZ: BALLISTICS

REVISITED



 A projectile is fired at angle α from a small cannon. If air resistance is taken into account, the trajectory is: ...

- The same as if air resistance is ignored 0%
- Still a parabola, but with a shorter range than if air resistance is ignored 0%
- A parabola with an inclined axis, not a vertical one 0%
- An asymmetrical bell curve that is not a parabola 0%

HOOKE'S LAW (SPRING FORCE)

$$\vec{F}_k = -k \Delta x \vec{e}_x$$

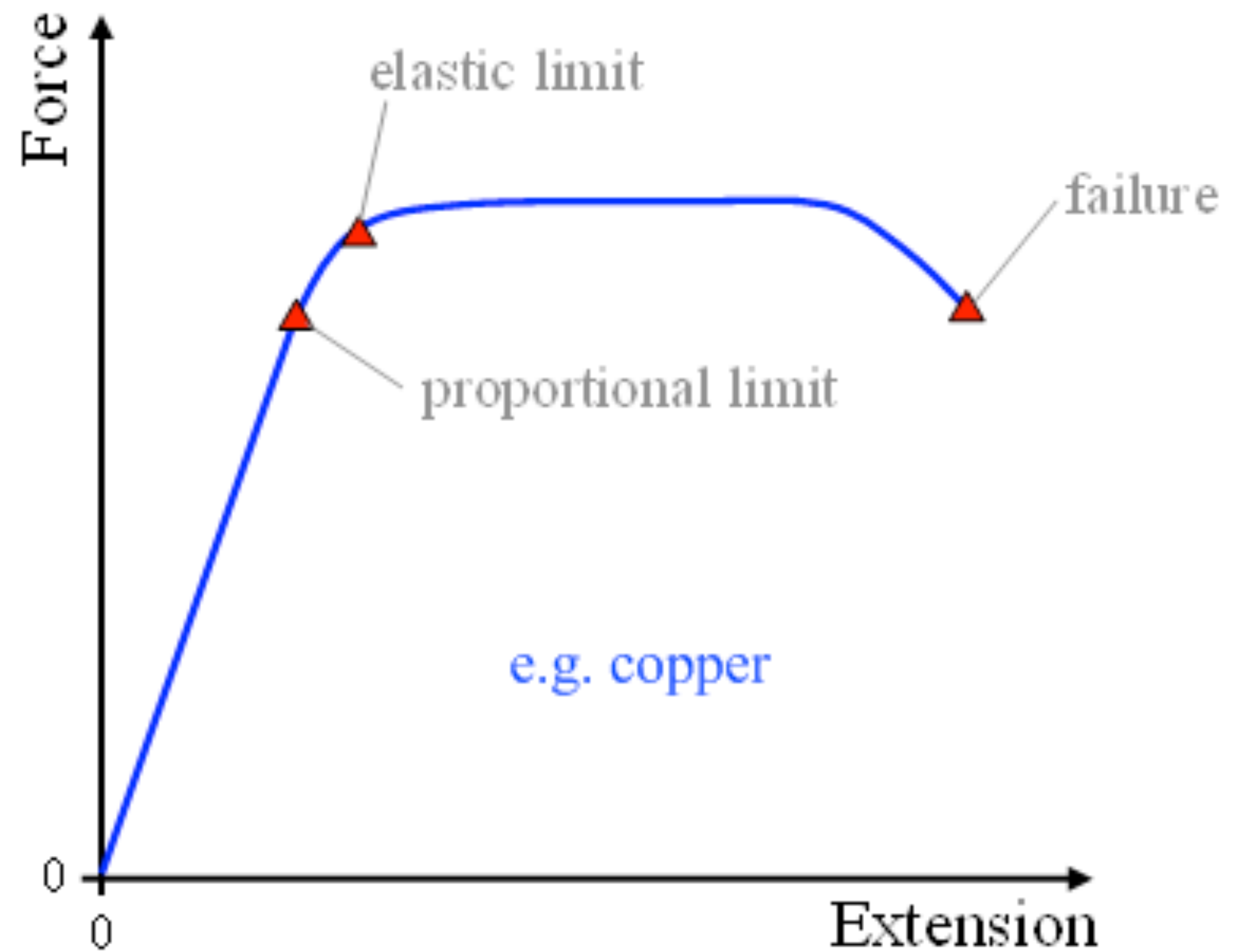

QUIZ: CEILING SPRING

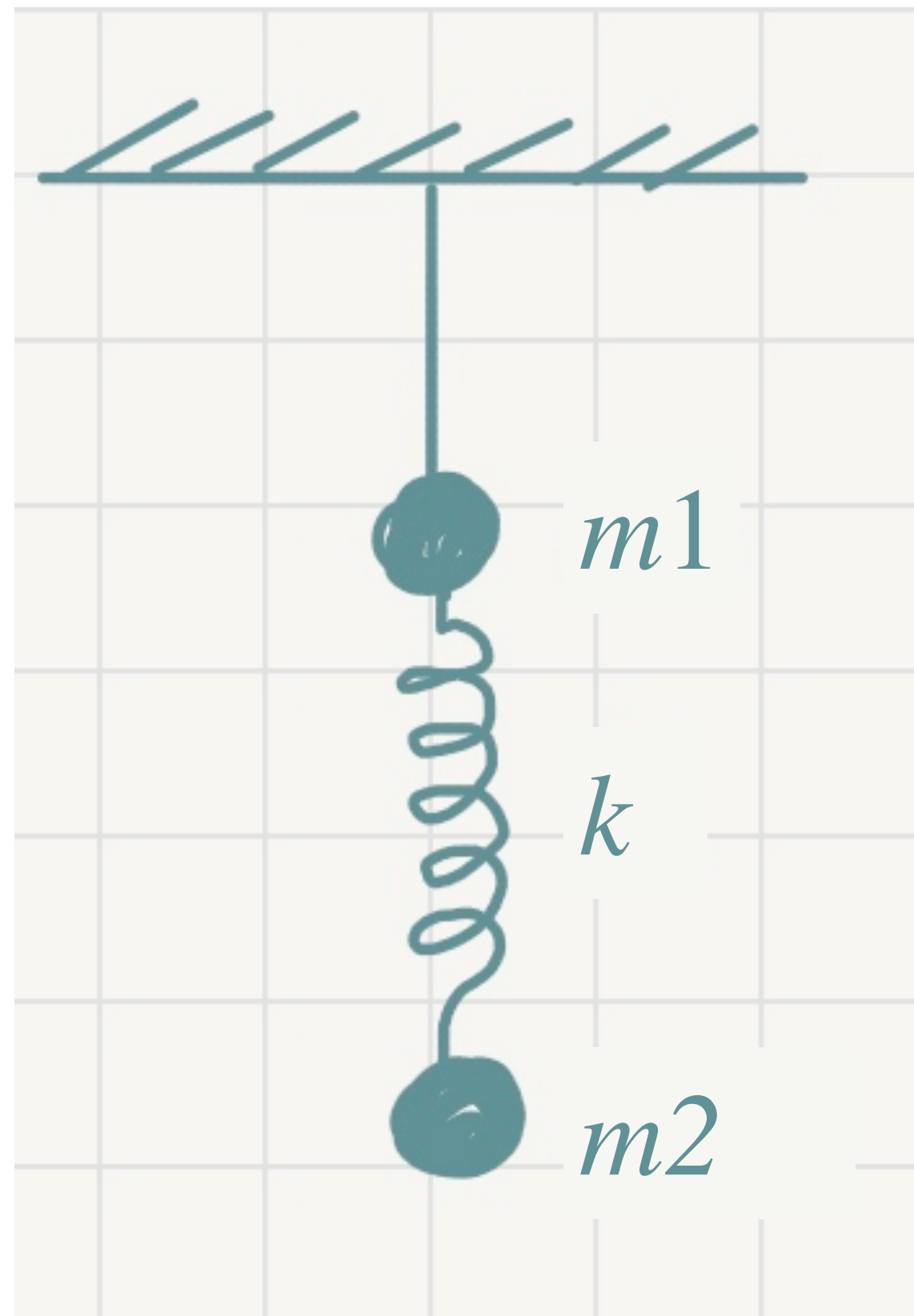

Consider two masses m_1 and m_2 connected by a spring and suspended from the ceiling by a wire. At $t = 0$, the wire is cut. Then, at $t = 0...$

- m_1 and m_2 both accelerate downwards 0%
- m_1 and m_2 both accelerate upwards 0%
- m_1 accelerates down and m_2 up 0%
- m_1 has zero acceleration, m_2 is accelerates down 0%
- m_1 is accelerates down; m_2 has zero acceleration 0%

TENSION

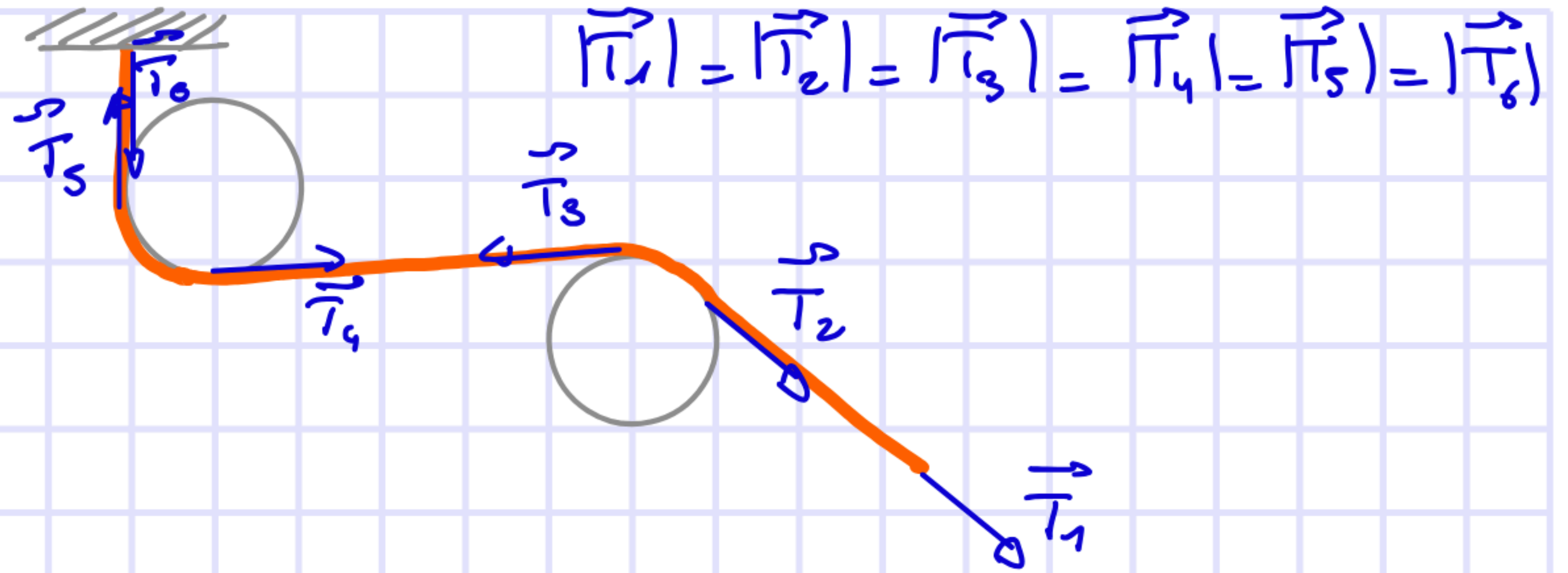
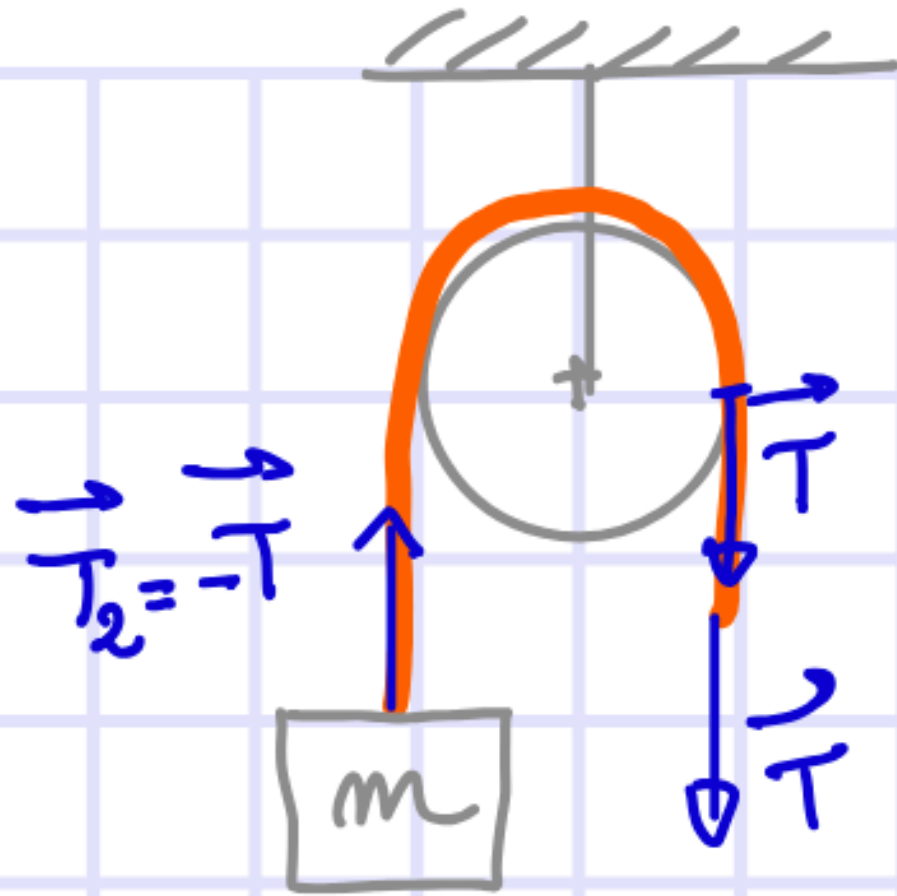

$$|\vec{T}_1| = |\vec{T}_2| = |\vec{T}_3| = |\vec{T}_4| = |\vec{T}_5|$$

QUIZ: MASSES & PULLEY



 We have two masses m_1 and m_2 , not necessarily the same. They are attached to a massless, inextensible, frictionless cord which goes around a massless pulley. Which statements about this system are correct?

- $|\vec{T}_1| = |\vec{T}_2|$ 0%
- $|\vec{T}_1| = |m_1 \vec{g}|$ 0%
- $|\vec{T}_2| = |m_2 \vec{g}|$ 0%
- $|m_1 \vec{g}| = |m_2 \vec{g}|$ 0%

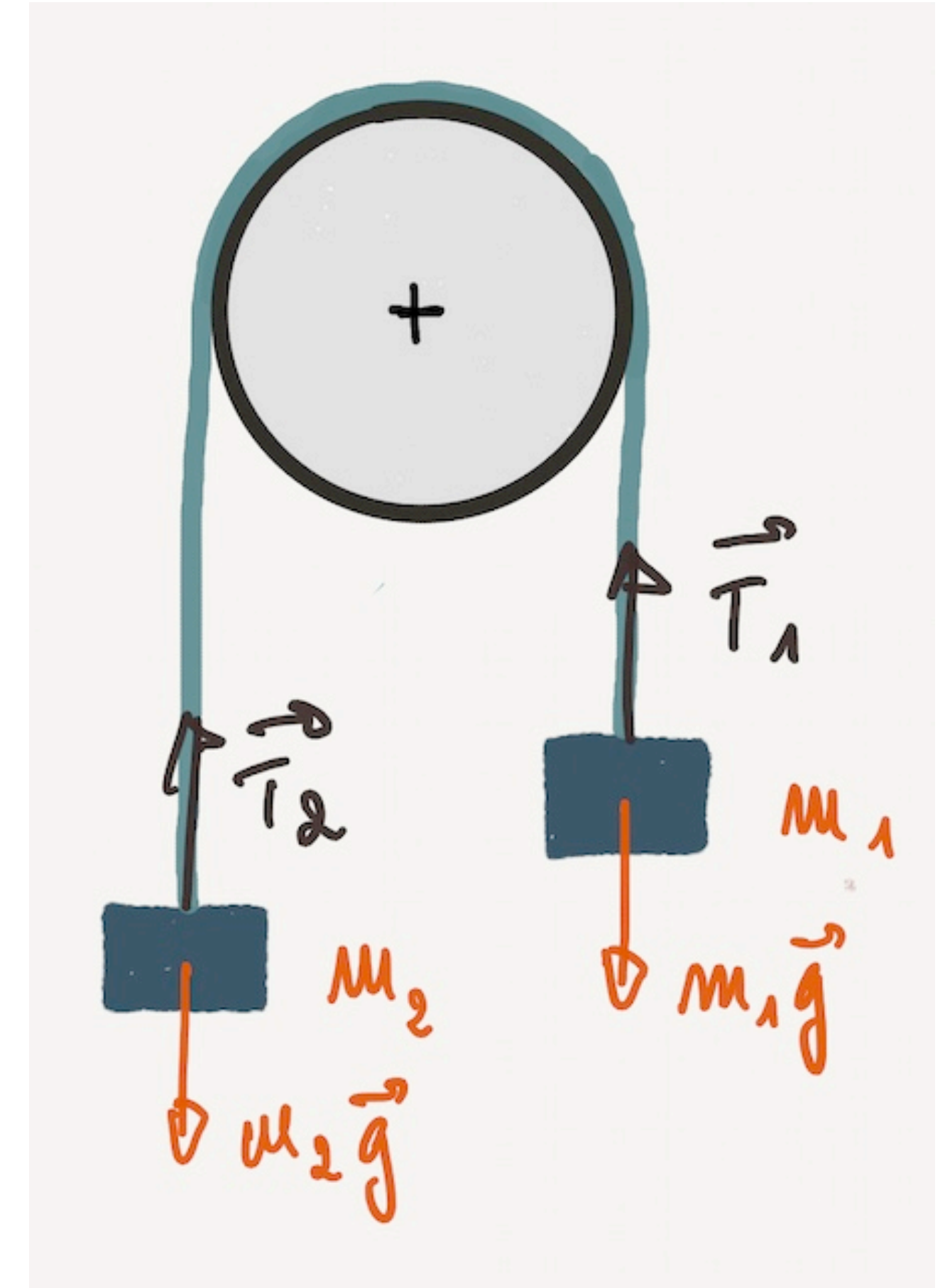

QUIZ: ELEVATOR

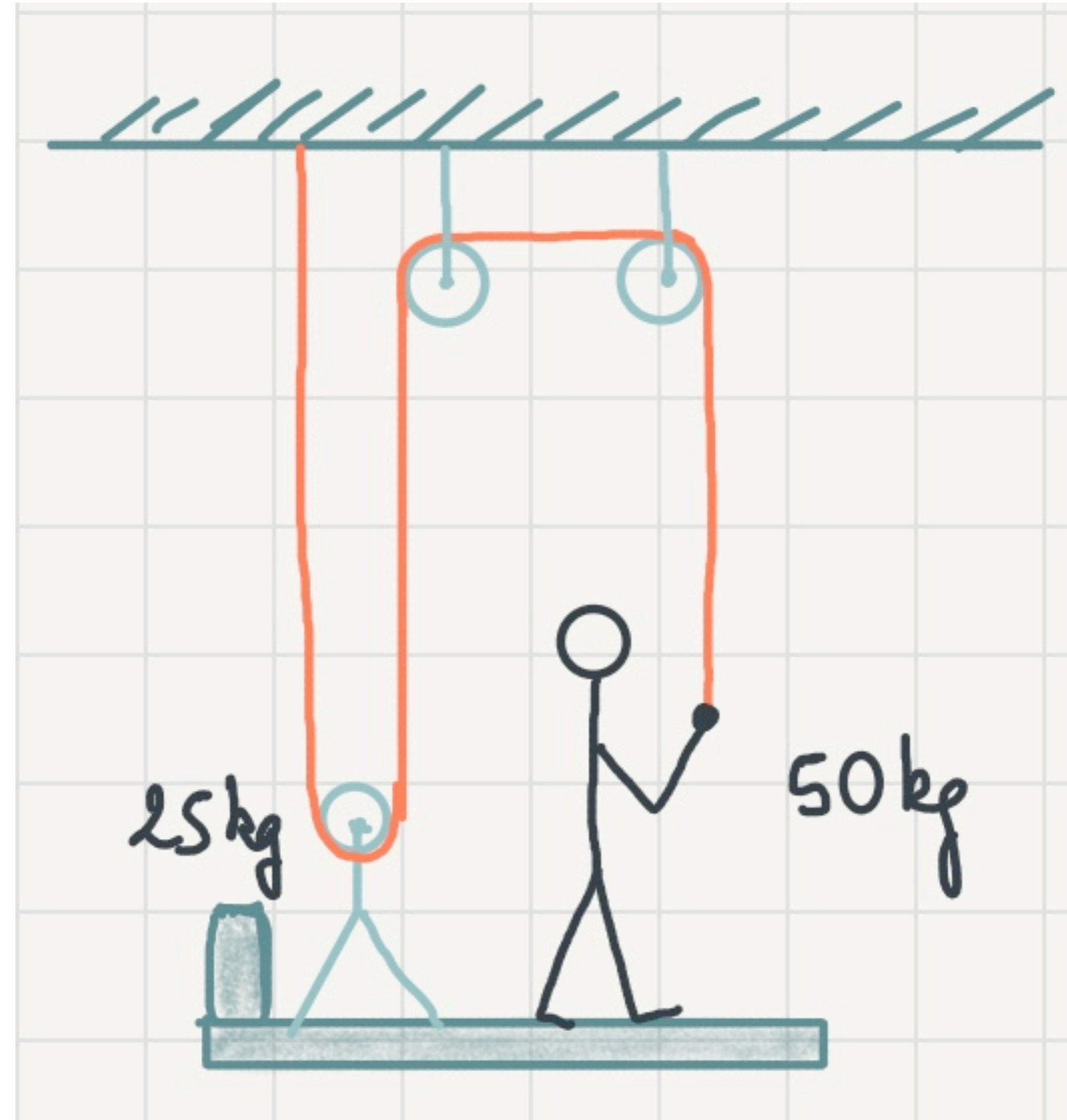

What force does the person (50 kg) need to exert to lift the platform (25 kg) at a constant speed? We take $g = 10\text{m/s}^2$

- 750 N 0%
- 650 N 0%
- 500 N 0%
- 250 N 0%
- 75 N 0%
- 65 N 0%
- 50 N 0%
- 25 N 0%

QUIZ: THREE PULLEYS

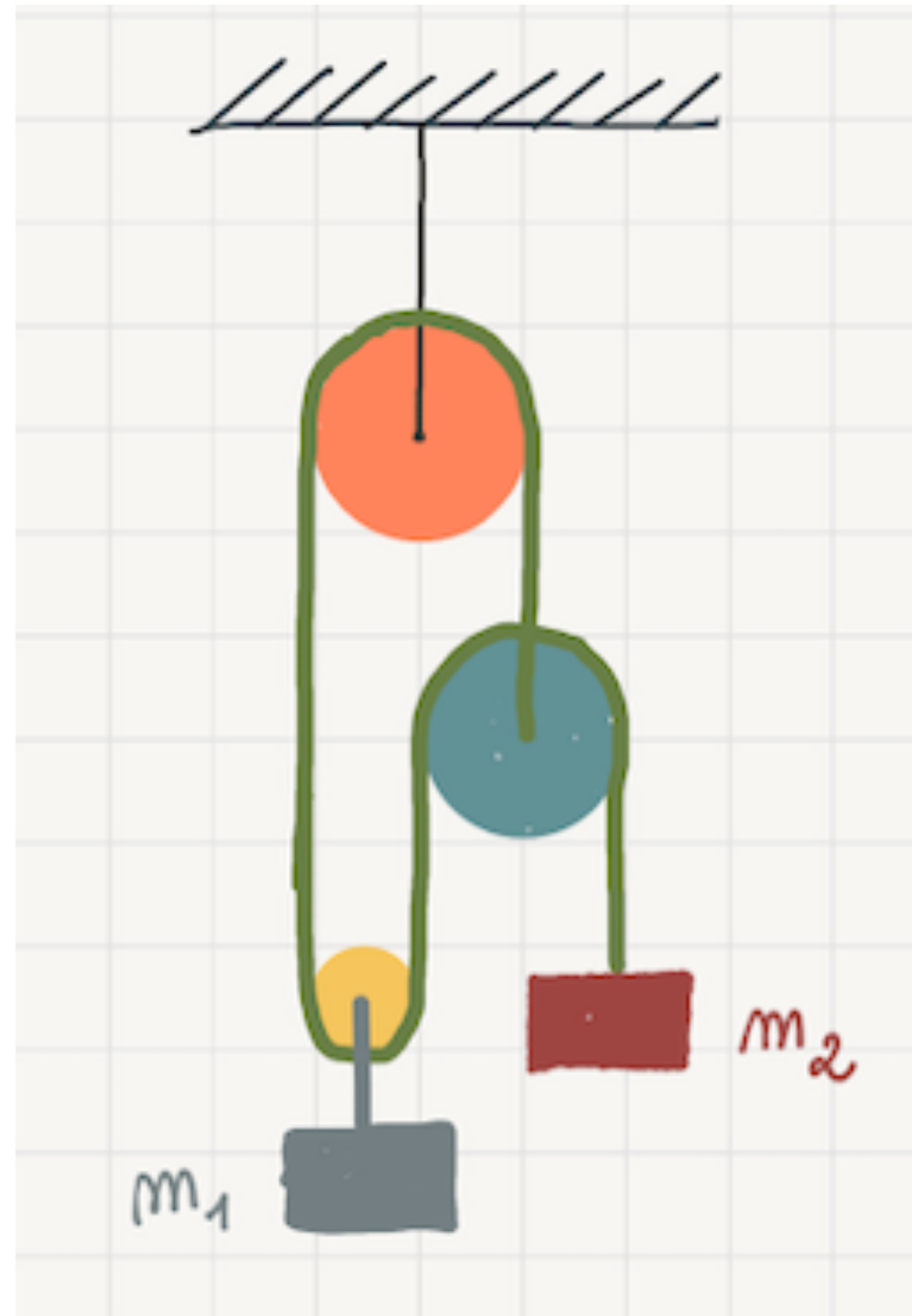

📊 If $m_1 > 0$, what value of m_2 do we need to prevent the system from moving?

- $m_2 = m_1$ 0%
- $m_2 = 2m_1$ 0%
- $m_2 = m_1/2$ 0%
- $m_2 = 3m_1$ 0%
- $m_2 = m_1/3$ 0%
- None will work 0%

EXERCISE

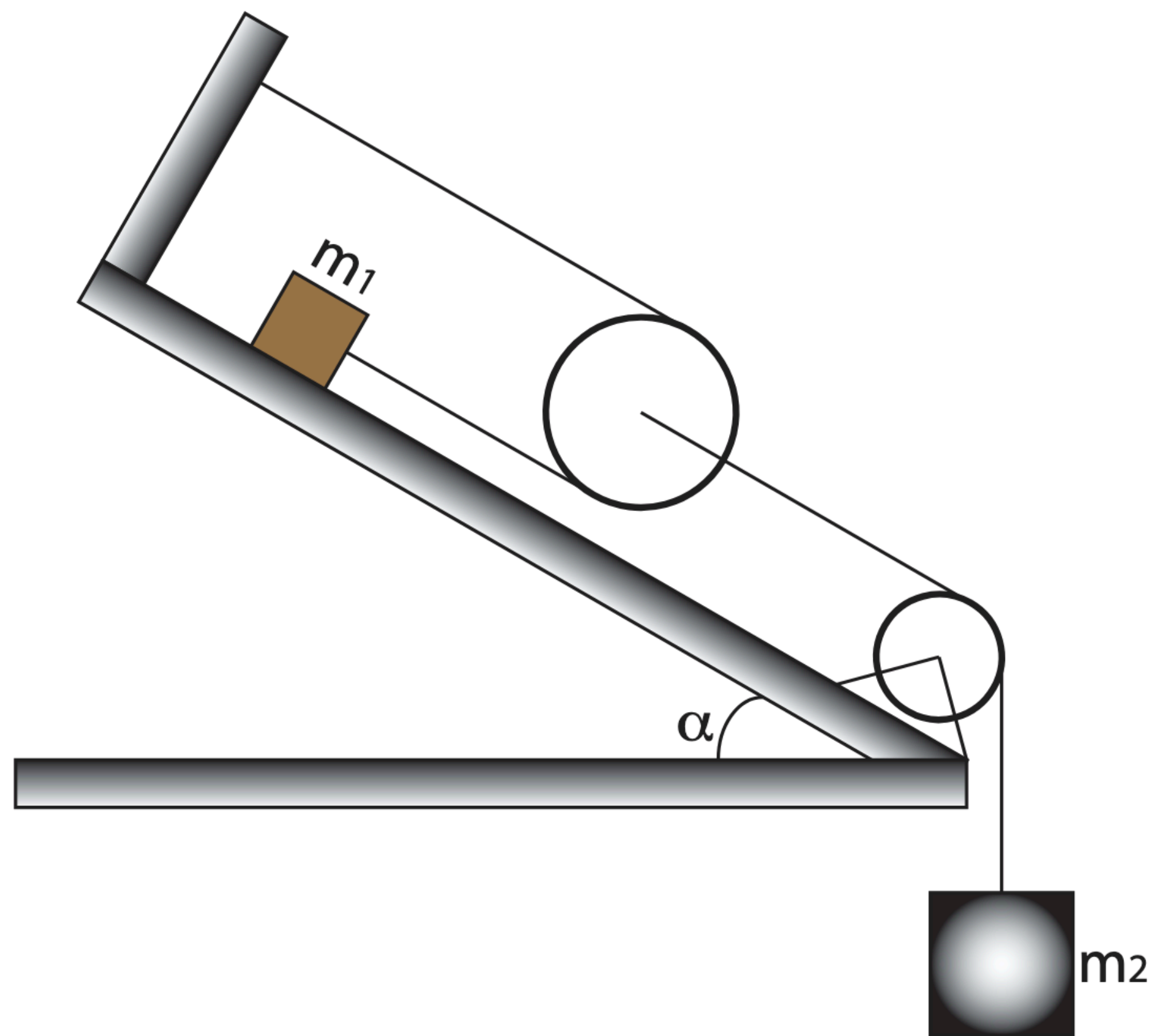

We neglect friction in the pulleys but not friction between the wooden block and the table. The pulleys are massless. The coefficients of static and dynamic friction are μ_s and μ_d , respectively. Answers should be written in terms of the constants of the problem m_1 , m_2 , α , μ_s , and μ_d .

- What is the minimum mass m_2 needed to set the system in motion? Express m_2 in terms of the other constants.
- We now assume that m_2 is equal to twice this minimum value found in part A. Give the acceleration of each of the masses.

EXERCISE

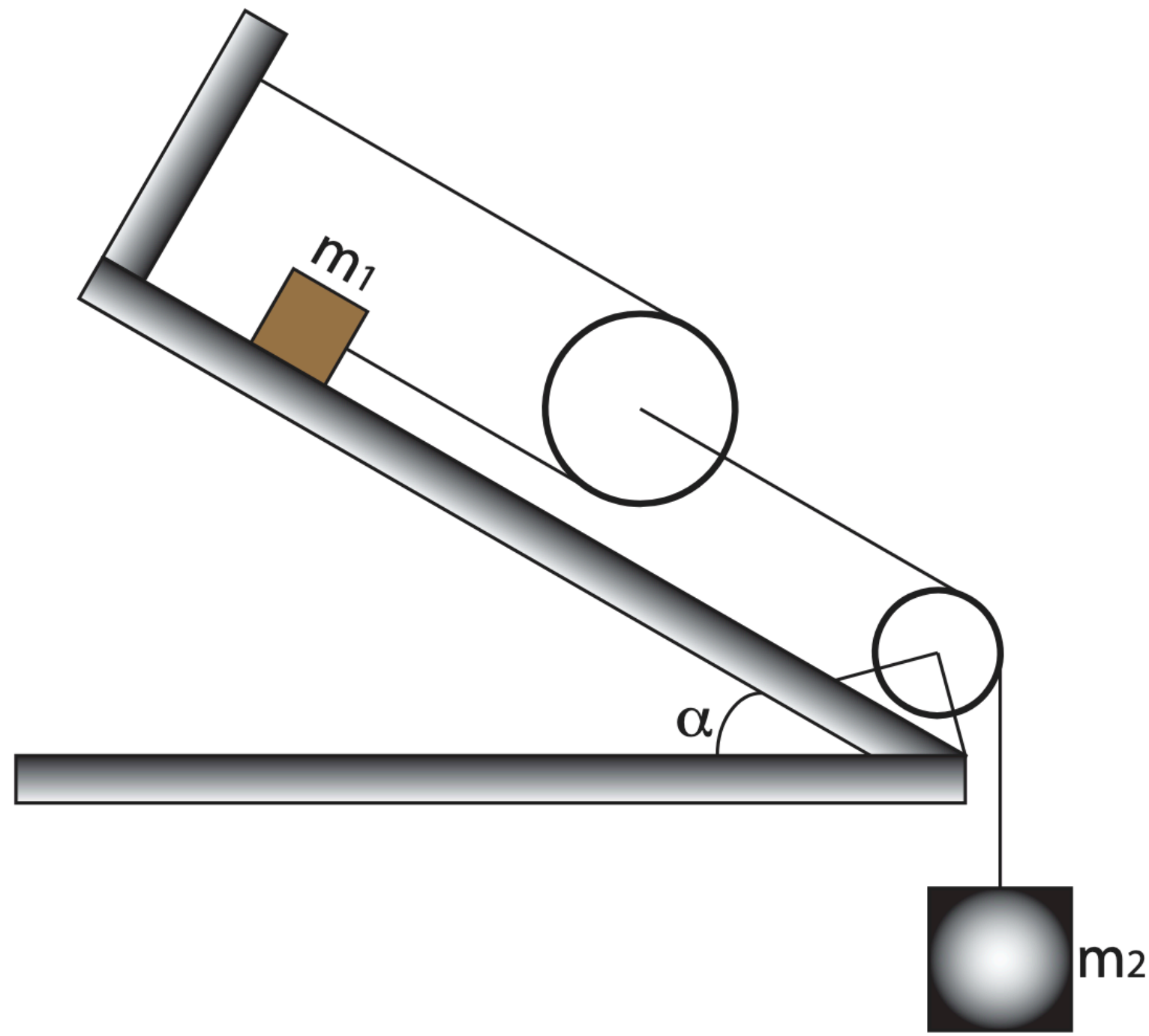

$$2T_1 = T_2$$

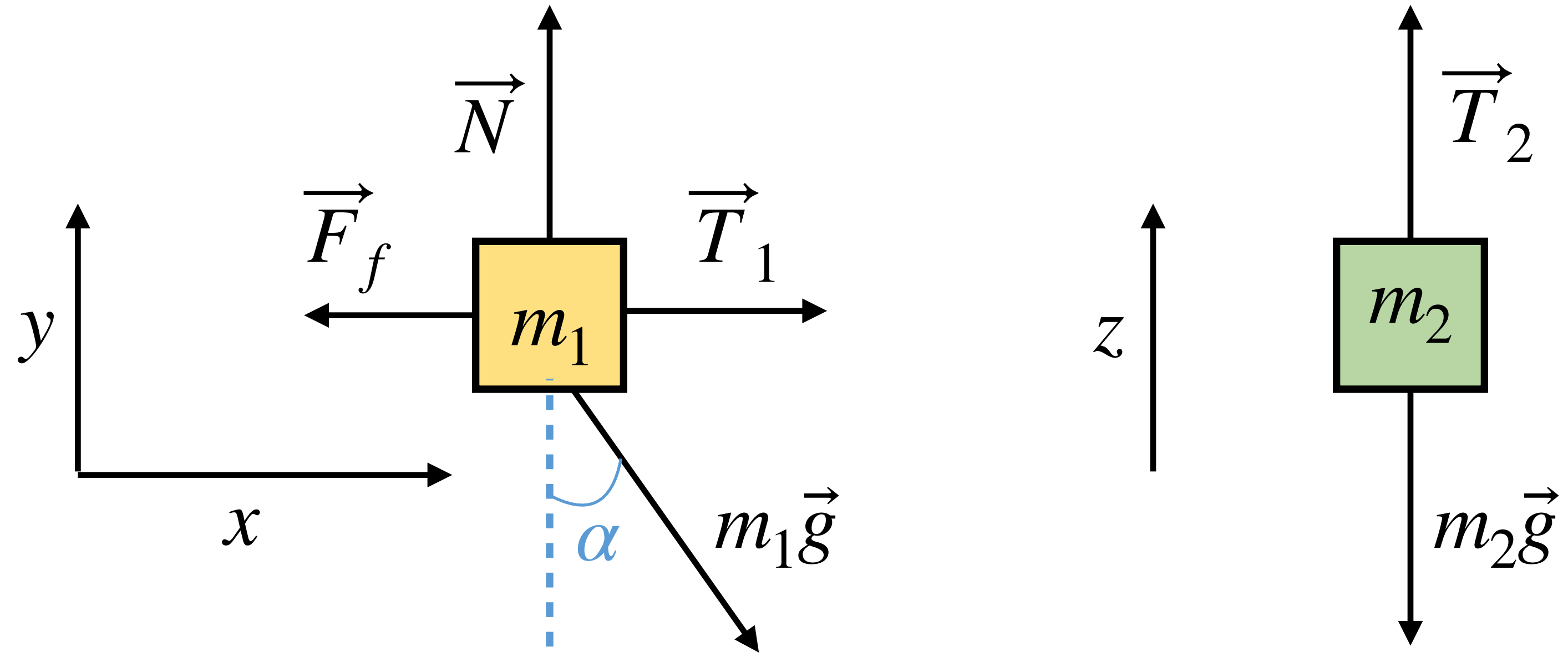

Part A

Answer:

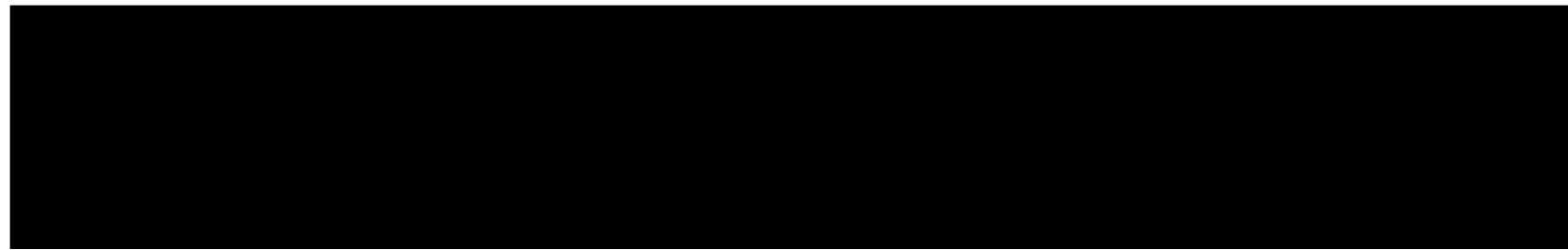

Part B

Hint:

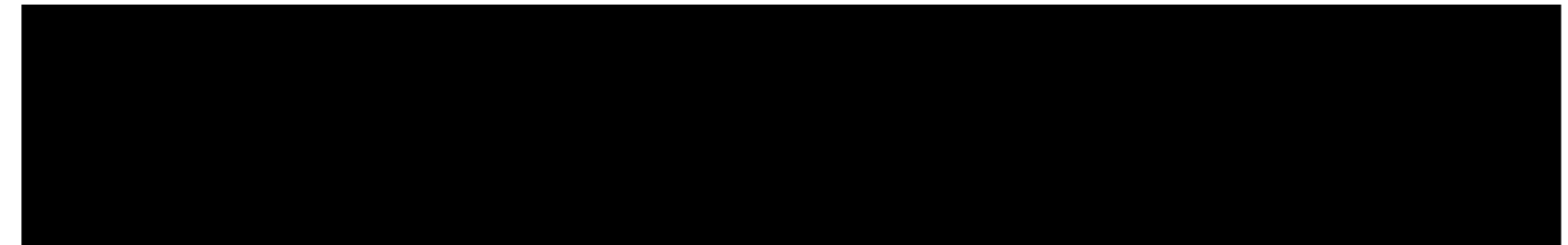

Answer:

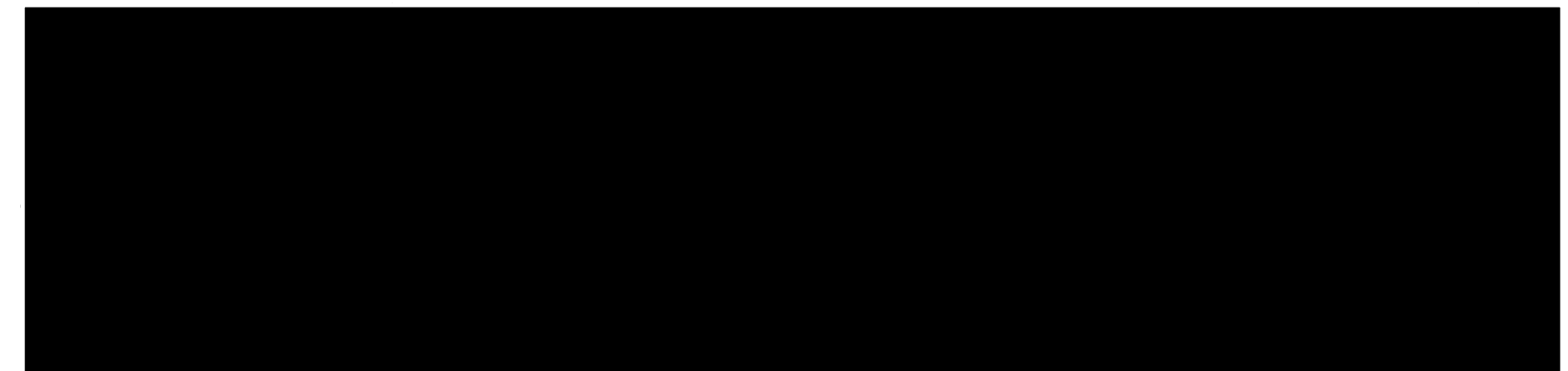

EXERCISE

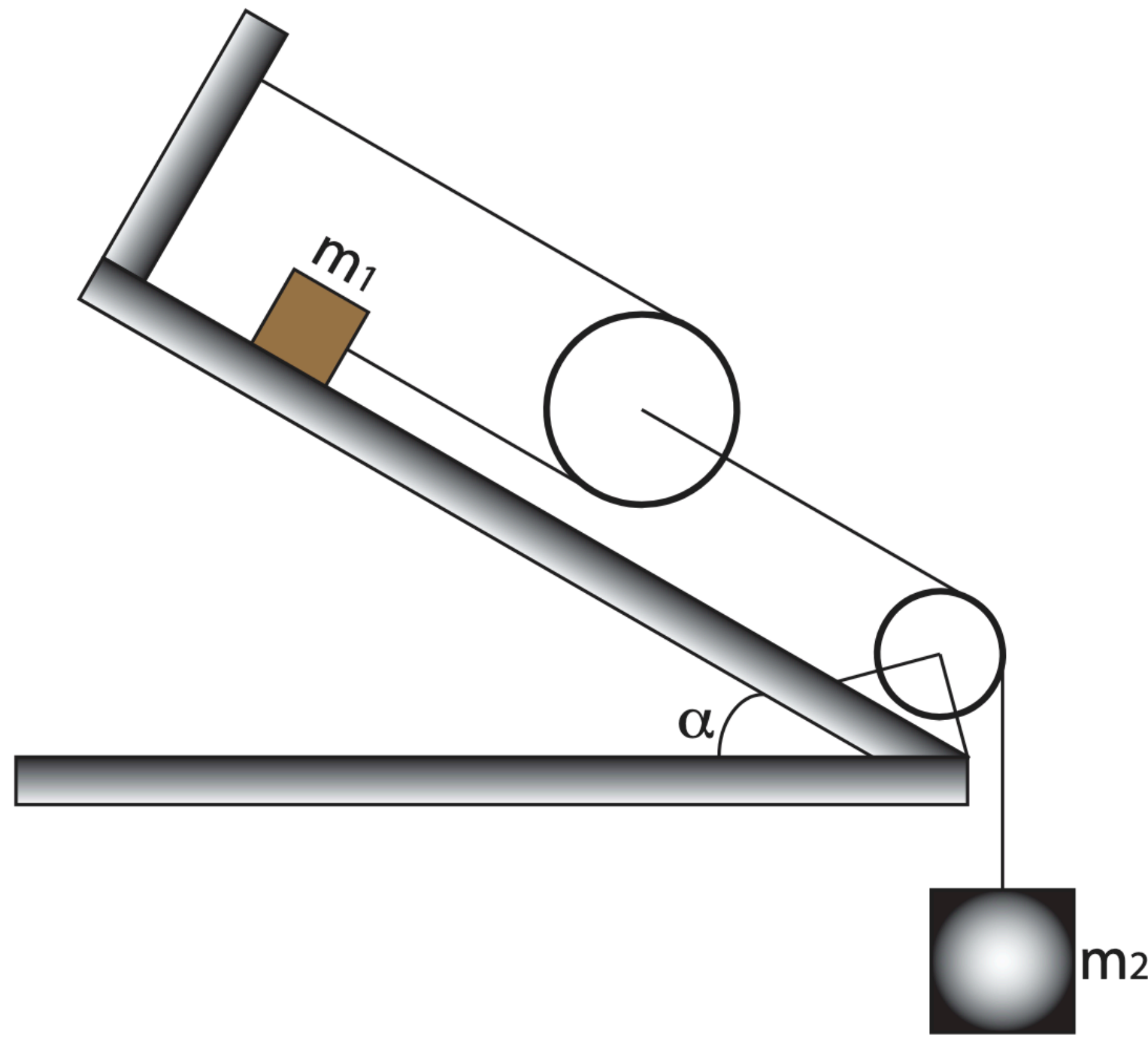

$$2T_1 = T_2$$

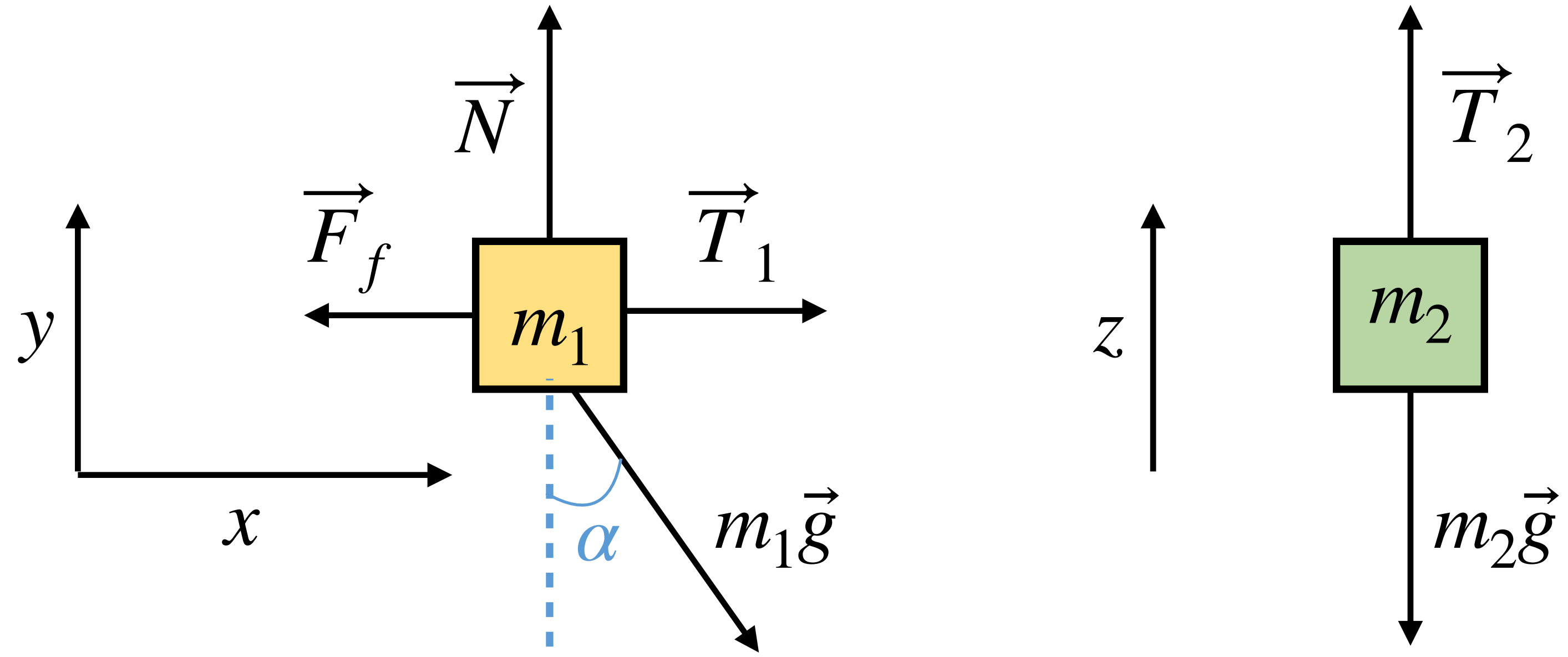

Part A

Answer: $m_2 = 2m_1(\mu_s \cos \alpha - \sin \alpha)$

Part B

Hint:

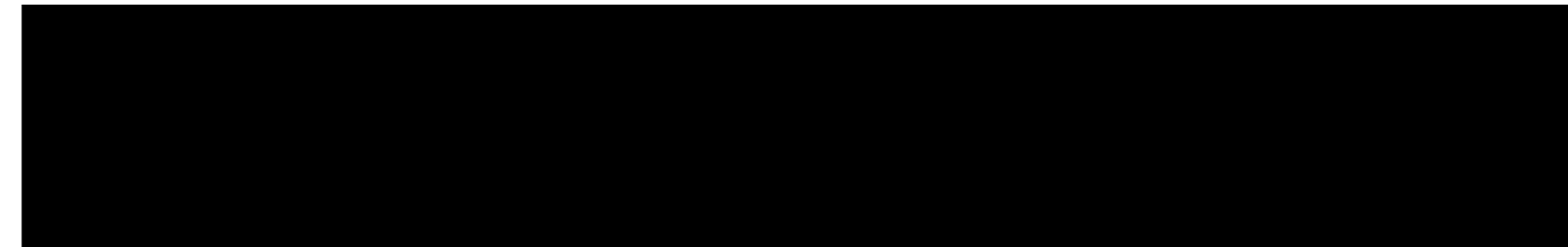

Answer:

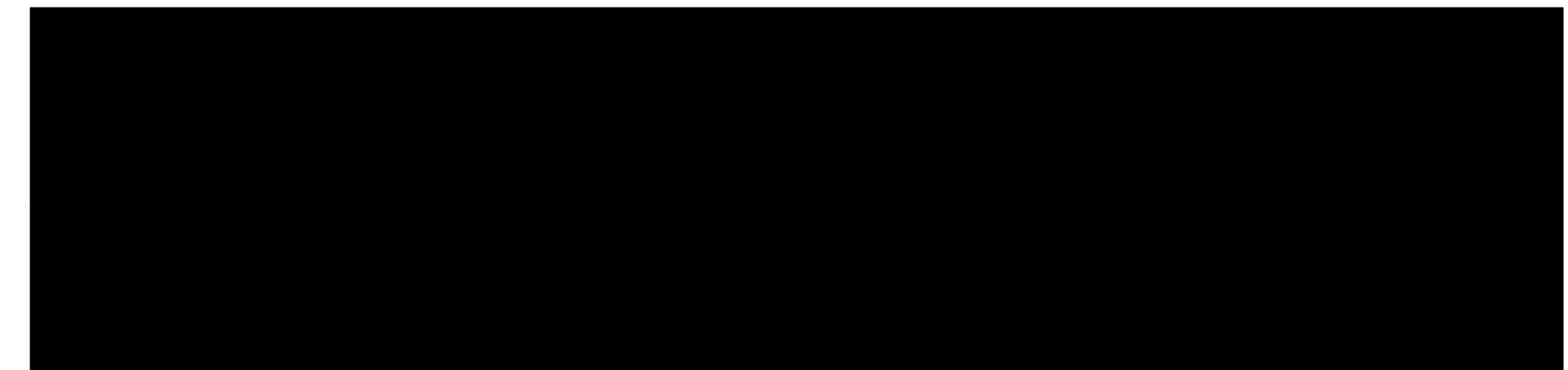

EXERCISE

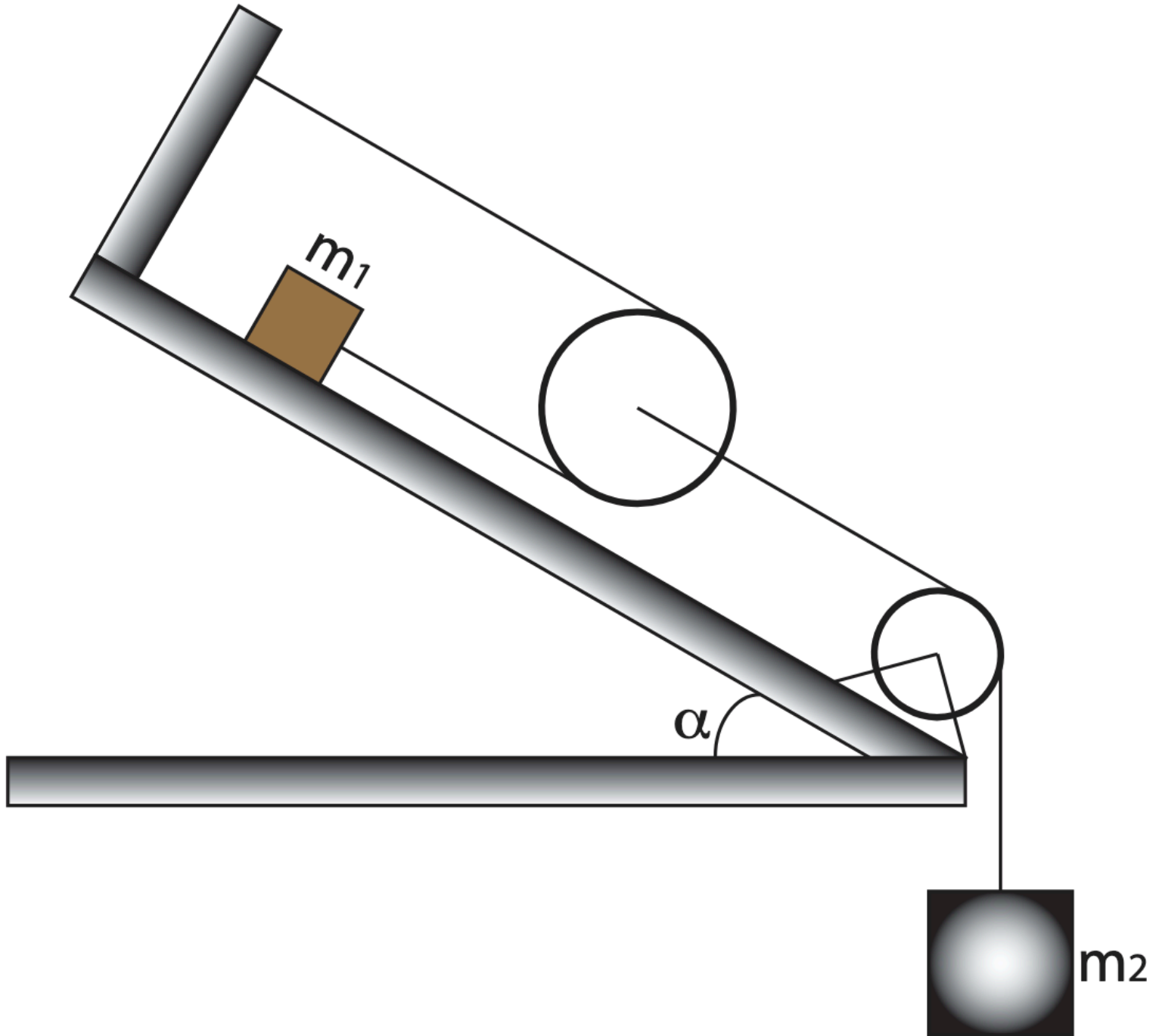

$$2T_1 = T_2$$

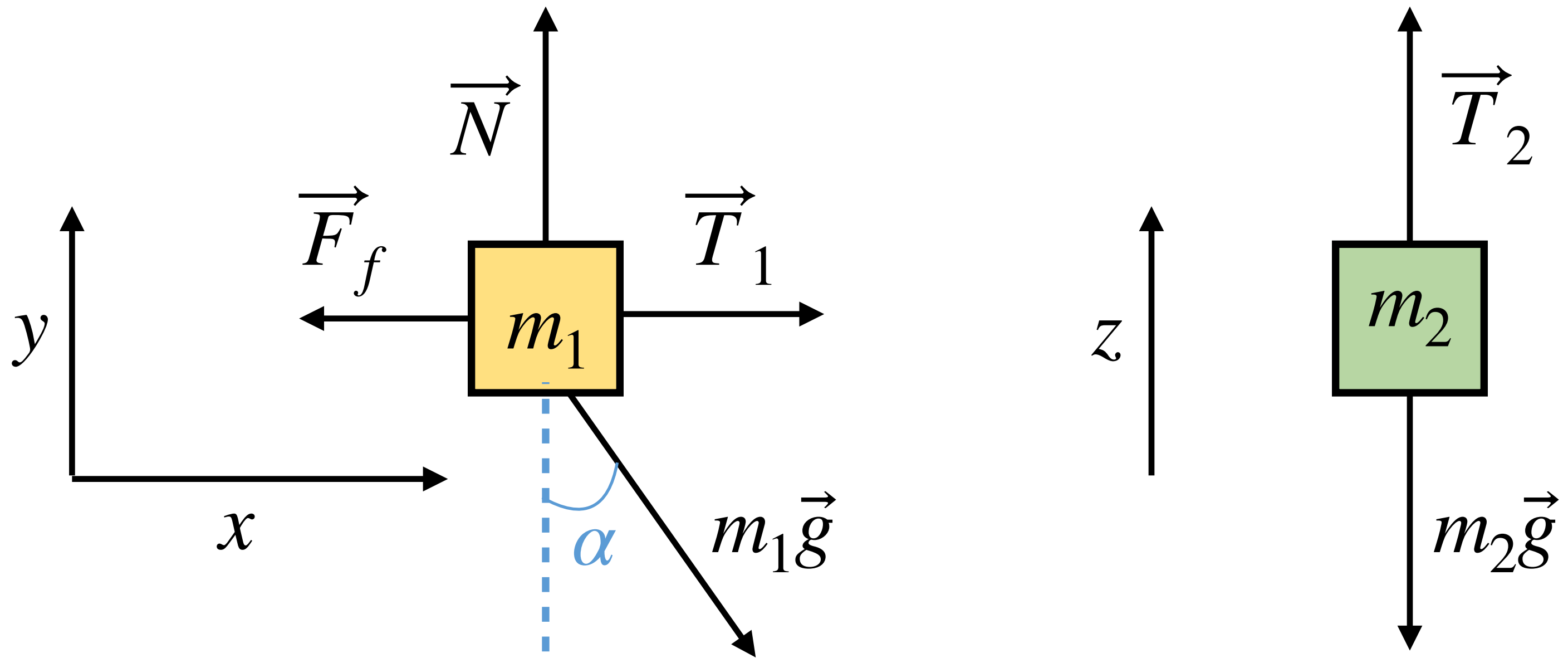

Part A

Answer: $m_2 = 2m_1(\mu_s \cos \alpha - \sin \alpha)$

Part B

Hint: $\ddot{x}_1 = -2\ddot{z}_2$

Answer:

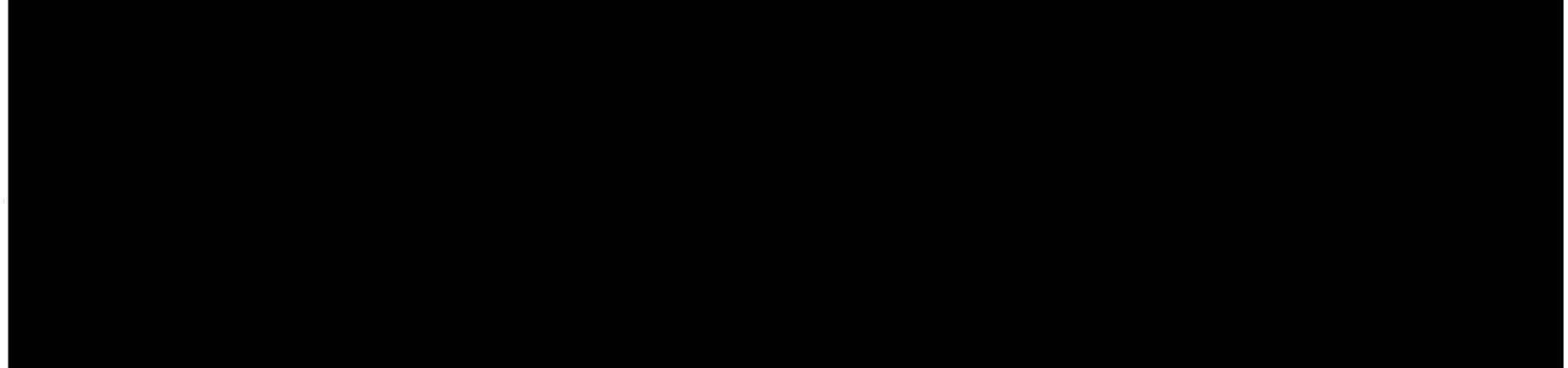

EXERCISE

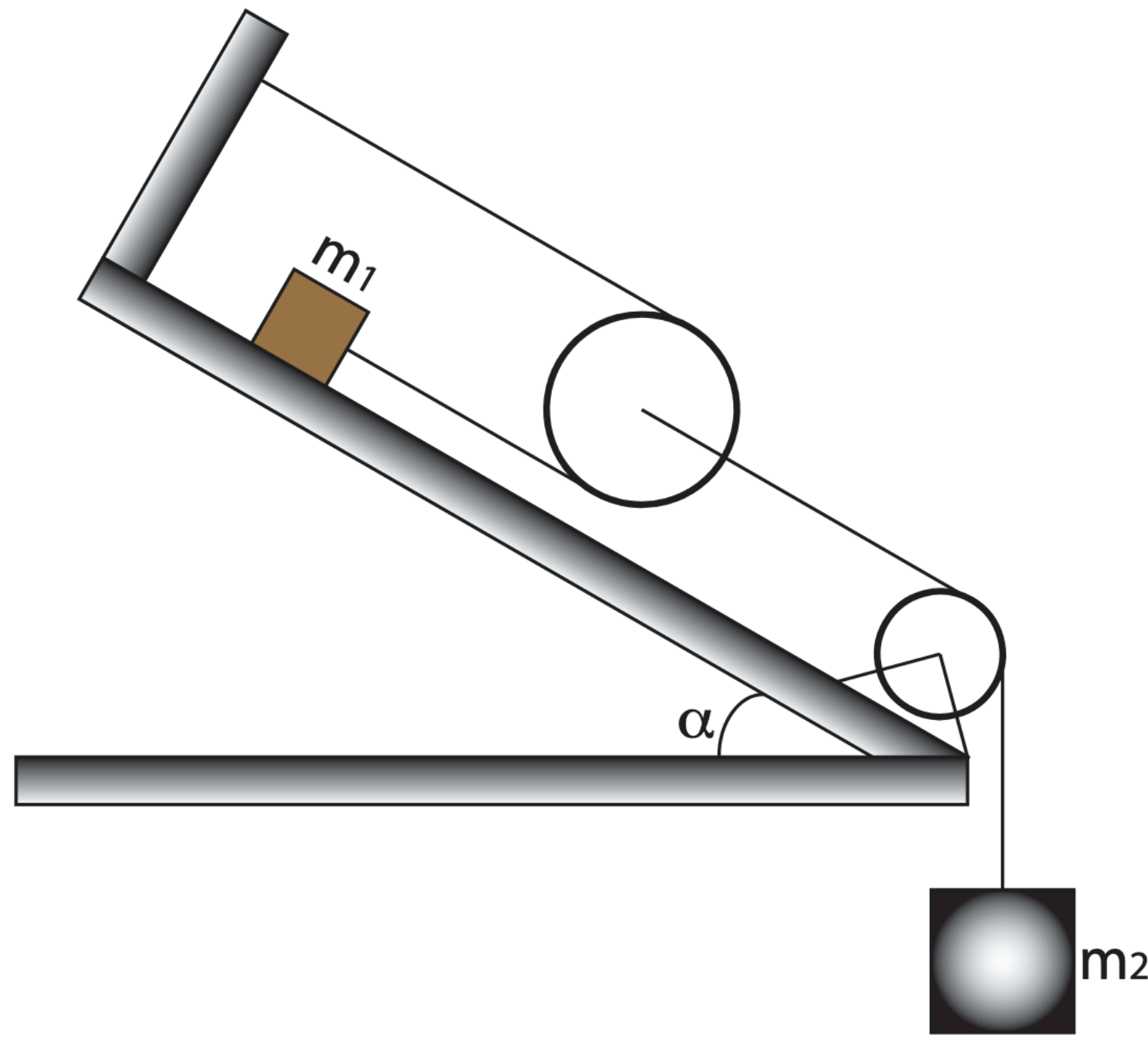

$$2T_1 = T_2$$

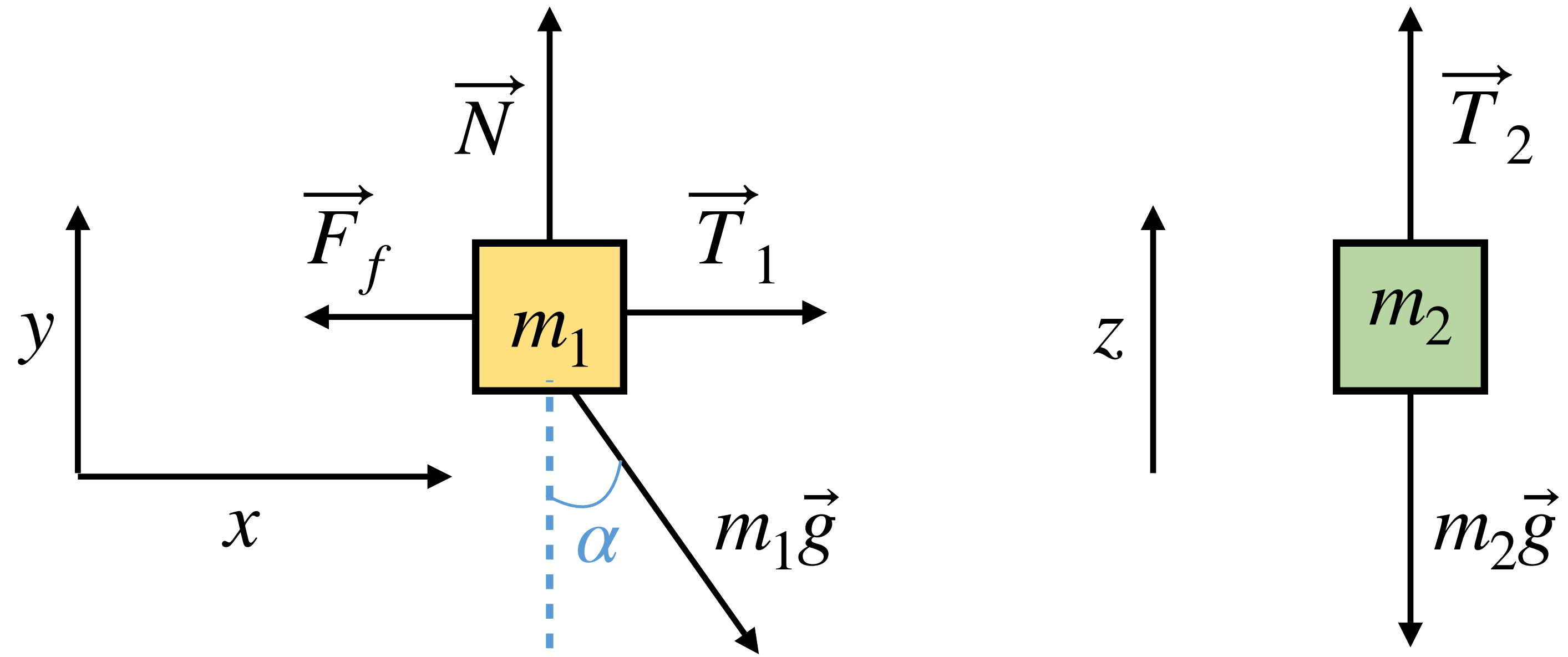

Part A

Answer: $m_2 = 2m_1(\mu_s \cos \alpha - \sin \alpha)$

Part B

Hint: $\ddot{x}_1 = -2\ddot{z}_2$

Answer:
$$\ddot{x}_1 = \frac{g((2\mu_s - \mu_d)\cos \alpha - \sin \alpha)}{1 + \mu_s \cos \alpha - \sin \alpha}$$