

Scanning Electron Microscopy Techniques

MSE-636

How the SEM works?

What type of information we can obtain from looking at the SEM images?

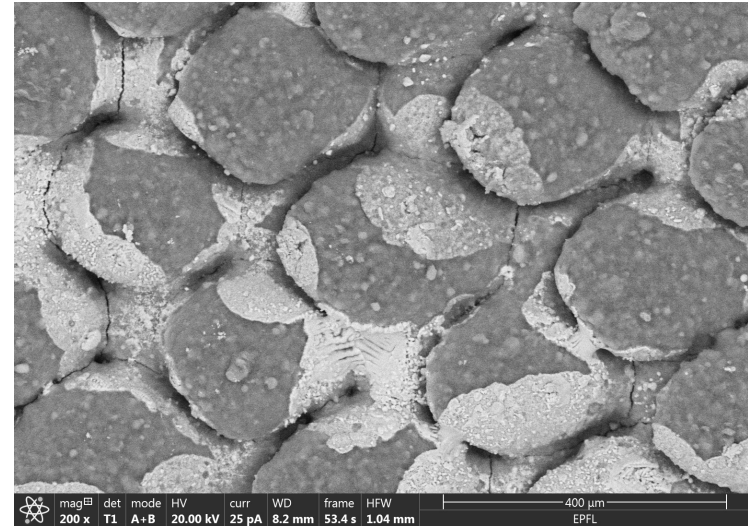
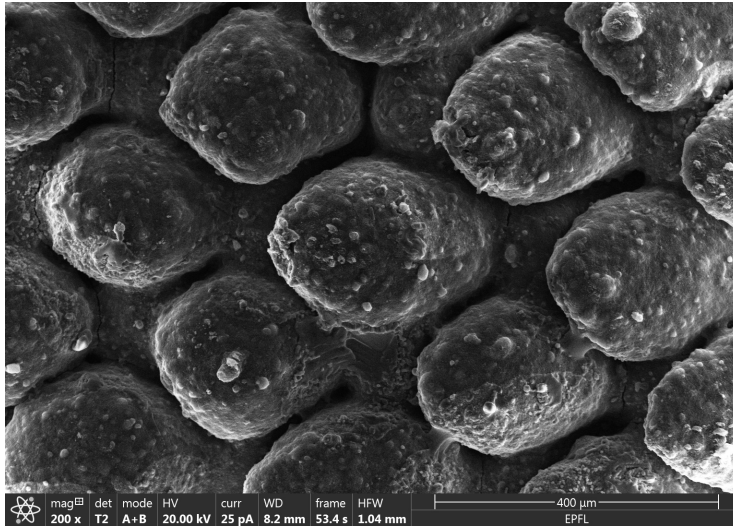

Why these two SEM images from identical locations are different?

Learning Outcomes

	mag 	det	mode	HV	curr	WD	frame	HFV	400 μ m	
	200 x	T2	A+B	20.00 kV	25 pA	8.2 mm	53.4 s	1.04 mm	EPFL	

What can this information tell us?

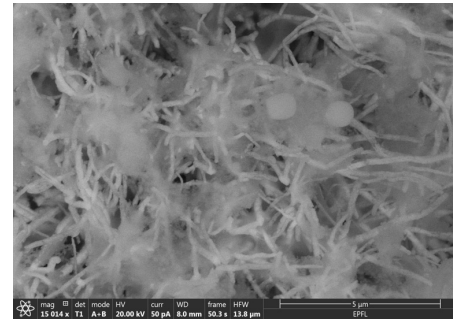
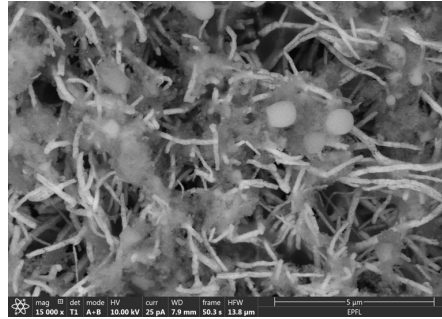
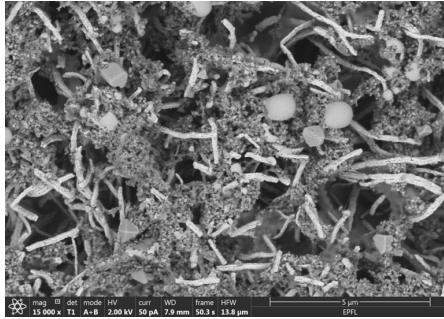

Cu grid treated with KOH

How can we use it to interpret the images?

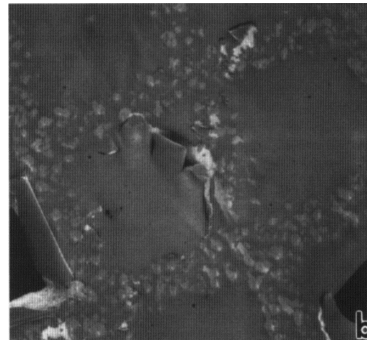
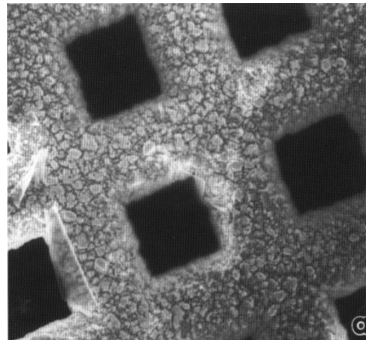

Carbon supported TEM grid

And how do we tune the microscope parameters to obtain the specific information we are seeking?

- **Introduction to electron microscopy** (by E. Oveisi)
 - Resolution and why fast electrons**
 - Electron matter interaction**
 - **SEM setup**
 - Electron sources**
 - Lenses**
 - Vacuum system**
 - Detection system**
 - **Imagining with SEM**
 - Operation, Signals**
 - Contrast mechanism**
 - Interpretation of images, Challenges**
- Related techniques** (By M. Cantoni)
- Advanced and high-resolution SEM**
- **Chemical analysis and Monte-Carlo simulations**
 - **Focused ion beam**

A **Scanning Electron Microscope (SEM)** is an instrument for **observing** and **analyzing** the surface structure of a bulk sample using a finely focused probe that scans the sample in raster.

1st electron microscope (TEM) in 1933 by Ernst Ruska (1986 Nobel Prize in Physics)

The first true SEM was described and developed in 1942 by Zworykin

1st commercial SEM in 1965 by the Cambridge Scientific Instruments Mark I “Stereoscan”

Primary applications:

- Surface topography and morphology; in life and materials sciences
- Composition analysis (e.g. EDX or WDX)
- Crystallography (e.g. EBSD)
- Optical and electronic properties (e.g. Cathodoluminescence), and more ...

SEM can achieve 1-5 nm **resolution**, depending on the instrument and the imaging condition being used.



Teneo, TFS



Coloured image of fruit fly mutant

<https://www.sciencephoto.com>

The resolution of an optical microscope is defined as the minimum distance between two point sources (e.g. objects) such that their presence can be distinguished in the image.

Abbe's definition of maximum resolution of an optical system states that the smallest feature resolved is limited by diffraction.

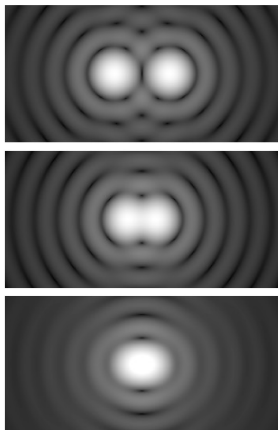

Airy Diffraction Disks

SEM techniques

Visible light: $\lambda \approx 300-700$ nm \rightarrow resolution around half of the λ

Electrons: $\lambda = h \cdot c / E$: Wave-particle duality

@ 200 keV: $\lambda = 0.025$ Å \ll interatomic spacing*

$$r = \frac{1.22\lambda}{2\sin\theta} \approx \frac{0.61\lambda}{\theta}$$

For the 30 keV SEM around < 1 nm resolution possible

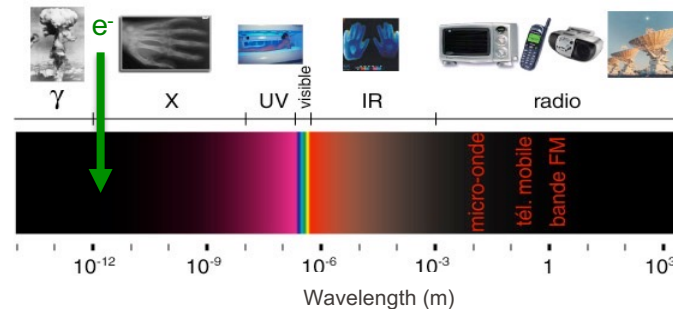

*Aberrations & instabilities \rightarrow actual resolution around 25-50 λ , but atomic/sub-Å resolution possible in TEM

Why fast electrons?

Light microscope

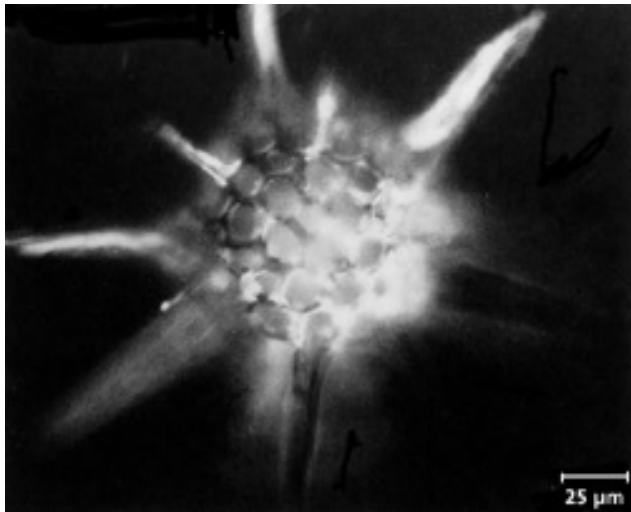

SEM

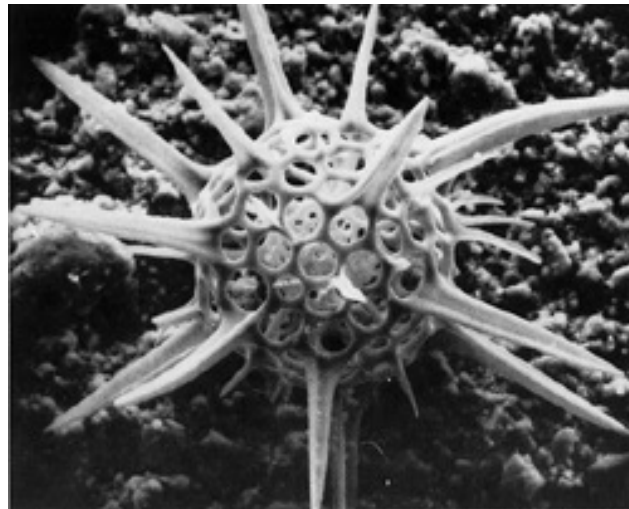

Radiolarian

Compared to light microscopy, SEM offers:

- Better resolution; shorter wavelength of electrons
- Better depth of field (i.e. how much of depth is sharp = in focus); lower convergence angle of the electron beam, in the order of mrad

Why fast electrons?

	Advantageous	Disadvantageous
Visible light	Not very damaging Easily focused Eye detector	Long wavelengths (400 nm)
X-rays	Small wavelength (Angstrom) Good penetration	Hard to focus Damage sample
Neutrons	Low sample damage Small wavelength (pm)	How to produce? How to focus?
Electrons	Small wavelength (pm) Can be focused to a sub-Å size probe Wave-particle duality	Damage sample Poor penetration (< x00 nm)

High energy electrons have a short wavelength
 Easy to produce high brightness electron beams
 Easy to manipulate: focused
Interact strongly with matter

Electron microscopes are used not only for obtaining good resolution images but also:

- **can be used as a diffractometer (EBSD-SEM and TEM)**
- **for chemical analyses (EDX, WDX and EELS_{in TEM})**
- **for imaging/measuring strain-, magnetic-, electric-field in the sample (TEM specific)**
- **for imaging optoelectronic properties (cathodoluminescence), etc.**

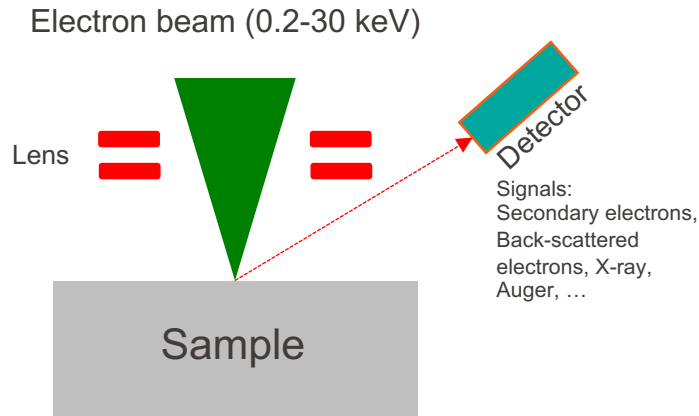

Electrons are accelerated to high energies and will go through the lens system

Lens system focuses and scans the probe on sample

Electrons interact with the sample and different signals are generated

Various detectors surrounding sample collect radiated signals for each scan point to form an image

→ Image is formed point by point

How is an SEM image generated?

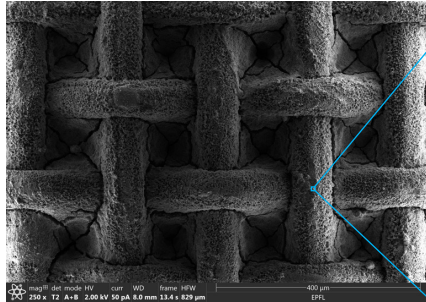

1534x1024 Pixels
Frame time 13.4 Sec

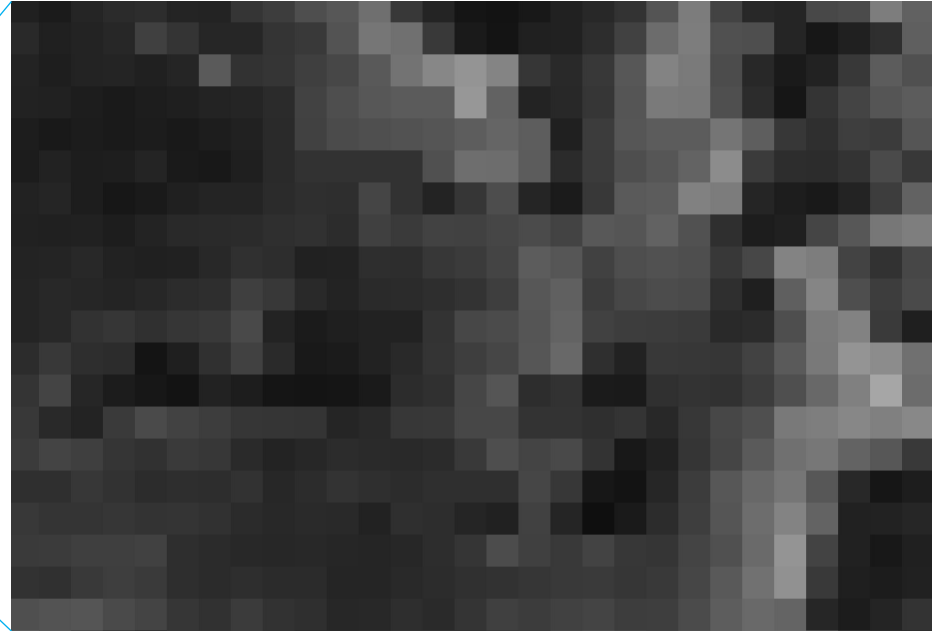

SEM image is made of pixels of different grey level

How is an SEM image generated?

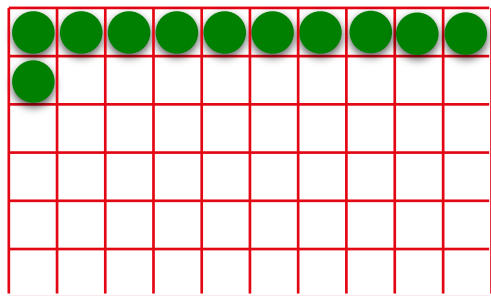

Beam locations on the specimen

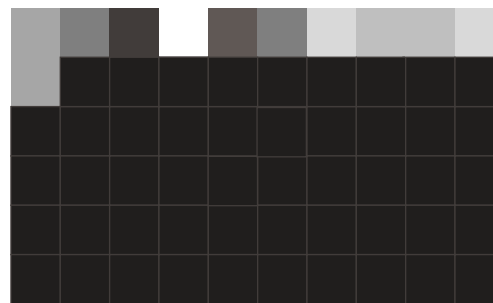

Area scanned on the screen

Information transfer $f(x,y,S)$

- Image formed step by step by the sequential scanning of the sample with the electron probe (using pair of deflector or scan coils, controlled by the scan generator)
- Monitor and scanning coils are synchronized
- Intensity of each pixel is proportional to signal received (collected SE/BSE electrons)
- When changing the magnification, we just change the raster size (no change in optics)

Magnification = Image size (e.g. display) / Raster size on the specimen

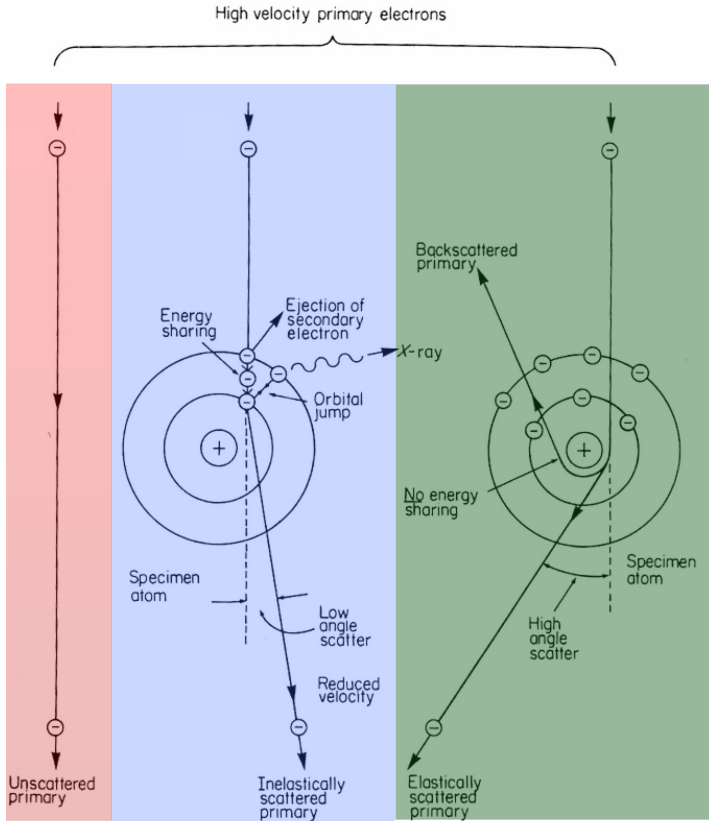

Inelastic events: The result is a **transfer of beam energy** to the specimen atom (**energy loss**) and a potential expulsion of an electron from that atom as a **secondary electron (SE)**.

If the vacancy due to the creation of a secondary electron is filled from a higher level orbital, an X-Ray or Auger characteristic of that energy transition is produced.

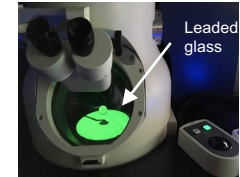

That's why TEMs are shielded!

Characteristic X-rays elemental map

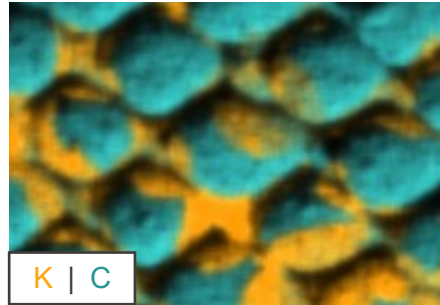

Chemical composition

Secondary electron SEM image

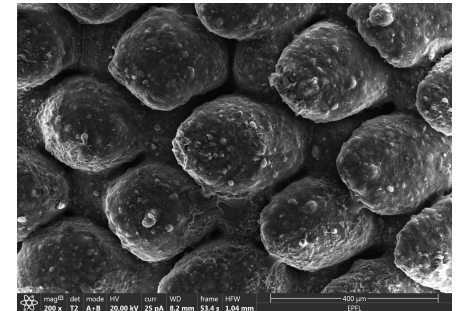

Topography

Cu grid treated with KOH

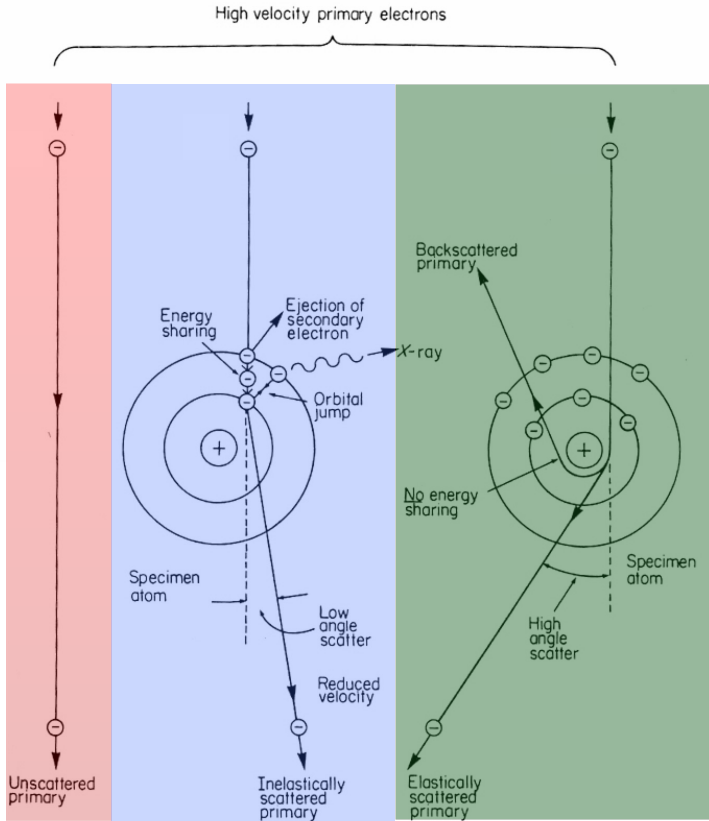

Elastic events occur when a beam electron interacts with the electric field of the nucleus or electron cloud of a specimen atom (Coulomb forces), resulting in a change in the direction of the beam electron **without a significant change in the energy** of the beam electron ($< 1 \text{ eV}$).

Coulombic interaction within the electron cloud, Low-angle scattering
 Coulombic attraction by the nucleus, Higher-angle scattering

Mass contrast backscattered SEM image

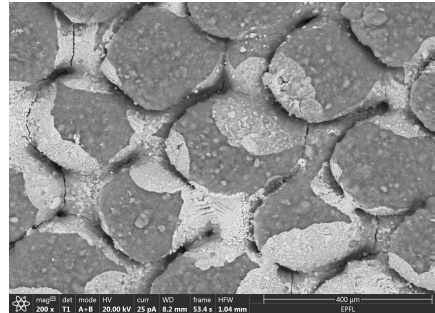

Larger nucleus → More backscattering

Characteristic X-rays elemental map

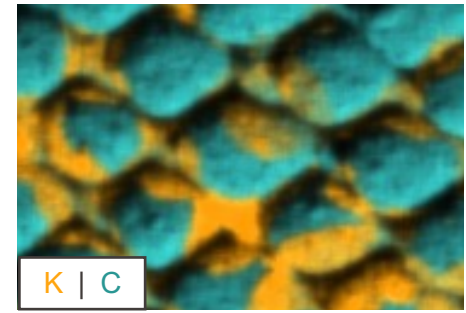

Chemical composition

How is an SEM image generated?

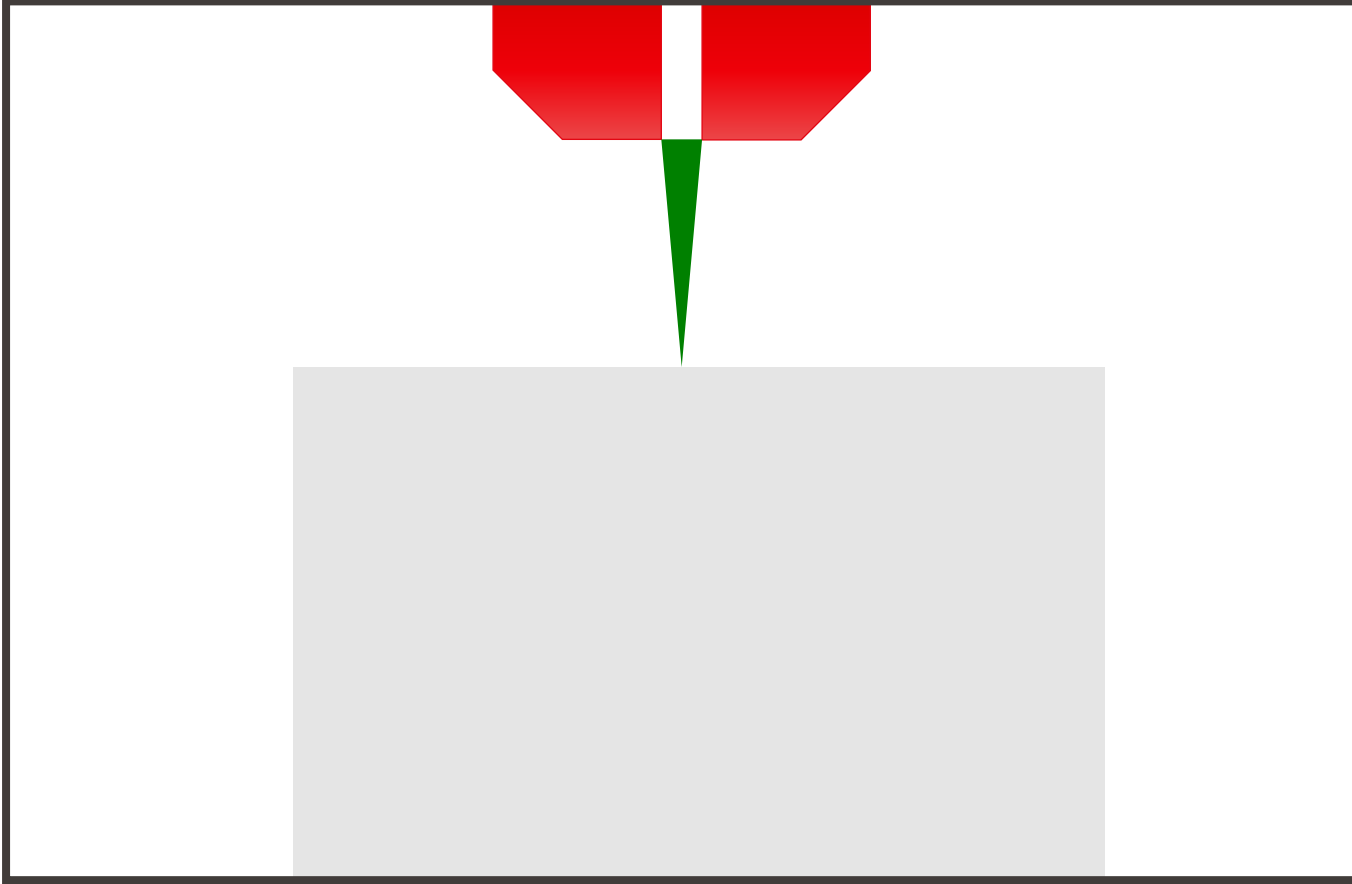

How is an SEM image generated?

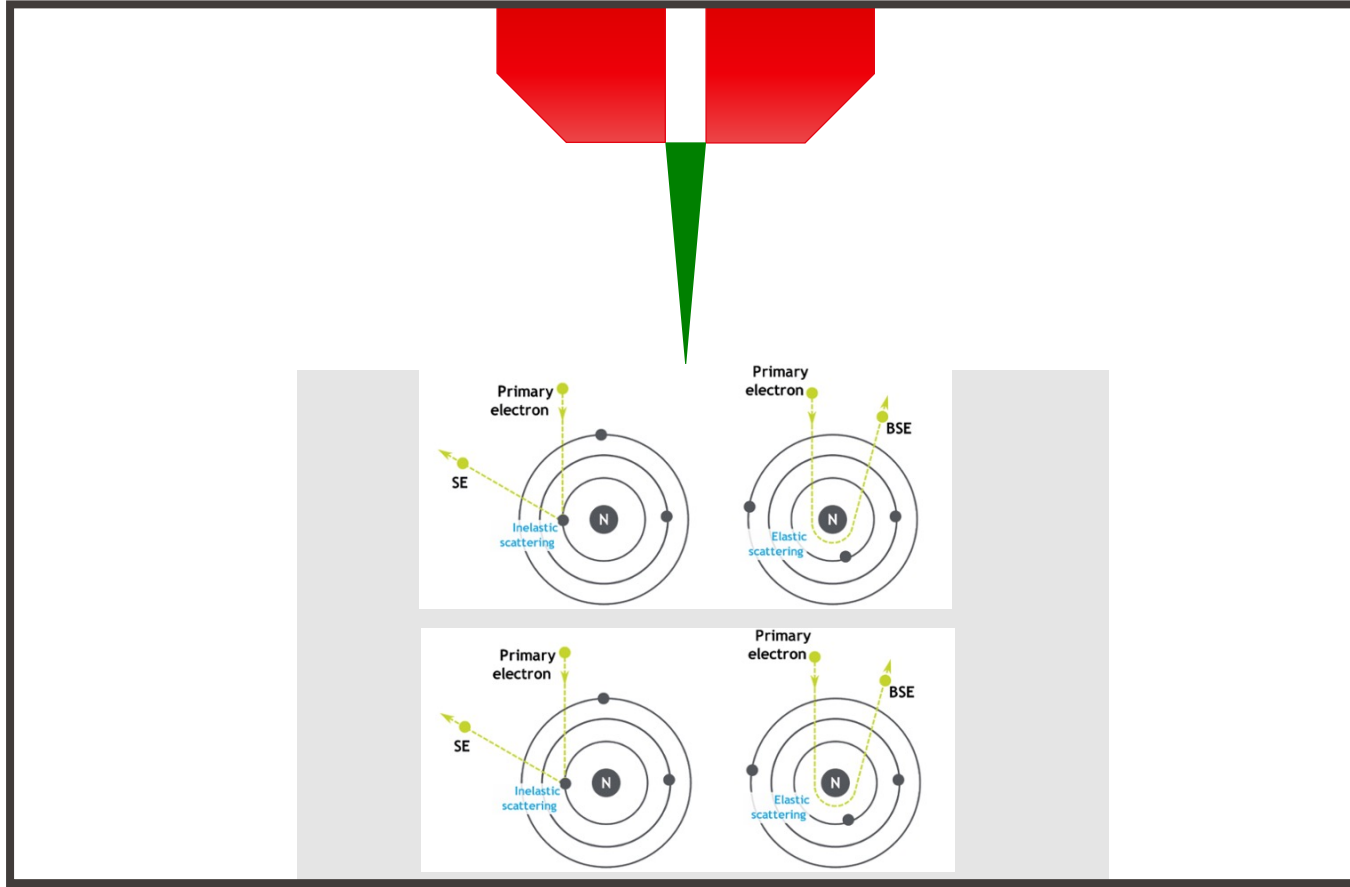

How is an SEM image generated?

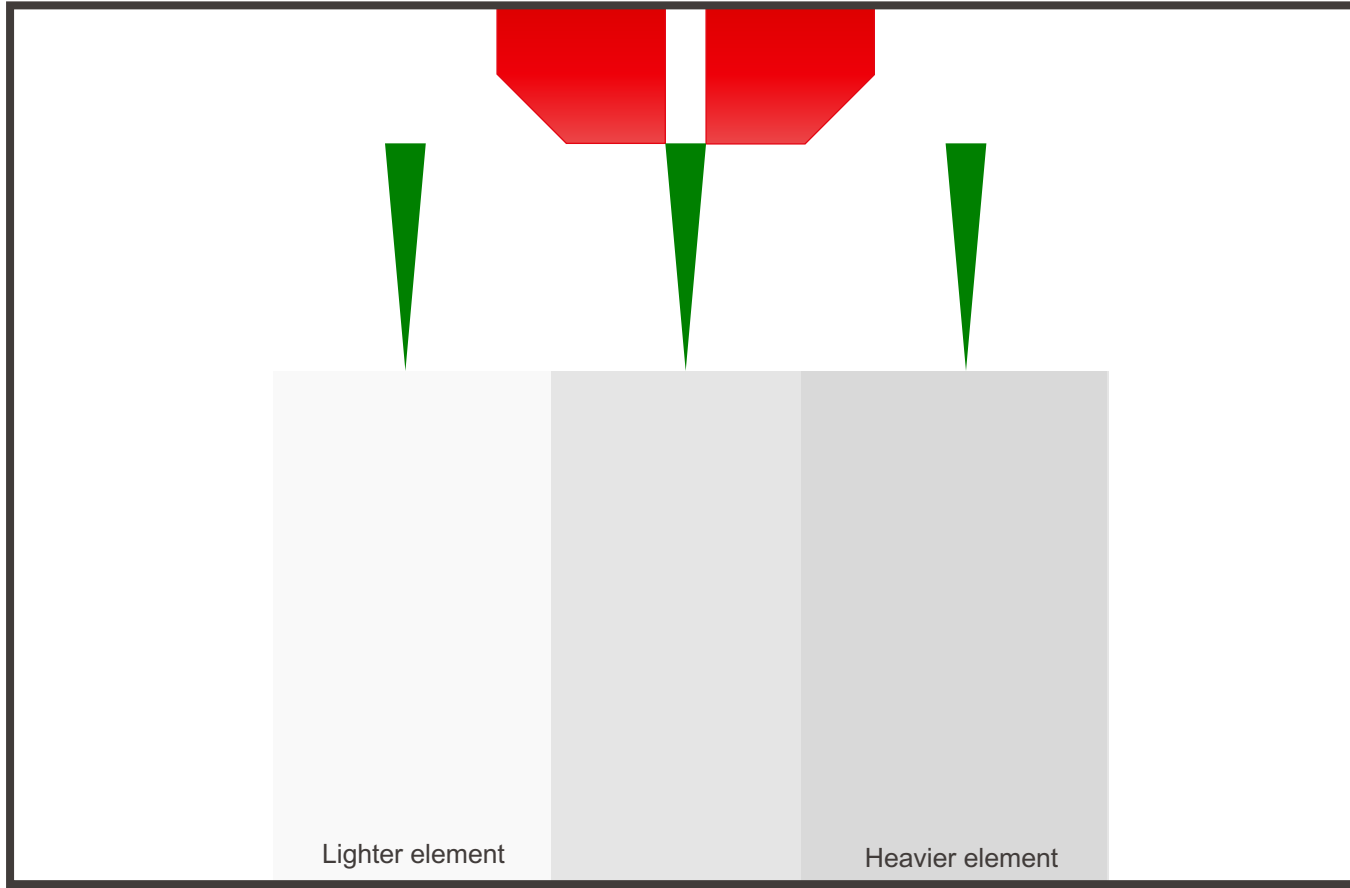

How is an SEM image generated?

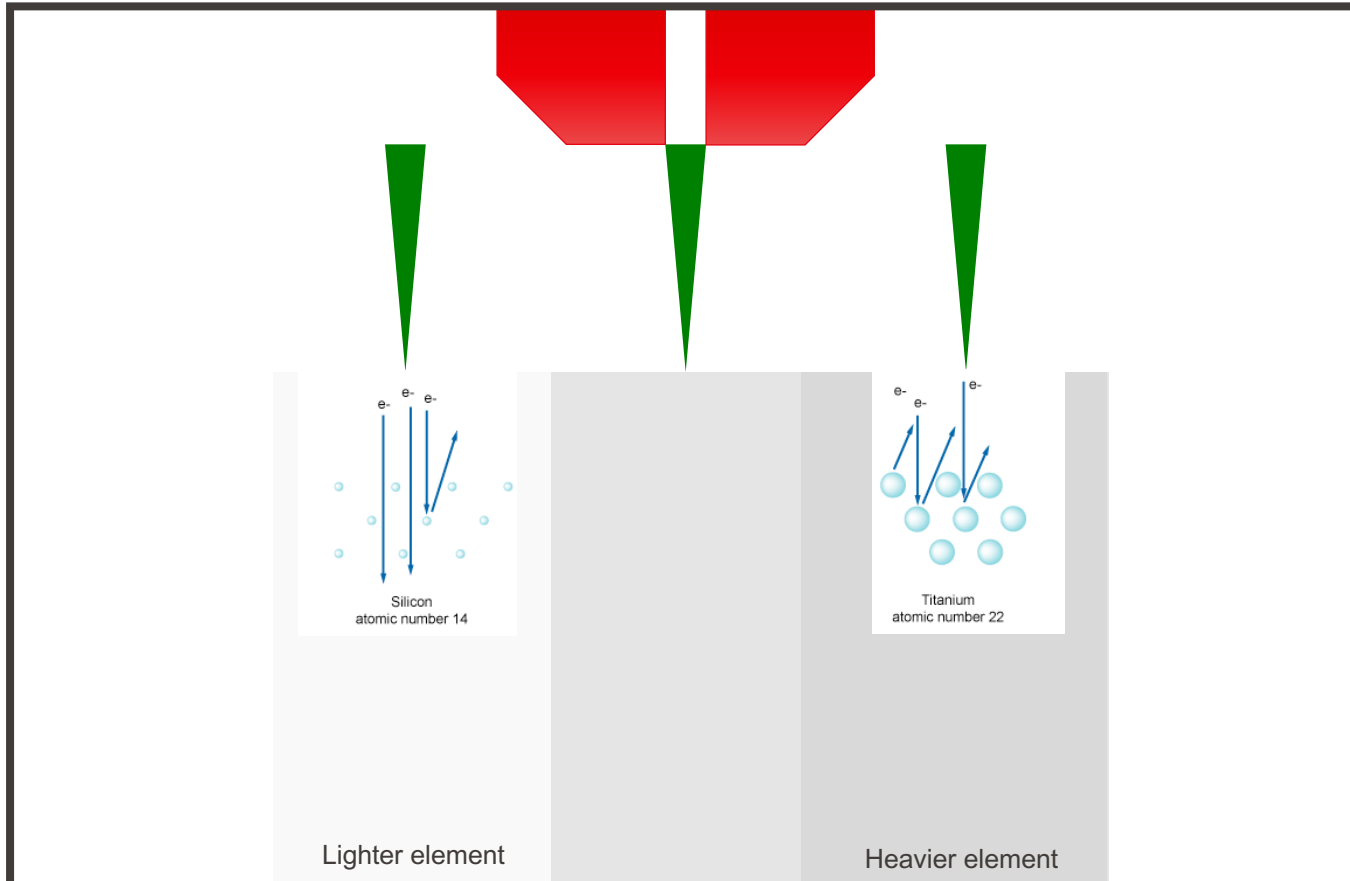

Consequences of using electrons?

Electrons are charged particles

- Sample has to be conductive and grounded to remove the charge on the sample.
- Can we use SEM to image insulating materials? There are ways around this [will see later](#)

Electrons are very light (~2000 times lighter than the smallest atoms) and interact heavily with the matter:

- May cause damage to the sample
- Need for a high vacuum

Vacuum system has to be **VERY** clean:

- Clean samples, not dusty or oily or other solvents
- Use gloves to handle the sample

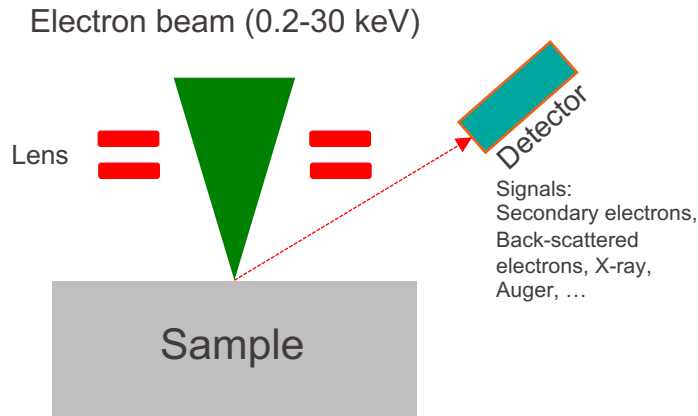

The whole system is kept under high vacuum

Electrons gun generates electron and accelerates them to high speed (energies).

Electron will go through the 1st lens system to form a the smallest possible probe of desired current (i.e. number of electrons / time / surface area)

2nd lens system focuses and scans the probe on sample

Electrons interact with the sample and different signals are generated

Various detectors surrounding sample collect radiated signals for each scan point to form an image

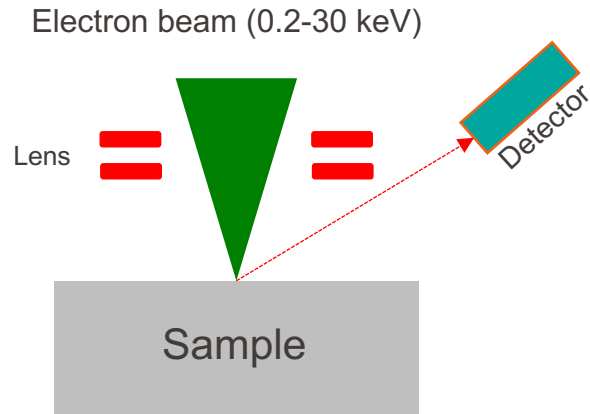

Why we need a vacuum system?

1. Electron propagation is only possible through vacuum (e^- interacts heavily with the matter)
2. A good vacuum system is crucial to reduce contamination and surface modification

Vacuum system

Electron gun
Electron optics
Detectors

Vacuum system has to be **VERY** clean:

- Clean samples, not dusty or oily or other solvents
- Use gloves to handle the sample

Components of the SEM | Vacuum system

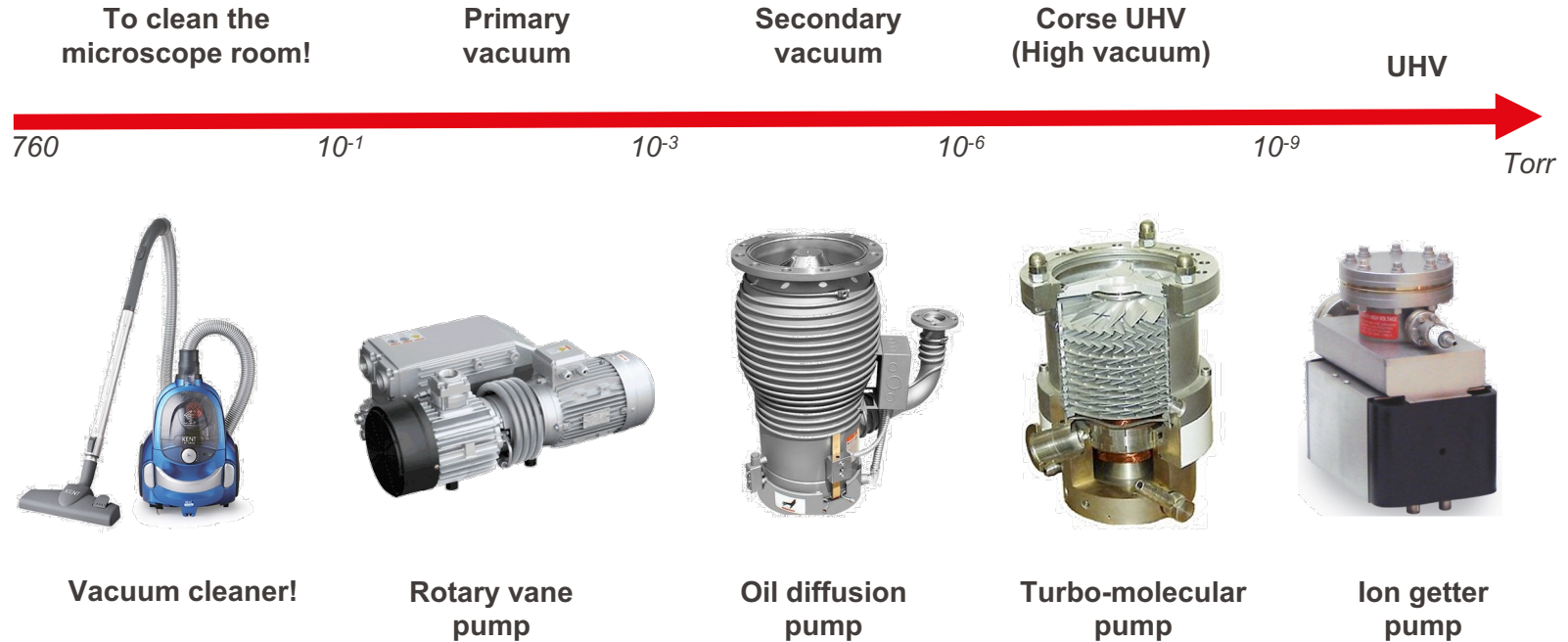

Different kinds of vacuum pumps have different range where they are effective

760 Torr = 1 Atmosphere = 1.013 Bar = 101.325 KPa

Rotary (mechanical) vane pump

Used to back other pumps

- Uses oil
- Noisy

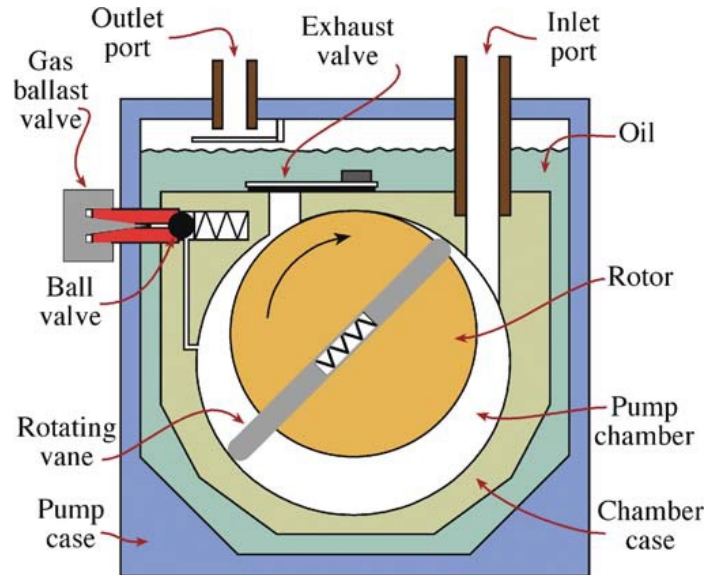

Oil diffusion pump

- Vibration free
- High pumping capacity
- Contamination possible oil vapor

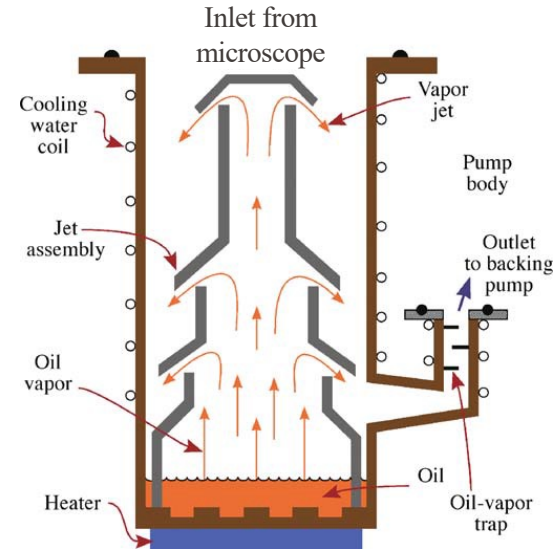

Turbomolecular pump

- Uses a turbine to force gases out from the microscope
- Rotation speed 20'000-50'000 rpm
- Magnetic bearings
- Pumping volumes 50-500 l/s
- Also to pre-pump the specimen chamber in TEM
- Can start (slowly) at ambient pressures, increasing speed as the pressure is lowered
- Ultimately providing UHV conditions at high enough speeds

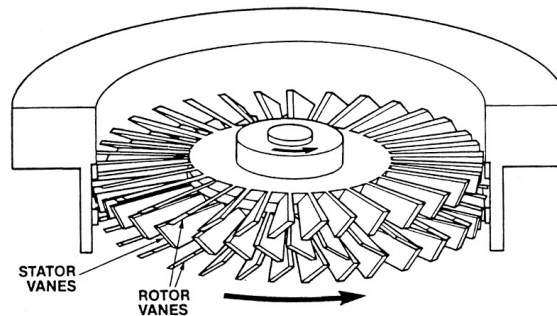

Similar to jet engine

Ion getter pump

- No vibrations
- No exit = trapping: improves vacuum !

The ion pump emits electrons from a cathode. These electrons spiral in a magnetic field (magnetron motion) and ionize incoming gas/air atoms and molecules, which are then attracted to the cathode. The energetic gas ions sputter Ti atoms from the cathode and they condense throughout the pump chamber, mainly on the cylindrical anode, trapping gas atoms.

Thus ion pumps remove gas atoms in two ways;

- by chemisorption on the anode surfaces
- by electrical attraction to the cathodes.

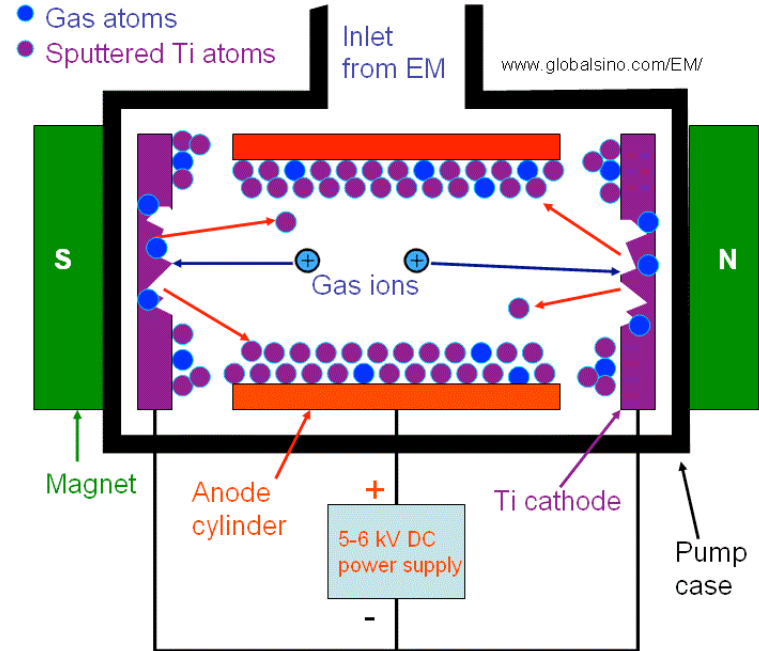

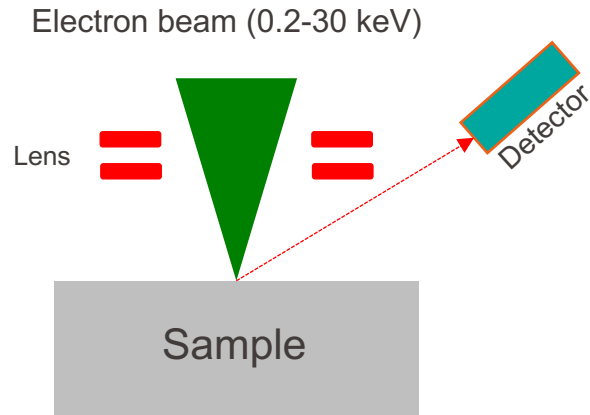

Vacuum system
Electron gun
Electron optics
Detectors

Purpose: To create a narrow intense beam of electrons

Electrons can be released by heat or an electric field

3 types of electron guns:

- Thermionic gun (Thermal)
Heat only
- Cold field emission gun (cold FEG)
Electric field: Potential (voltage) difference
- Heat assisted field emission gun: Schottky emitter
Heat + Electric field

Thermionic gun

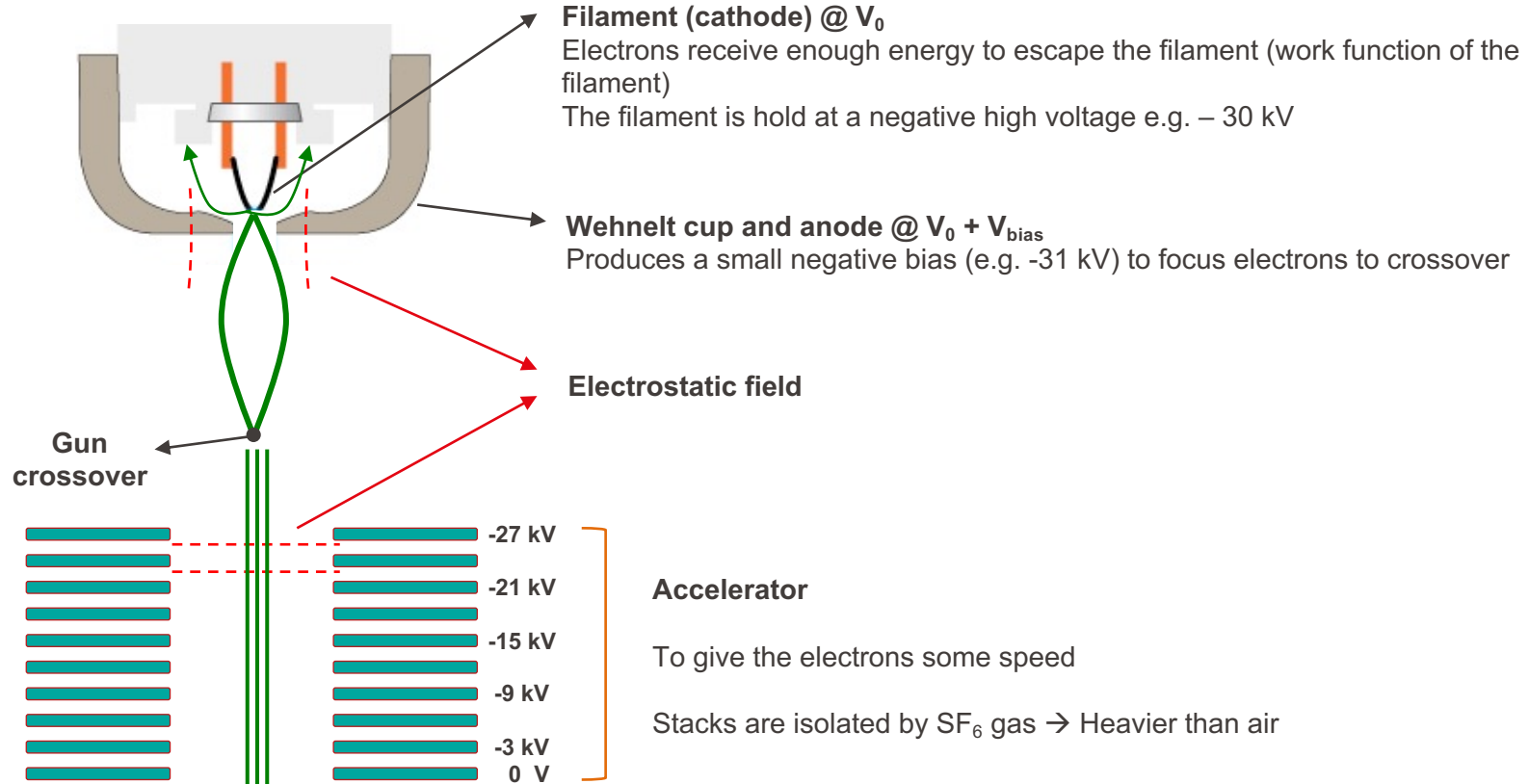

Field Emission Gun (FEG)

By applying an electric field of very high strength at the surface of a metal, electrons are emitted even without heating the metal: *Cold field emission*

- Sharp tip is needed (less than 100 nm)
 - The strength of an electric field E is considerably increased at sharp points. $E = \frac{V}{r} = \frac{1 \text{ kV}}{100 \text{ nm}} = 10^{10} \text{ V/m}$
- Electrons can tunnel straight from the Fermi level out of the filament (usually tungsten).
- Surface has to be pristine (no contamination or oxide)
- 2 types of FEGs:
 - Cold FEG (Ultra-high vacuum condition needed)
 - $E \approx 10^9 \text{ V/m}$
 - W mono-crystal with sharp tip (radius $\sim 100 \text{ nm}$)
 - Heat assisted FEG: Schottky effect* (high vacuum is usually enough)
 - W crystal with ZrO surface treatments to lower the work-function
 - Can work with slightly poorer vacuum

*Schottky effect is the effective decrease of the work function when an external field is applied at the metal surface.

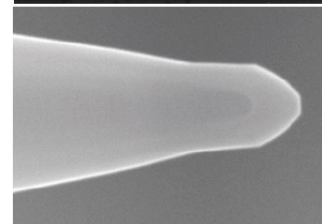
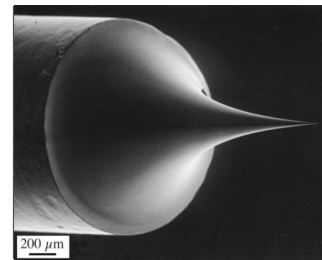

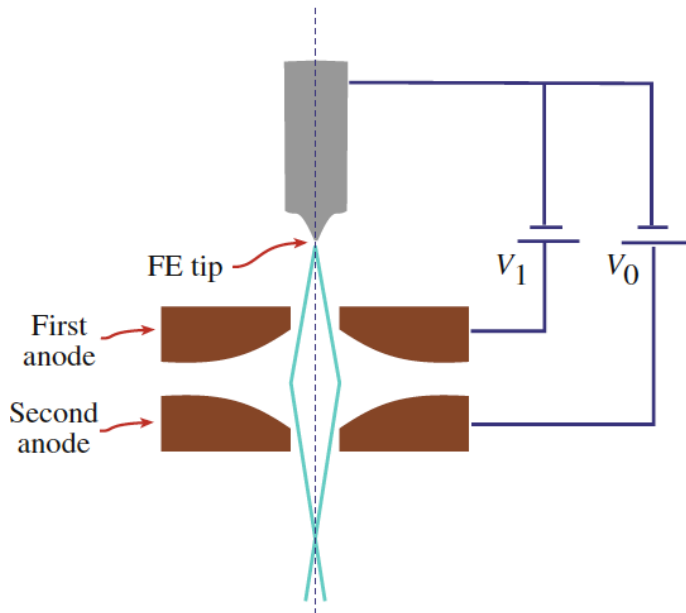

- Anode 1 provides the extraction voltage to pull electrons out of the tip → **Extractor**
- Anode 2 accelerates the electrons to the desired voltage (e.g. 30 kV) → **Accelerator**

The electrons are accelerated through the appropriate voltage by the second anode.

Characteristics

- Tip and anodes form an electrostatic lens
- Cross-over (source) is virtual $\varnothing \sim 5$ nm

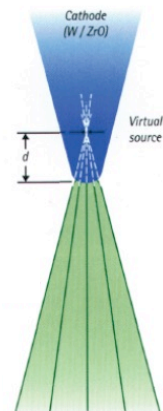



Spatial coherency:

Do all the electrons come from the same direction

An electron beam emanating from a smaller source size has higher **spatial coherency**.

Temporal coherency:

Do all the electrons have exactly the same speed/energy?

A beam with high **temporal coherency** will have electrons of the same wavelength.

Important parameters

- Source and crossover size: determines the probe size (\rightarrow resolution)
- Energy spread: temporal coherency
- Emitted current and current density
- Brightness: current per surface unit and per solid angle
- Current stability
- Vacuum needed

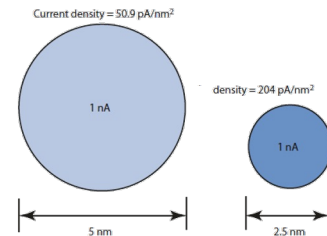

Exercise: For each electron gun indicate which parameter is higher/lower

	Crossover size	Current density	Brightness	Emission current (μA)	Spatial coherency
Thermionic W				100	
Schottky FEG				100	



■ Thermionic gun

- Analogous to volcano
- More electrons form a large tip (10-100 μm)
- Different energies
- Different directions

- Simple to use & maintenance friendly
- Cheap
- Requires only moderate vacuum
- High total beam current
- Low brightness
- High energy spread
- Large source size (10-100 μm)
- Limited lifetime ($\sim 1000\text{h}$ for LaB_6)

■ FEG

- Analogous to child's slide (toboggan)
- Electrons from a very sharp tip radius $\sim 100\text{ nm}$
- Same energy
- Same direction

- High coherence (both spatial and temporal)
- Small energy dispersion ($< 0.4\text{ eV}$)
→ higher resolution at lower energies
- High brightness
- Long lifetime $> 1000\text{h}$
- Expensive
- Ultra-high vacuum necessary
- Cold FEG needs flushing after $\sim 8\text{ hrs}$

Electron gun

	W	LaB6	FEG Schottky (ZrO/W)	FEG cold (W)
Crossover size (nm)	>10⁵	10 ⁴	10-100	3
Emission current (μA)	100	20	100	20~100
Current density (A/m ²)	5	10 ²	10⁵	10 ⁶
Brightness B (A/m ² sr)	5x10⁹	5x10 ¹⁰	5x10¹²	10 ¹³
Energy spread ΔE (eV)	2.3	1.5	0.6~0.8	0.3~0.7
Current stability (%/hr)	<1	<1	<1	5
Vacuum pressure (Pa)*	10 ⁻³	10 ⁻⁵	10 ⁻⁷	10 ⁻⁸
Filament temperature (K)	2800	1800	1800	300

* Might be one order lower

Summary on the electron gun system:

The higher the acceleration voltage, the higher the energy of the electrons.

Electron accelerated by 80–300 kV almost reach the speed of light ($\approx 0.5\text{--}0.8 c$!).

To reach a high-resolution, the accelerating voltage and series of lenses must be immensely stable:

The electron microscope power cabinet contains a number of sources, whose output voltage or current fluctuate not more than one-millionth of the output value. Such stability needs highly efficient and sophisticated electronic circuits, and stable high or ultra-high vacuum.

There exist three types of electron guns: Thermionic, Cold-FEG, and Schottky emitters

Compared to the thermionic sources, FEG provides smaller crossover, is more coherent, and therefore is used in the high-end microscopes for high-resolution imaging.

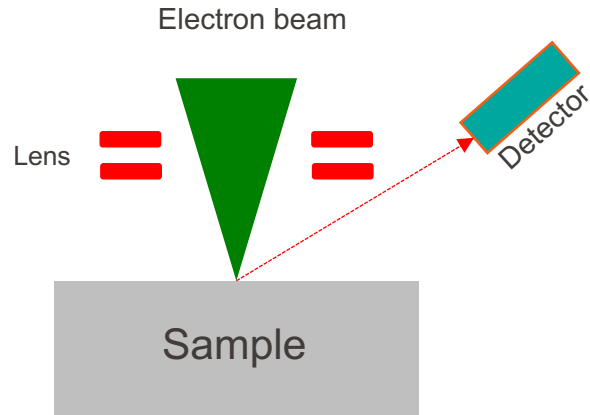

Purpose:

In the SEM we use lenses (**condenser system**) to:

- 1- condense the electron beam into a fine probe (defines probe size and current);
- 2- focus the probe on the sample (**objective lens | e.g. final lens**)

Scan coils raster scan the beam over the sample

Electrons pass through a series of lenses and apertures

The smaller the probe size, the better the potential resolution, but the lower the probe current (number of electrons that hit the sample)

Vacuum system
 Electron gun
 Electron optics
 Detectors

Electro-magnetic lenses focus the electron beam on the sample in an optimal way, similar to the way that the glass lenses focus light.

The electron beam passes through a number of lenses and apertures (\sim micron size).

Lens bends beams to focus it to a point.

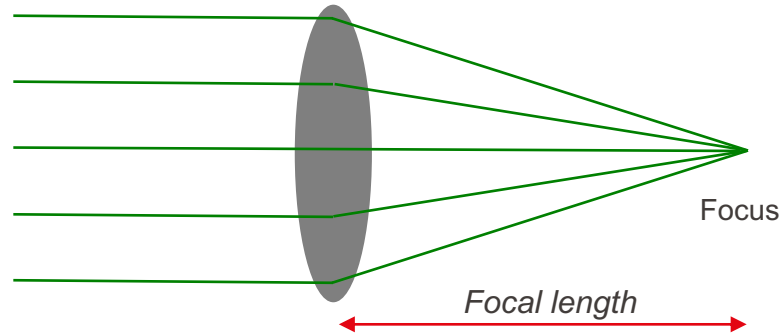

The rays emanating from a point in the object plane come to one common well defined point in image plane.

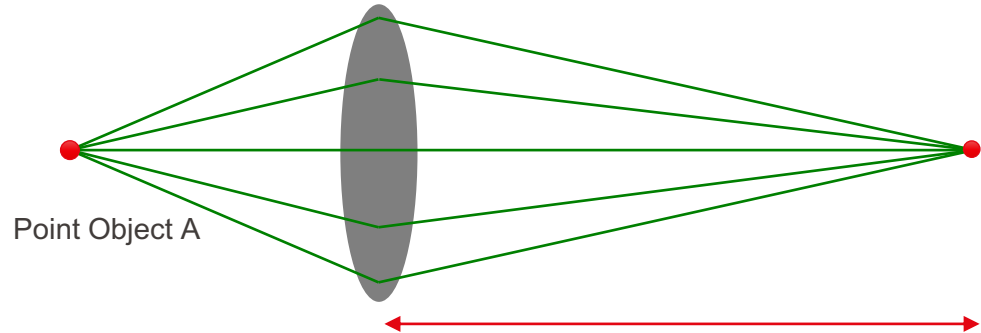

Lens produces a magnified (or de-magnified) image

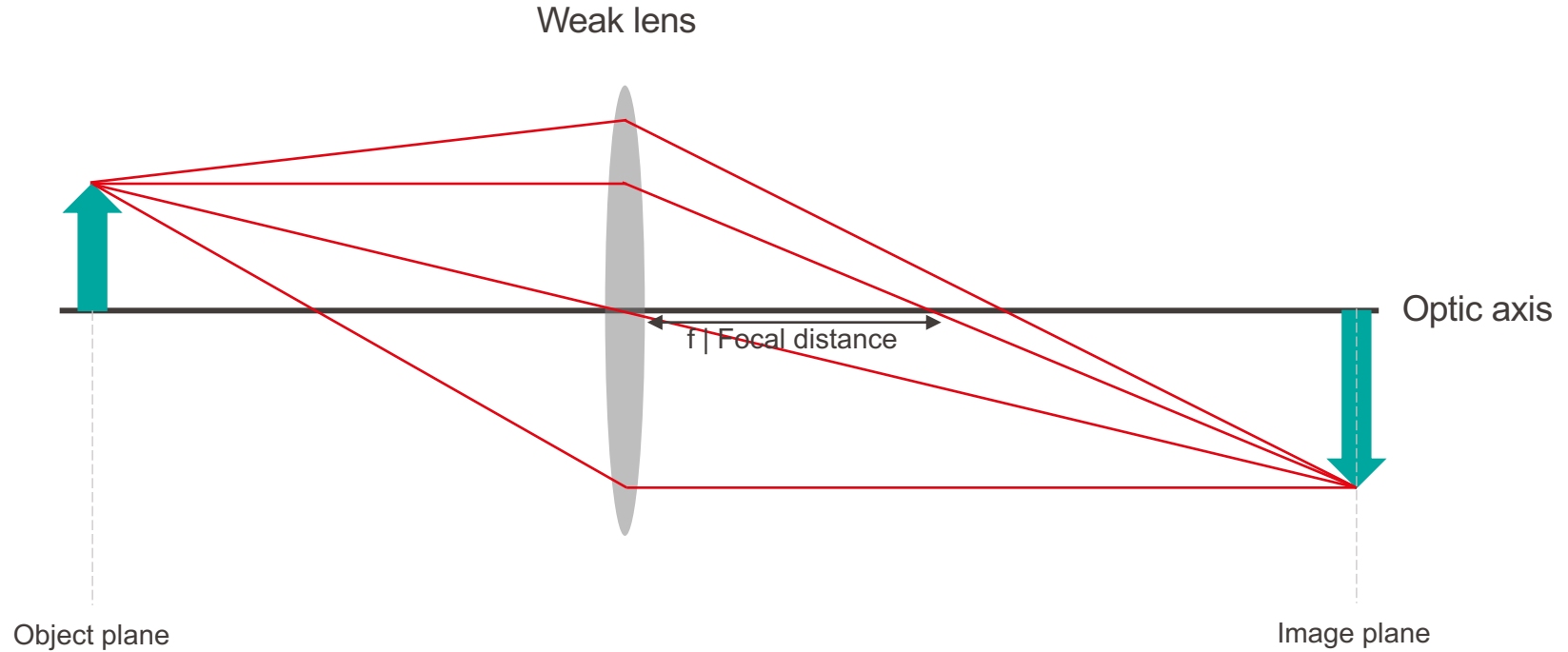

Lens produces a de-magnified (or magnified) image

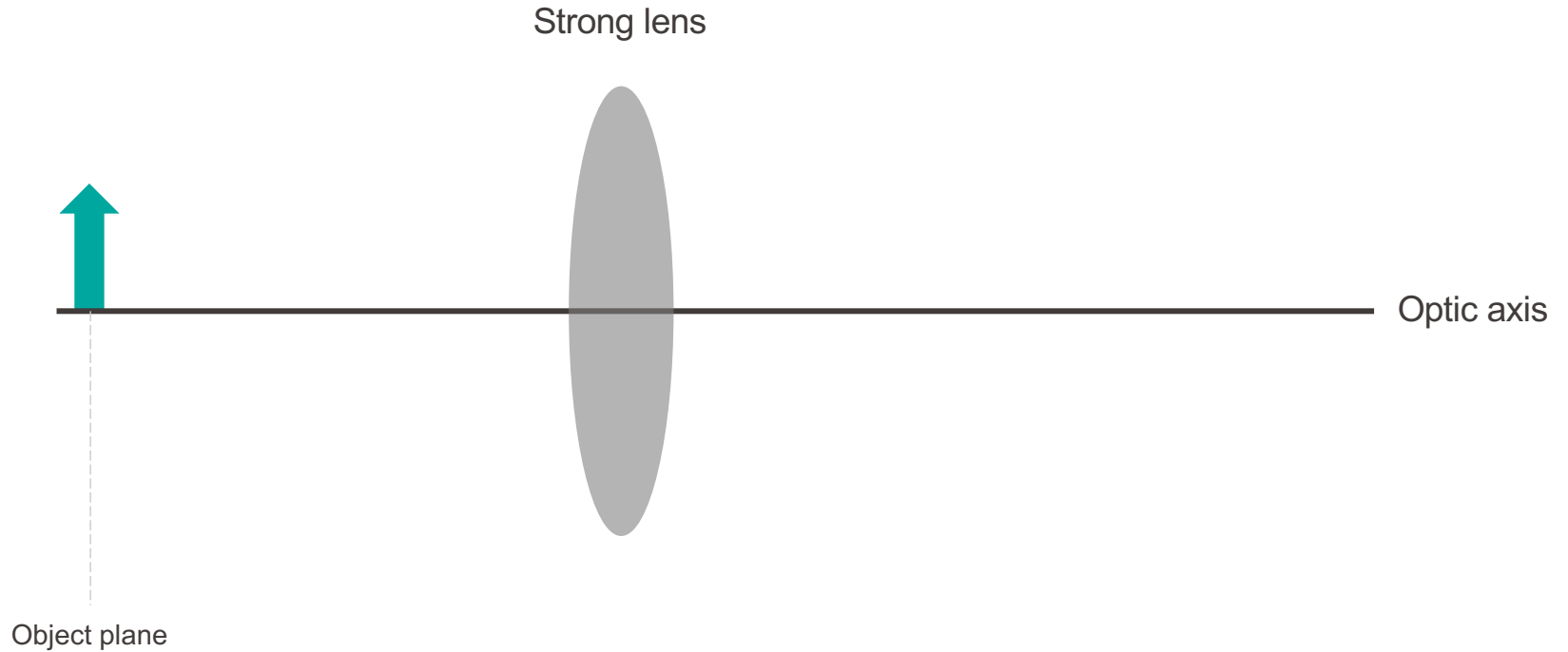

Lens produces a de-magnified (or magnified) image

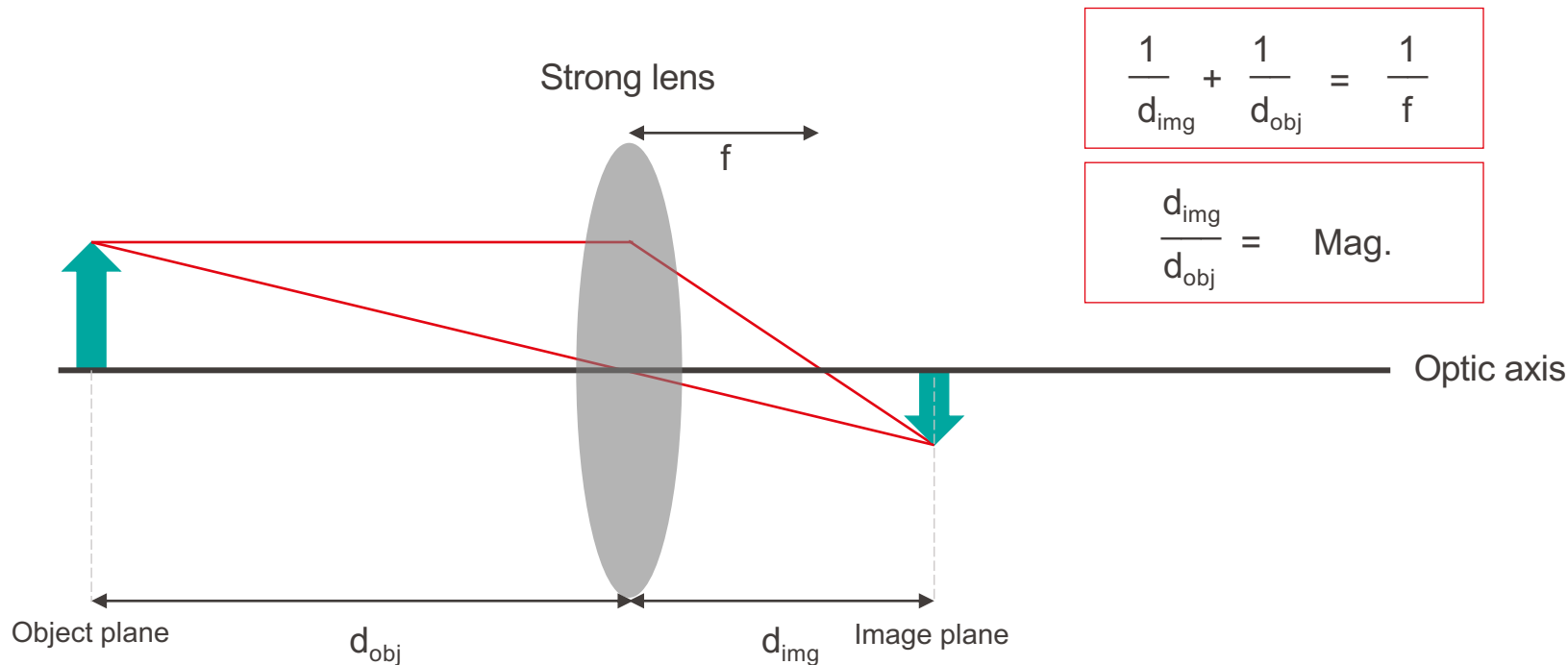

NOTE:

Electron microscopes have more than one lens. Under this circumstance the image plane of the the n_{th} lens becomes the object plane of the $(n+1)_{th}$ lens. The total magnification is the product of the magnification of all the lenses.

- Lenses for light
 - Glass or polymer lenses
 - Deflection of light through changing refraction index



- Lenses for electrons
 - Variable focus
 - Electrostatic
 - Electromagnetic: Lorentz force



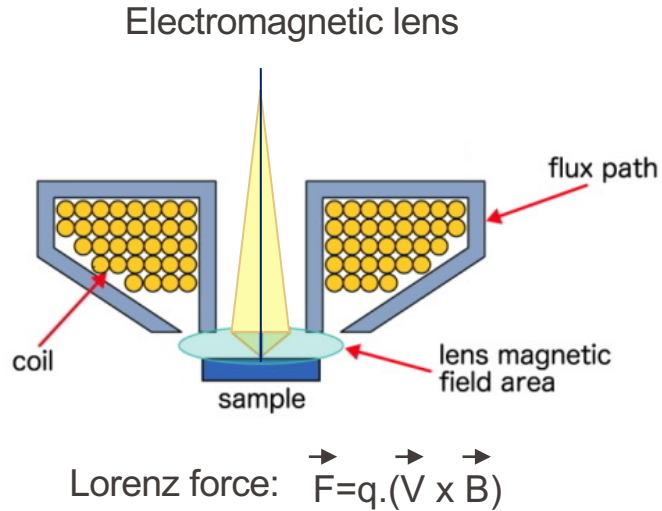

An electromagnetic lens consists of a coil of copper wires inside an iron pole piece.

A current through the coils creates a magnetic field in the bore of the pole pieces which is used to converge the electron beam.

Electrostatic lens

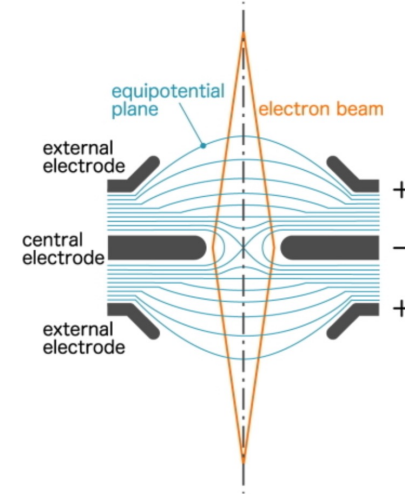

An electrostatic lens, uses an electric field to converge electrons.

The electron beam is converged by arranging the central electrode with a negative charge and the external electrodes with a positive charge above and below the central electrode.

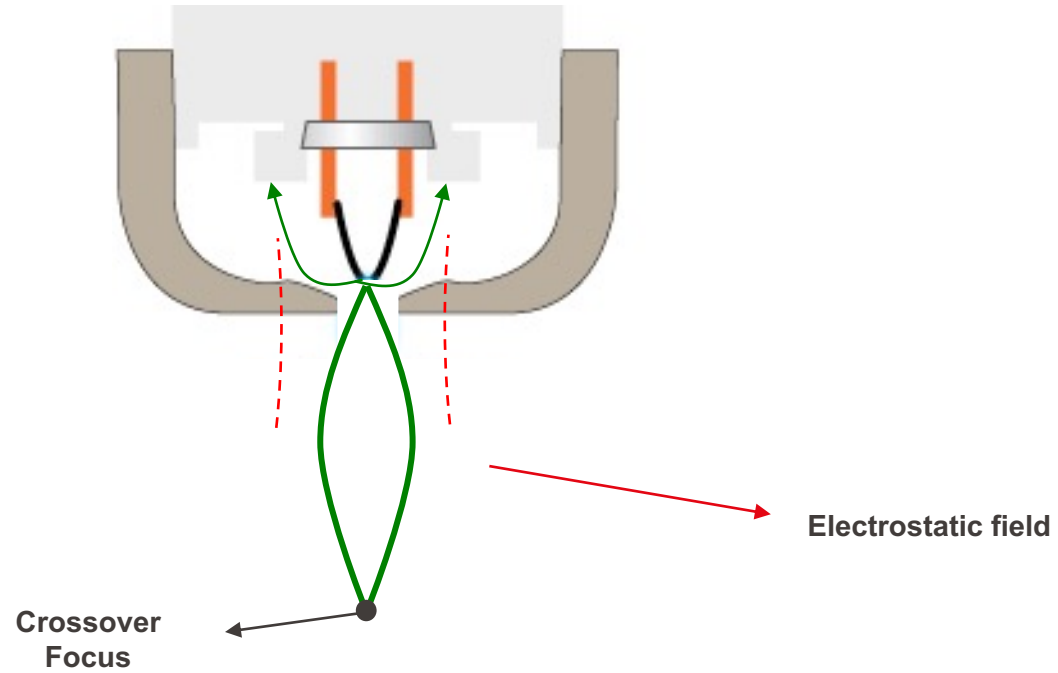

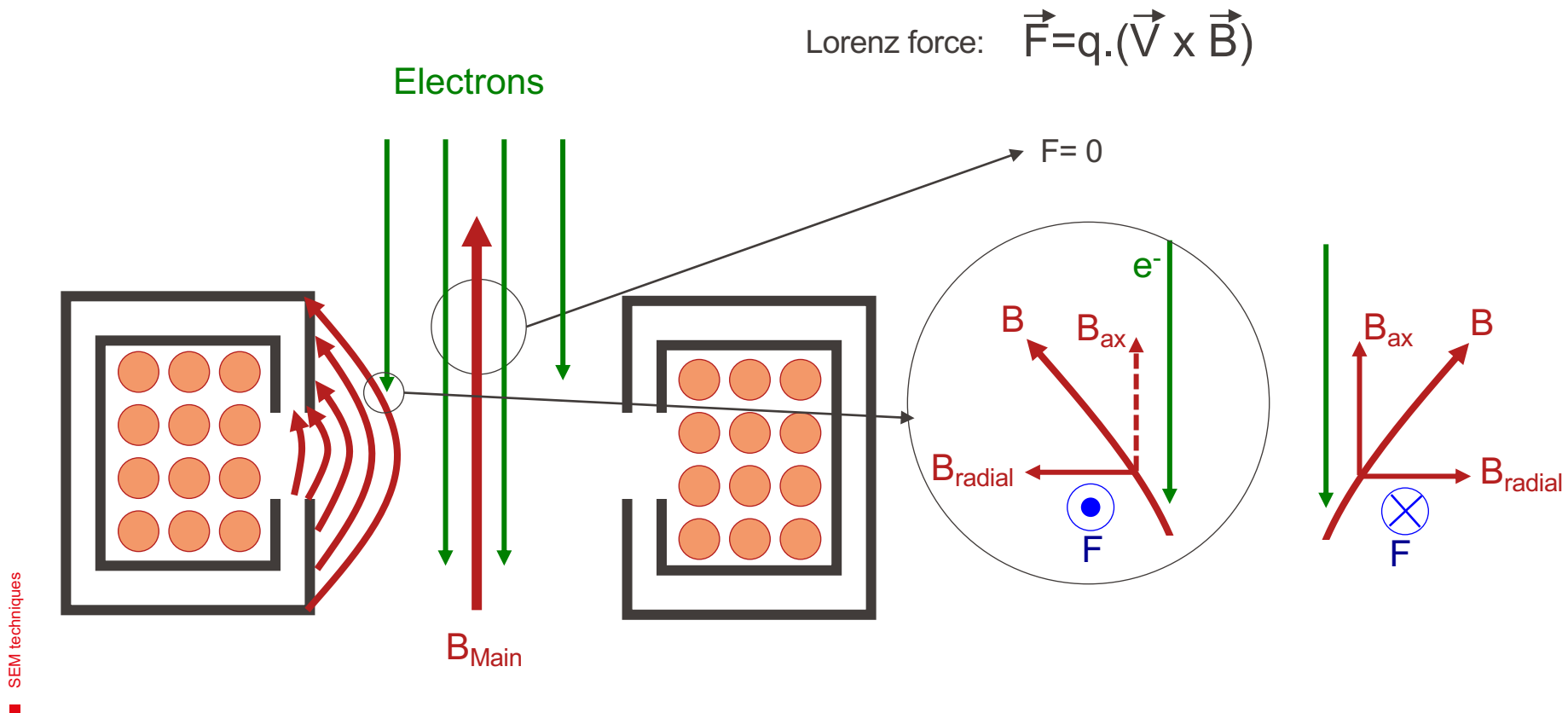

Lorenz force: $\vec{F} = q \cdot (\vec{V} \times \vec{B})$

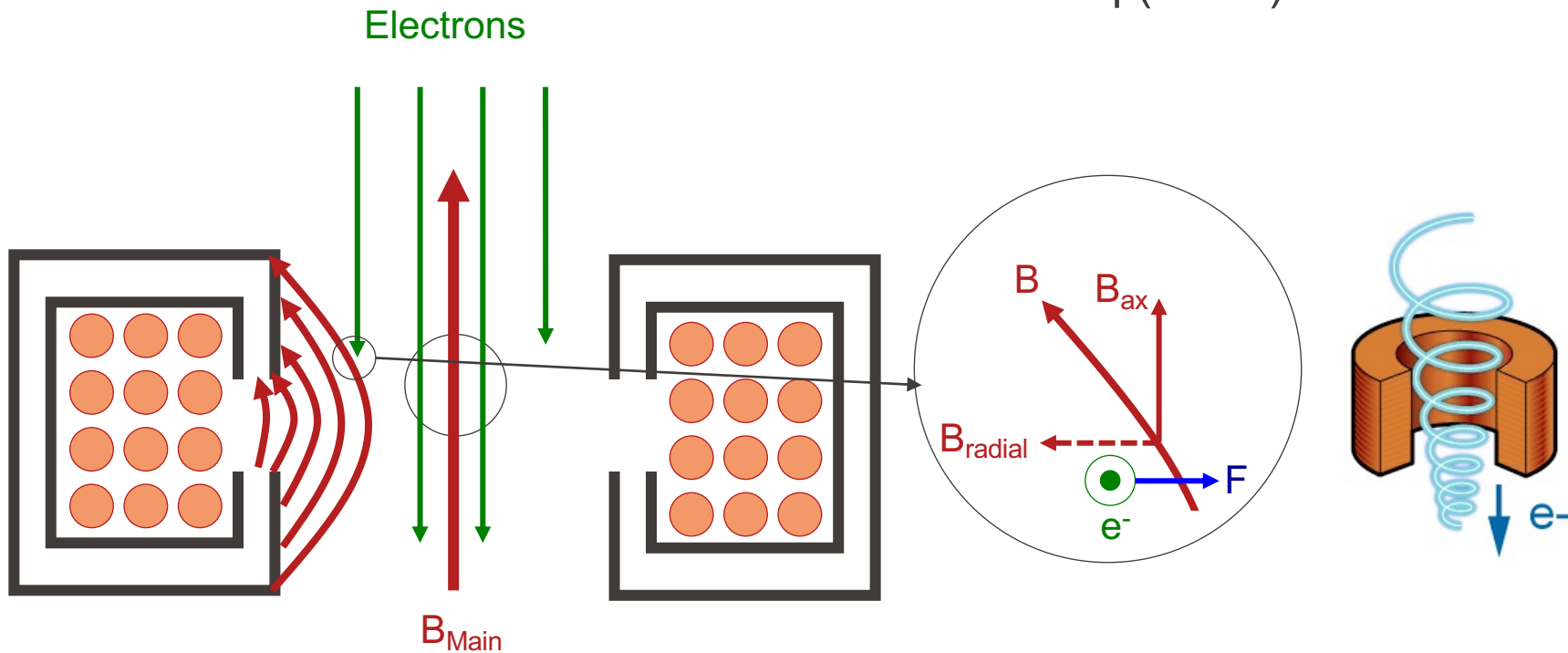

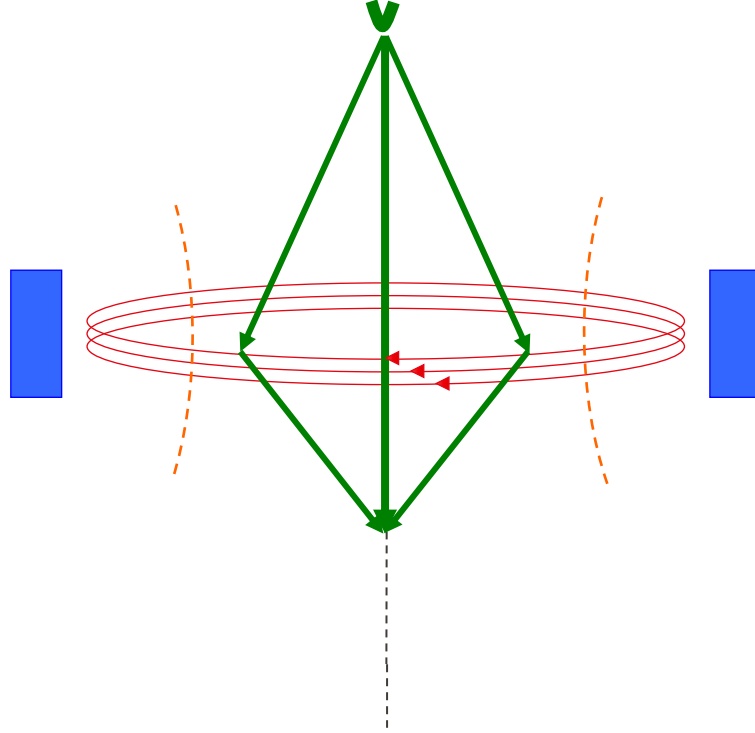

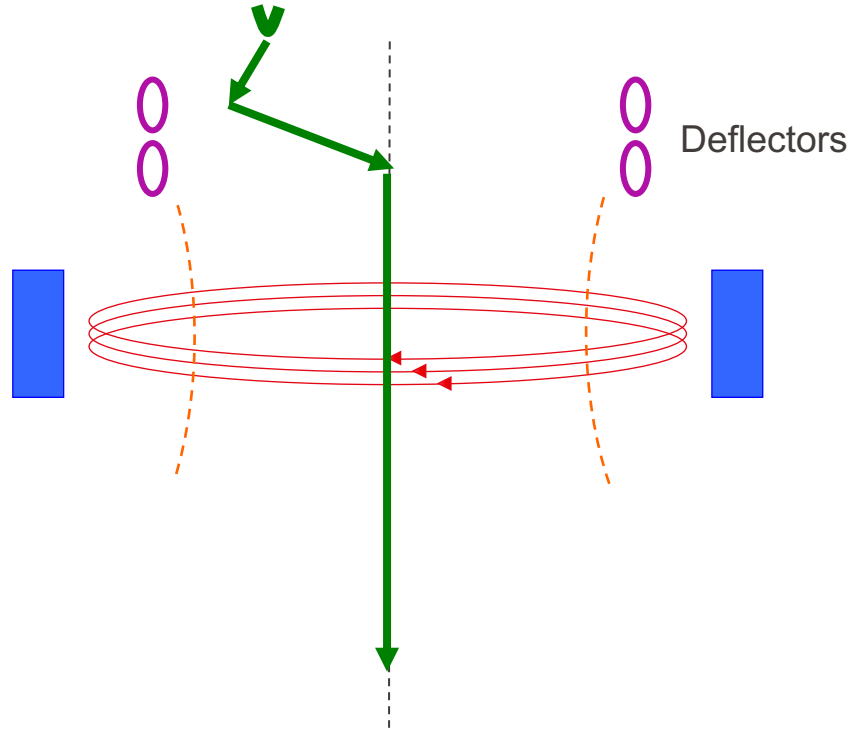

Local temperature changes
Non uniform wiring
Non-uniform current/Magnetic field

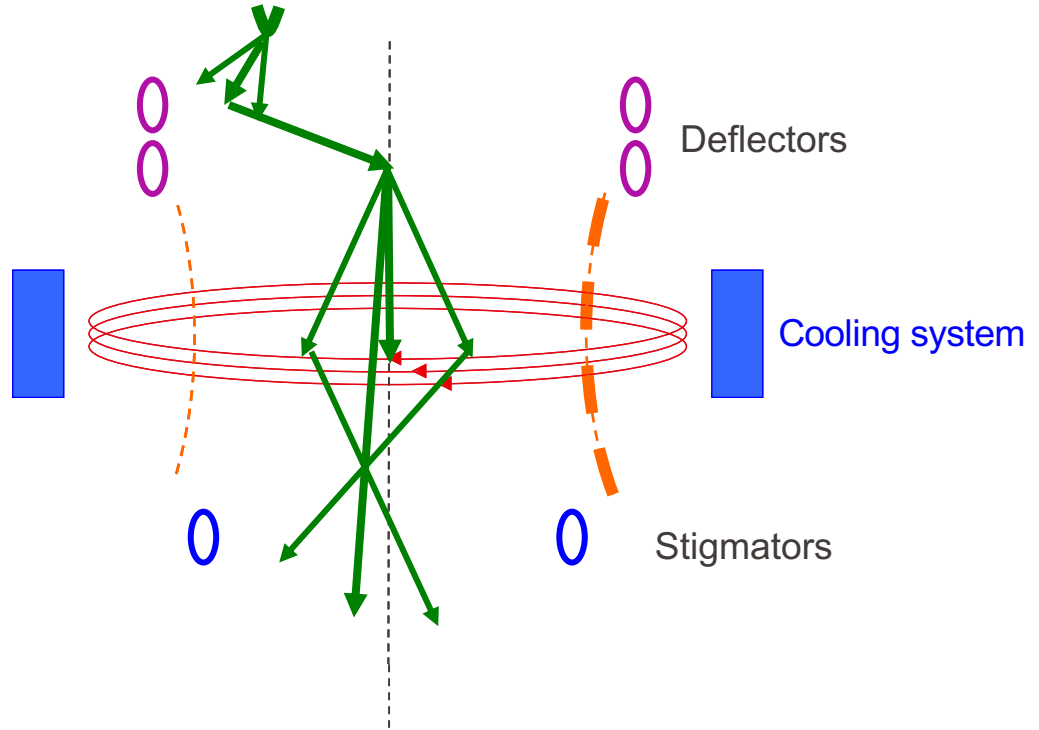

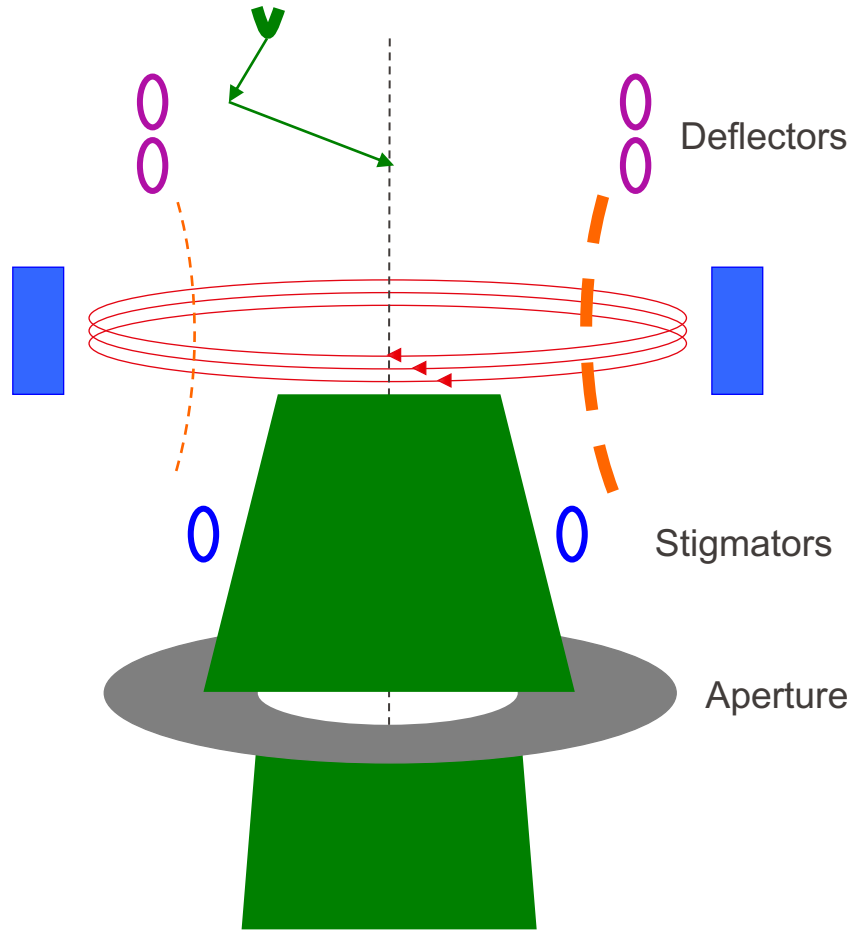

Electron optics in SEM

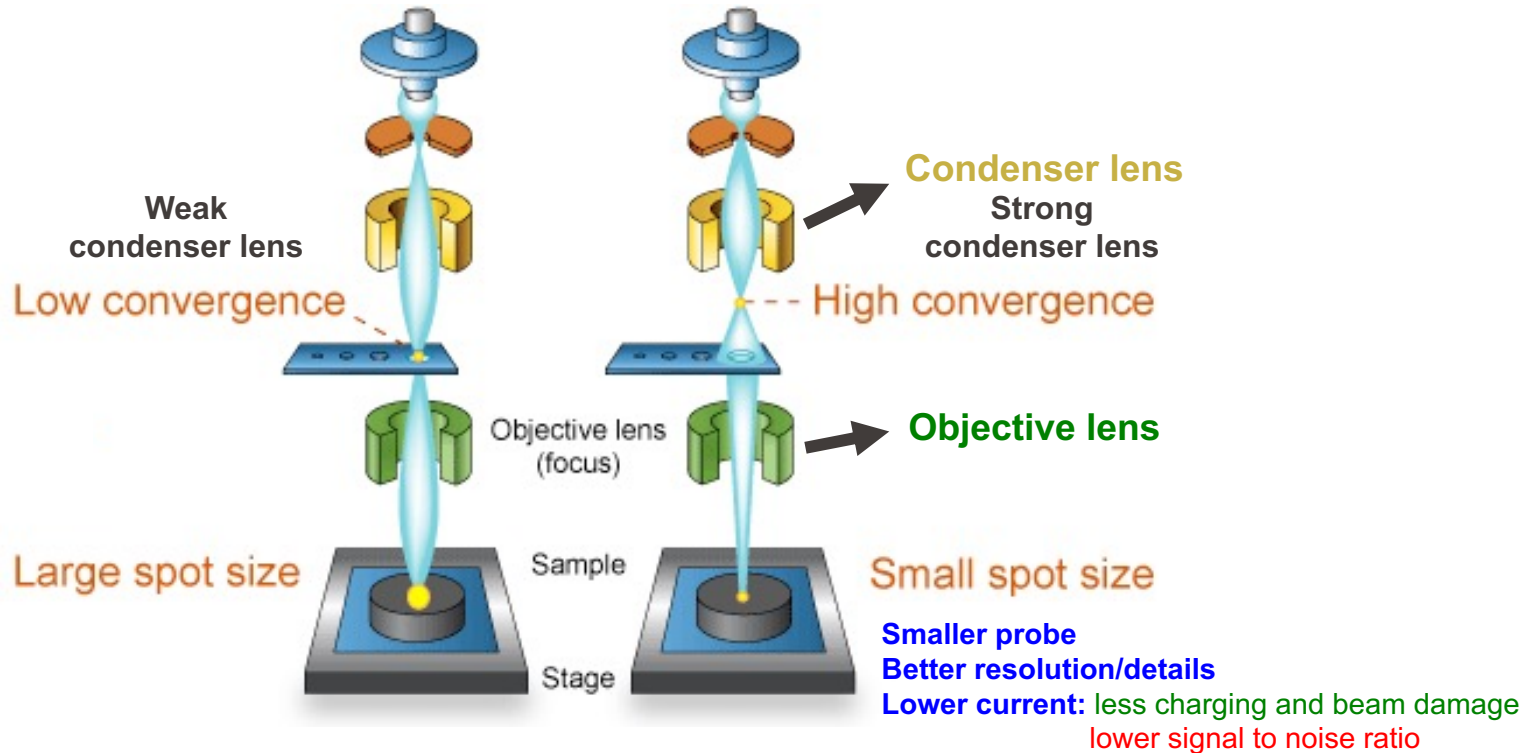

In SEM electromagnetic lenses are used to de-magnify the image of the beam source and to focus the beam on the specimen.

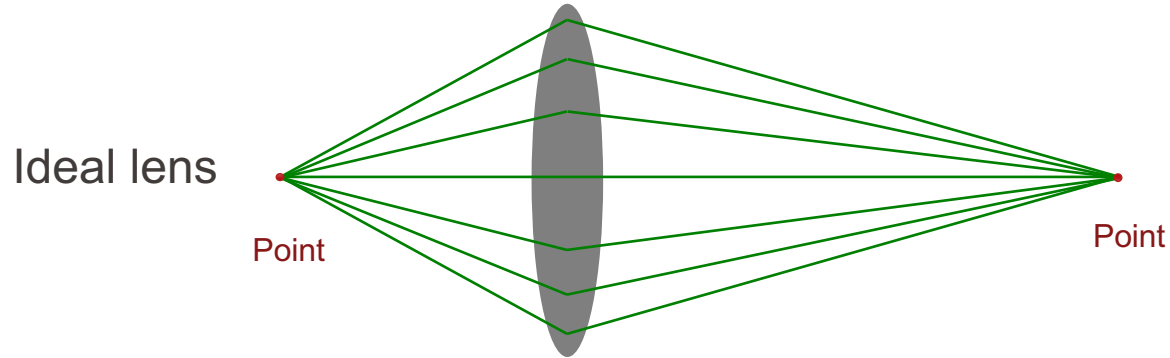

A point source is focused to a point

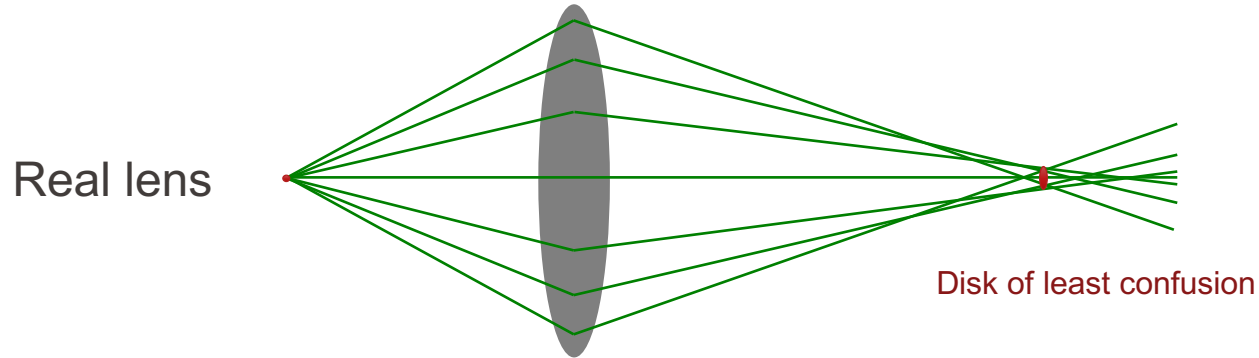

A point source is focused to a disk

Lens aberrations limits resolution!

■ Lens aberrations

- Spherical aberration
- Chromatic aberration
- Astigmatism
- Diffraction effect

Lens aberrations are one of the main limitations to obtaining high spatial resolution.



- Spherical aberration (C_s)

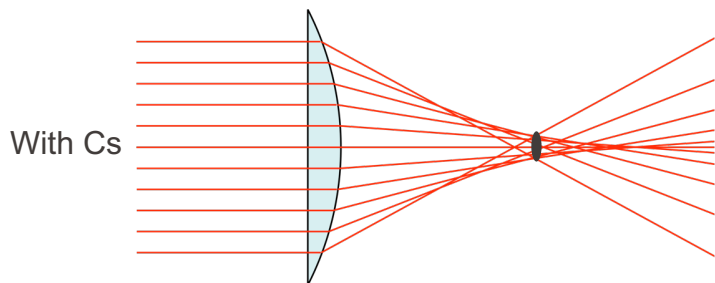
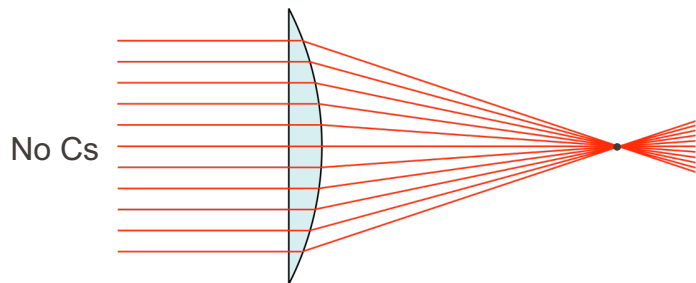

- Parallel rays that pass through the central region of the lens focus farther away than the rays that pass through the edges of the lens.
- Results in multiple focal points and thus a blurred image.
- Larger probe and lower resolution.

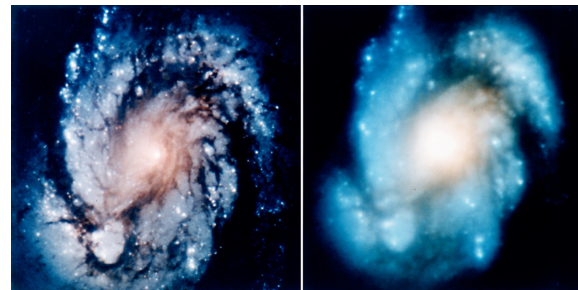

Core of the galaxy M100 ©NASA

- Spherical aberration (C_s)

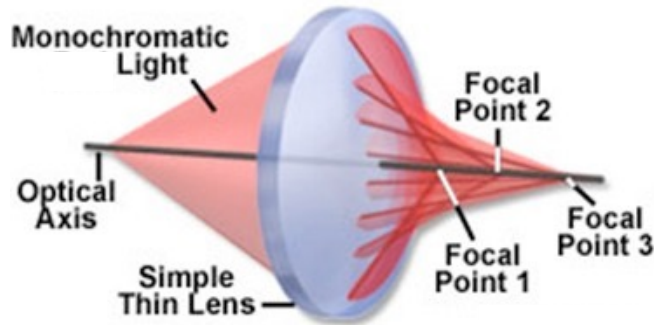

- Focal length depends on the distance from optical axis
- Image of the object is dispersed along the optical axis
- Circle of least confusion

$$d_s = \frac{1}{2} C_s \lambda^3$$

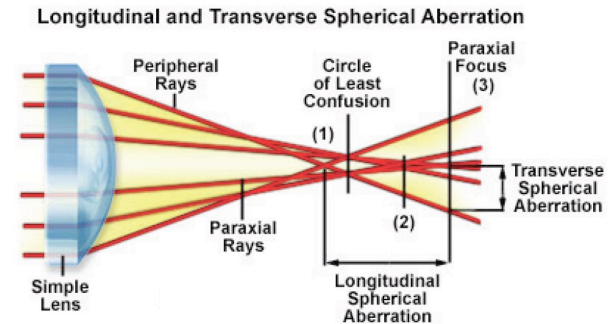

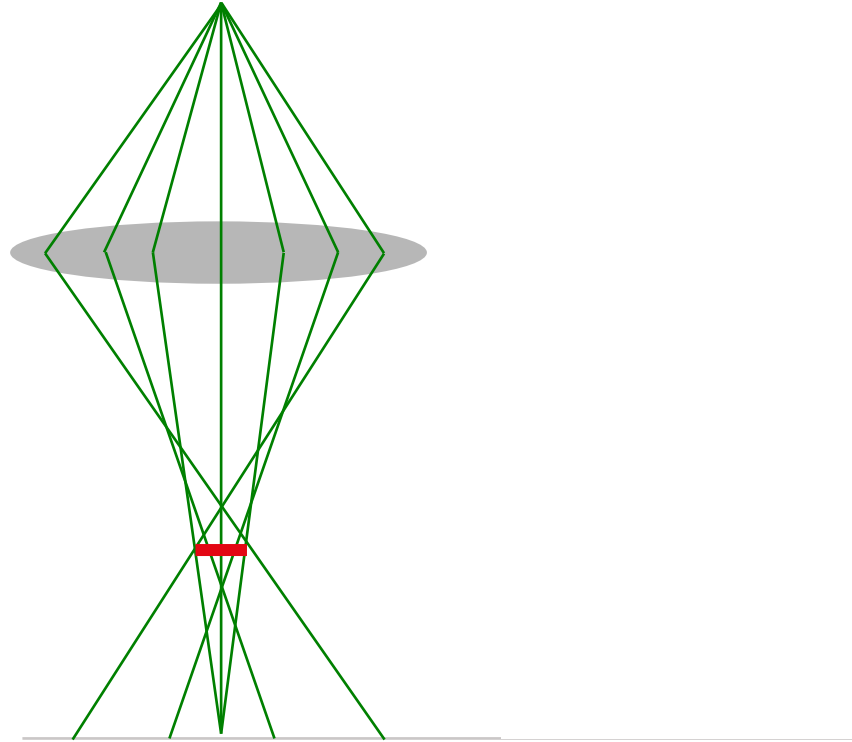

How to lessen the effect of spherical aberration?

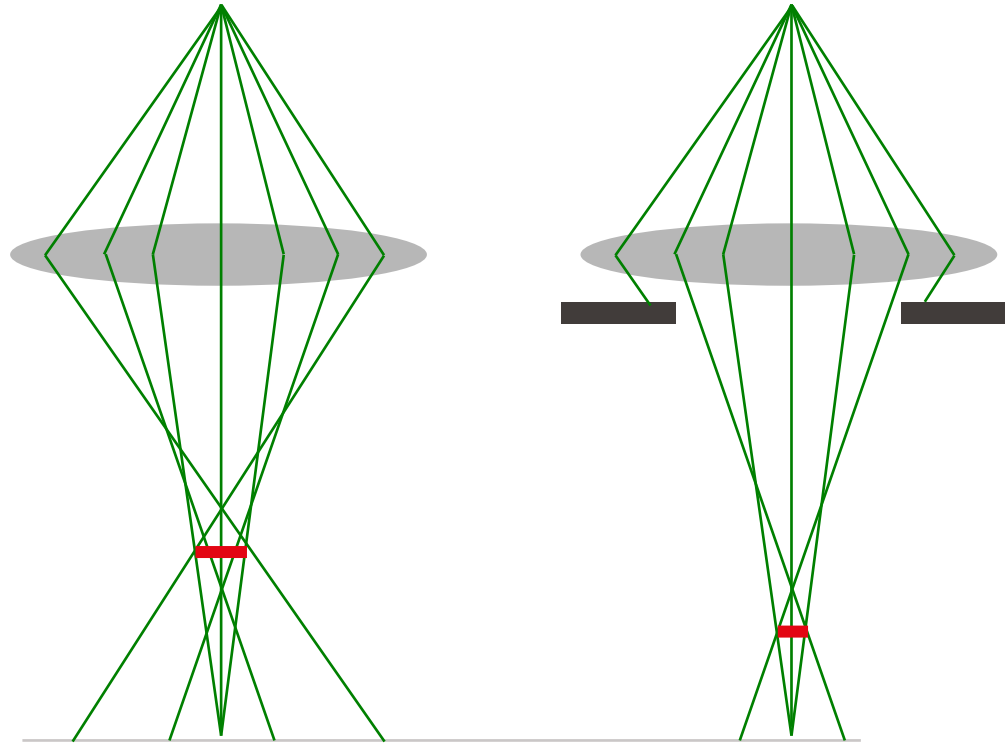

Inserting an aperture can lessen the effect of spherical aberration
But it comes with a cost = lower current and more diffraction effect

- Chromatic aberration (C_c)

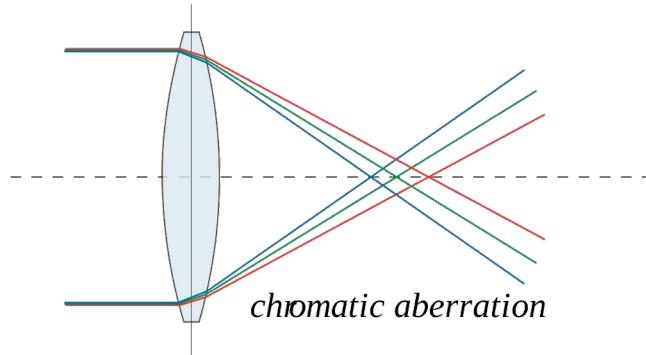

- Lens cannot focus all energies (wavelengths) to the same convergence point.
- Electrons of lower energy will be bent more strongly.
- Correcting the aberration is necessary, otherwise the resulting image would be blurry and delocalized, a form of aberration where periodic structures appear to extend beyond their physical boundaries.
- C_c increases with source energy spread.

- Astigmatism

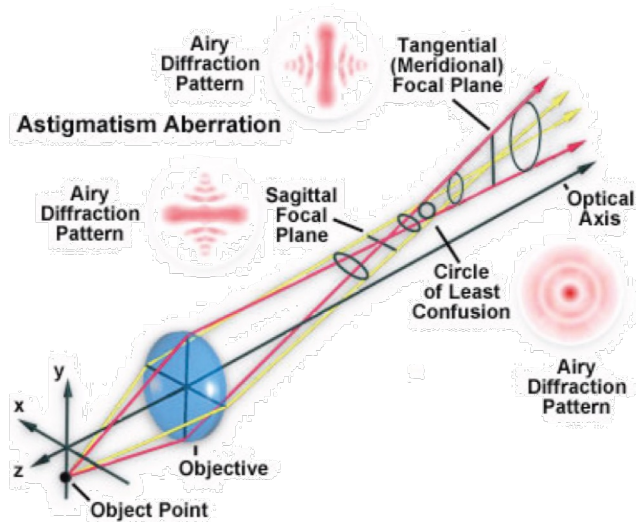

- Focal length varies for different axes of the lens.
- Image will appear “stretched” with changing the focus
- Caused by:
 - imperfections in the manufacturing of the pole-piece and the copper windings
 - Stray magnetic field

■ Astigmatism

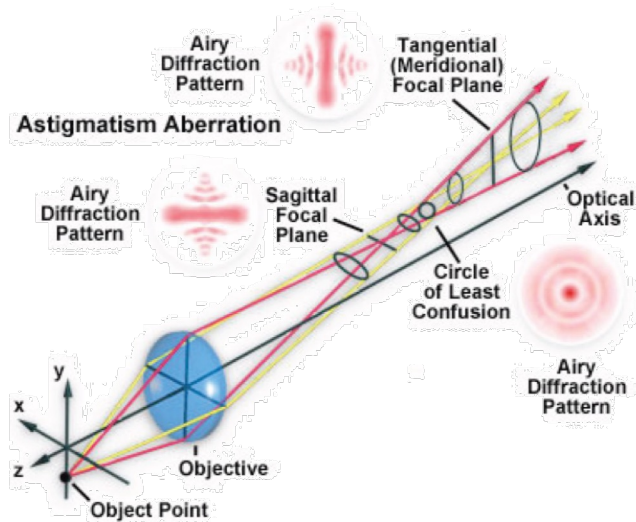

Under focus image

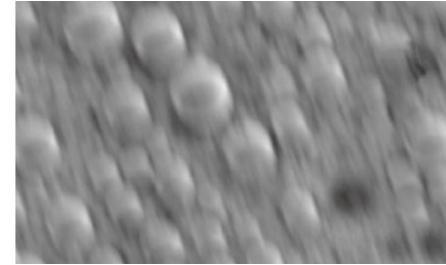
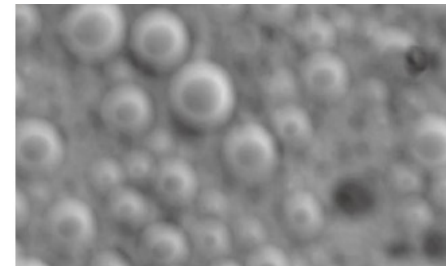
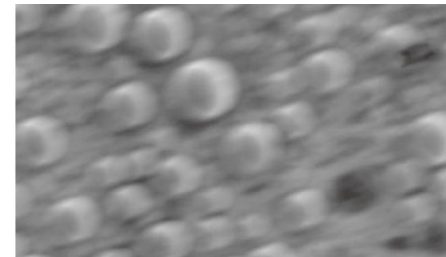

Image in focus with astigmatism



Over focus image



Astigmatism correction

- In light optics

- Correction with cylindrical lenses

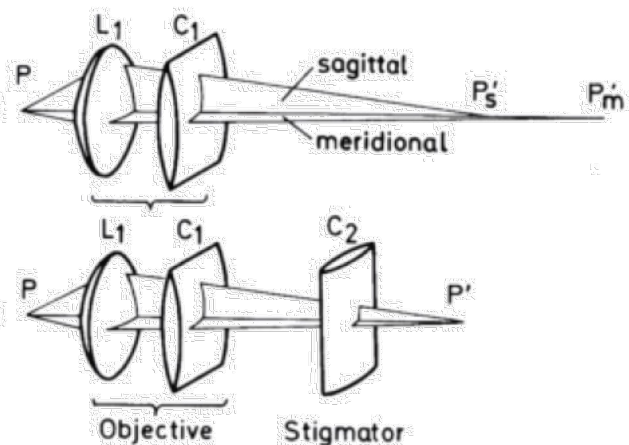

- In electron optics

- Correction with quadrupole lenses
- 2 quadrupole lenses under 45 degree allow to control strength and direction of correction

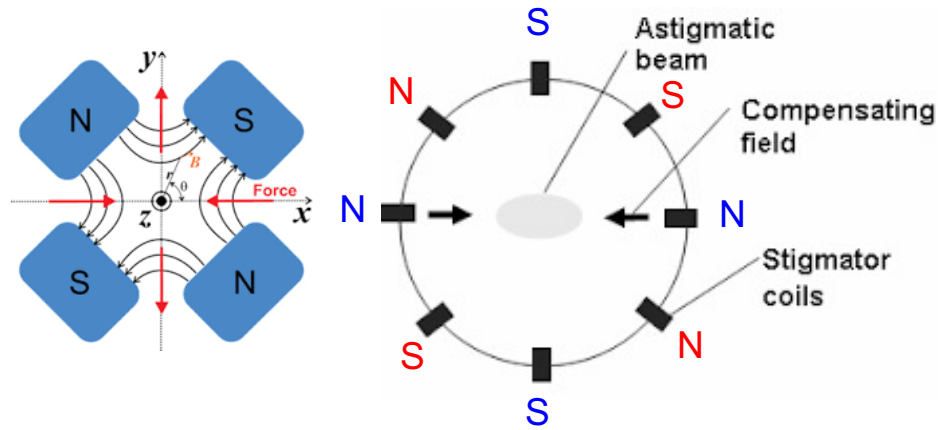

With astigmatism

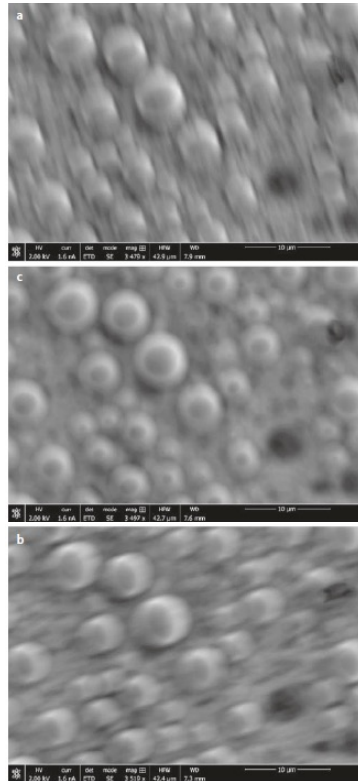
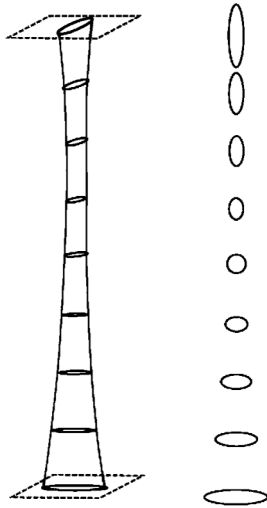

Astigmatism corrected

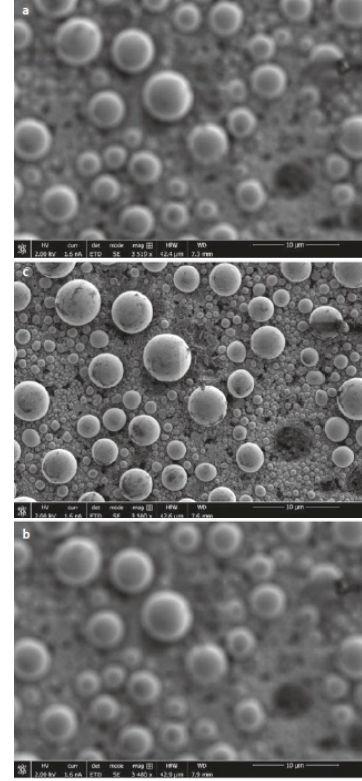
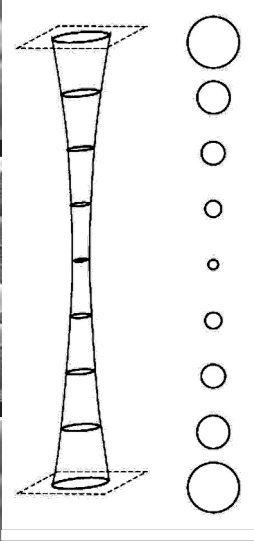

■ Diffraction effect

- Light/electron rays passing through a small aperture will begin to diverge and interfere with one another
- → Diffraction | Airy disks

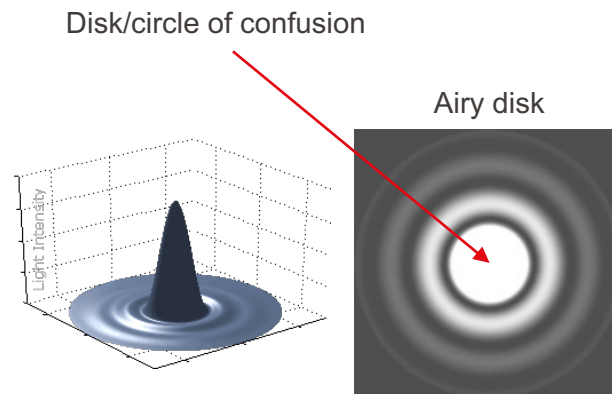
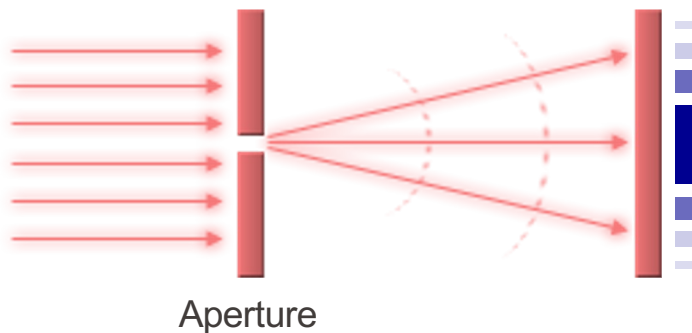

■ Diffraction effect

- Airy disks when light/electrons passing through a small opening (such as your camera's aperture)

Disk/circle of confusion

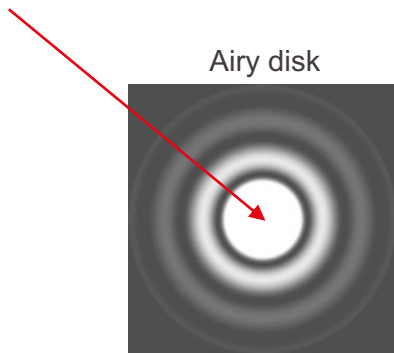

Airy disk

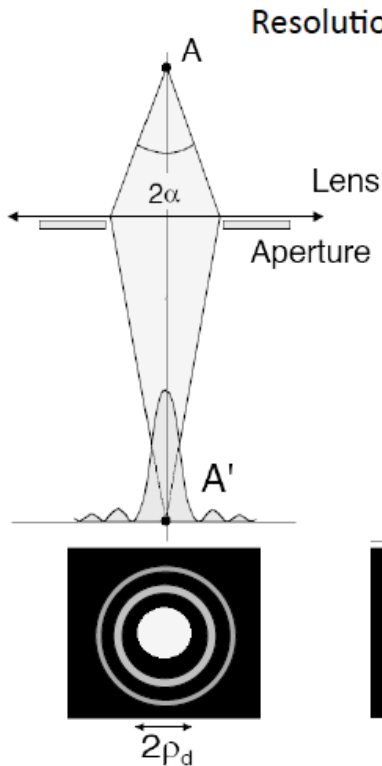

Resolution: diffraction effect

Means using large a aperture!
What about Cs?

Rayleigh criterion
 $\rho_d = 0.61 \lambda / \alpha$

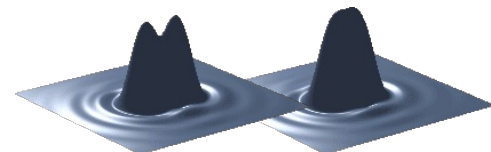
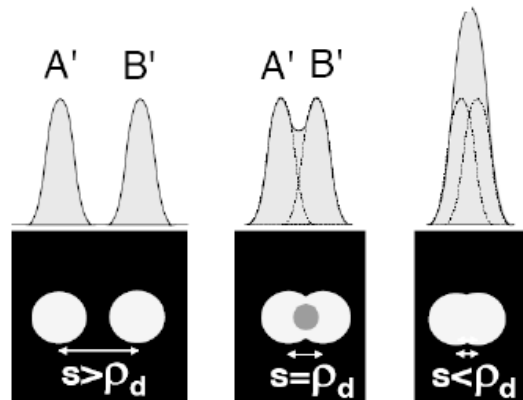

Resolution limit No longer resolved

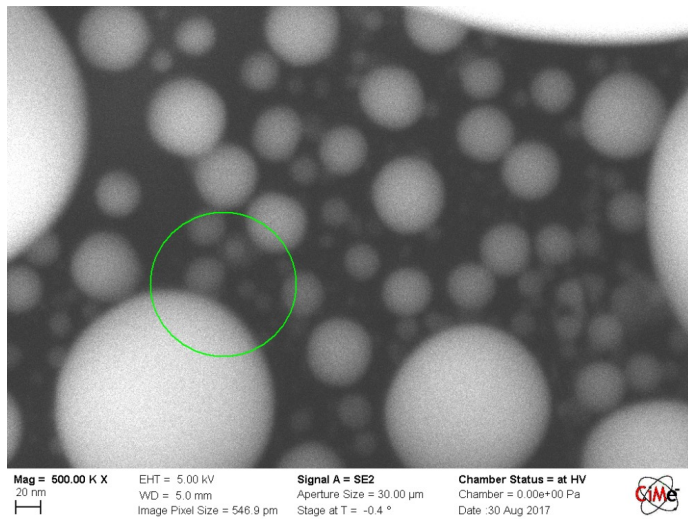
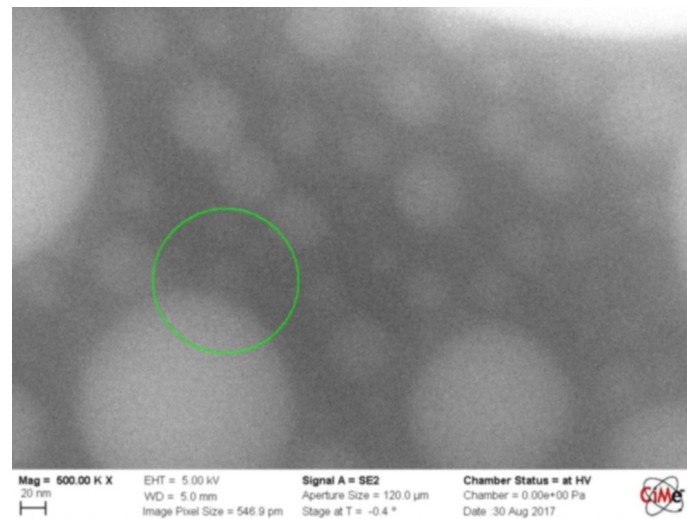
Optimal Aperture size (30 μm)Large Aperture size (120 μm)

Though large apertures produce larger convergence angles (less diffraction effect),
BUT spherical aberration increases probe size and reduces resolution.

Summary on electron optics:

Electromagnetic lenses are used to project the beam cross-over on the sample surface to generate the smallest possible probe, and to focus the beam on the specimen.

Condenser lenses are used to demagnify of the image of the beam source.

The objective lens is the final focusing lens before the sample used to adjust the beam focus on the specimen.

There are a number of points to emphasize about lenses when thinking about SEM:

- **A small probe always comes with a decrease in probe current.**
- **Smaller aperture: results in a smaller probe with less current, lowers C_s , but increases the size of the Airy-disk (diffraction effect) below a certain size.**

→ Doing SEM involves understanding the trade-offs

Components of the SEM

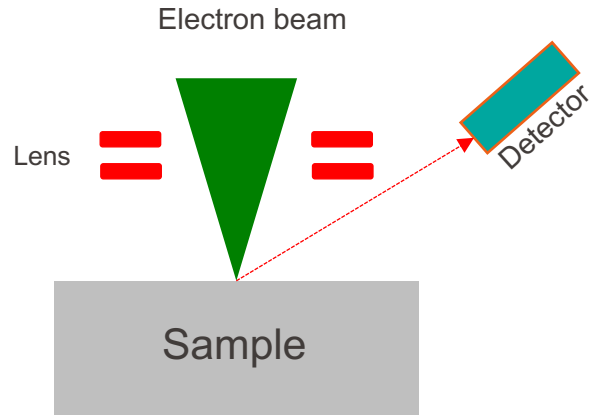

Purpose:

To see the sample we detect the electrons emitted from the sample.

The signal that is proportional to the number of electrons emanating from the sample at each scan position

Scan coils, detector and display (monitor) are synchronized

There exist detectors for electrons, x-ray, etc.

Vacuum system
Electron gun
Electron optics
Detectors

Two typical electron detectors for the SEM:

- Scintillator/Photomultiplier
Everhart-Thornley detector
- Semiconductor detector
Silicon diode with a $p-n$ junction

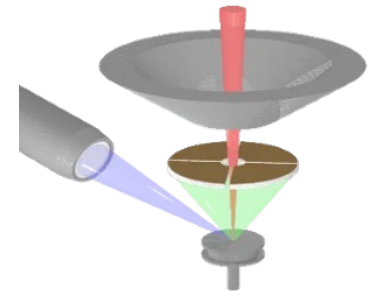

Electron detectors

Semiconductor detectors

- When struck by the high-energy electrons, most of the beam energy is transferred to valence-band electrons in the Si which are excited across the band gap into the conduction band thus creating electron-hole pairs (3.6 eV / electronhole pair).
- e.g. 10 keV \rightarrow \sim 2800 electrons
- Thus, the incoming electron signal is converted to a current in the external circuit between the surface contacts.

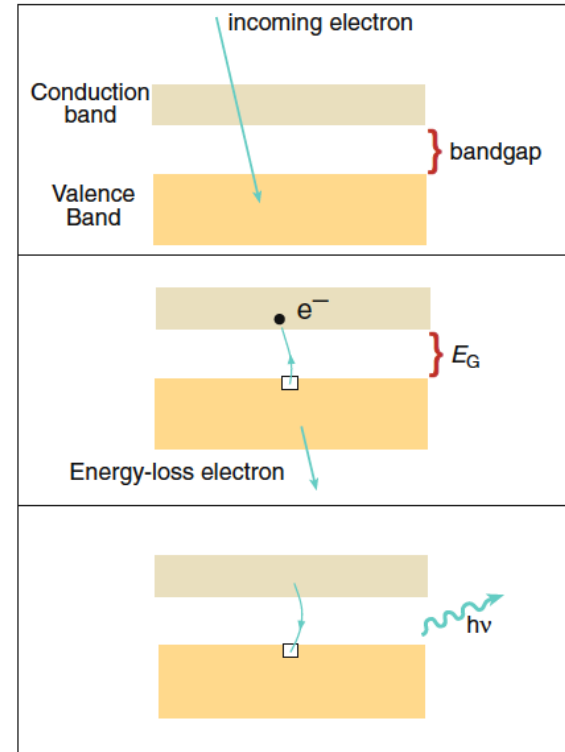

Electron detectors

Semiconductor detectors

- Si diode with a p-n junction close to its surface collects
 - By doping the Si (e.g., by ion implantation of n-type impurity atoms into p-type Si or vice versa).
n-type | Gives free electrons to semiconductor
 - By evaporating a thin layer of Au on the surface of high-resistivity n-type Si, or evaporating Al onto p-type Si (i.e. surface-barrier detector or a Schottky diode).

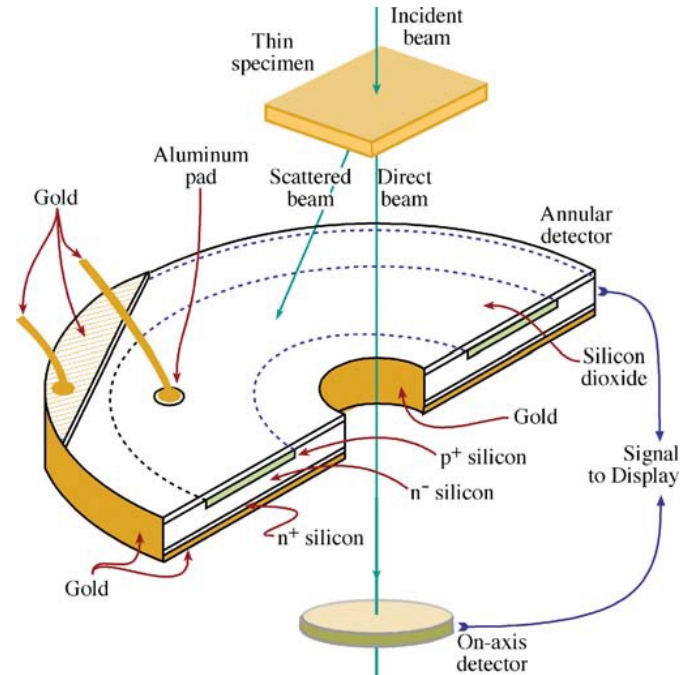

Electron detectors

Semiconductor detectors

- Very efficient at picking up and amplifying electron signals
- Large collection angle
- Cheap and easily fabricated
- Some diodes are split in 2 or 4 quadrants to bring spatial electron distribution information

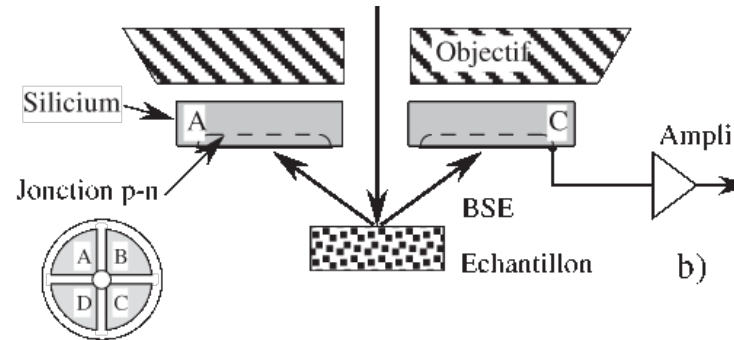

- Slow | Not responsive to rapid changes in signal intensity (poor signal at TV frequency)

Electron detectors

Scintillator-Photomultiplier

Everhart-Thornley detector (ETD)

Composed of a scintillator inside a collector (Faraday cage) inside the specimen chamber, and a photomultiplier (PM) system, attached to the scintillator via a light pipe.

- The Faraday cage with a positive potential attracts low-energy electrons
- The scintillator with a high positive voltage (~ 10 kV) accelerates the incoming electrons and emits visible light when struck by fast electrons
- Light (photon) from the scintillator travels via fiber optics to a photocathode, where the light is re-converted to electrons
- The electron signal is then multiplied (amplified) by several electrodes (dynodes) in the PM tube before being used to modulate the display screen.

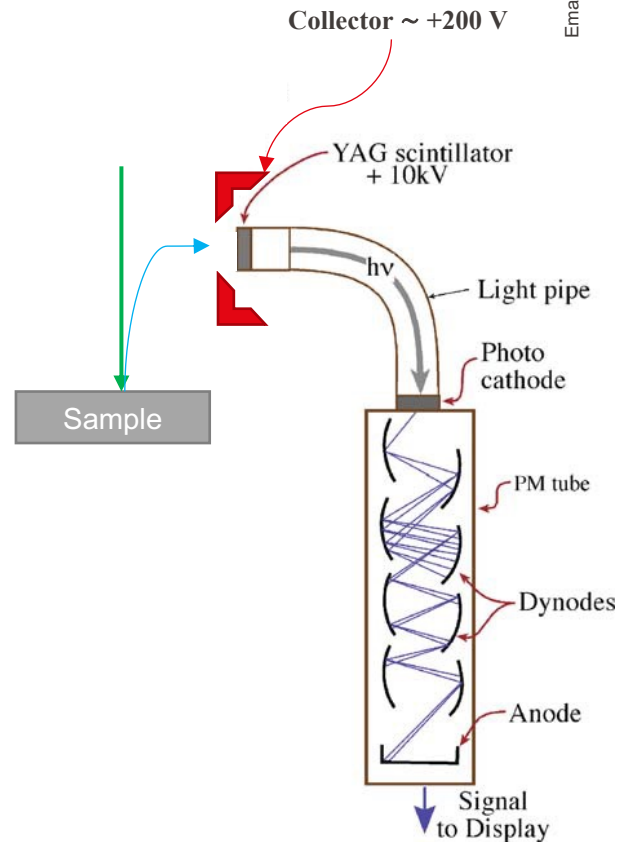

Electron detectors

Scintillator-Photomultiplier

- Faster a with lower noise level compared to the semiconductor detectors
 - low-intensity images and TV-rate images are easily displayed
- Not as robust as the semiconductor detector, being even more susceptible to radiation damage, particularly after long-time exposure to the beam.
- Scintillator-PM combination is substantially more expensive and bulky compared to semiconductor

How is an SEM image generated?

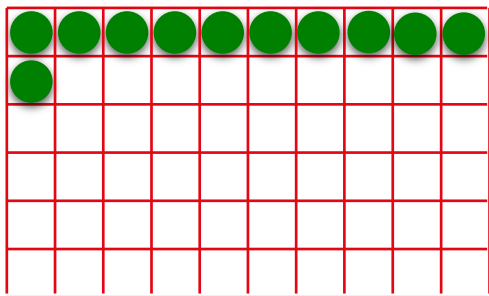

Beam locations on the specimen

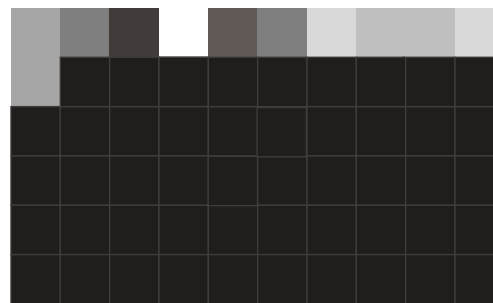

Area scanned on the screen

Information transfer $f(x,y,S)$

- Image formed step by step by the sequential scanning of the sample with the electron probe (using pair of deflector or scan coils, controlled by the scan generator)
- Monitor and scanning coils are synchronized
- Intensity of each pixel is proportional to signal received (collected SE/BSE electrons)
- When changing the magnification, we just change the raster size (no change in optics)

Magnification = Image size (e.g. display) / Raster size on the specimen

How is an SEM image generated?

Measure the size of the particle and calculate the magnification

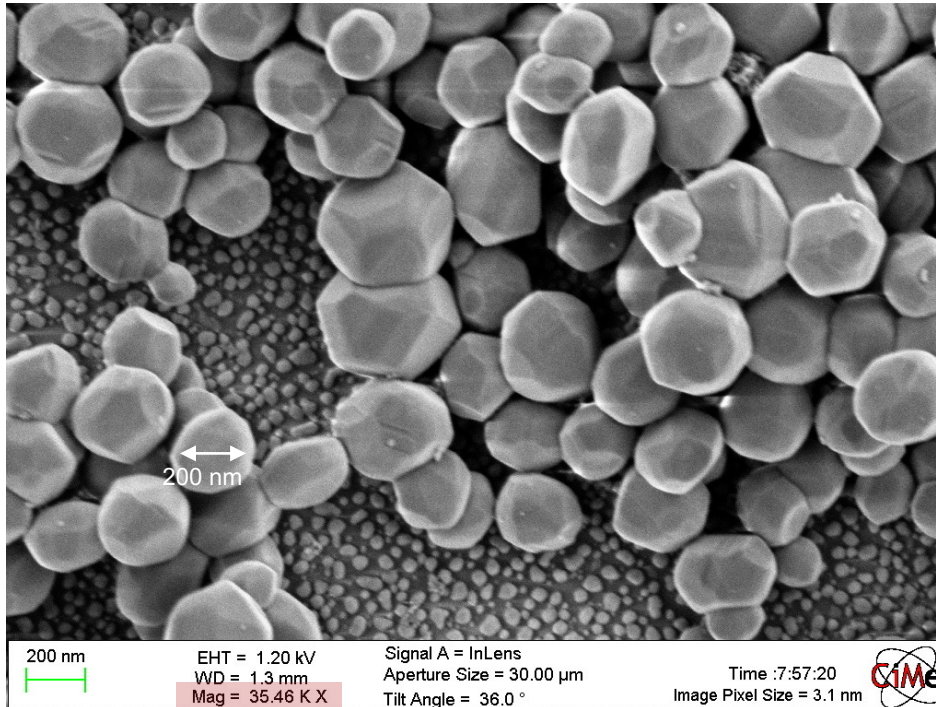

Assuming the size of the indicated particle on your screen is 2 cm, what is the magnification of the image?

- a) 35.46 kX
- b) 500 kX
- c) 100 kX
- d) 200 nm

How is an SEM image generated?

Measure the size of the particle and calculate the magnification

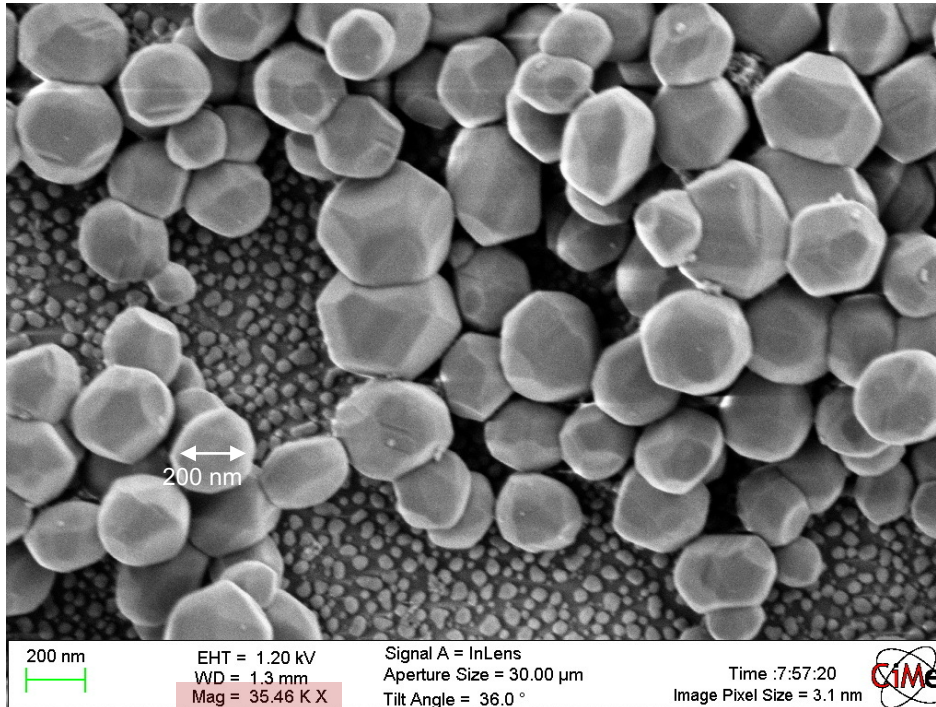

Assuming the size of the indicated particle on your screen is 2 cm, what is the magnification of the image?

- a) 35.46 kX
- b) 500 kX
- c) 100 kX
- d) 200 nm

Trust the scale bar and not the indicted magnification

How is an SEM image generated?

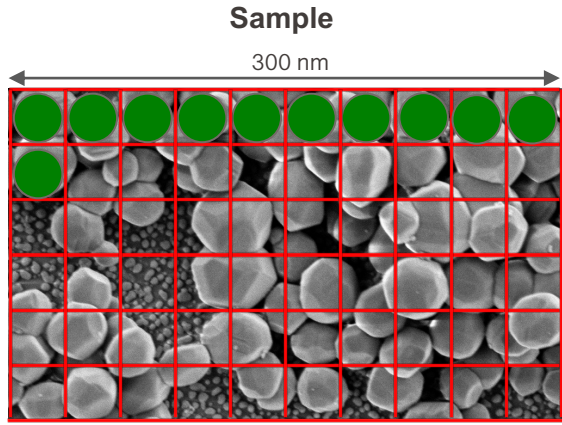

Scan step (i.e. pixel size) on the sample?

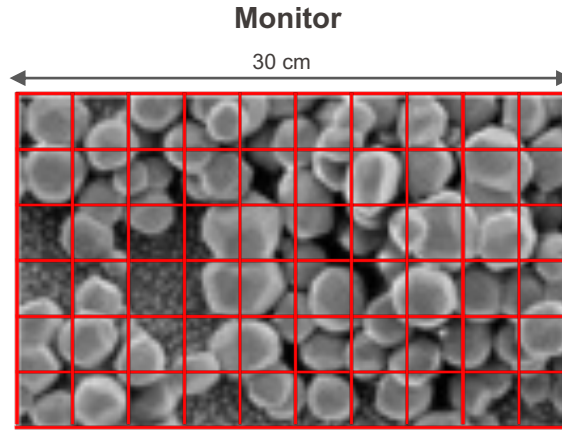

Pixel size on the screen?

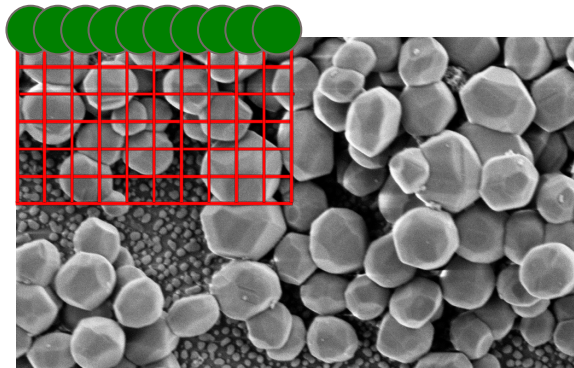

Scan step (i.e. pixel size) on the sample?

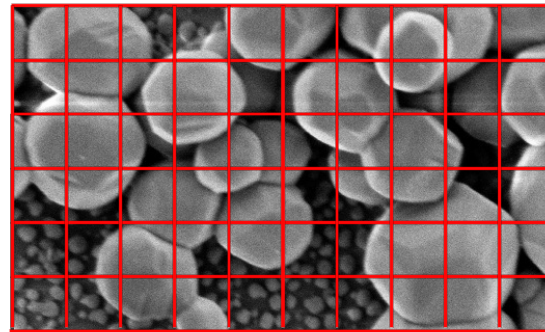

Pixel size on the screen?

How is an SEM image generated?

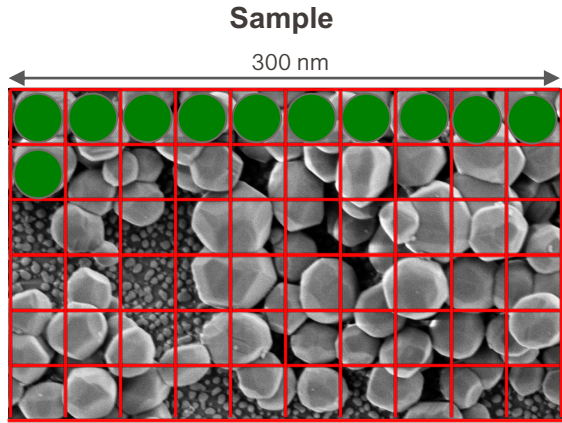

Scan step (i.e. pixel size) on the sample? = 30 nm

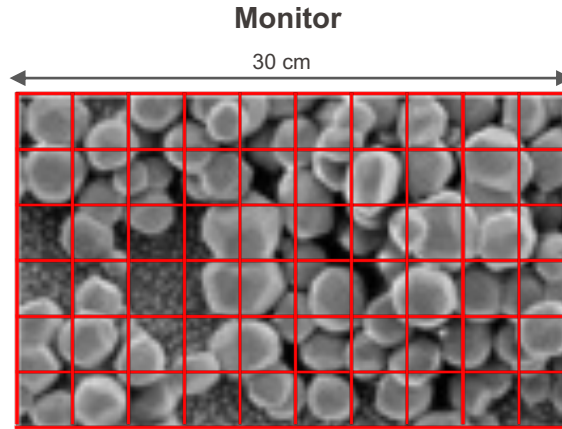

Pixel size on the screen? = 3 cm

$$\text{Magnification} = 3 \cdot 10^{-2} / 30 \cdot 10^{-9} = 1 \text{ MX}$$

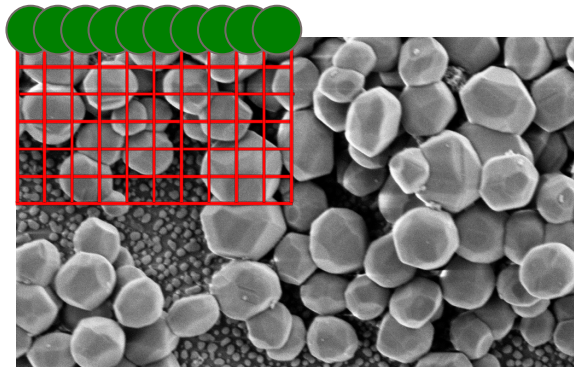

Scan step (i.e. pixel size) on the sample = 15 nm

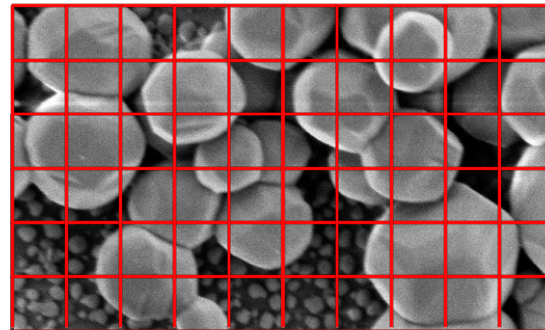

Pixel size on the screen? = 3 cm

$$\text{Magnification} = 3 \cdot 10^{-2} / 15 \cdot 10^{-9} = 2 \text{ MX}$$

What happens to resolution?

Quescussion

What is the best imaging condition to obtain a *high-quality* image of an object?

Think of photography!

- e.g. What is the object?
- ...
- ...
- ...
- ...

Parameters affecting Resolution (and Visibility)

- **Fundamental**

- Electron wavelength (beam energy) and diffraction limit: → Rayleigh criterion
- Aberrations: enlarges the probe size
 - Probe size (or spot size) means the diameter of the final beam at the surface of the specimen

- **Operational**

- Pixel size = scan step size
- Probe size (also defines probe current and affects visibility)
- Visibility:
 - Scan speed (i.e. dwell time) and “signal to noise ratio”
 - Contrast

- **Sample**

- Type and depth of emitted electrons signal
- System/Specimen stability → Challenges (charging, contamination, beam damage)

Resolution | Pixel size

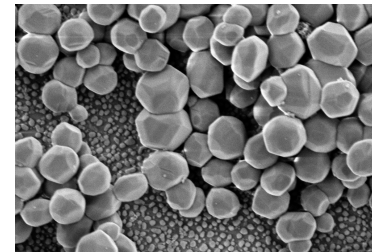
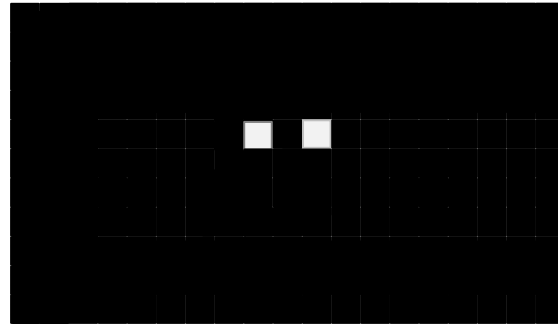
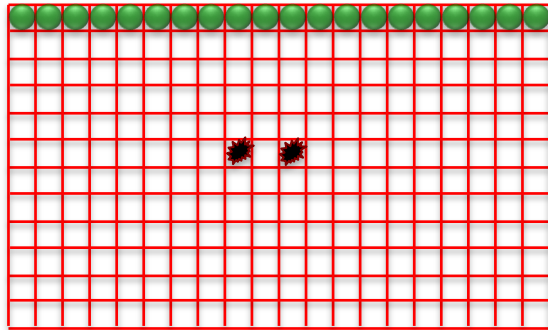
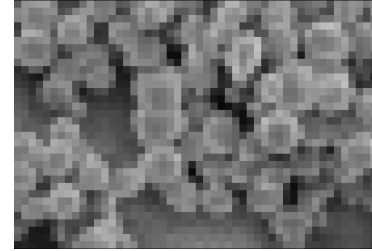
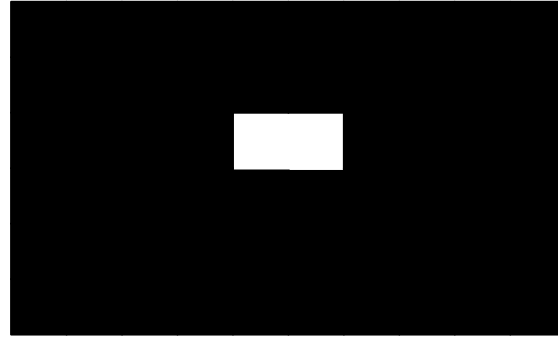
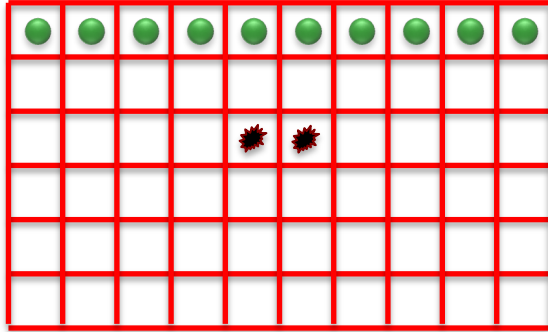

Nyquist sampling $(f) = d/2$, where “d” is the smallest object, or highest frequency

Thus, the imaging sample rate (or pixel) size should be roughly half the size of the smallest object you wish to observe; e.g. if you need 100 nm resolution, then scan every 50 nm (at least).

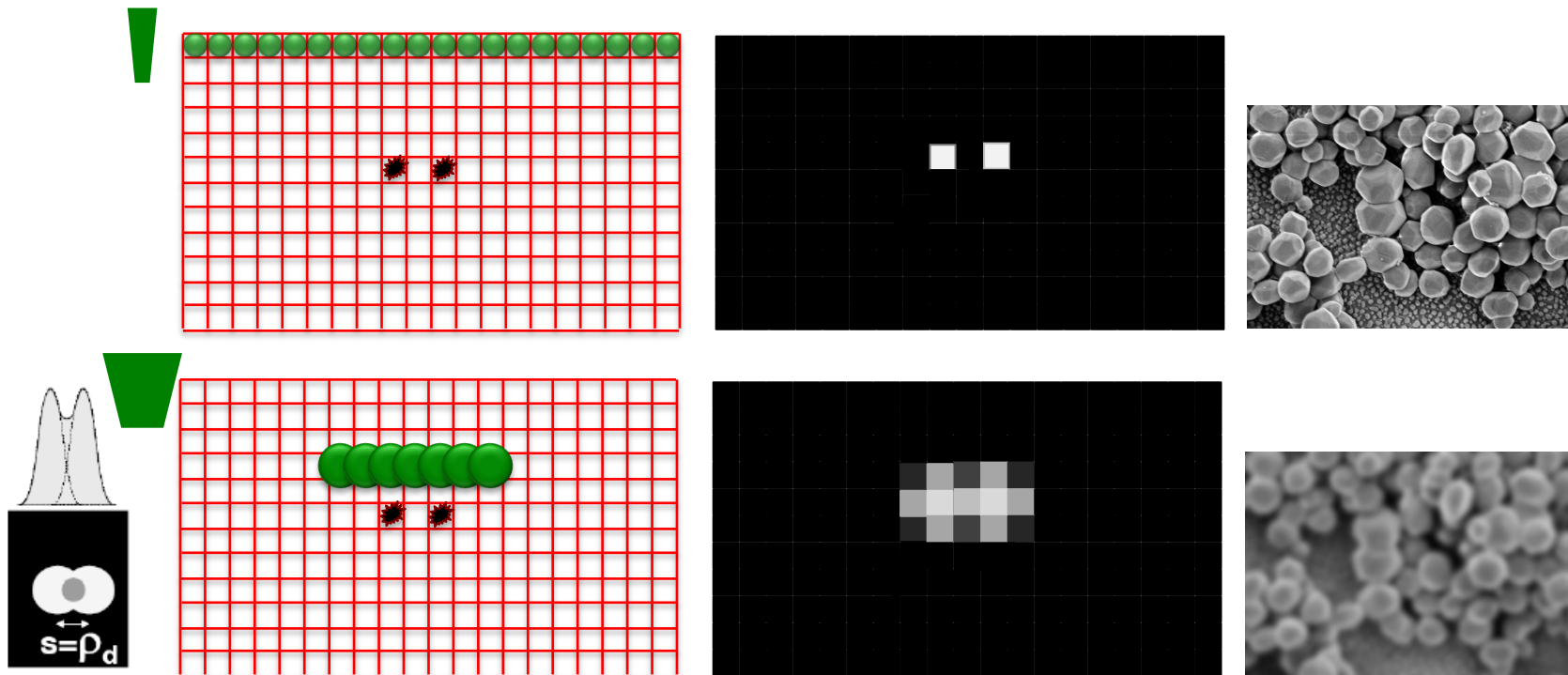

If a smaller probe has the potential to provide a higher resolution image, why is the smallest possible probe not always utilized?

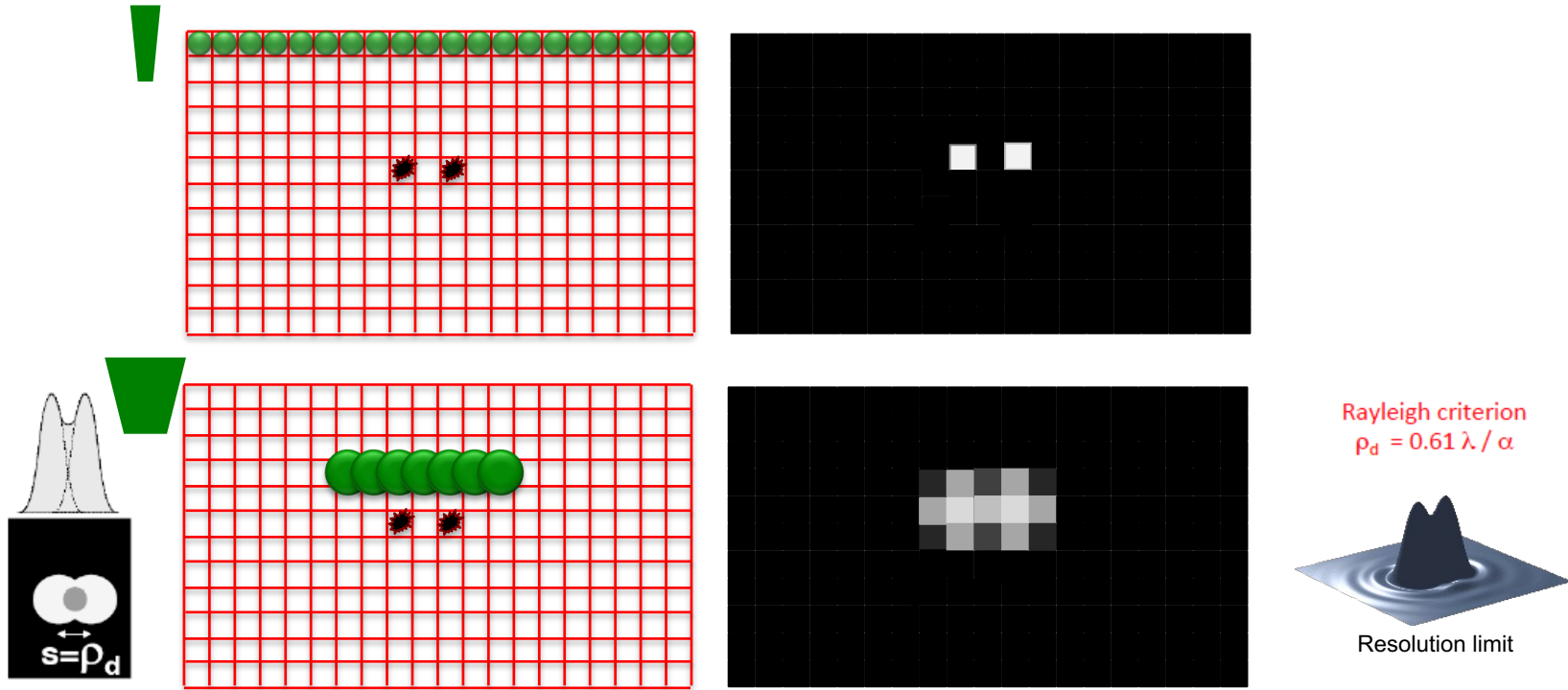

A small probe diameter comes with a decrease in probe current:
 means less electrons that impinges upon the specimen and generates the various imaging signals
→ Less signal to noise ratio: indirectly affects resolution (visibility issue)

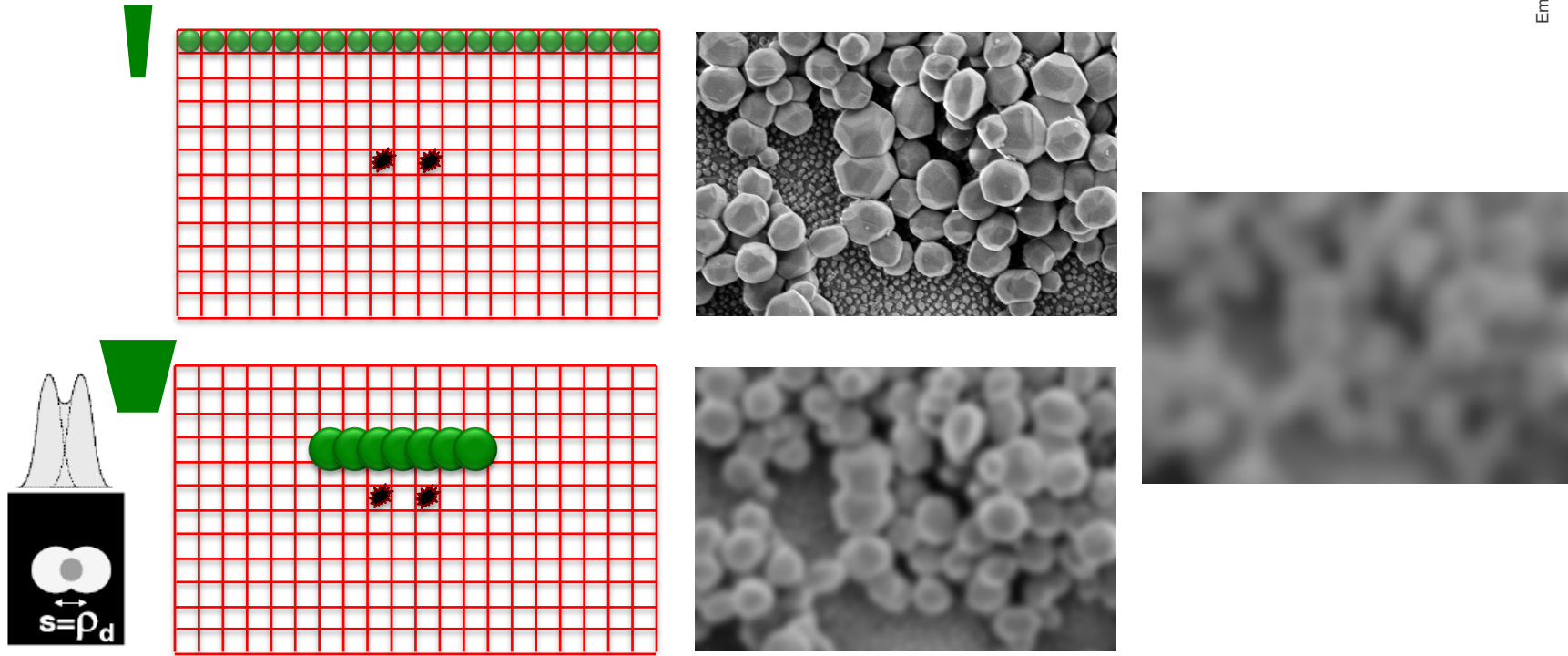

A small probe diameter comes with a decrease in probe current:
 means less electrons that impinges upon the specimen and generates the various imaging signals
→ Less signal to noise ratio: indirectly affects resolution (visibility issue)

Probe settings | Summary

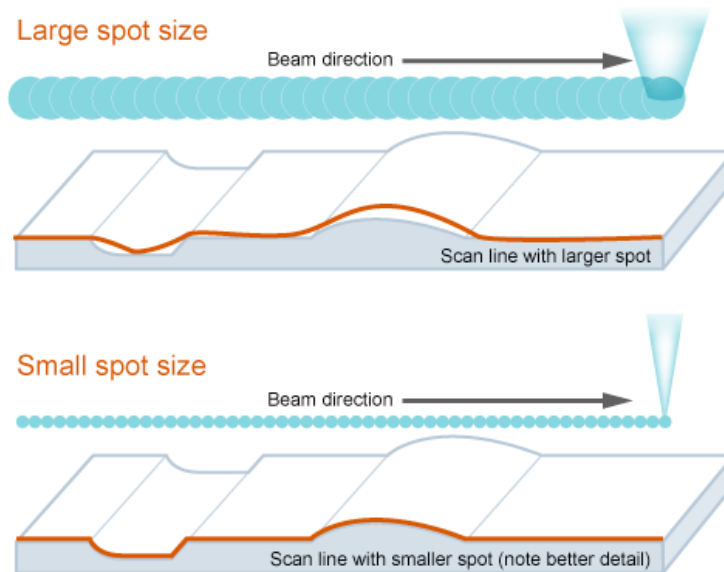
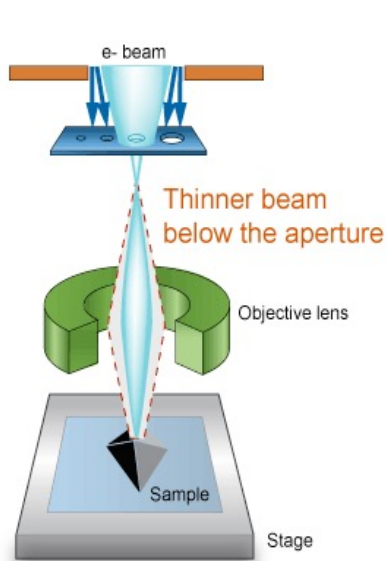

Aperture size (micron)	Probe current	Purpose
Small (e.g. 30 micron)	Low	High resolution; Low probe current (less signal); Large depth of field
Medium (e.g. 70 micron)	Medium	Usual observation
Large (e.g. 100 micron)	High	Low resolution but high probe current (more signal); Reduced depth of field, more Cs but smaller Airy-disk

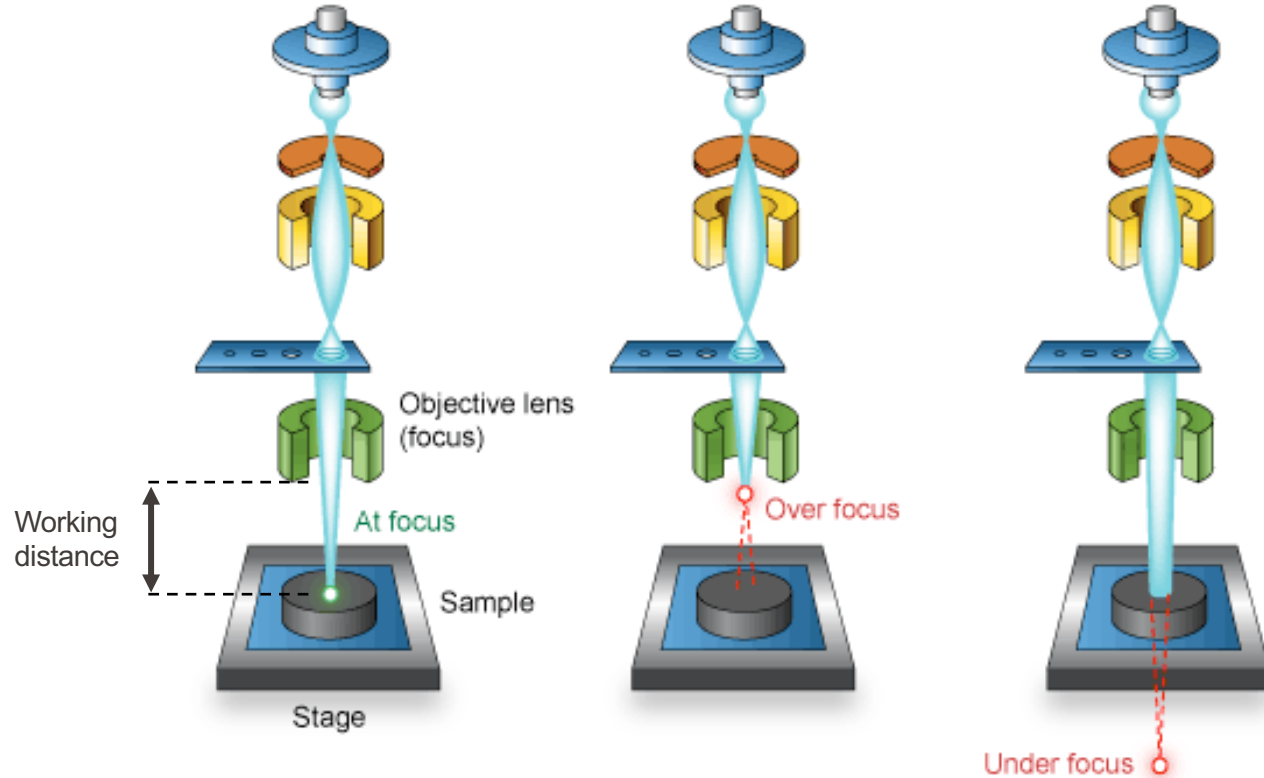

Best resolution when probe is focused on the sample surface

Probe settings | Depth of field

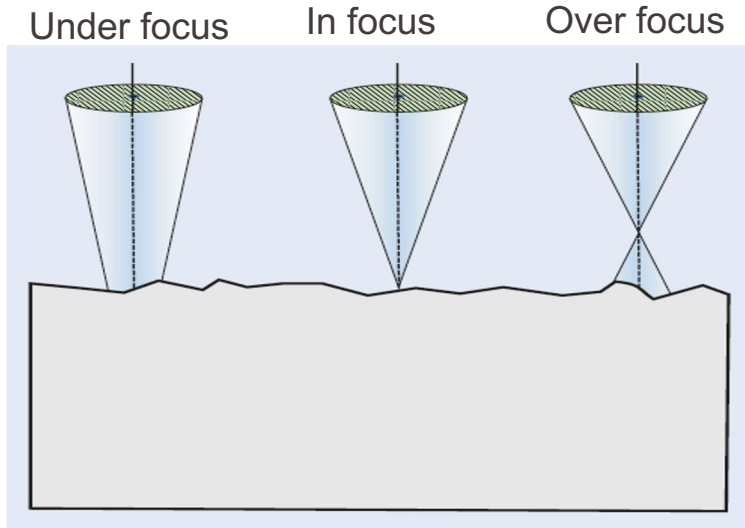

Best resolution when probe is focused on the sample surface

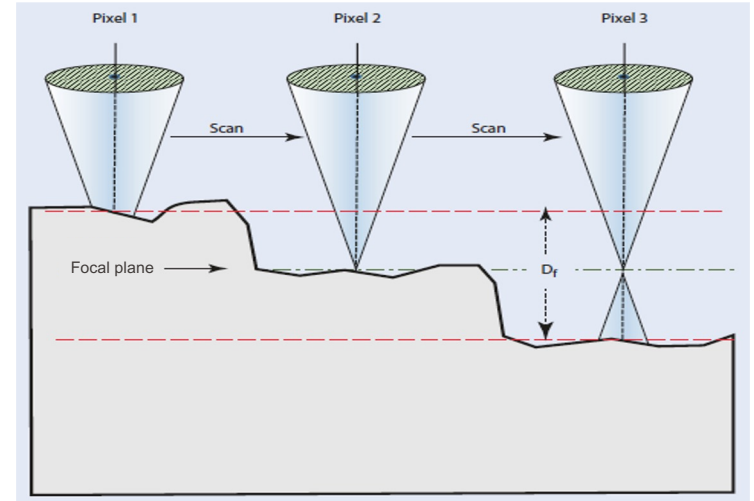

Lower resolution (focus) for regions of upper/lower depths

Depth of field

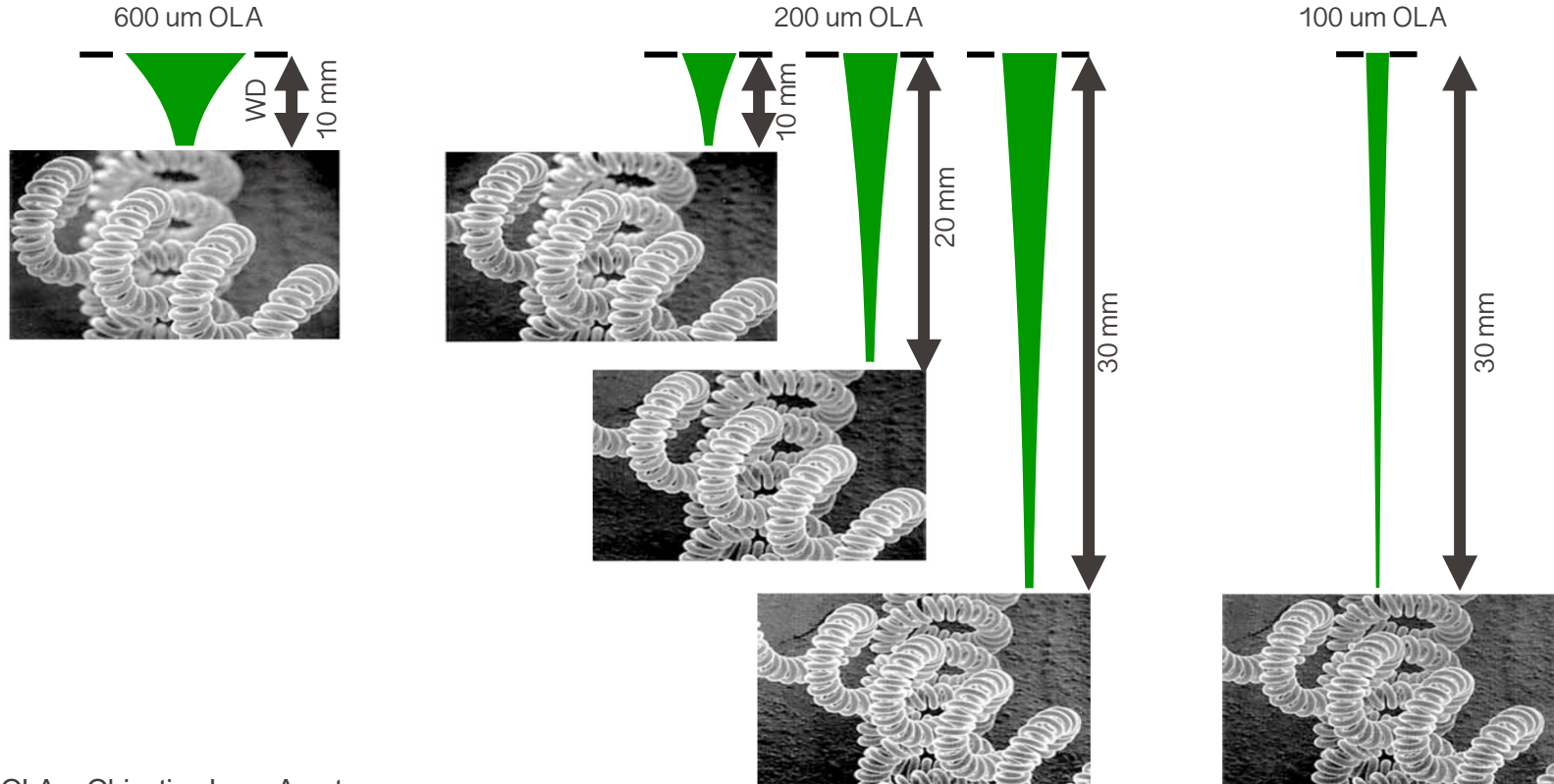

Depth of field

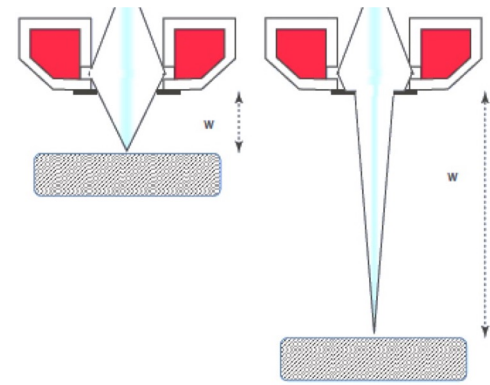
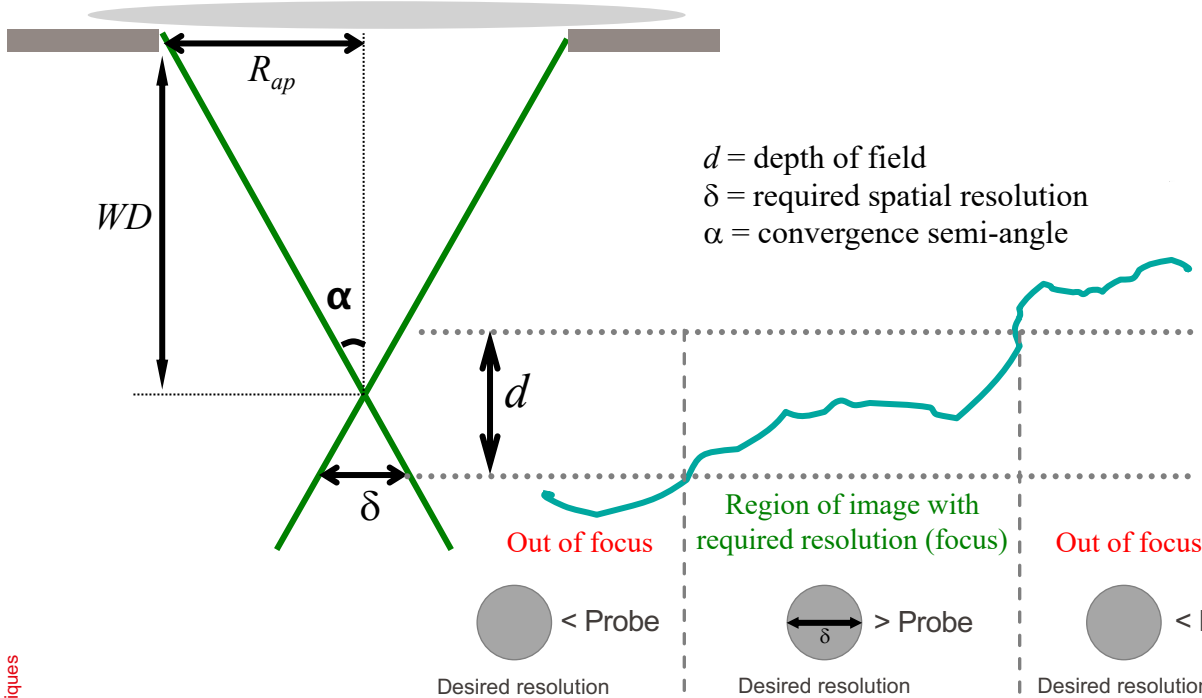

$$\tan \alpha = \frac{0.5\delta}{0.5d} = \frac{\delta}{d}$$

$$\tan \alpha = \frac{R_{ap}}{WD}$$

For small angles, $\tan(\alpha) = \alpha$

$$d = \delta \frac{WD}{R_{ap}}$$

Depth of field changes with convergence angle and working distance

Parameters affecting Resolution (and Visibility)

- **Fundamental**
 - Electron wavelength (beam energy) and diffraction limit: → Rayleigh criterion
 - Aberrations: enlarges the probe size
 - Probe size (or spot size) means the diameter of the final beam at the surface of the specimen
- **Operational**
 - Pixel size = scan step size
 - Probe size (also defines probe current and affects visibility)
 - Visibility:
 - Scan speed (i.e. dwell time) and “signal to noise ratio”
 - Contrast
- **Sample**
 - Type and depth of emitted electrons signal
 - System/Specimen stability → Challenges (charging, contamination, beam damage)

Visibility and “signal to noise” ratio

Features on a noisy background:

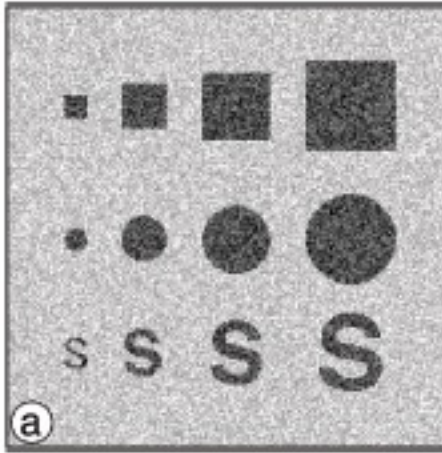

High signal to noise ratio

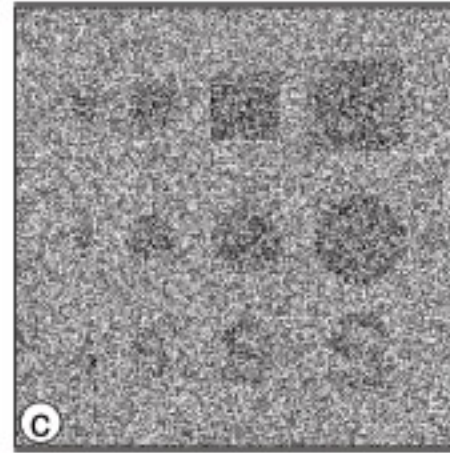
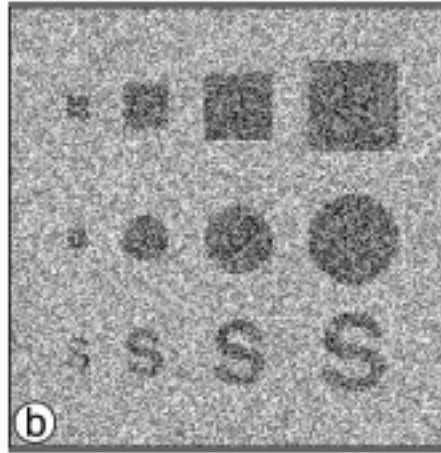

Low signal to noise ratio

How to improve signal to noise ratio?

Visibility and “signal to noise” ratio

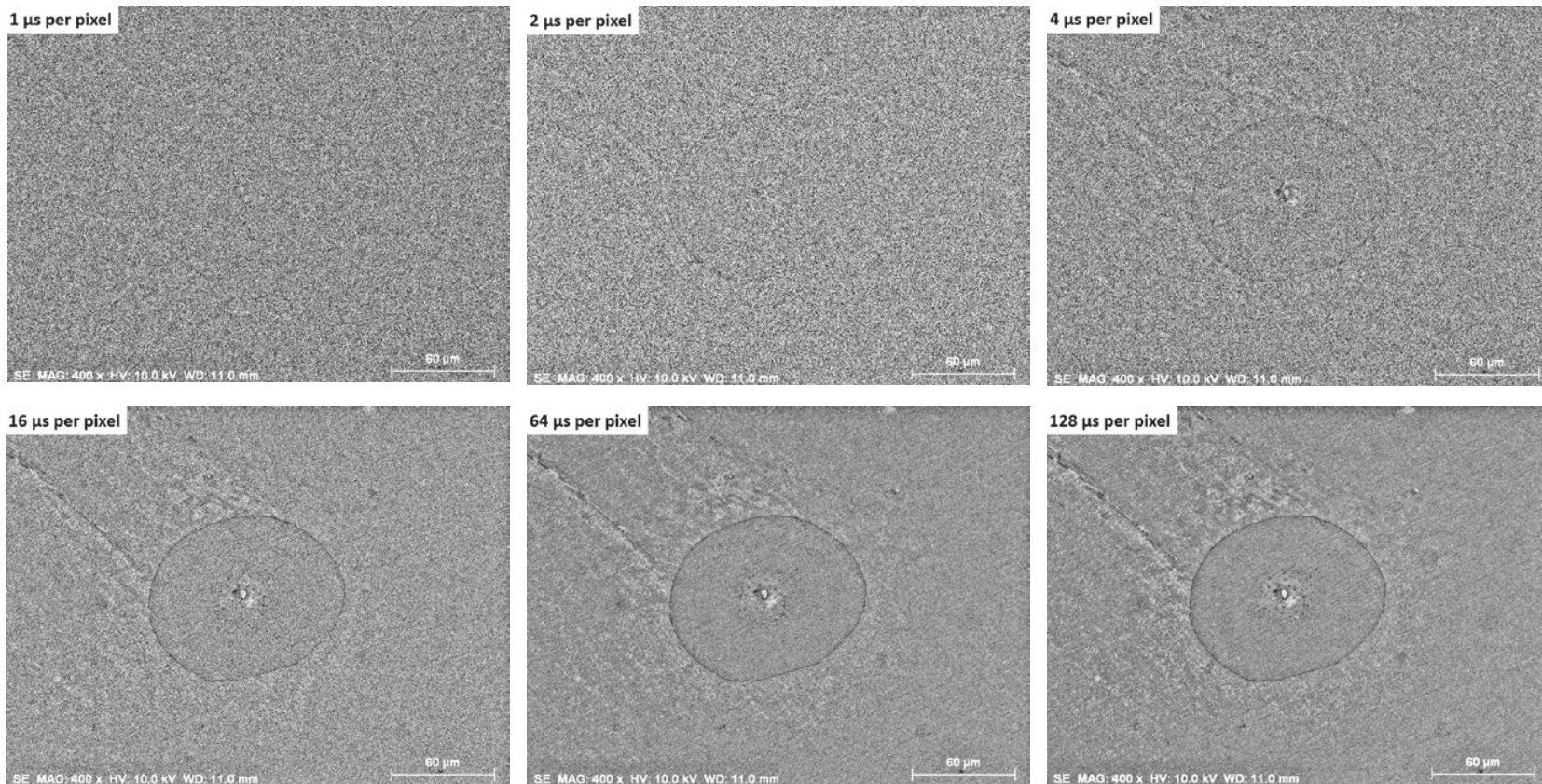

Threshold imaging visibility; image sequence with increasing pixel **dwell time** at constant beam current.
Sample: Inkjet deposited droplet on carbon planchet; ($E_0 = 10$ keV; Everhart–Thornley)

Effect of beam current

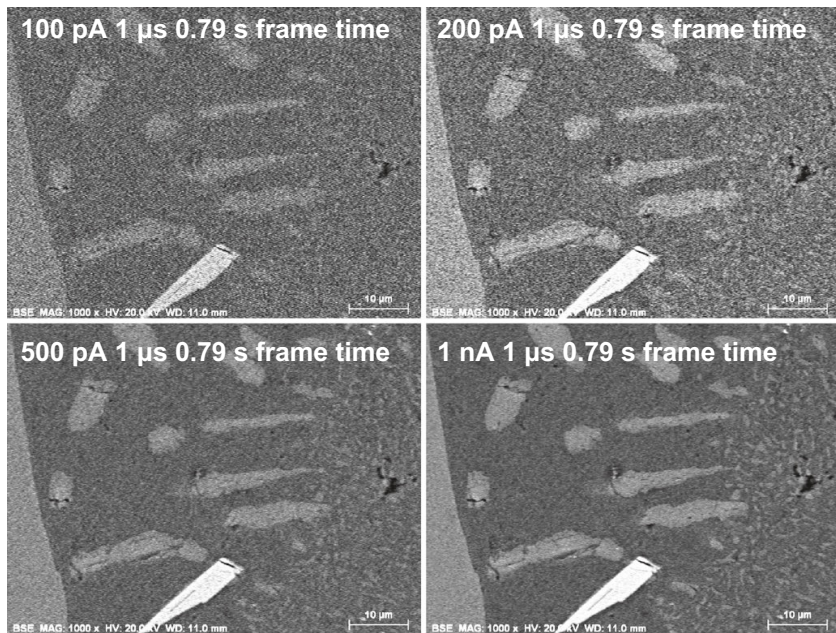

Possible charging or sample damage

Effect of pixel dwell time

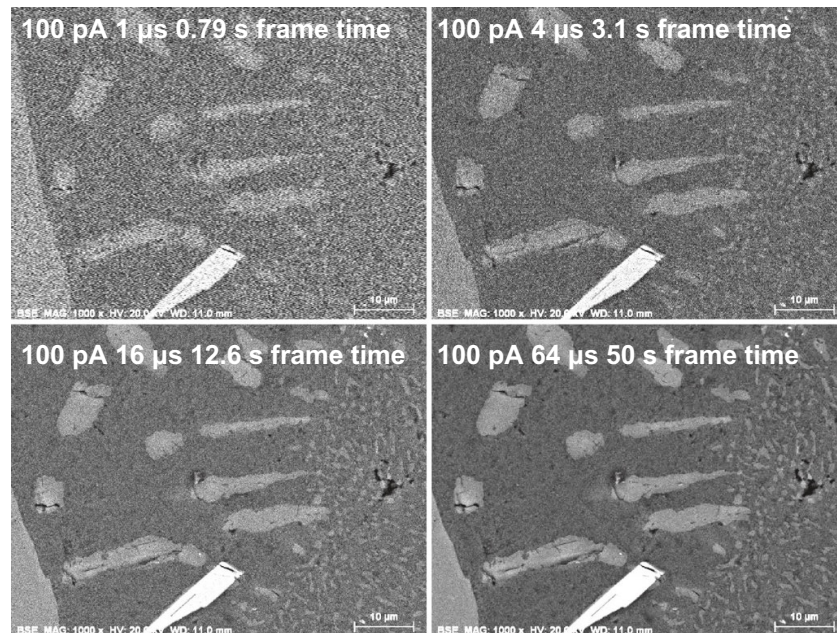

Sample drift may become the limiting factor

100% Intensity change

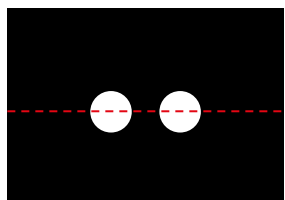

Particles with positive contrast



50% Intensity change

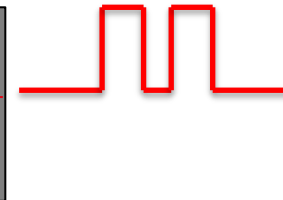
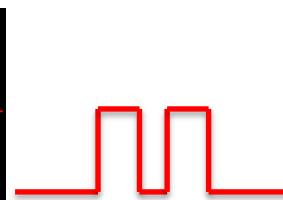
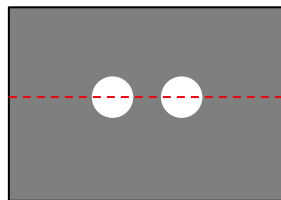
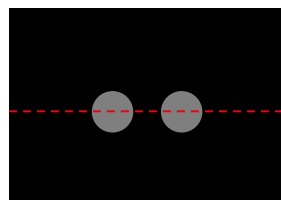

5% Intensity change

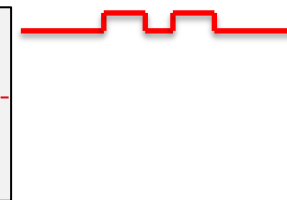
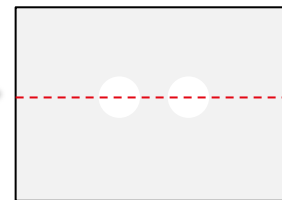
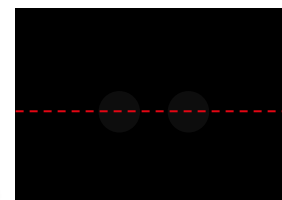

5.1% contrast

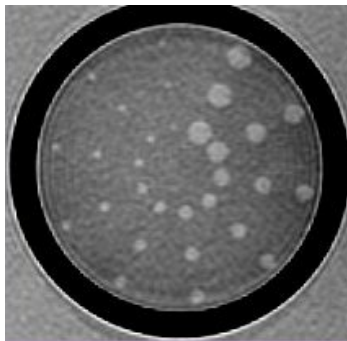

3.7% contrast

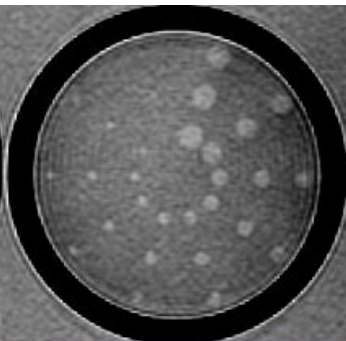

2.2% contrast

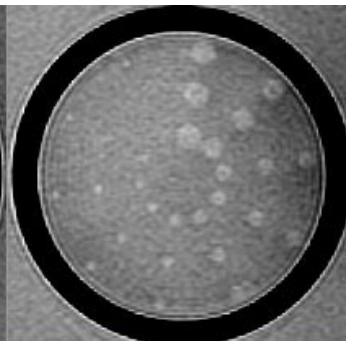

1% contrast

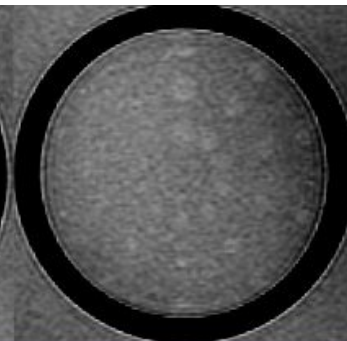

Visibility and contrast

Consider an 8 bit image with 2^8 gray levels

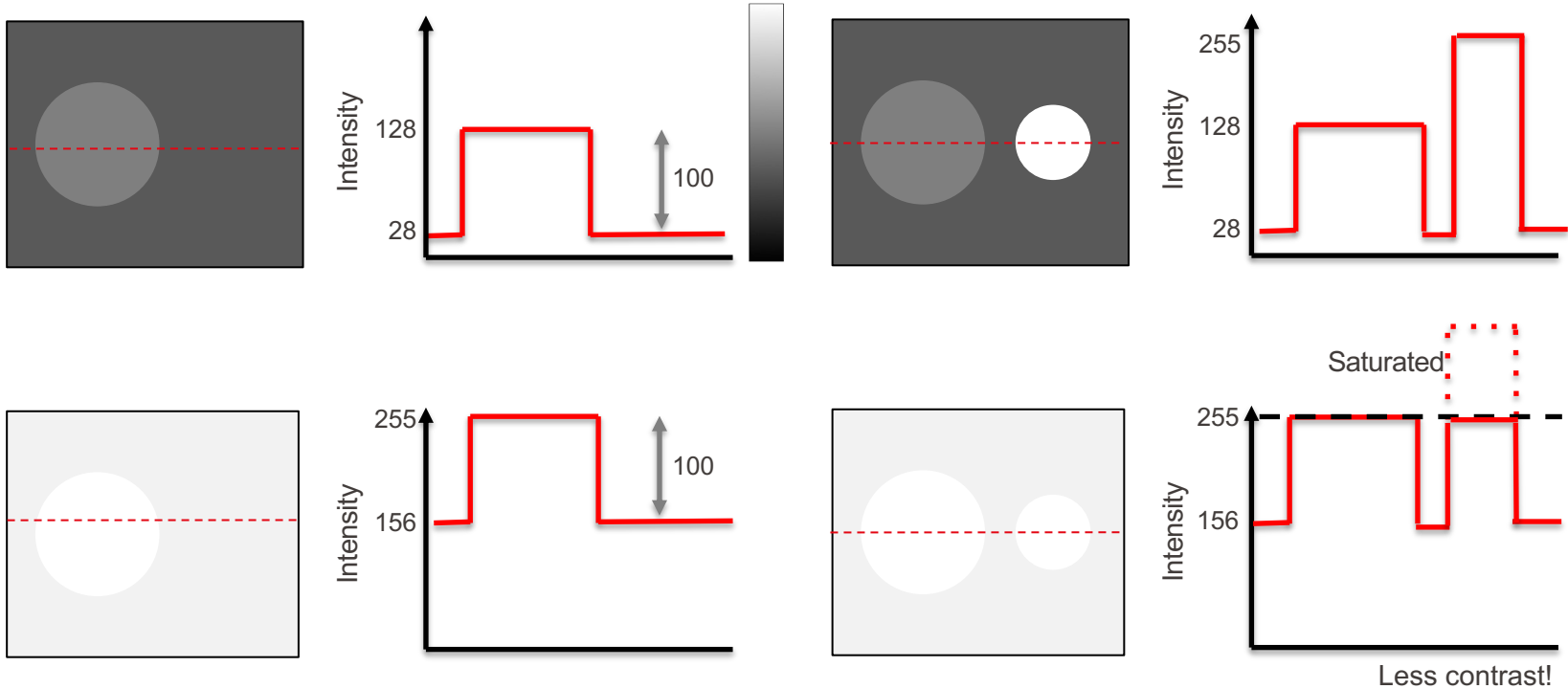

Do not throw away the information

If the detector's brightness and contrast are not properly adjusted, then it is not possible later to correct with image processing; i.e. over/under saturation problem

Parameters affecting Resolution (and Visibility)

- **Fundamental**
 - Electron wavelength (beam energy) and diffraction limit: → Rayleigh criterion
 - Aberrations: enlarges the probe size
 - Probe size (or spot size) means the diameter of the final beam at the surface of the specimen
- **Operational**
 - Pixel size = scan step size
 - Probe size (also defines probe current and affects visibility)
 - Visibility:
 - Scan speed (i.e. dwell time) and “signal to noise ratio”
 - Contrast
- **Sample**
 - Type and depth of emitted electrons signal
 - System/Specimen stability → Challenges (charging, contamination, beam damage)

- Type of signal:
 - Secondary and backscattered electrons
 - X-ray, Auger electrons, Cathodoluminescence, etc.

- Where the signal is generated
 - Depth
 - Spatial resolution

- How the signal is detected
 - Detector position/type → Signal selection
 - Energy/type selection → Affects spatial resolutions

Incident electrons interaction with the sample produces:

Electron signals:

Secondary electrons SE

Electrons ejected from the conduction or valence bands of the target atom: low energy $\approx 5\text{-}50\text{ eV}$
 Free electrons: not associated with a specific atom and contain no specific elemental information
 Can only escape if they are near the specimen surface \rightarrow **Topography**

Backscattered electrons BSE

Incident electrons that scatter (elastically or inelastically) and leave the sample
 Energy range from 50 eV to an energy close to initial energy eV_0
 Most backscattered electrons retain at least 50% of the incident beam energy.
 Yield depends on the atomic number \rightarrow **Z-contrast**

Auger electrons

If the electrons are ejected from an inner shell by the energy released when an ionized atom returns to the ground state, then these SEs are called Auger electrons.
 Ejected electrons with an energy characteristic of target elements \rightarrow **surface spectroscopy**
 Not detected in conventional SEM

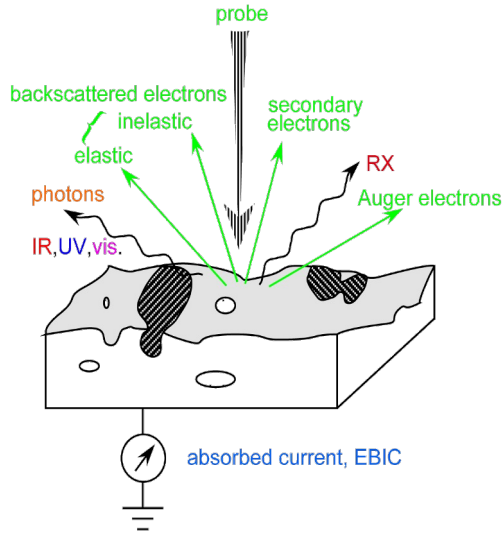

Incident electrons interaction with the sample produces:

Other signals:

Electromagnetic radiations:

- X-rays with continuous energy, resulting from deceleration of incident electrons ("Bremsstrahlung" or "braking radiation")
- Characteristic X-rays with a distinct energy associated to the target atoms.
- Cathodoluminescence: Visible radiation mainly emitted by insulating or semi-conducting materials.

Others:

- Absorbed current, electron-holes pairs creation, EBIC
- Plasmon
- Sample heating (phonons)
- Radiation damages: chemical bonding break, atomic displacement (*knock-on*) damage

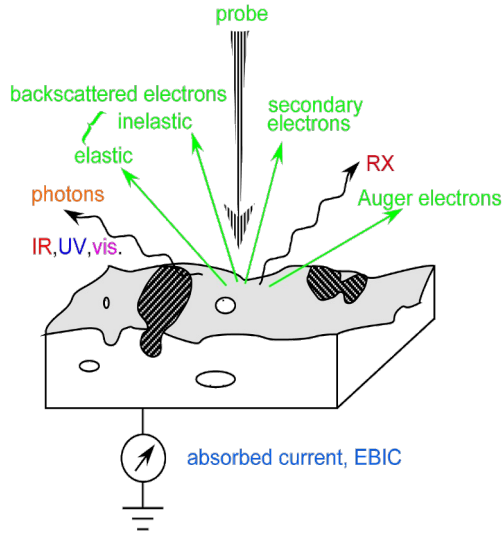

Energy spectrum of electrons leaving the sample

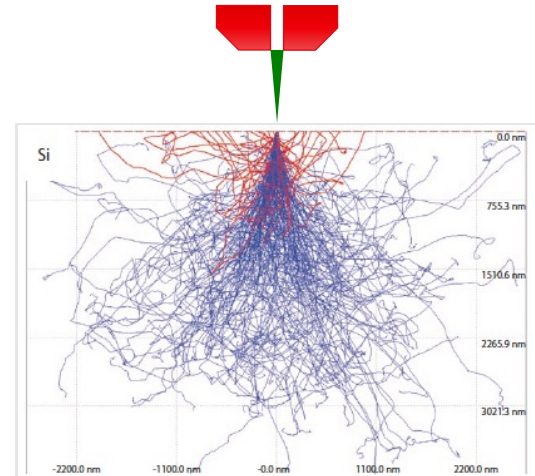
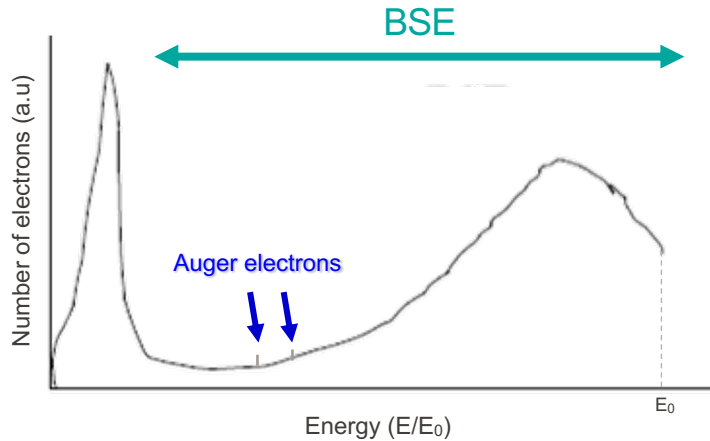

$$\text{BSE: } 50 \text{ eV} < E_{\text{BSE}} < E_0$$

What is the source of the prominent peak in the low-energy region of the spectrum?

BSE energy range: BSEs follow trajectories which involve very different distances of travel in the specimen before escaping. The energy range for BSEs is thus wide (from 50 eV to that of the incident beams energy). The majority of BSEs, however, retain at least 50% of the incident beam energy (E_0).

Generally speaking, higher atomic number elements produce a greater number of higher energy BSEs and their energy peak at the higher end is better defined.

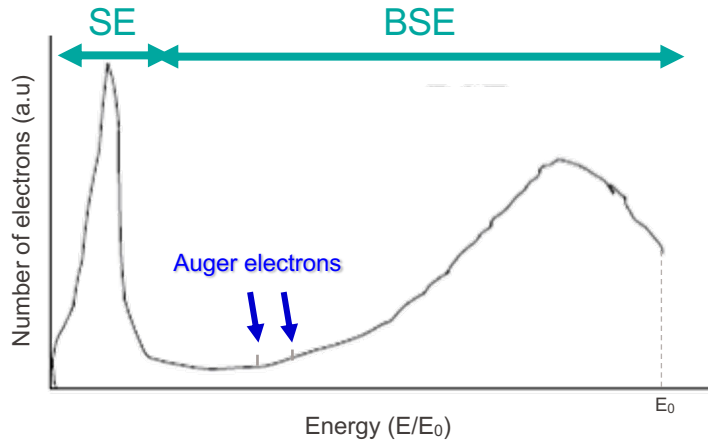
Energy spectrum of electrons leaving the sample

$$\text{BSE: } 50 \text{ eV} < E_{\text{BSE}} < E_0$$

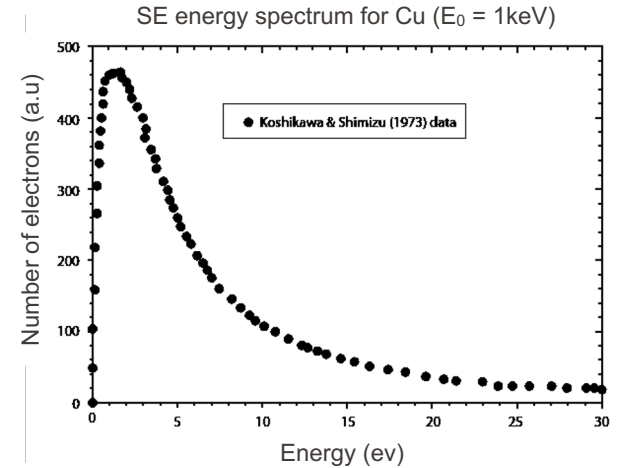

$$\text{SE: } E_{\text{se}} < 50 \text{ eV}$$

The most important characteristic of SE is their extremely low kinetic energy, as the transfer of kinetic energy from the primary electron to the SE is relatively small. After ejection, the SE must propagate through the specimen while undergoing inelastic scattering, which further decreases their kinetic energy.

- SE are generated along the complete trajectory of the beam electron within the specimen, but only a very small fraction of SE can reach the surface and escape → SE is mainly a Surface signal

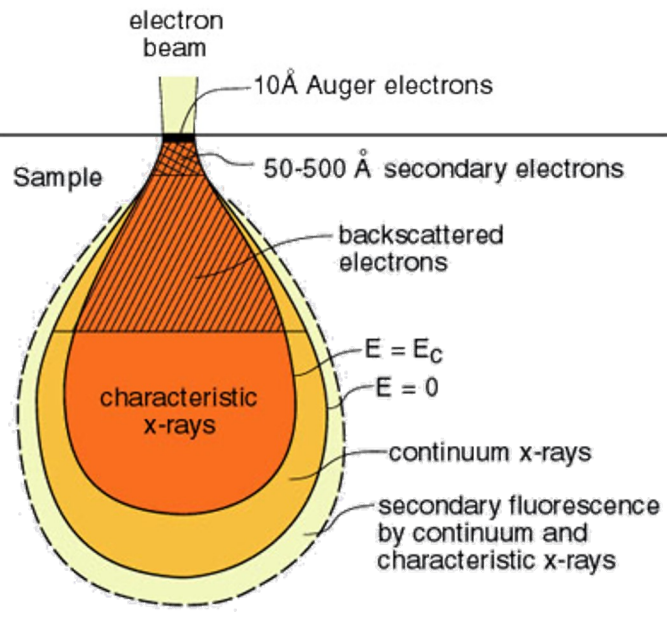

Surface signals:

- Secondary electrons (topography)
- Auger electrons (electronic states, chemistry)

Sub-surface signals:

- Backscattered electron (Z contrast, crystallographic information)
- Characteristic X-ray (compositional information)
- Secondary fluorescence (Cathodoluminescence, band-gap)

Spatial resolution depends on the size of the interaction volume

Interaction volume differs with material, beam energy (depth and widening), and spot size (widening).
Monte-Carlo simulations can be used to determine the interaction volume, etc.

SEM signals | Where they come from

The higher the beam energy,

- The longer the scattering MFP, so the less the rate of energy loss with distance travelled
Electrons enter the specimen with more energy and lose it at lower rate.
- The trajectories near the surface become straighter,

So, the more the penetration depth (i.e. larger interaction volume)

Cumulative effects of multiple elastic scatterings cause some electrons to propagate back towards the surface, thus widening the interaction volume.

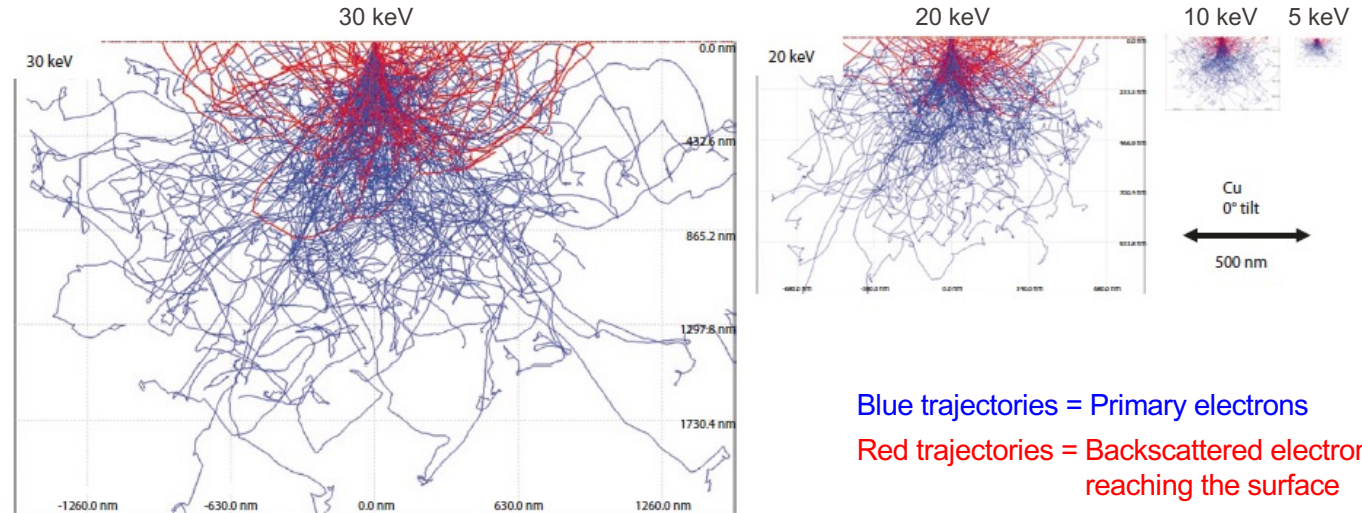
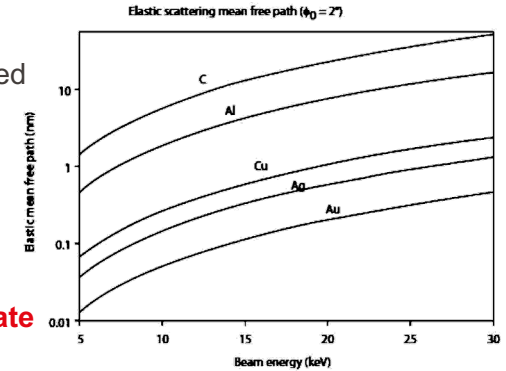

Blue trajectories = Primary electrons
Red trajectories = Backscattered electrons reaching the surface

Effect of the accelerating voltage (beam energy) on penetration depth and signal

Example 1: Carbon foil on top of copper grid

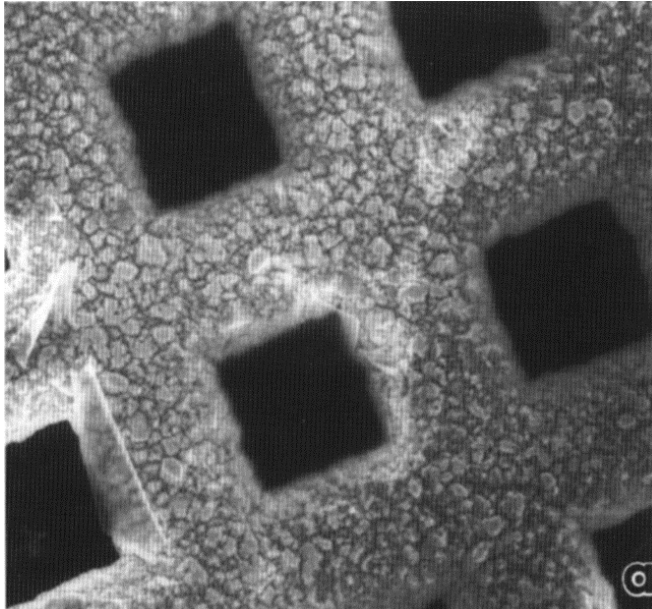

20 kV:

Strong penetration:

It reveals the copper grid under the C film via the electron backscattering, but the structure of the film itself is hidden

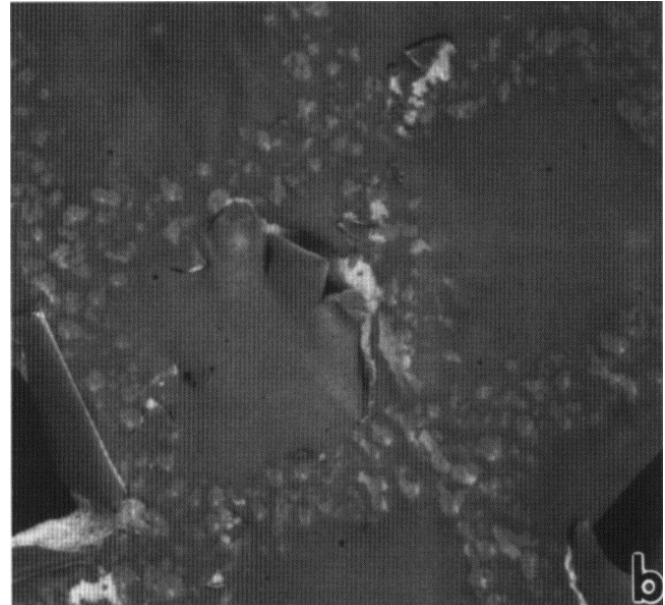

2 kV:

Low penetration,

Only a few electrons reach the copper grid and most of the signal is produced in the C film. The C film and its defects become visible

Effect of the accelerating voltage (beam energy) on penetration depth and signal

Example 2: Top surface images of a TiO₂/perovskite/FA-CN device

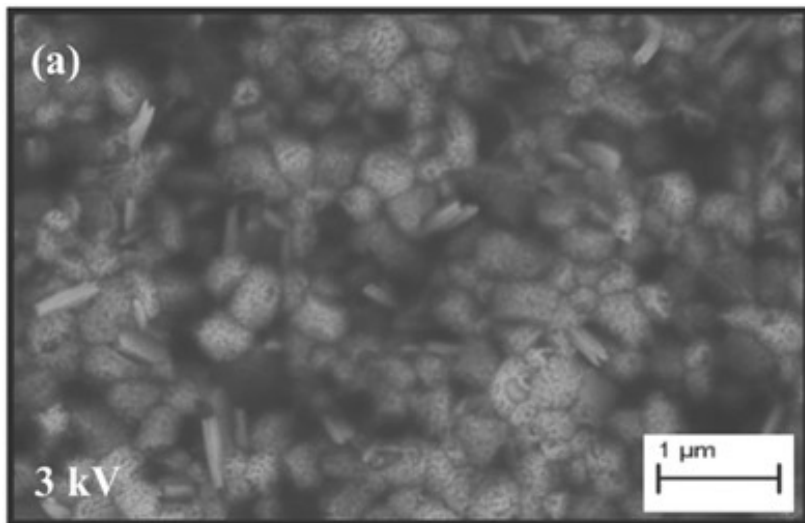

3 kV:

It reveals the perovskite grains, but the structure of the covering HTM layer (FA-CN) is not visible.

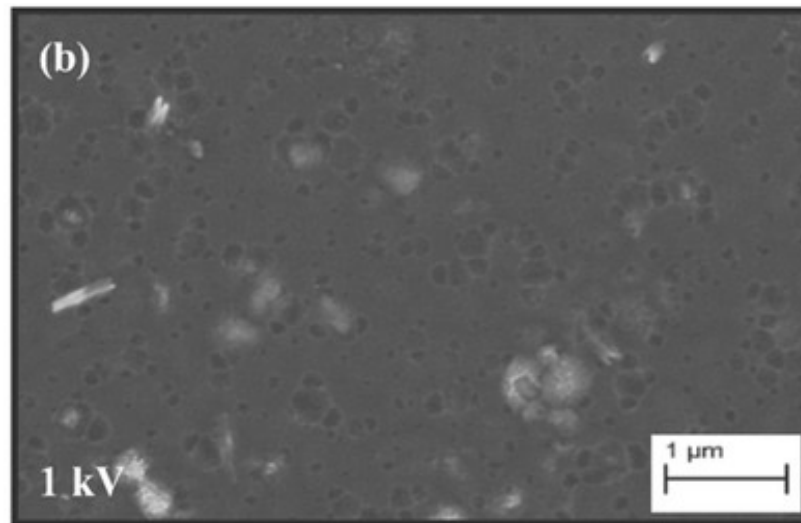

1 kV:

Only a few electrons reach the perovskite layer and most of the signal is produced in the HTM layer. The HTM layer is visible

Effect of the accelerating voltage (beam energy) on penetration depth and signal

Example 3: BSE images at various incident beam energies of a semiconductor device consisting of silicon and various metallization layers at different depths

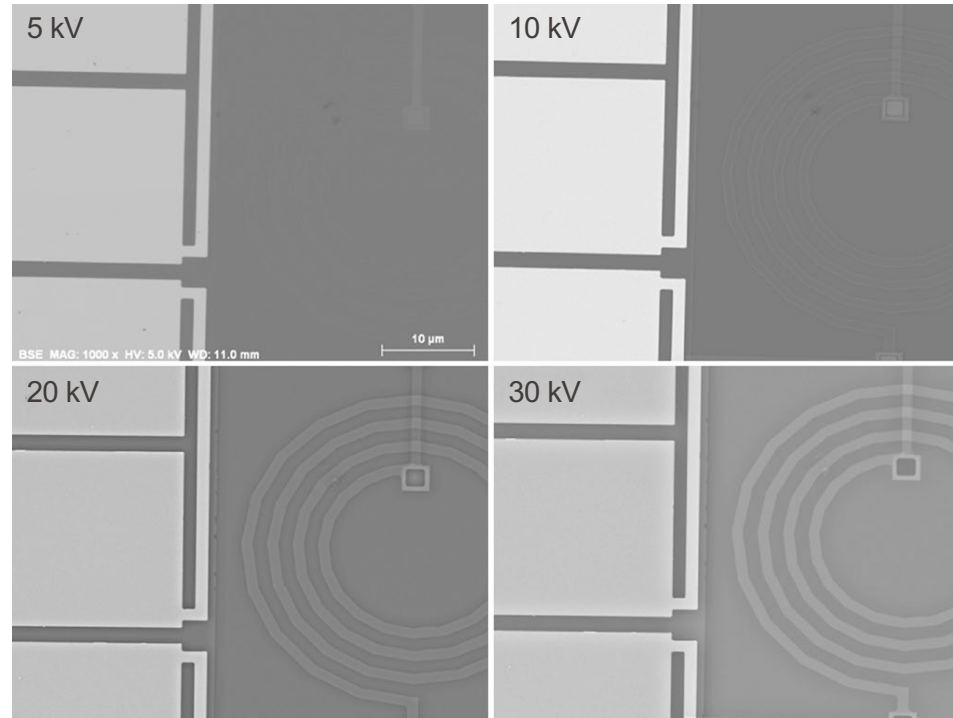

SEM signals | Where they come from

The higher the atomic number “Z”,

- the more the probability for scattering (elastic and inelastic) (i.e. shorter scattering mean free path)

So, the shorter the penetration depth (i.e. smaller interaction volume).

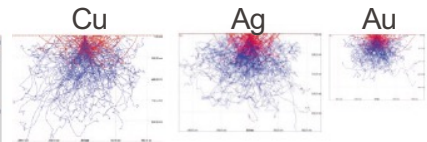
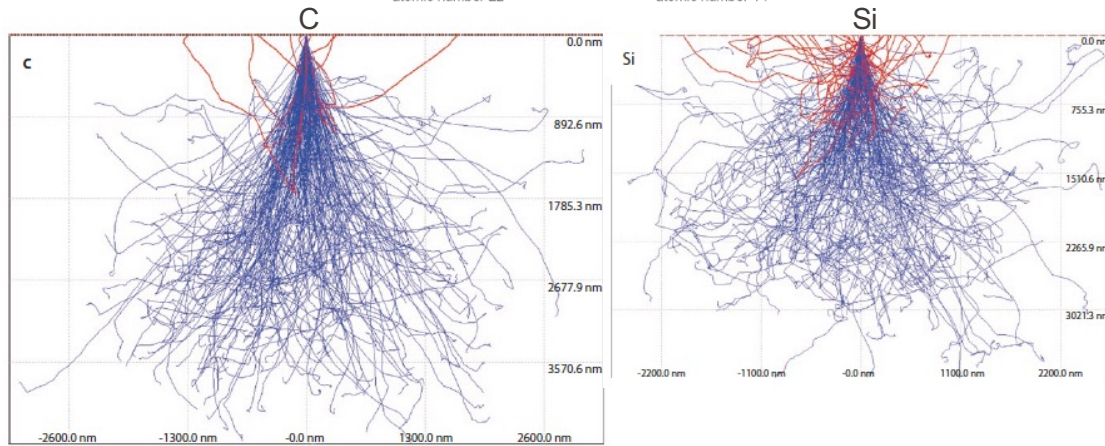
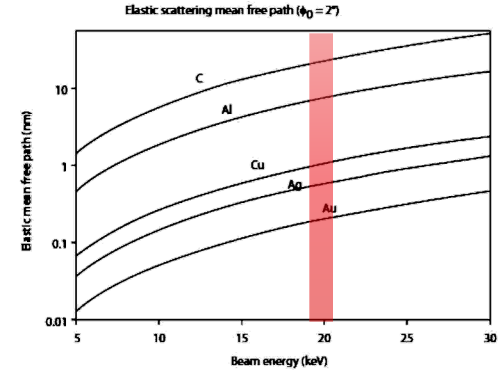
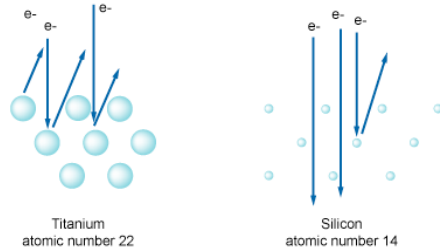

$E_0 = 20 \text{ keV}$
 0° tilt



Blue trajectories = Primary electrons
 Red trajectories = Backscattered electrons reaching the surface

SEM signals | Where they come from

The higher the atomic number “Z”,

- the more the probability for scattering (elastic and inelastic) (i.e. shorter scattering mean free path)

So, the shorter the penetration depth (i.e. smaller interaction volume).

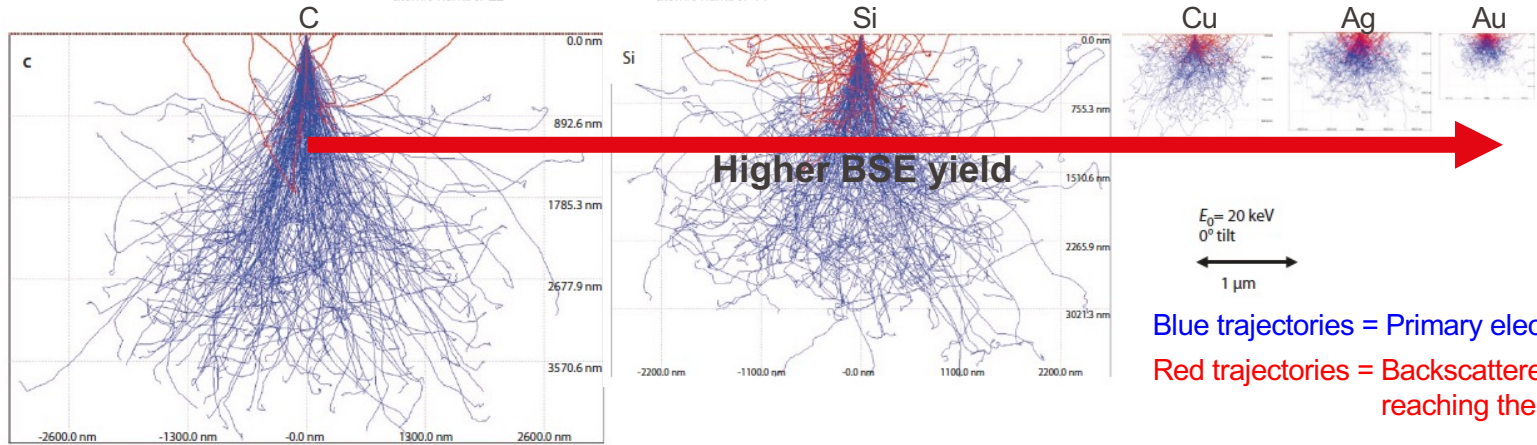
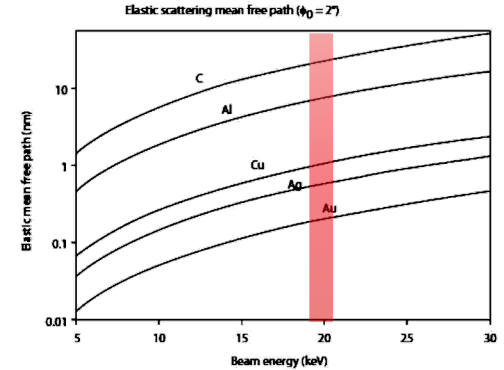
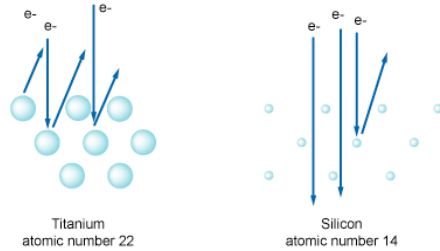

Blue trajectories = Primary electrons
Red trajectories = Backscattered electrons reaching the surface

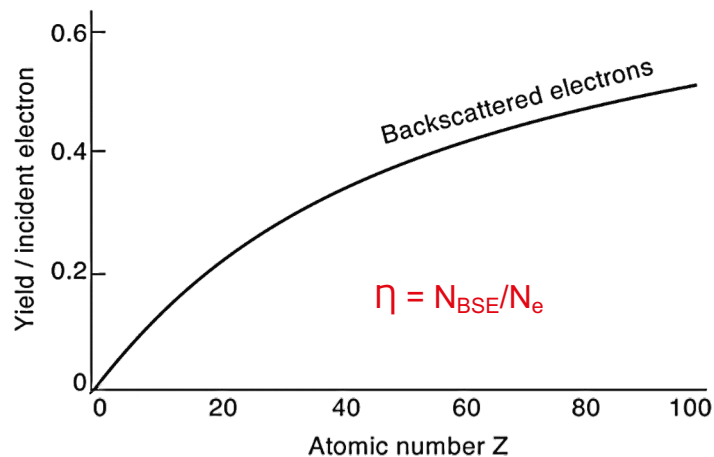
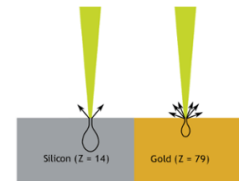

BSE yield η increases with “Z”

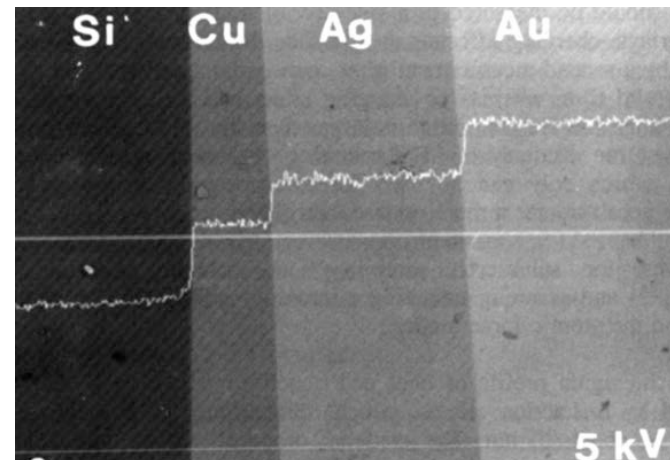

- η shows a monotonic increase with atomic number: Areas of the specimen composed of higher atomic number elements emit more backscatter signal and thus appear brighter in the image.

This relationship forms the basis of atomic number (Z) contrast imaging with BSE.

- Z contrast is relatively stronger at lower atomic numbers (see the slope of the line).

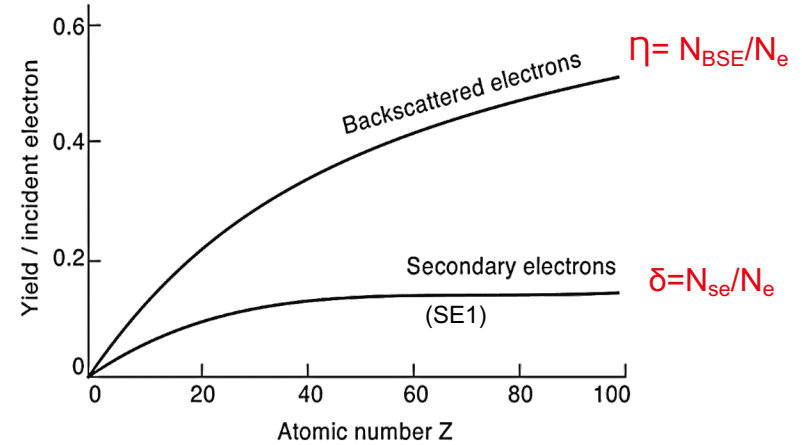
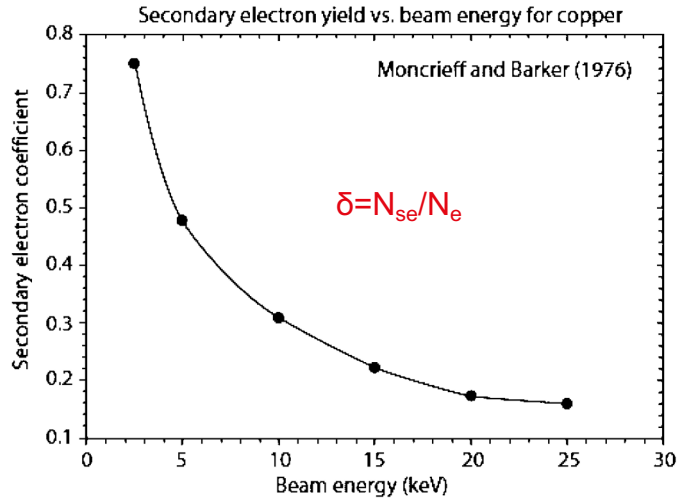

There is a general rise in δ as the beam energy is decreased, primarily due to the reduction in the interaction volume.

δ is generally regarded as being independent of Z. If there is any (still a matter of debate) then it is very small.

BSE yield increases monotonically with the “Z” of material, and SE yield depends mainly on the beam energy

Example1 : Scanning electron micrographs of Mo-Cu weld interface

SE image

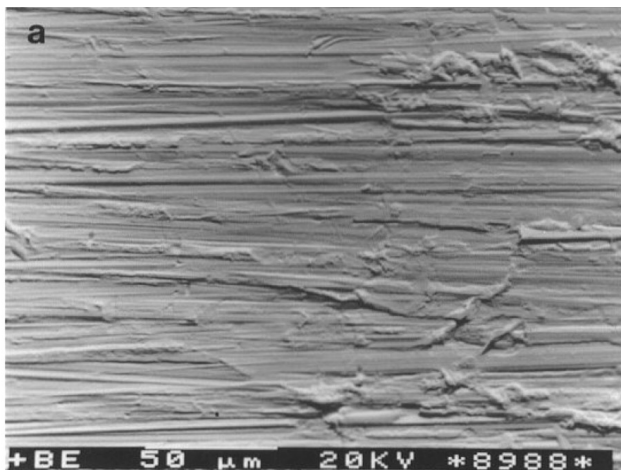

BSE image

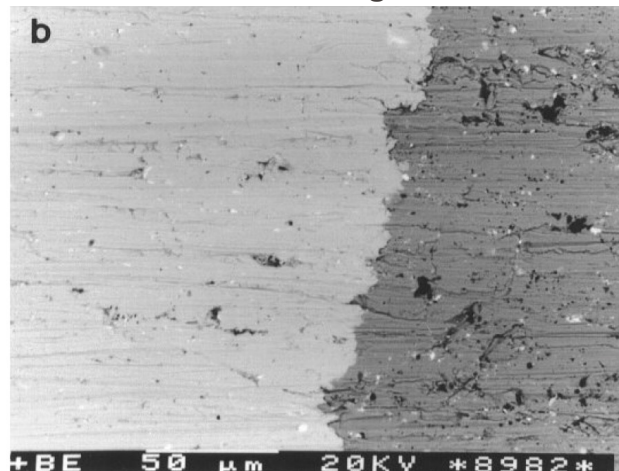

SE have low energies (5-50eV), and thus are **emitted** only from surface and possess information about topographical features.

BSE emission depends on “Z”, thus intensity in the BSE images scales with atomic number and depends on local composition

Example2 : Ferritic stainless substrate coated with a porous MnCo_2O_4

SE image

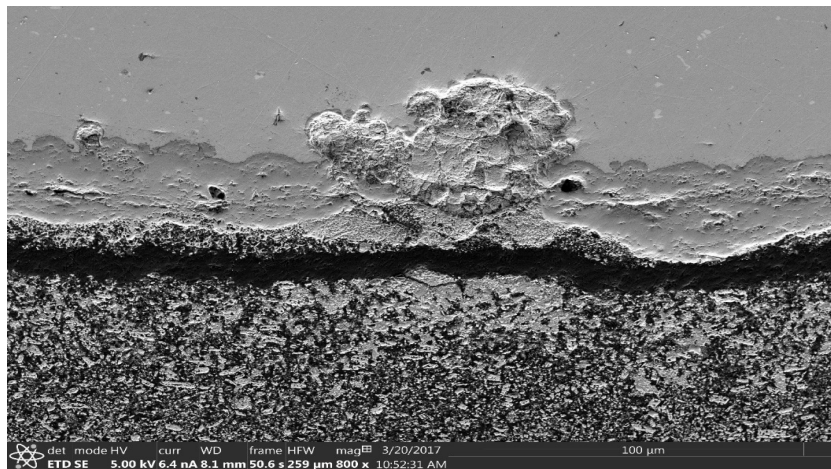

BSE image

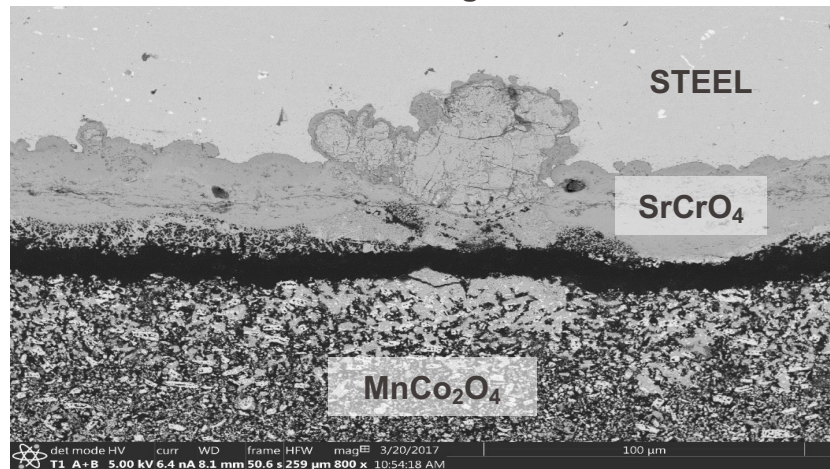

SE have low energies (5-50eV), and thus are **emitted** only from surface and possess information about topographical features.

BSE emission depends on “Z”, thus intensity in the BSE images scales with atomic number and depends on local composition

Example 3: Plan-views of GaN nanowires with InGaN quantum wells
Images acquired at 2 kV

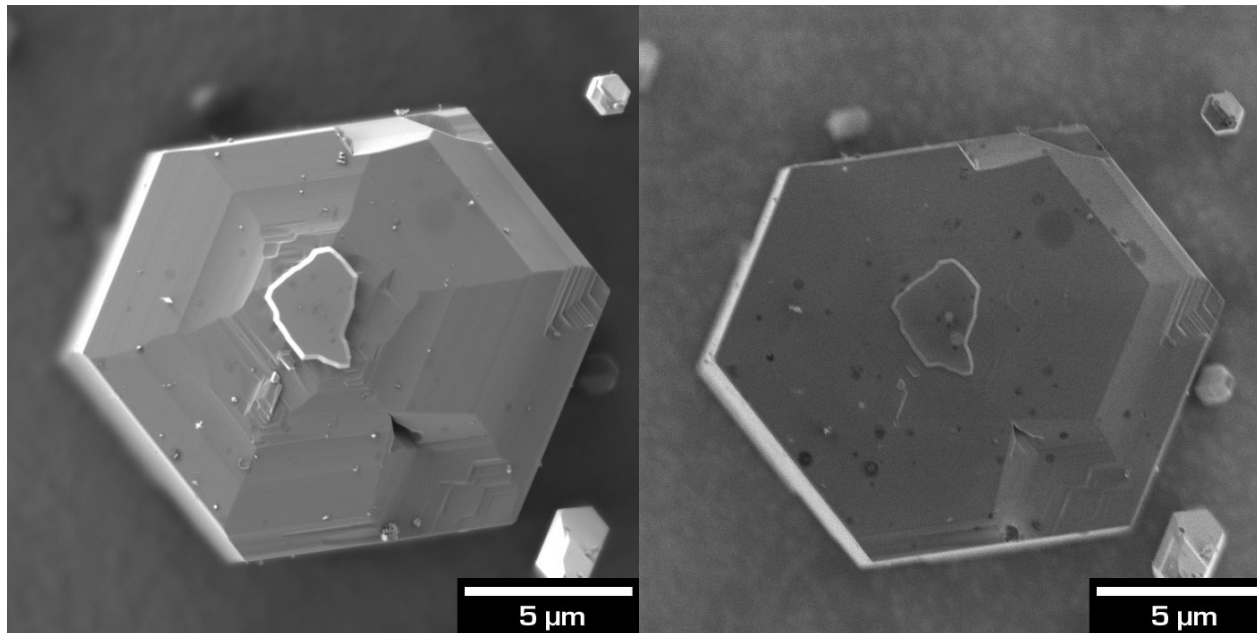

Which image is the secondary electron image?

Example 4: Dust on WC (different Z materials)

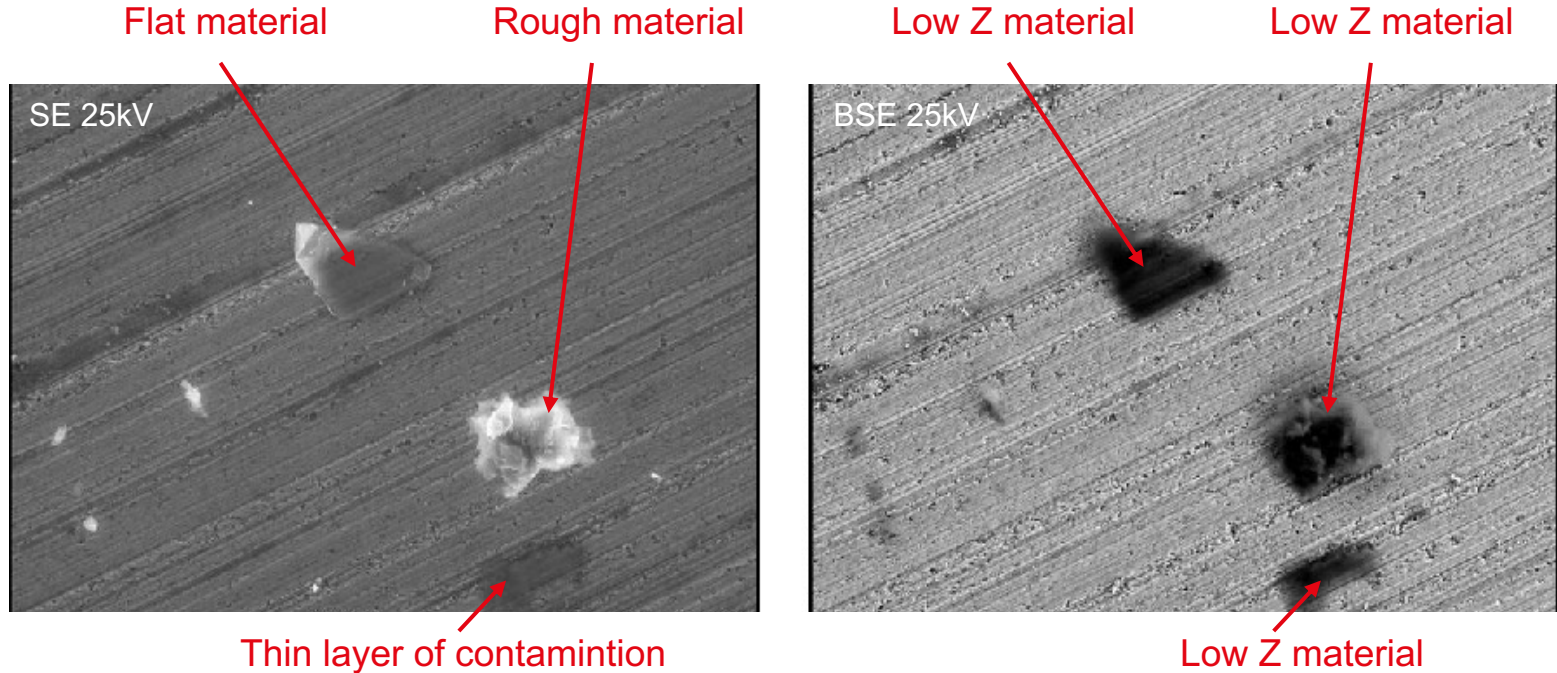

Why does the rough particle appear brighter in the SE image?

SEM signals | Effect of sample tilt on BSE yield

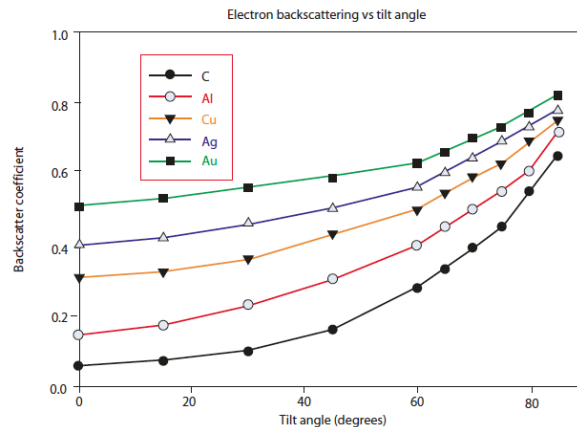
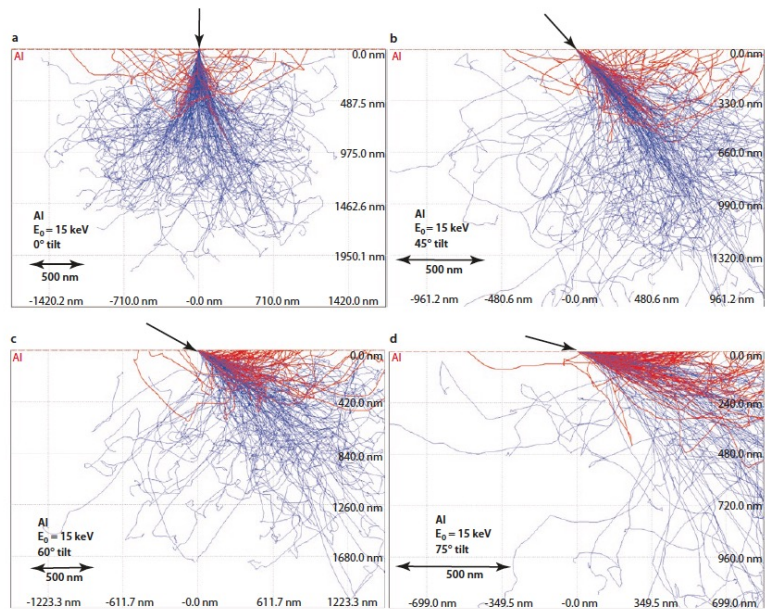

Note how large surface roughness (tilt) can affect the contrast

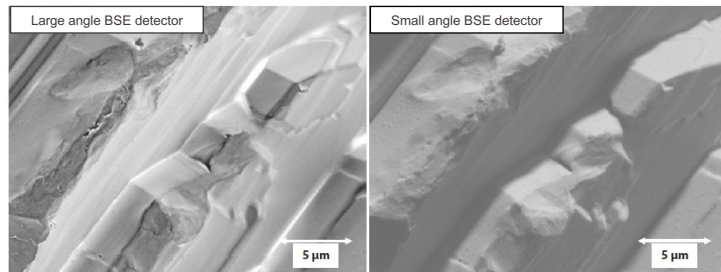

Pure silver with topographically irregular surface

When sample is tilted, the interaction volume is closer to the surface. Thus, more electrons can escape from the sample, giving more signals.

Be careful not to interpret surface roughness as Z-contrast

SEM signals | Effect of sample tilt on BSE yield

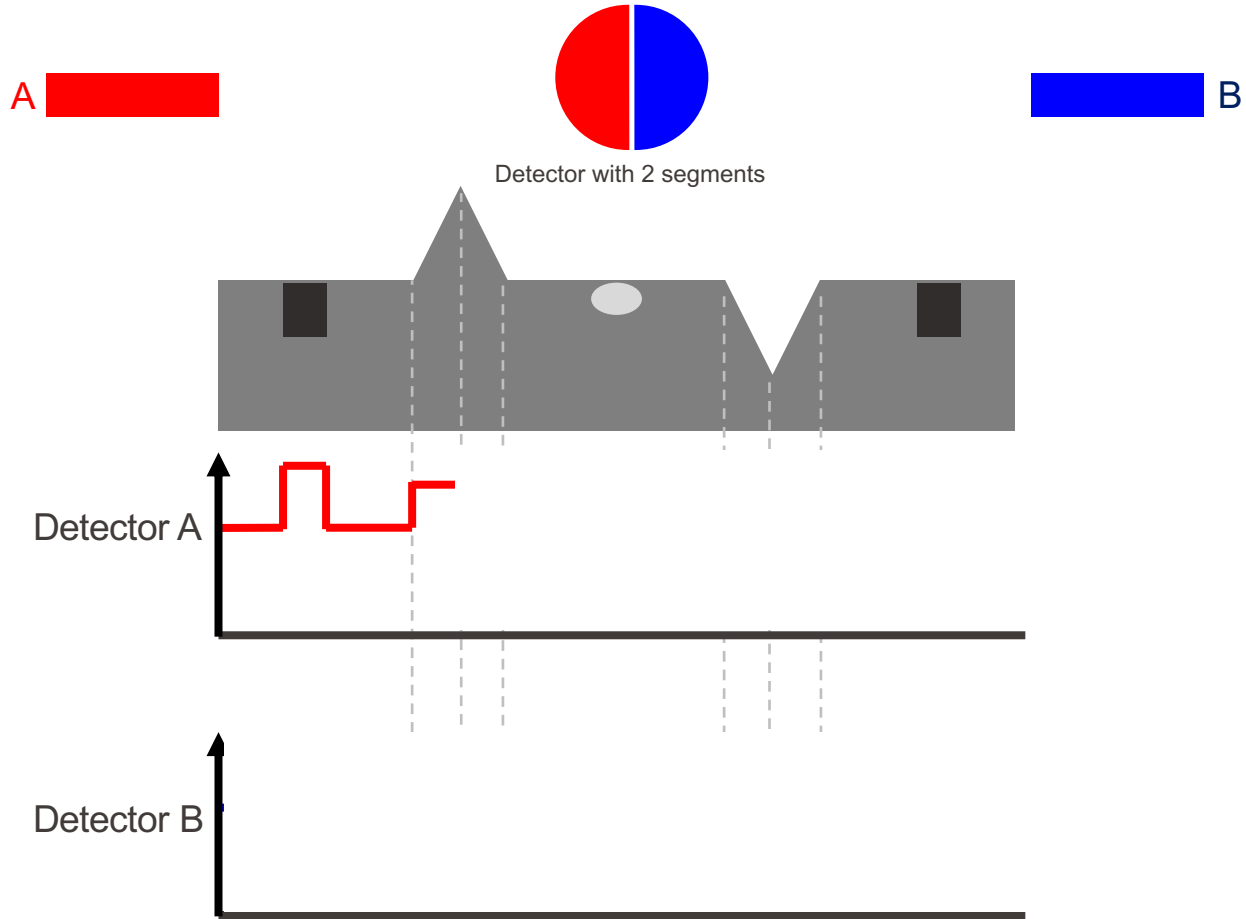

SEM signals | Effect of sample tilt on BSE yield

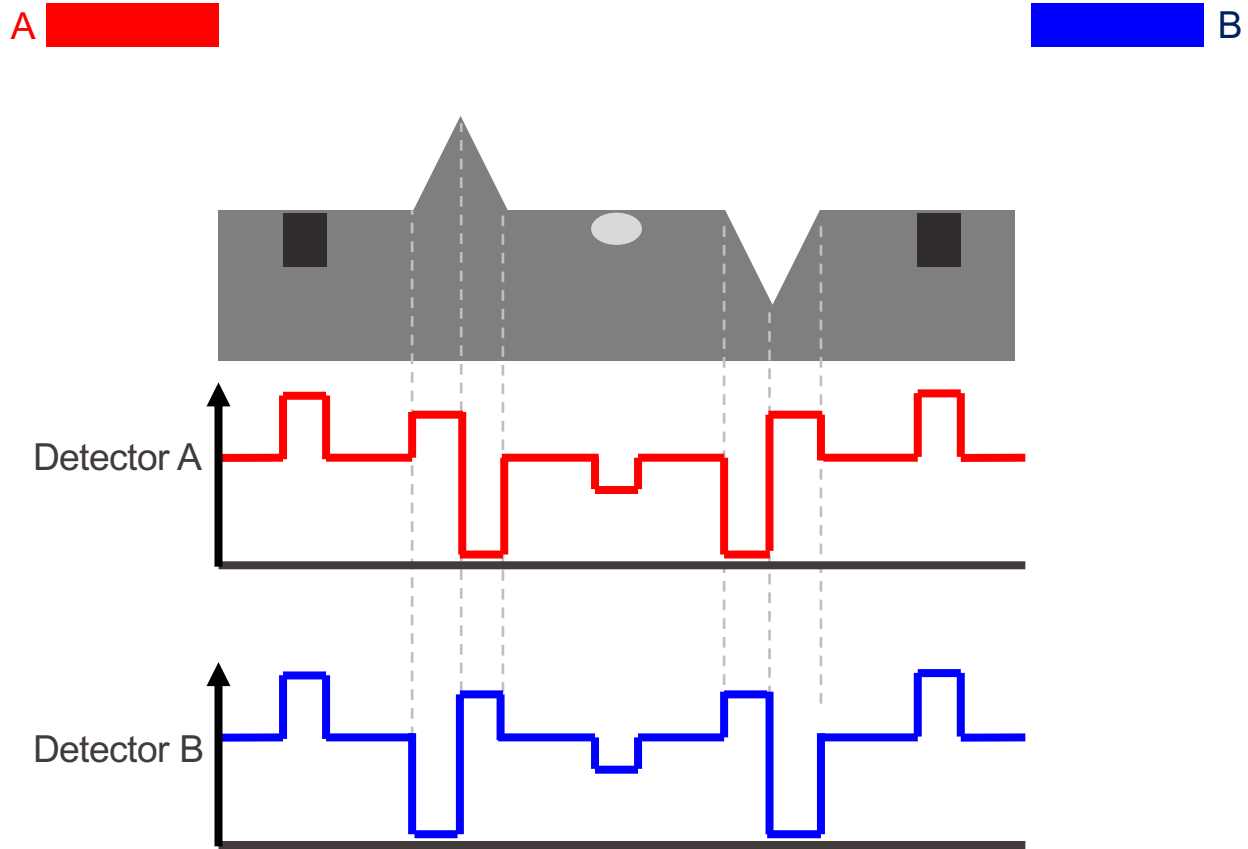

SEM signals | Effect of sample tilt on BSE yield

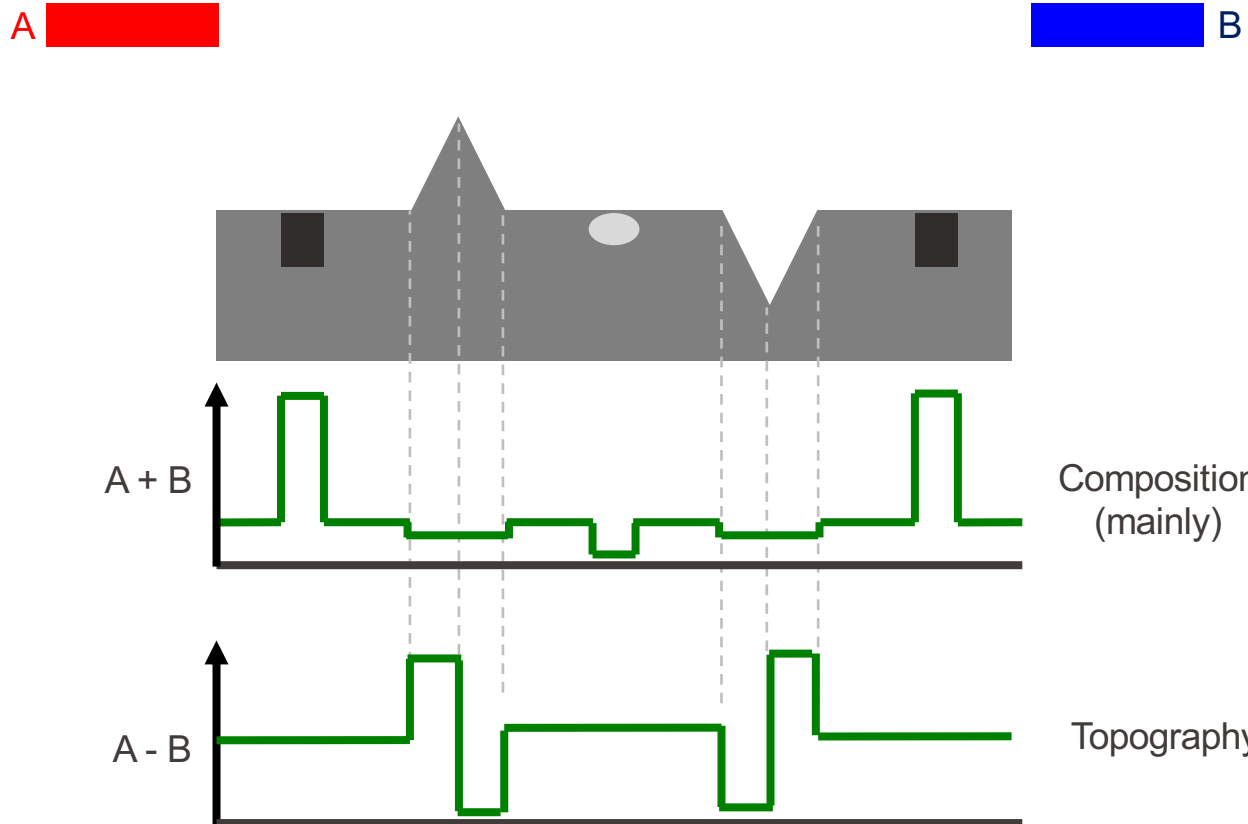

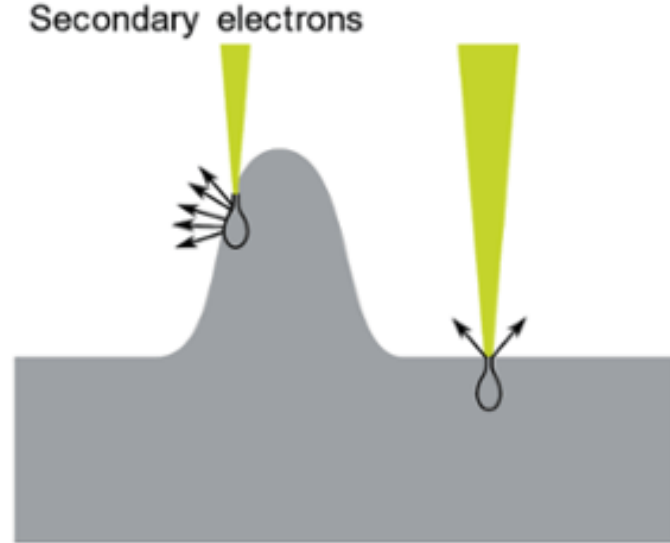

- If a sample is tilted, the interaction volume is tilted and is closer to the surface. Thus, more SE can escape from below the surface, giving higher signals received by the detector.
- The same principle is true for rough surfaces: Sloped surfaces and edges have an interaction volume that is effectively tilted and have higher SE yield.

Rough surfaces generates higher SE image signal.

Titling the specimen can change SE image contrast.

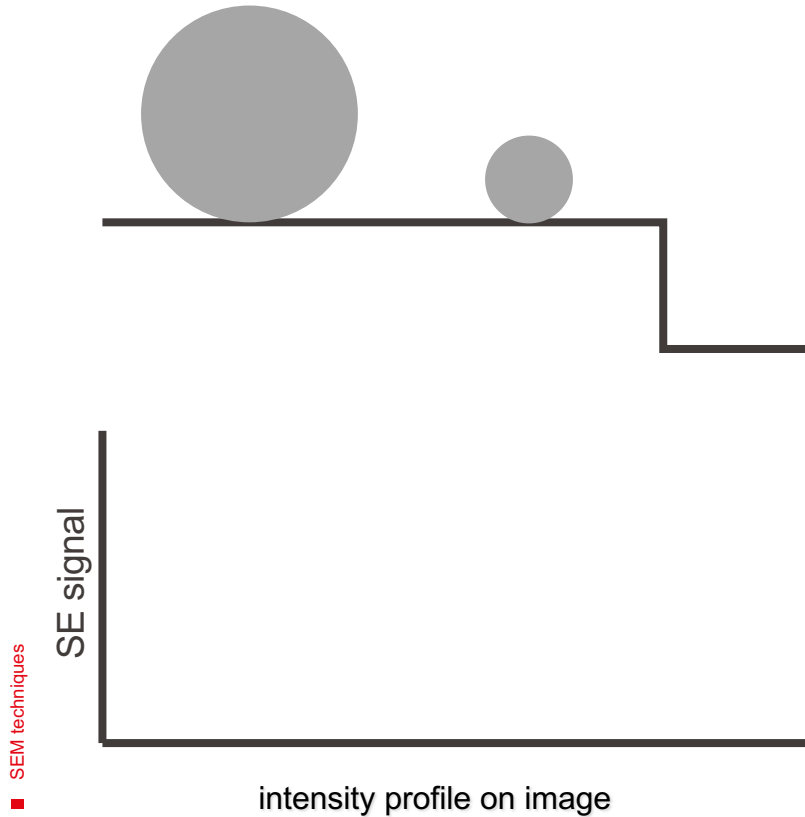

**Do not forget, in SEM:
The signal is displayed at the probe position,
not at the actual SE production position!!!**

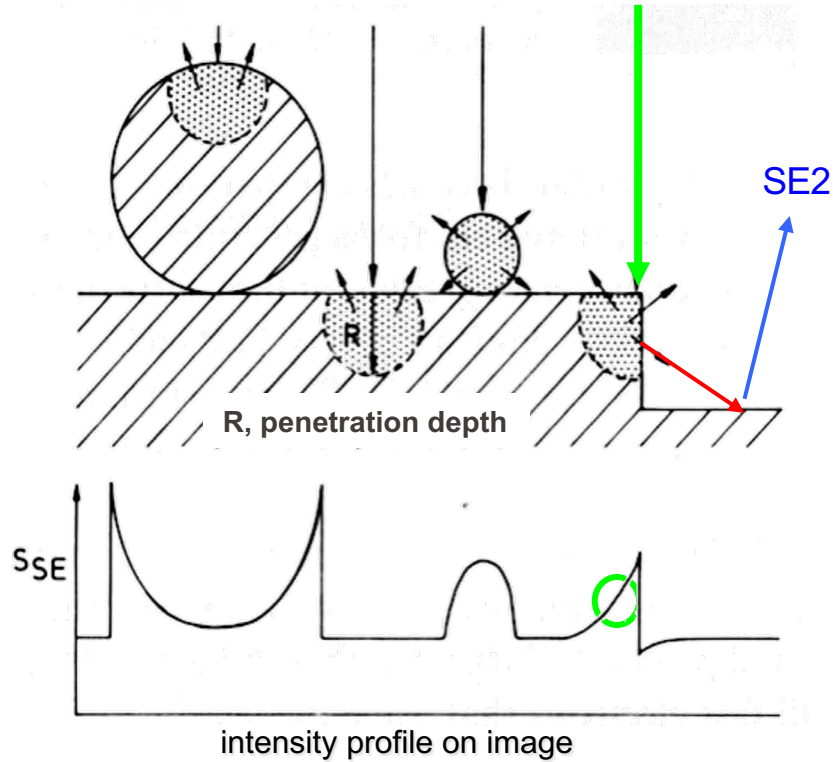

Edge effect!

Increase of the signal at an edge caused by SE2 and SE3 due to scattering of the BSE electron from the edge.

SEM signals | Edge effect & beam energy



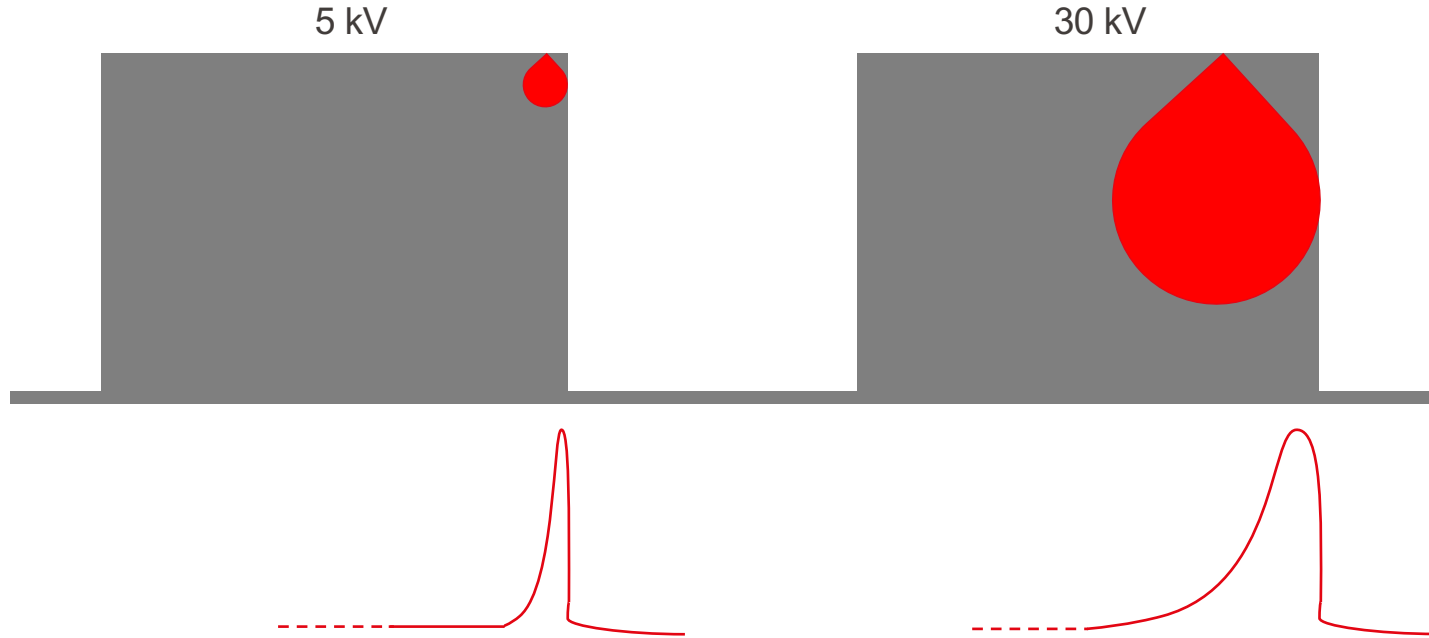

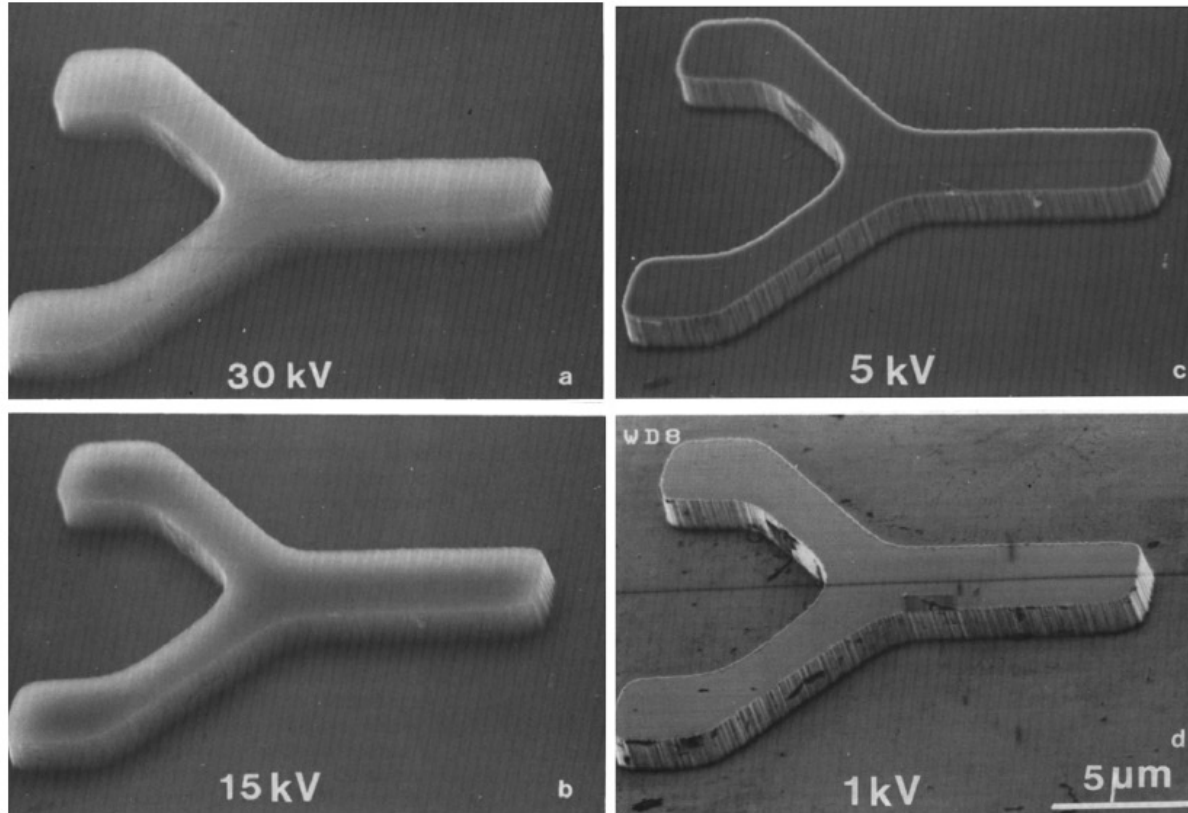

In which image the Edge effect is more pronounced

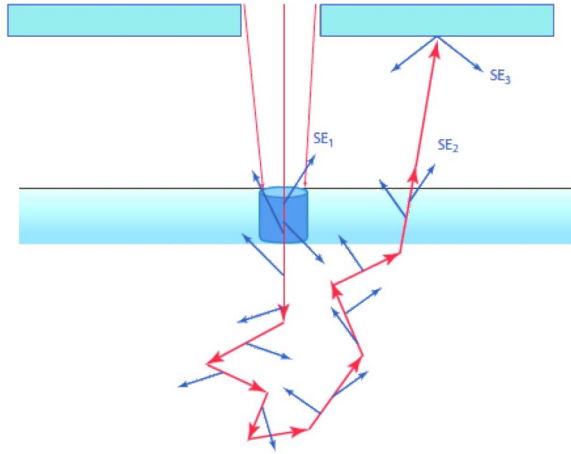

Red trajectories = Primary and backscattered electrons
 Blue trajectories = Secondary electrons (SE1, SE2, SE3)

- SE1:** From interactions of the incident probe with specimen atoms. SE1s are produced in close proximity to the incident beam and thus represent a high lateral resolution signal.
- SE2:** From interactions of the high energy BSEs with specimen atoms. Both lateral and depth distribution characteristics of BSEs are found in the SE(II) signal and thus it is a comparatively low resolution signal
- SE3:** Are produced by high energy BSEs which strike the pole pieces and other solid objects within the specimen chamber.

**NOTE: Image signal is displayed at the probe position
 NOT at the actual SE production position**

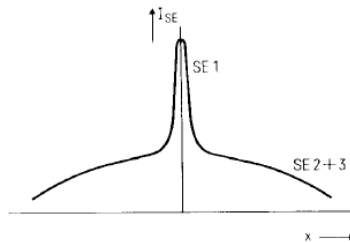

**SE1 high lateral resolution
 SE2 + SE3 reduce resolution**

SEM signals | Edge effect

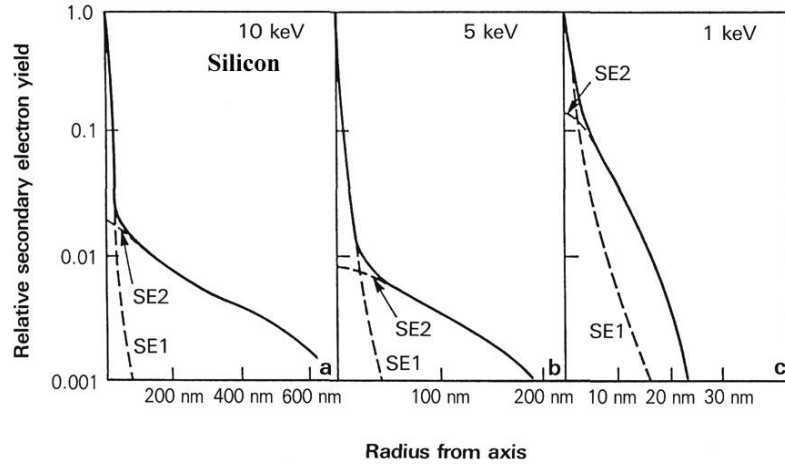

**NOTE: Image signal is displayed at the probe position
NOT at the actual SE production position**

**SE1 high lateral resolution
SE2 + SE3 reduce resolution**

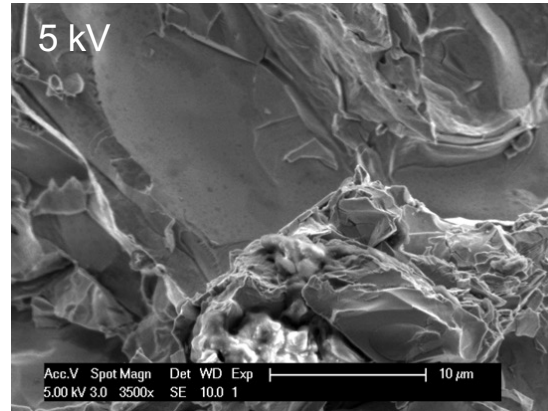
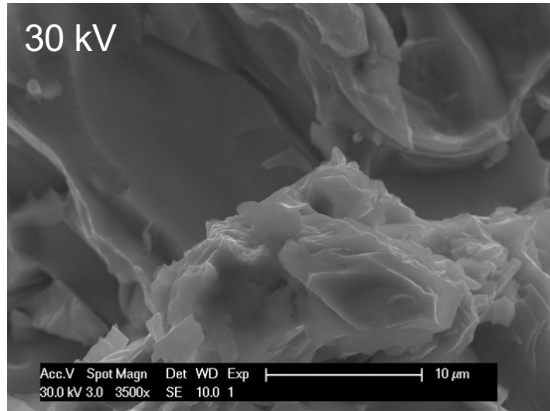

Which image has a better spatial resolution?

Detector position

180° rotation

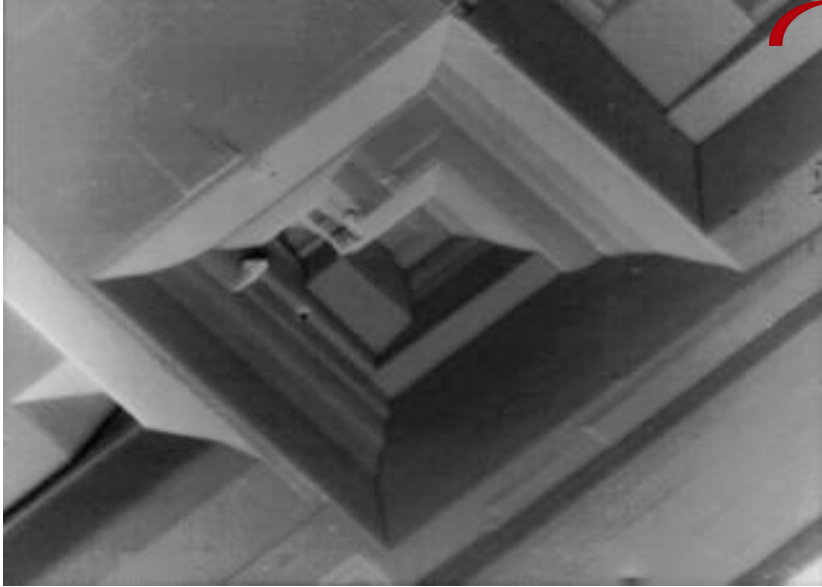

Pyramid



Left image rotated by 180° → Etched pit!!!

Since we are used to having illumination from the overhead, we instinctively expect that brightly illuminated features must be facing upward to receive light from the source above, while poorly illuminated features are facing away from the light source.

Interpretation requires to know where the detector is located.

Detector position | Light-optical analogy

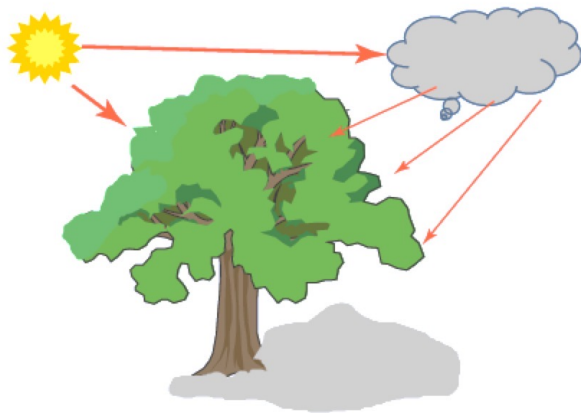

We have evolved in a world of top lighting (sun or ceiling light). Features facing the Sun are brightly illuminated, while features facing away are shaded but receive some illumination from atmospheric scattering.

Bright = facing upwards

To establish the strongest possible light-optical analogy for the SEM-ETD image, we need to create a situation of apparent top lighting.

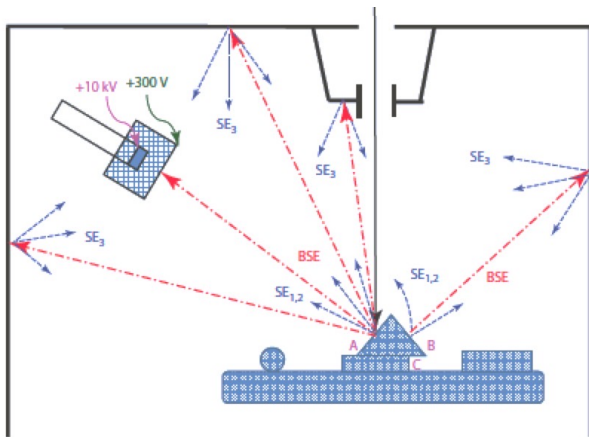

Thus, if we imagine the specimen scene to be illuminated by a primary light source, then that light source occupies the position of the ETD and the viewer of that scene is looking along the electron beam. The SE₃ component of the signal provides a general diffuse secondary source of illumination that appears to come from all directions.

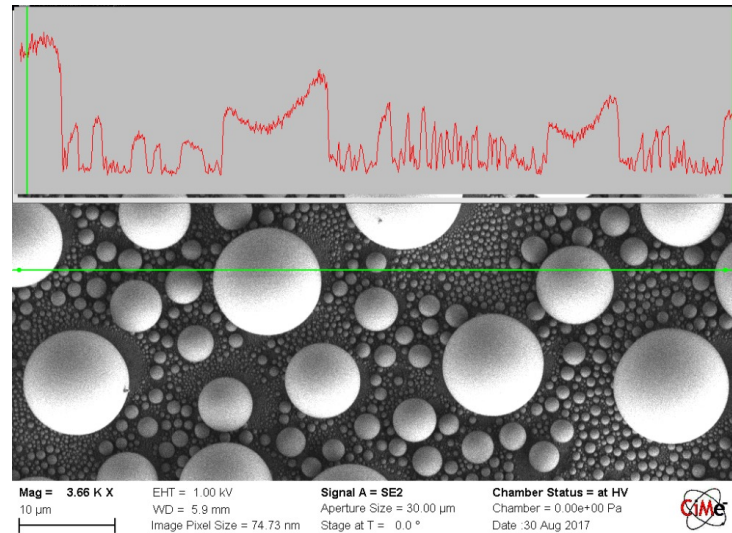
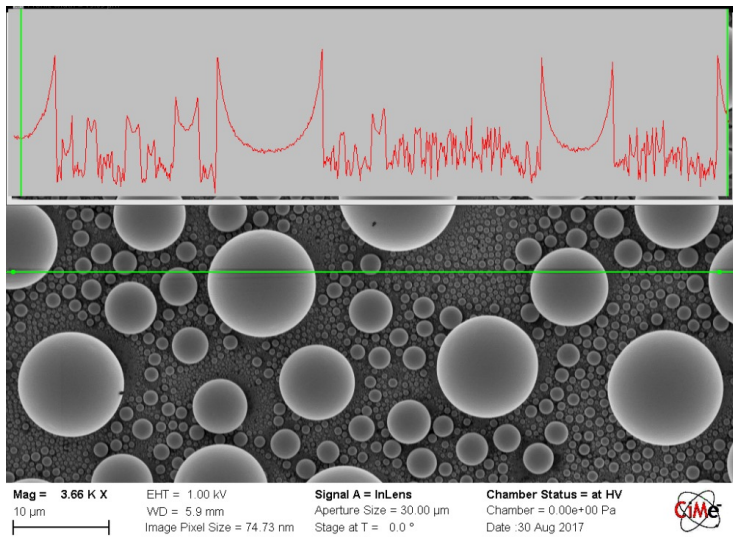

Why they are different?

Which image is taken with an Everhart-Thornley Detector (ETD)
 What is the position of the detector with respect to the image?

In-lens SE detector

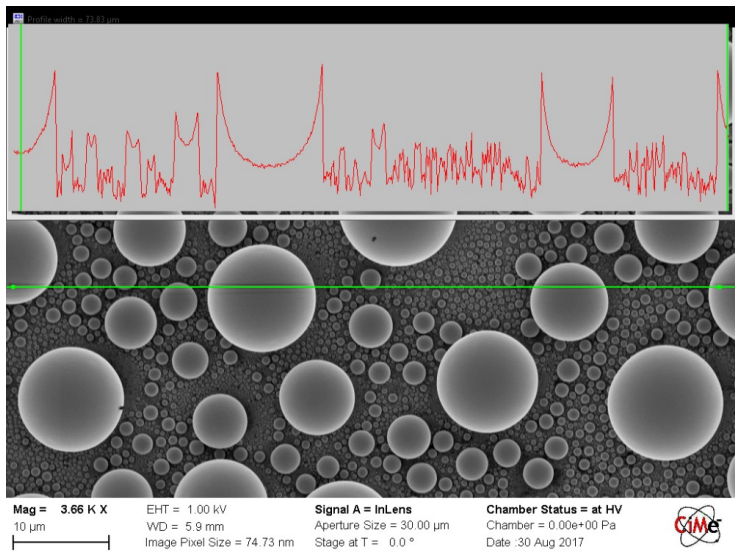

Everhart-Thornley detector

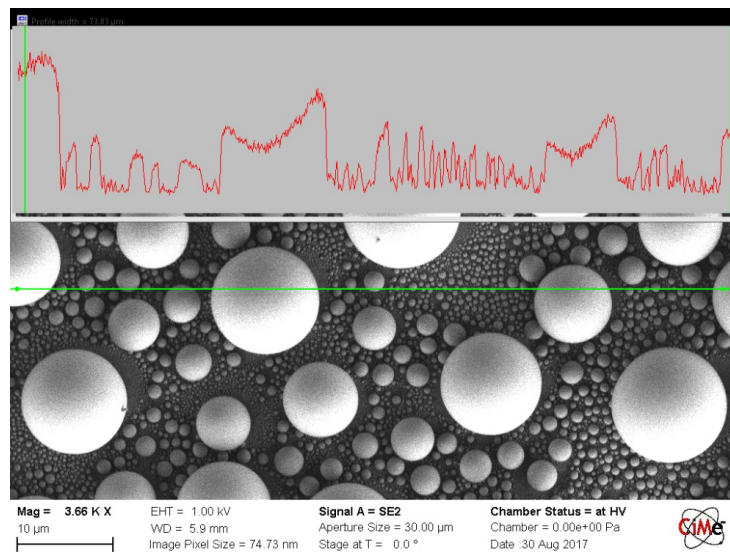

Parameters affecting Resolution (and Visibility)

- **Fundamental**
 - Electron wavelength (beam energy) and diffraction limit: → Rayleigh criterion
 - Aberrations: enlarges the probe size
 - Probe size (or spot size) means the diameter of the final beam at the surface of the specimen
- **Operational**
 - Pixel size = scan step size
 - Probe size (also defines probe current and affects visibility)
 - Visibility:
 - Scan speed (i.e. dwell time) and “signal to noise ratio”
 - Contrast
- **Sample**
 - Type and depth of emitted electrons signal
 - System/Specimen stability → Challenges (charging, contamination, beam damage)

Beam induced changes to the sample:

- Atom displacement ("knock on")
 - Radiation damage,
More severe for high beam energies

- Chemical bond breaking
 - Radiolysis
Increasing beam energy can lessen radiolysis

- Lattice atom vibrations (phonons)
 - Sample heating

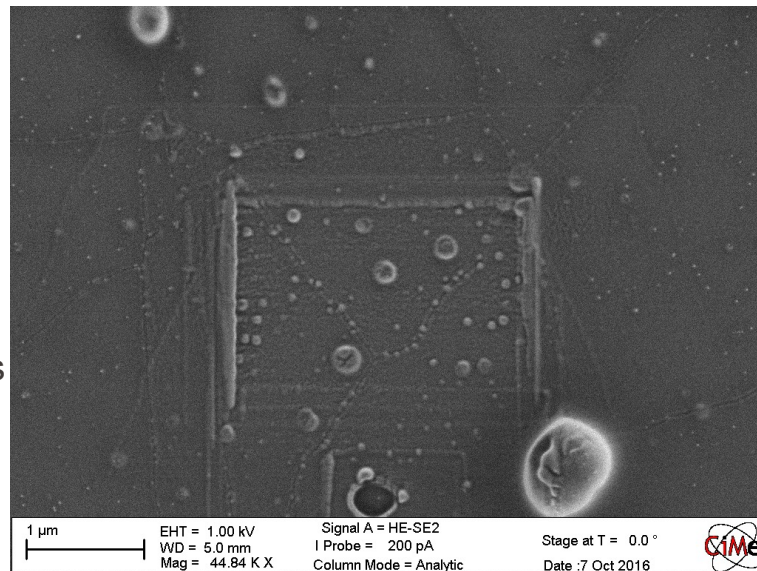

Hydrocarbon build-up on surface

- Masks surface features and information about the sample
- Sources:
 - Sample surface
 - SEM chamber
 - Beam induced degradation and migration of sample compounds
- To avoid / minimize:
 - Use gloves when handling samples
 - Plasma cleaning sample prior to observation

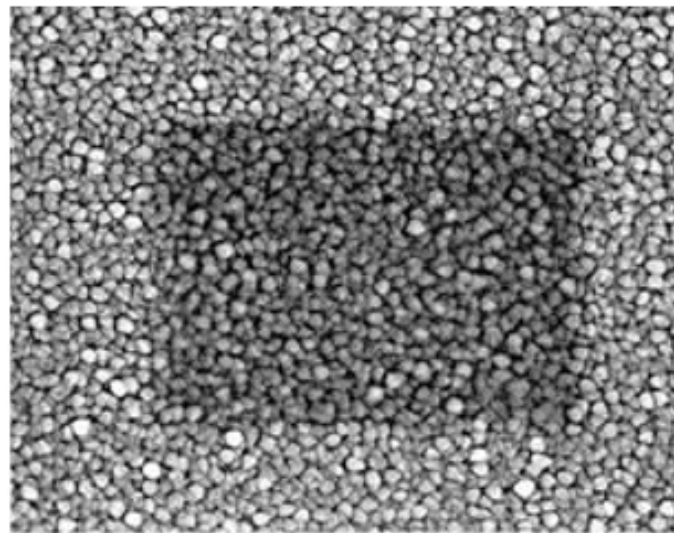

Accumulation of negative charge

Occurs in insulating samples (also in samples that are not well grounded)

- Charging deflects the low-energy secondary electrons (mainly, but can affect BSE) causing image distortions and contrast changes
- Depends on:
 - Material properties (surface resistivity)
 - Beam energy and current)
 - Scan rate
- Ways to mitigate charging
 - Coat the sample with a conductive layer
 - Work at low kV
 - Use low currents (noisy images)
 - Use low-vacuum mode
 - Charge compensation devices
 - **Use the “magic” charge neutrality voltage**

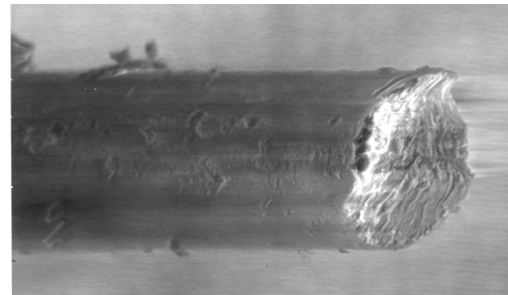

Fiberglass*

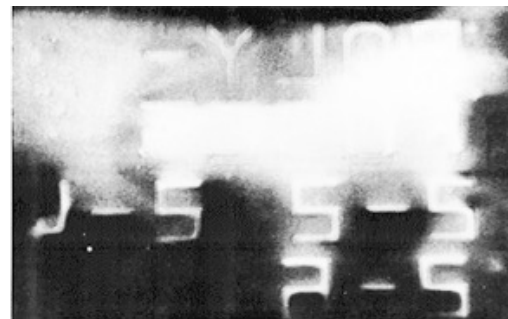

SiO₂ substrate

Example: Dust particles on a metallic substrate

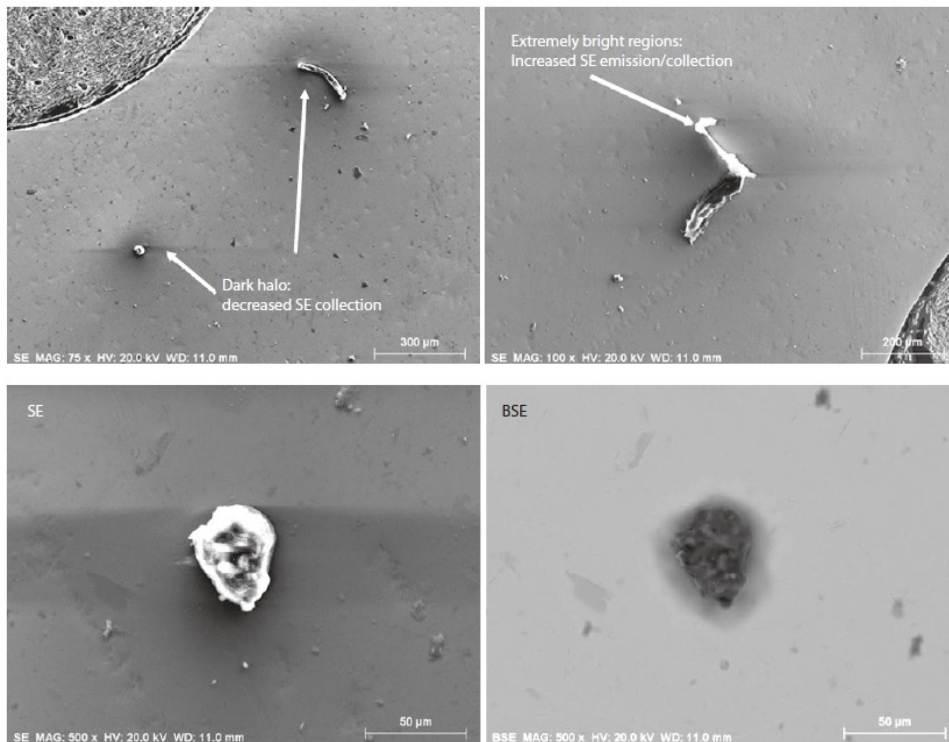

The “magic” charge neutrality voltage

Charge injected by the beam is balanced by the charge leaving as BSEs and SEs

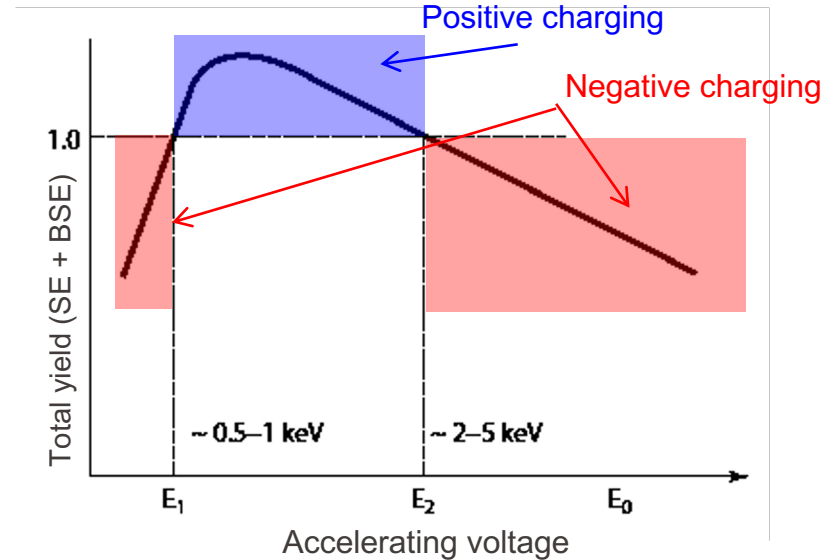

The “magic” charge neutrality voltage

E1 and E2 values depend on the material (approximately 0.5-2 kV)

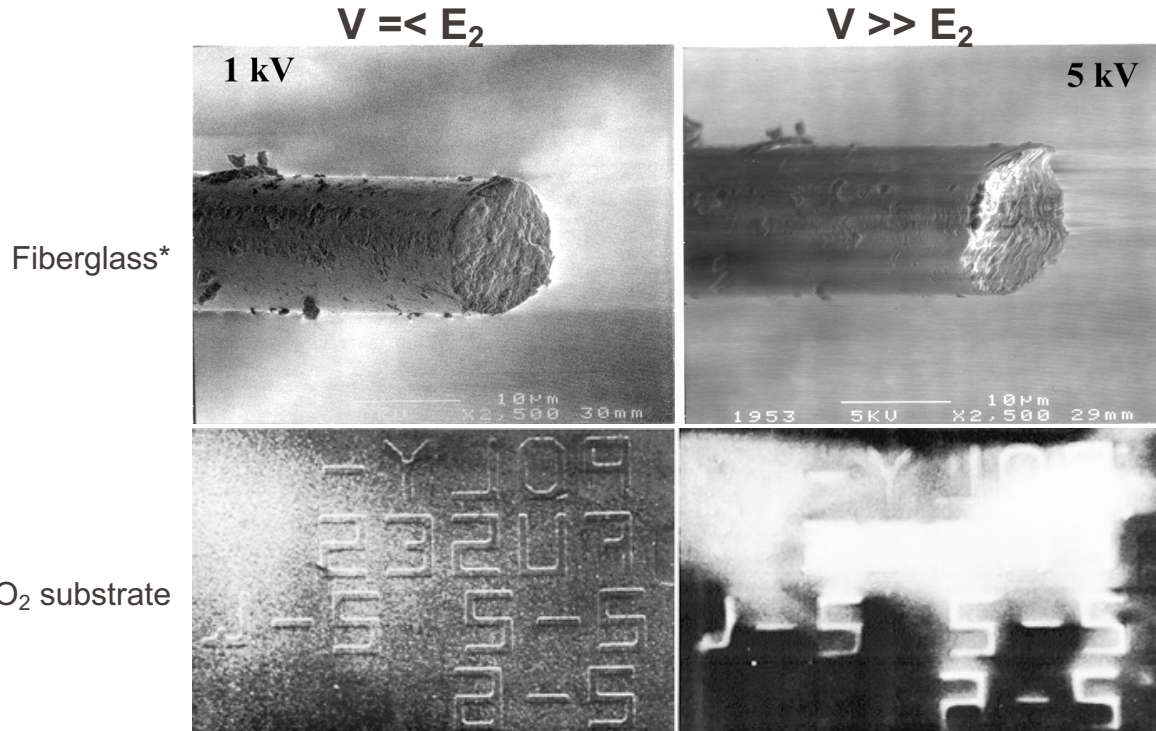

Example of changing scan speed

Uncoated quartz fragment – 1kV ETD with positive bias

Fast scan

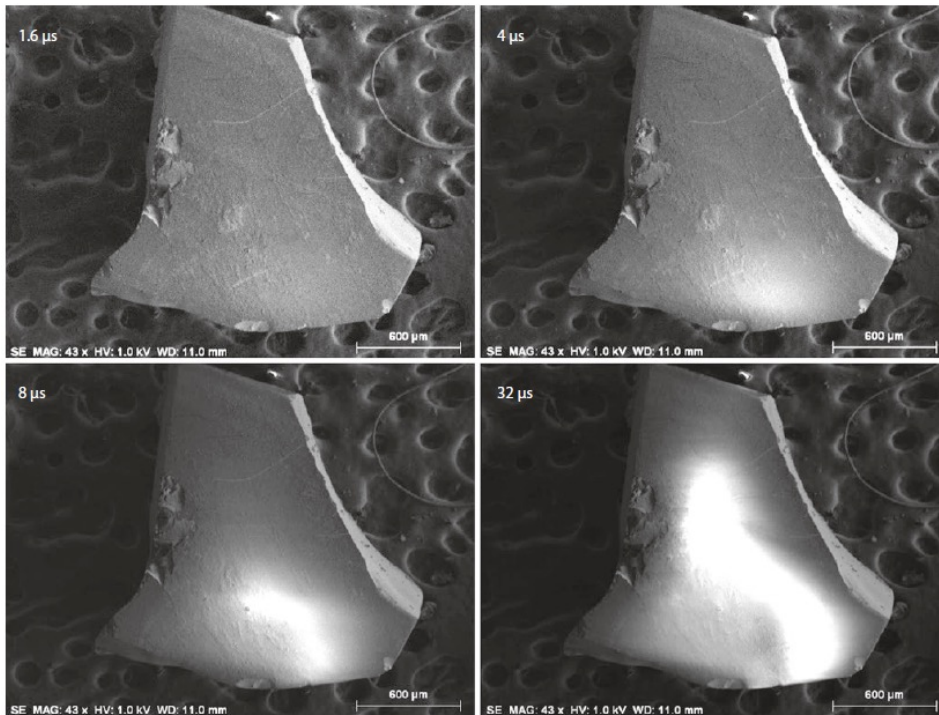

Slow scan

Example of combining neutrality voltage and fast scan

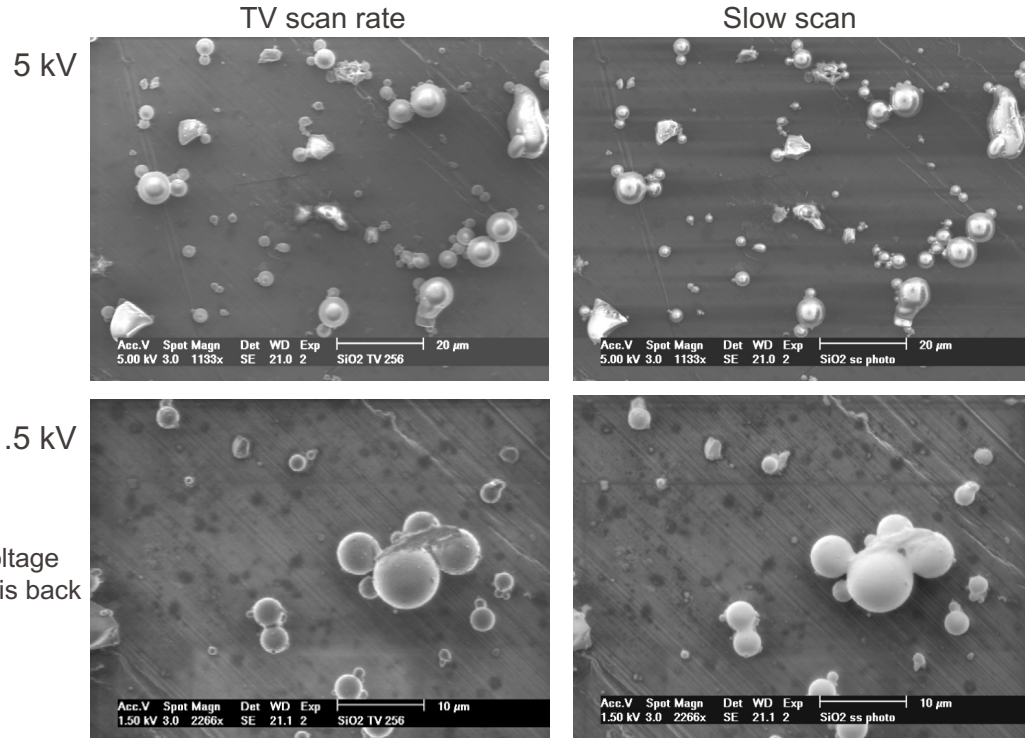

SiO₂ spherical particles

Example of using low-vacuum mode

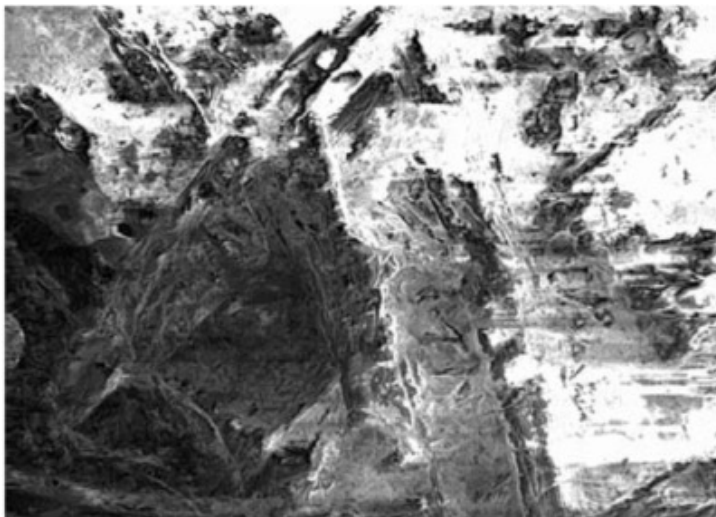

Paper under vacuum

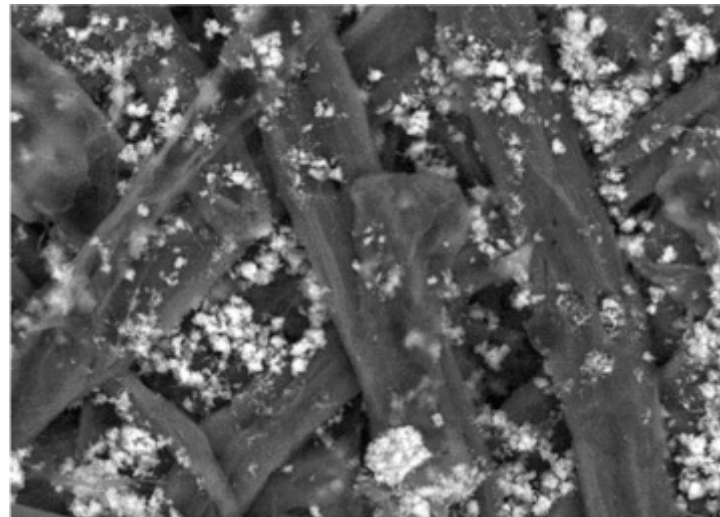

Paper in low-vacuum (40 Pa)

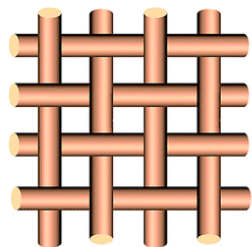

Cu gauze

Wet chemical oxidation

2.5 M KOH
0.125 M $(\text{NH}_4)_2\text{S}_2\text{O}_8$
10 min

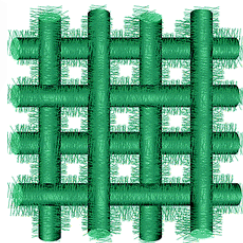

Spray coating
PTFE + carbon black

Heating
350 °C in air for 1h

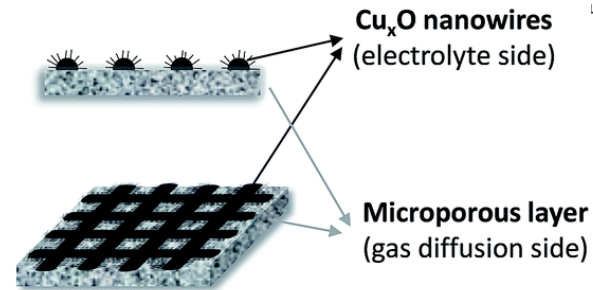

Gas diffusion electrode

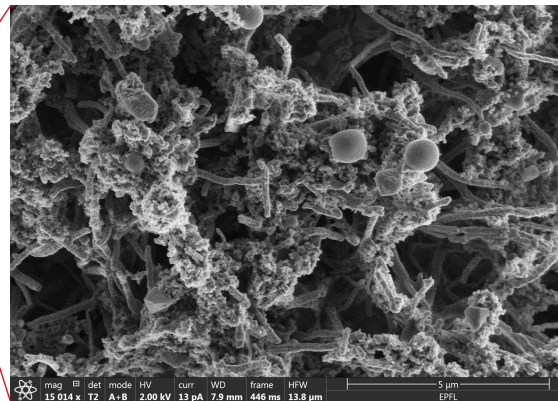
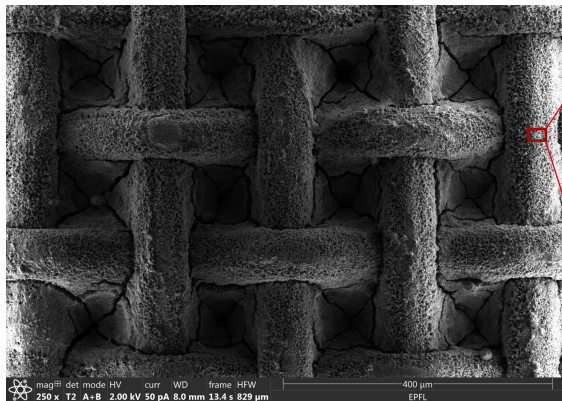

Compare and interpret the contrast you see in the BSE/SE images

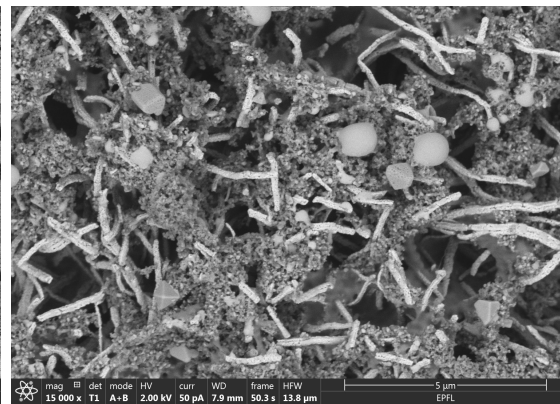
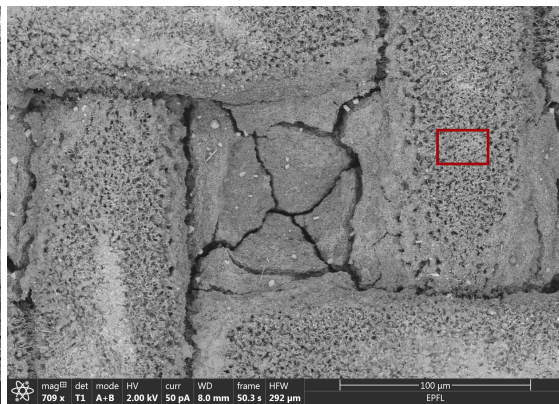
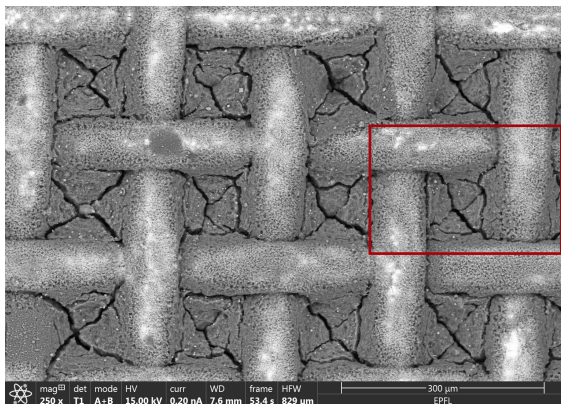
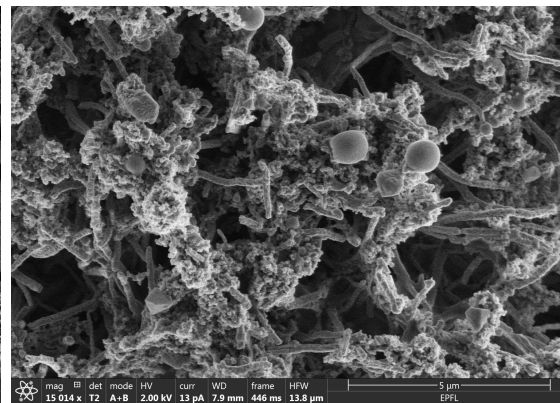
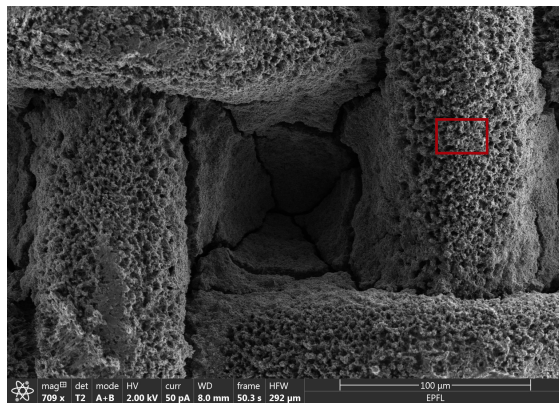
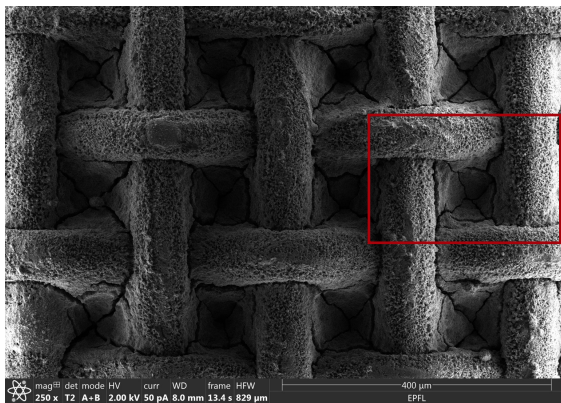

Discuss the changes visible in these BSE images acquired at different beam energies?

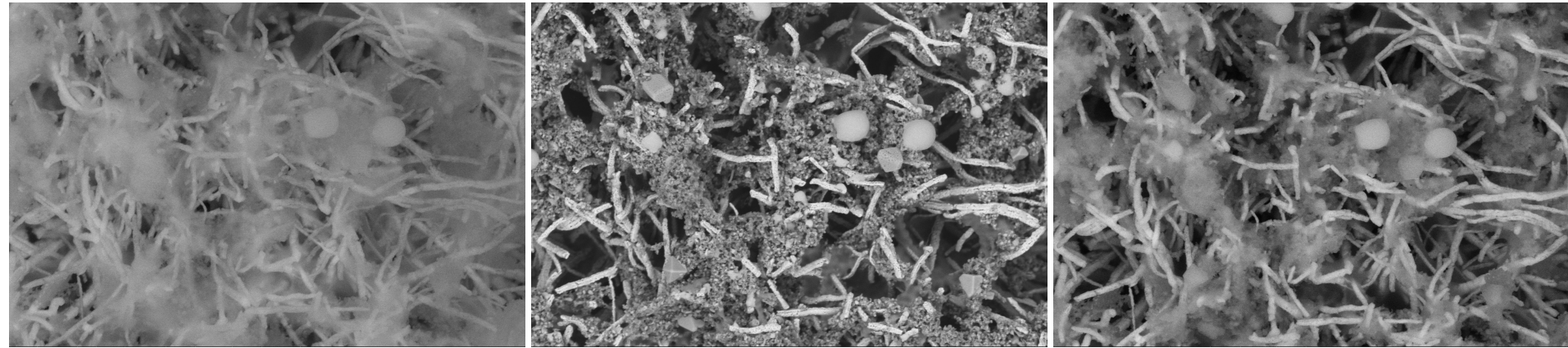

Discuss the changes visible in these SE images acquired at different beam energies??

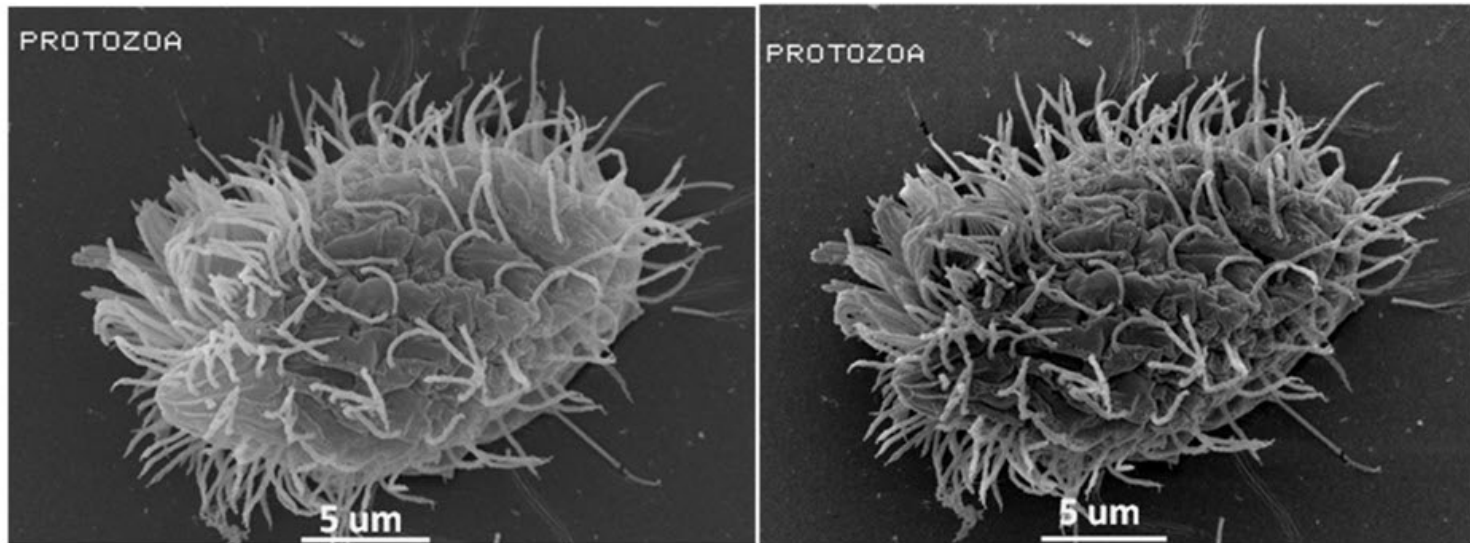

In which image the “edge effect” is more pronounced?
Which one is taken with a higher beam energy?

SE and BSE micrographs of a steel ball

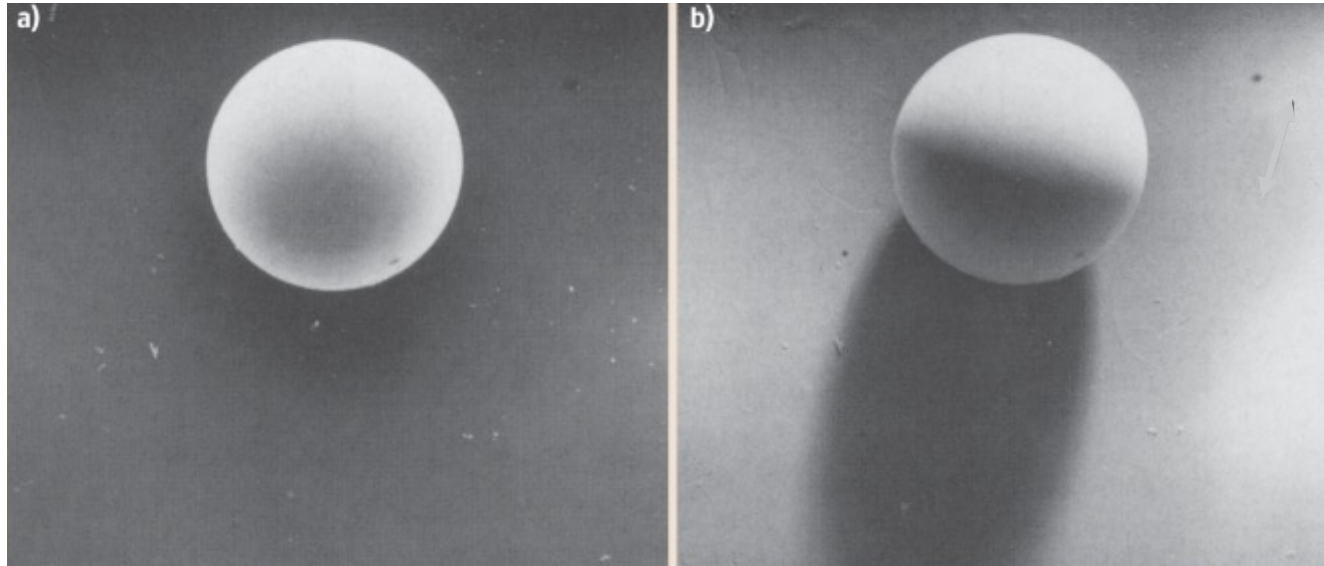

Which image is a secondary electron (Everhart-Thornley Detector) image?
Where is the detector in the SE image?

Discuss the artefacts visible in some of the images.

How it has been resolved?

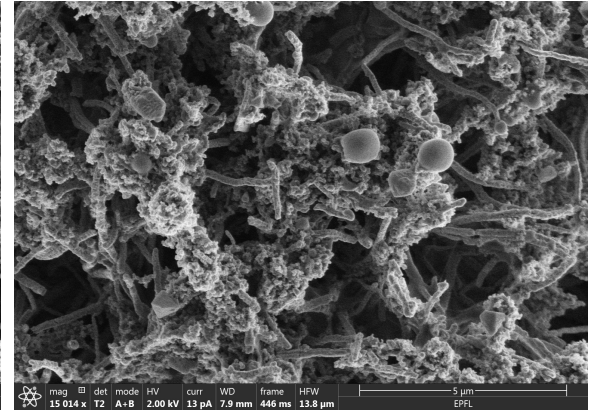
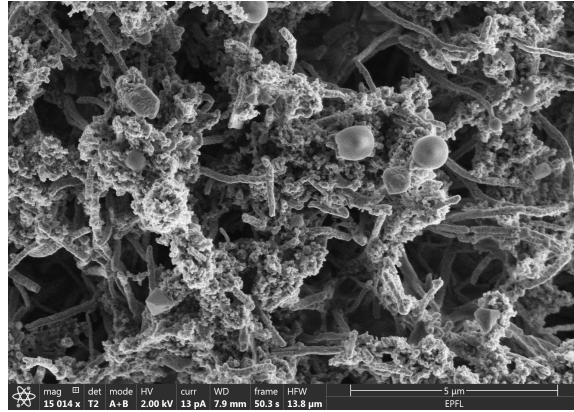
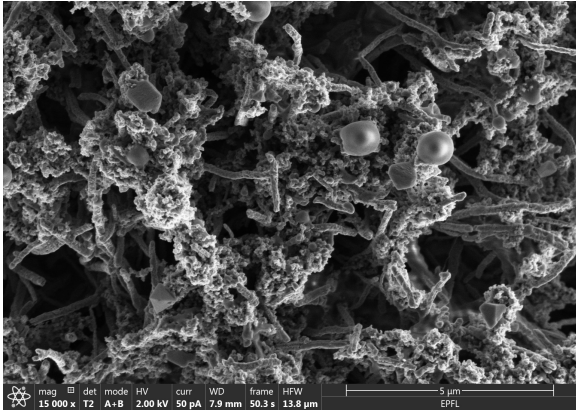

- Scanning Electron Microscopy and X-Ray Microanalysis
Springer, by Joseph Goldstein et al.

Hardcopy at EPFL & CIME libraries

- Image formation in low-voltage scanning electron microscopy
Springer, by L. Reimer

Available online

- Physics of image formation and microanalysis
Springer, by L. Reimer

- Scanning electron microscopy in Handbook of Microscopy
Springer, by C.W. Hawkes and J.C.H. Spence (eds)

- Science of Microscopy by C.W. Hawkes and J.C.H. Spence (eds) (Springer)

Hard copy available at CIME and EPFL libraries

