

Electrochemistry for Materials Technology

ENERGY APPLICATIONS

MER Dr Jan Van herle

EPFL-Valais GEM (Group of Energy Materials)

Tel. 58263/ jan.vanherle@epfl.ch/ gem.epfl.ch

Electrochemistry – Energy Applications

Converting fuels *continuously* to electricity & useful heat:

• FUEL CELLS



Converting fuels to electricity and vice-versa (*size-limited*):

• BATTERIES

e.g. storage



Converting electricity to fuels and chemicals

• ELECTROLYSIS

e.g. H₂ production



e.g. Al production

FUEL CELLS – General aspects

Principles, types, applications, strengths, efficiency

A Fuel Cell in a nutshell:

- works like a **battery**, fed with **gas**
- fuel is **directly** converted into electricity and useful heat
- typical sizes:
 - 1-20 W_e / H_2 , MeOH / portable electronics
 - 1 kW_e / natural gas / a house
 - 20 kW_e / H_2 / an electric car
 - 1 MW_e / biogas / CHP
- status: pilot & demonstration, R&D, pre-commercial

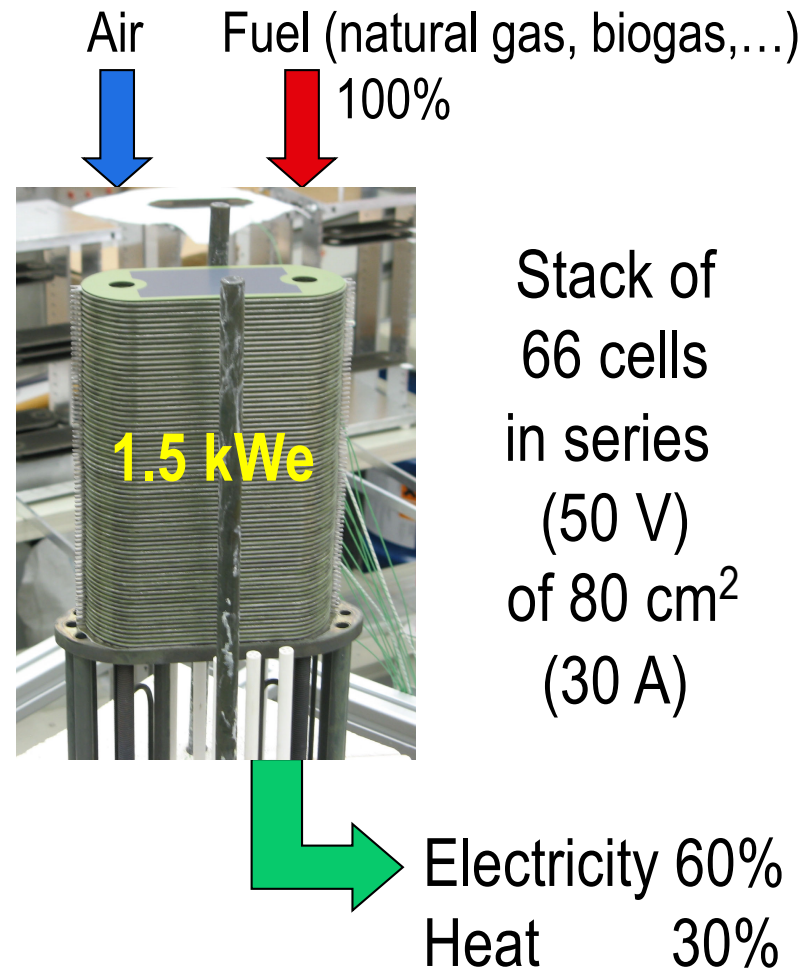

Highly pluridisciplinary topic

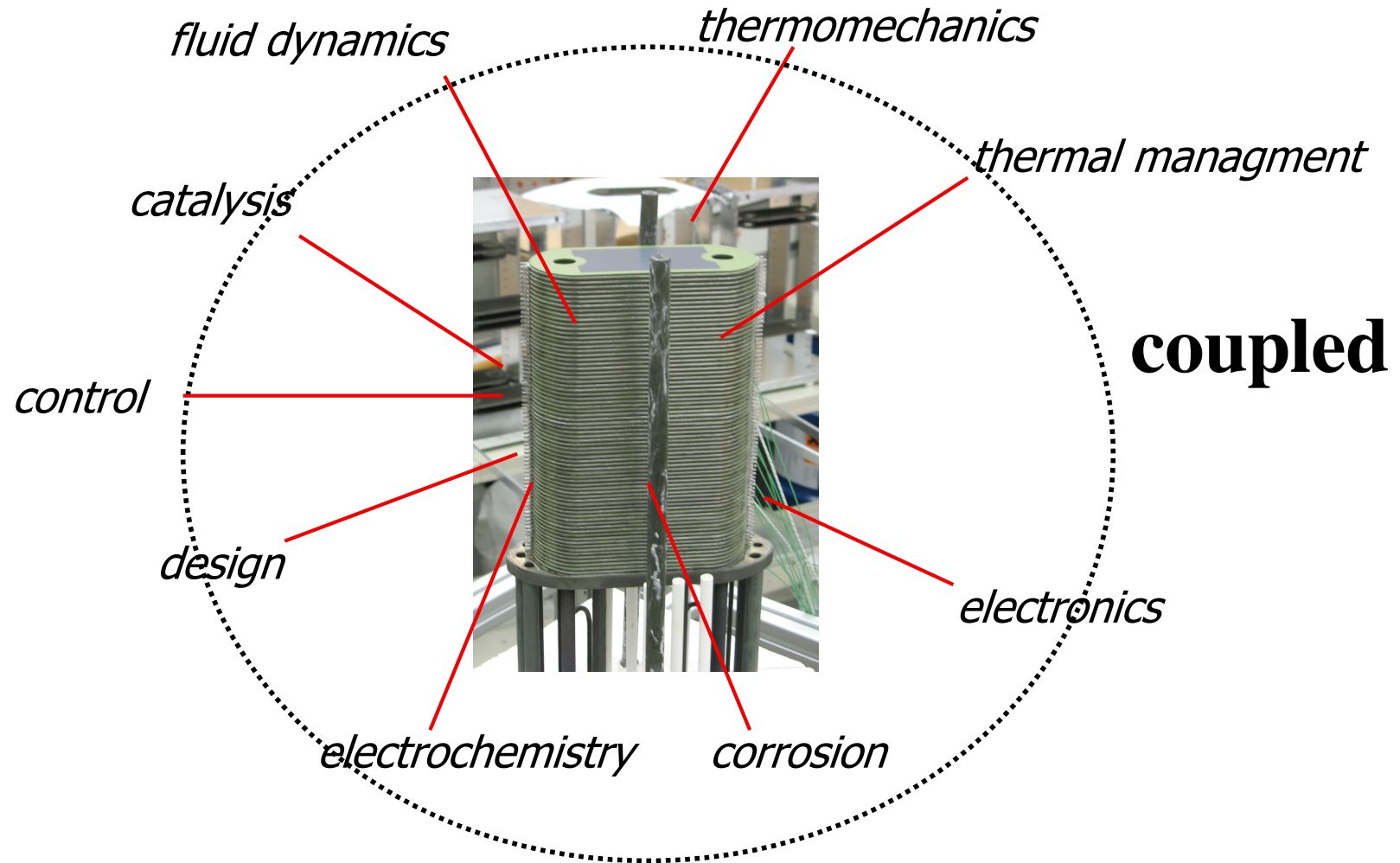

*At the crossroads of mechanics, chemistry, **materials science** and electrical engineering*

Learning objectives on “Fuel Cells”

- understand the underlying **principles** in order to assimilate more specialised literature
- distinguish the different fuel cell types and know their specific **applications** and power sizes
- differentiate fuel cells from other conversion technologies (batteries, engines, microturbines,...), know and argue their strengths and limitations
- explain why electrical **efficiency** is high, including and especially for **small scale** conversion (kW-MW-scale)

Components of a fuel cell (=a '*gas battery*')

- 2 solid electrodes (+,-) of **electronic** conduction
- **ionic** conductor (*solid* or *liquid*), electronically insulating, that separates the 2 electrodes
- at both interfaces between **electronic** and **ionic** conductors, there is
 - charge transfer (electrons)
 - mass transfer (molecules)to complete the circuit and sustain current flow (& mass flow), so as to deliver electricity

Operating principle

- we first describe the operating principle of a classical **battery** (lead - sulfuric acid)
- and then explain the similarities and differences with a **fuel cell** ('gas battery')
- we consequently introduce different fuel cell **types**, one by one (5 in total), depending on the **materials** used
 - the fuel cell type (name) is designated by its **electrolyte** material,
 - which can be solid or liquid,
 - and conduct charge depending on the **operating temperature (RT to 1000C!)**

Lead acid battery

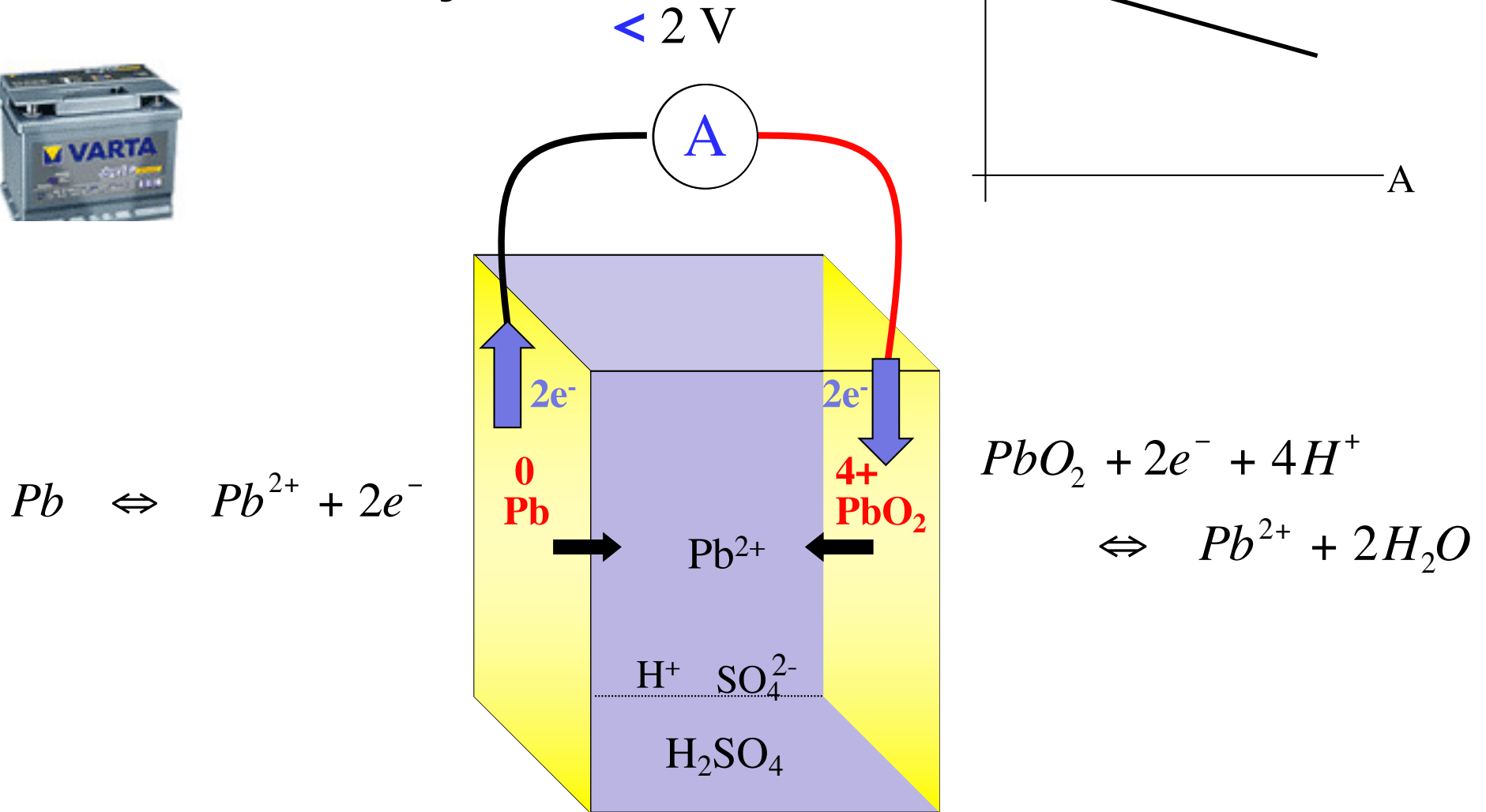
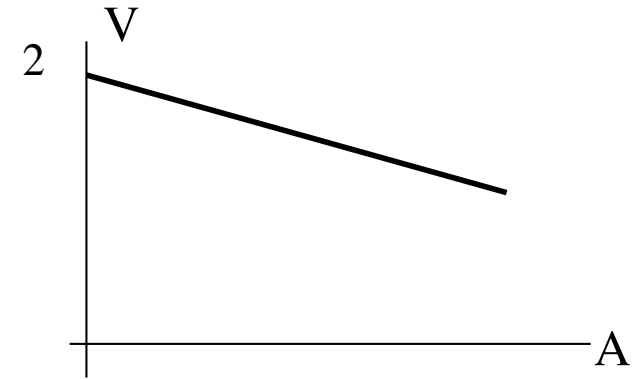

Electrode consumption (« active masses »)

1. Phosphoric acid fuel cell (PAFC)

< 1 V

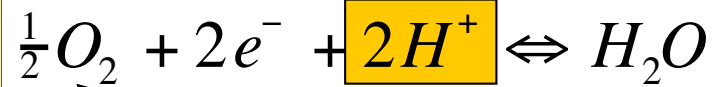
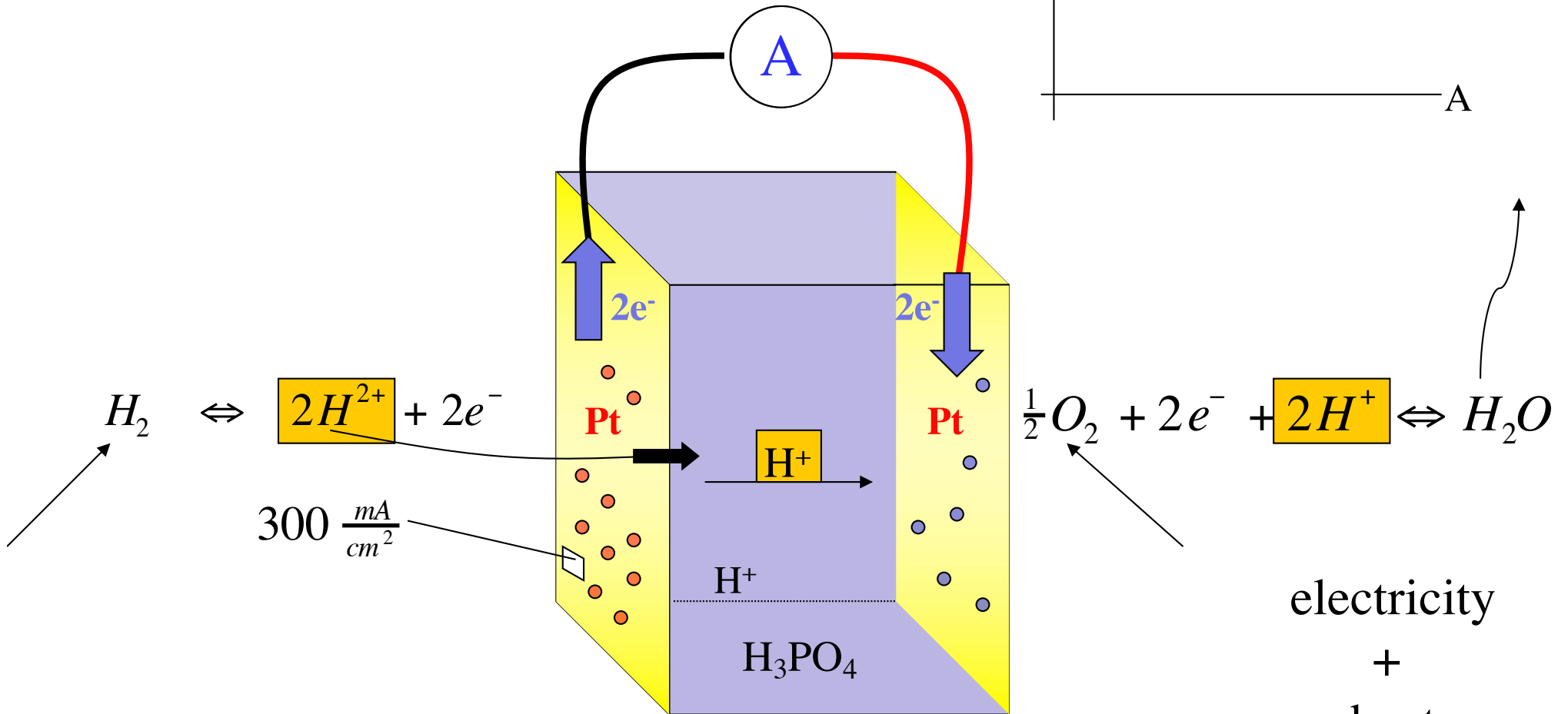
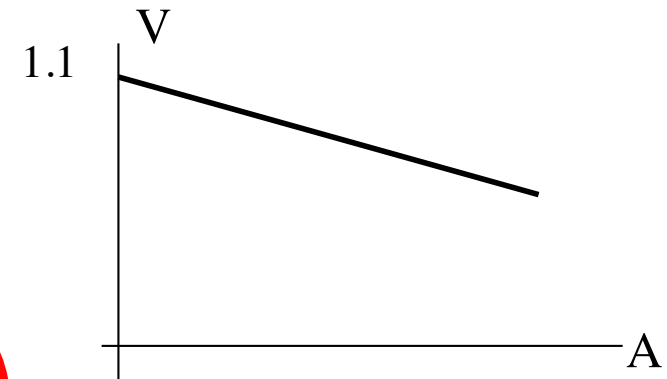

electricity
+
heat
200C

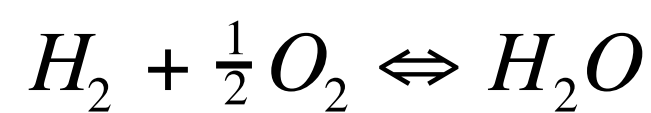

- consumption of gases
- electrodes are invariant (catalysts)

Gas diffusion electrodes

- allow to inject (extract) a gas into (from) a liquid
- reaction zone = “triple phase boundary” (gas/liquid/solid)

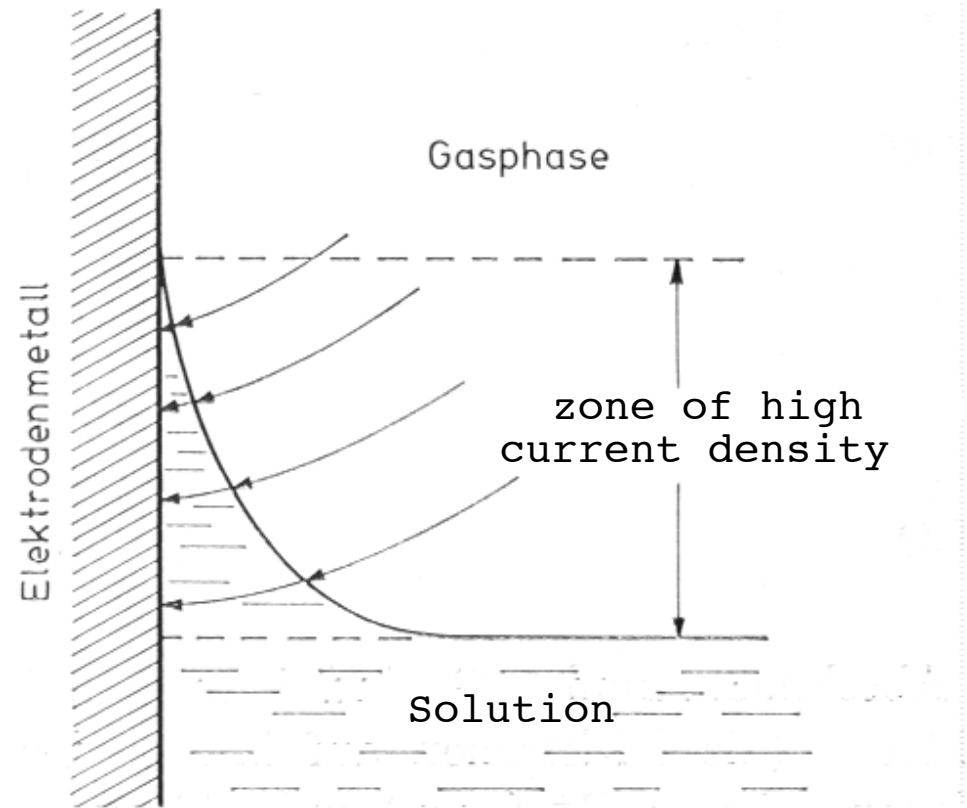
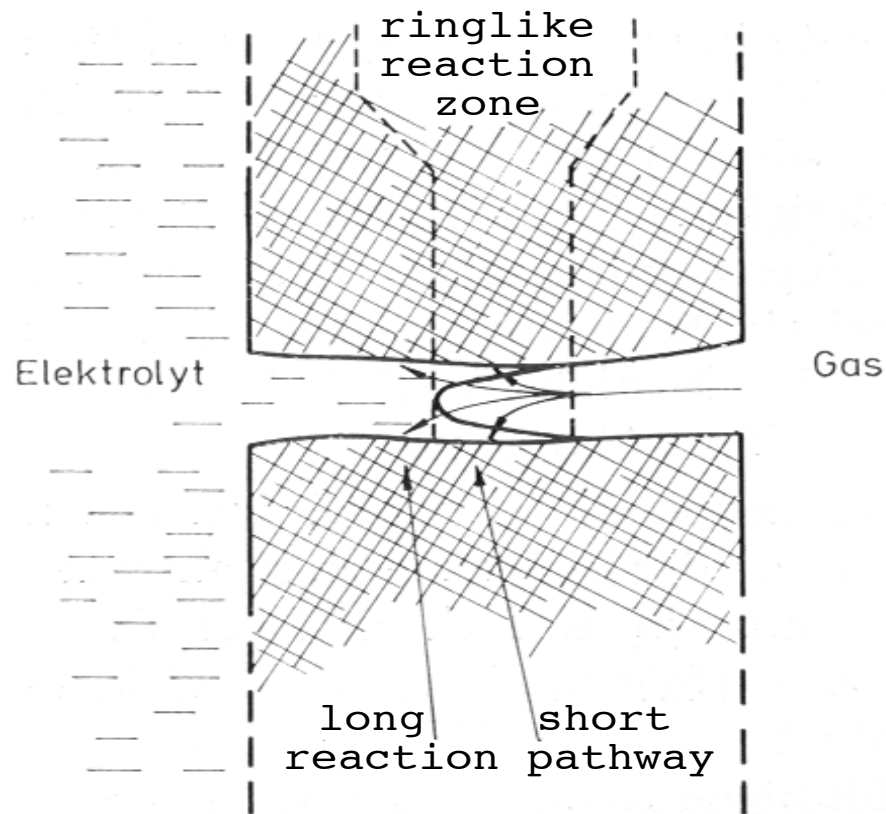

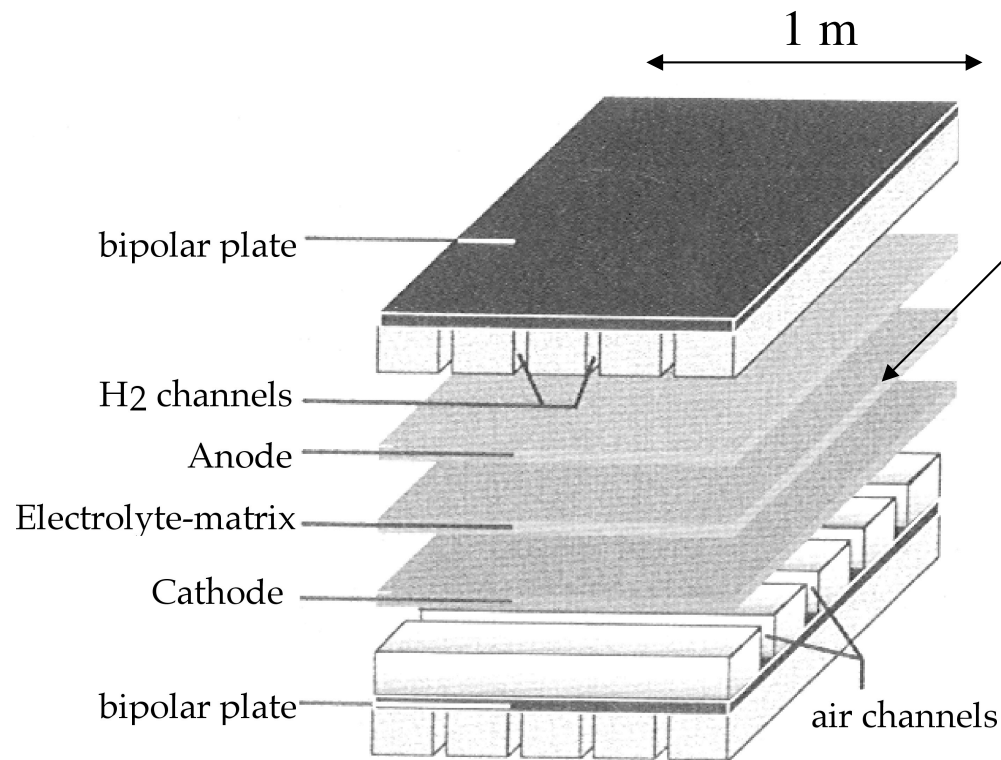

(Source: Ledjeff, 'Brennstoffzellen')

Increase electrode surface :
 → high **current I (A)**

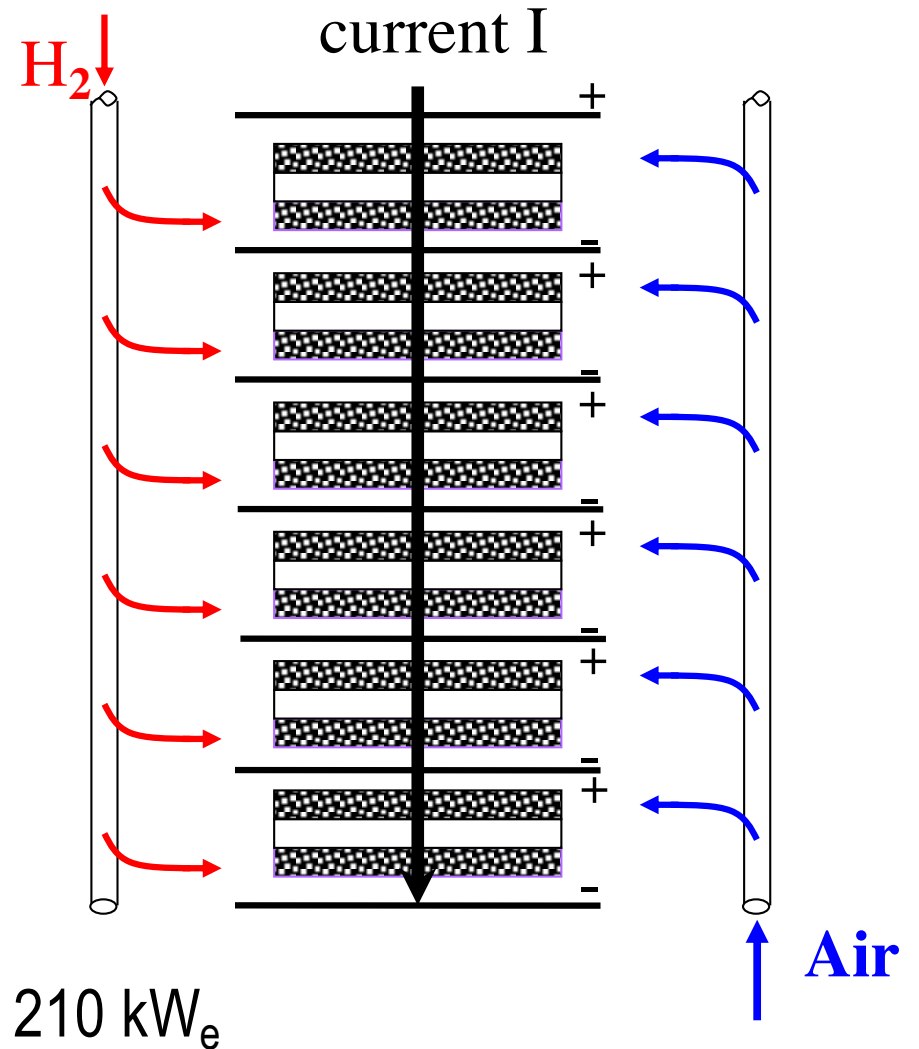

Series connection :
 add up the **voltages (V)**

Electric **power P = V * I**
 f.ex. 100 cells of 1 m² surface

$$70 \text{ V} * 3000 \text{ A} = 210 \text{ kW}_e$$



Units exist from 50 kW_e to several MW_e



Typical size is 200 kW_e or 400 kW_e, operated on natural gas (NG)



(source : Thoma & Renz AG, Basel, CH)

**2. Polymer Membrane FC
Polymer Electrolyte FC
(PEM or PEFC)**

< 1 V

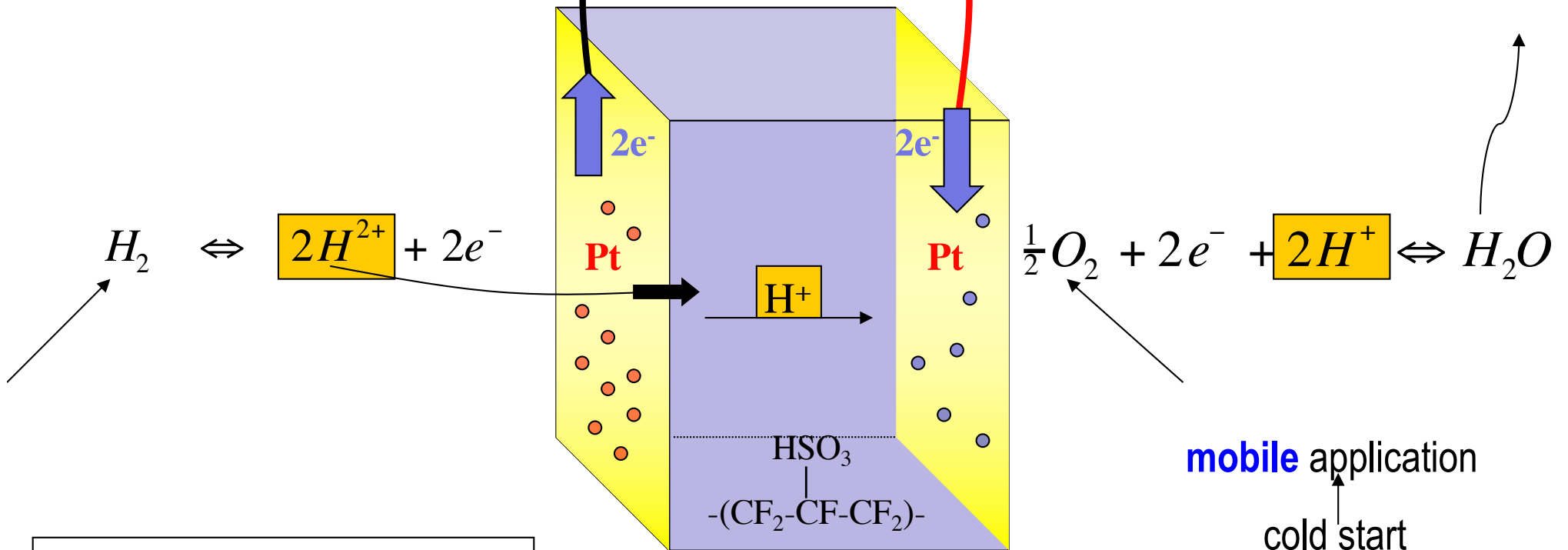
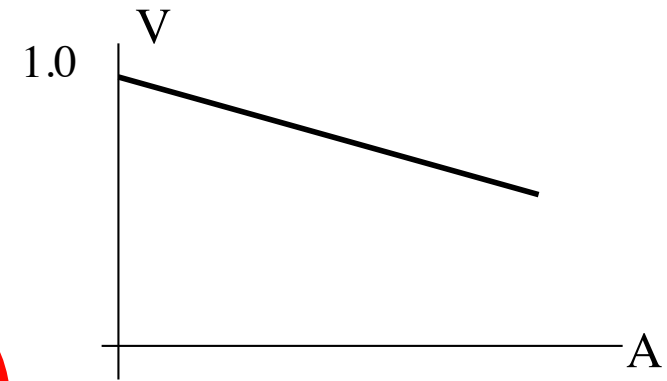

Rem. : also capable to oxidise directly methanol as fuel

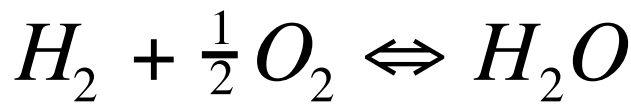

mobile application

cold start

0-80C

polymer membrane (50 μm thin)

series connection (« stack »)

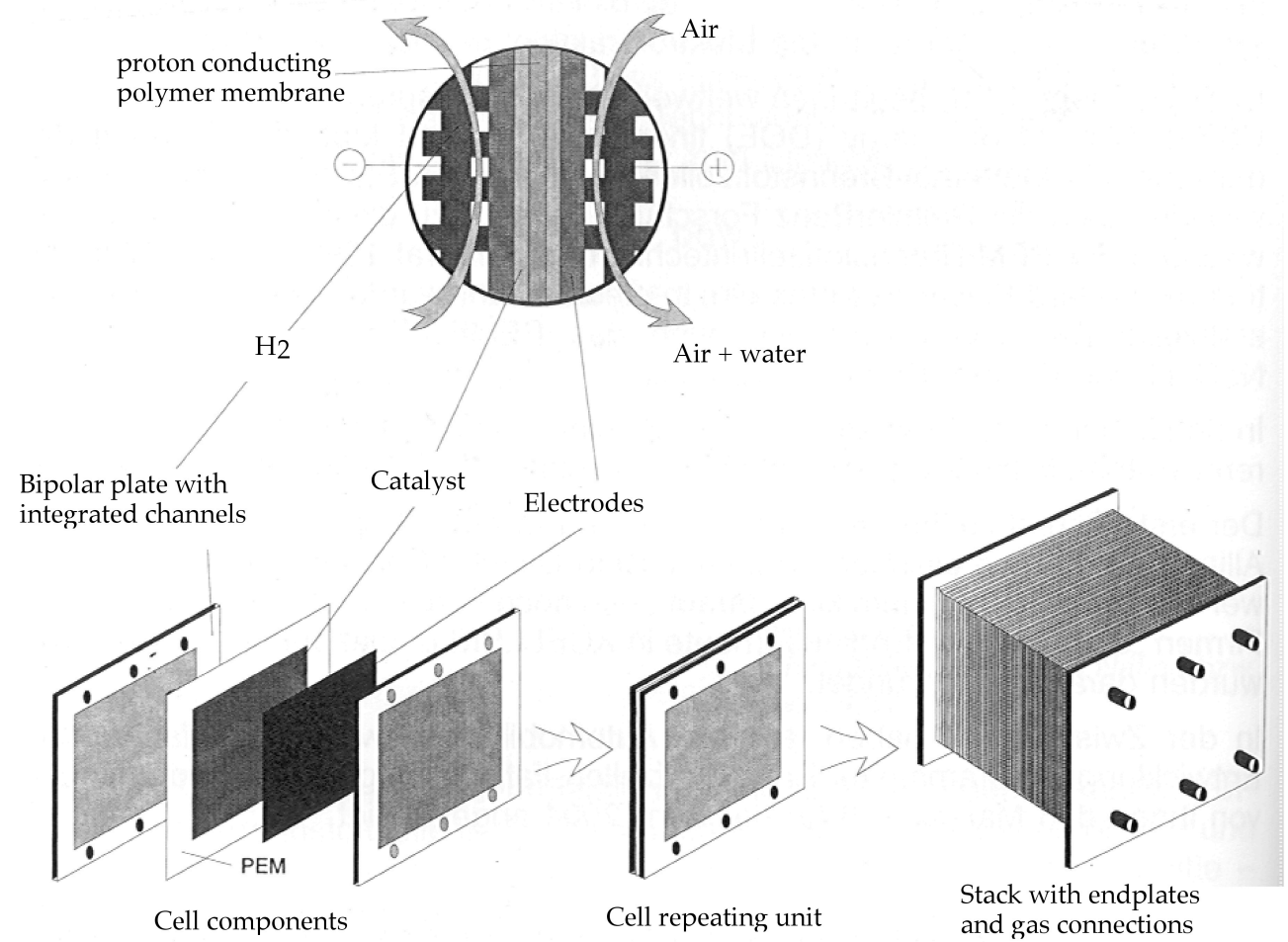
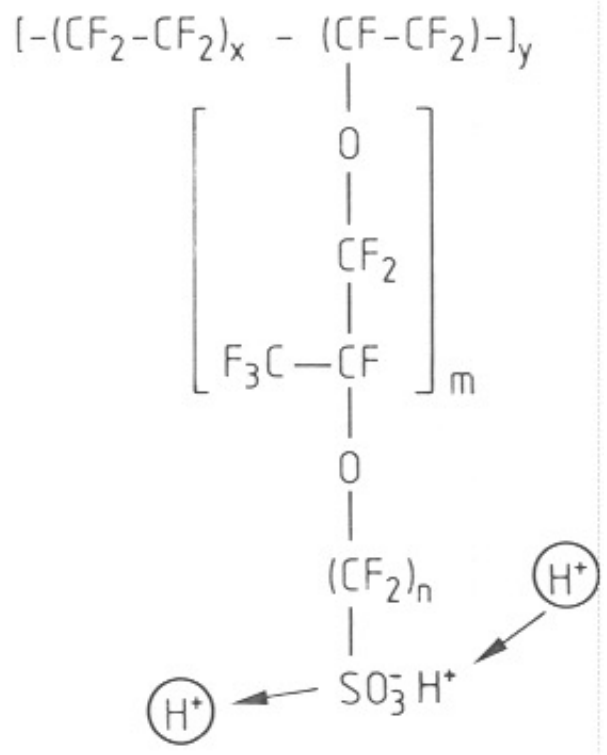

<http://www.youtube.com/watch?v=yowRvfFtMgQ>

'Triple phase boundary' concept

Copied from G.G. Scherer, PSI, European Fuel Cell Forum, Lucerne, Tutorial Course

(shown for cathode)

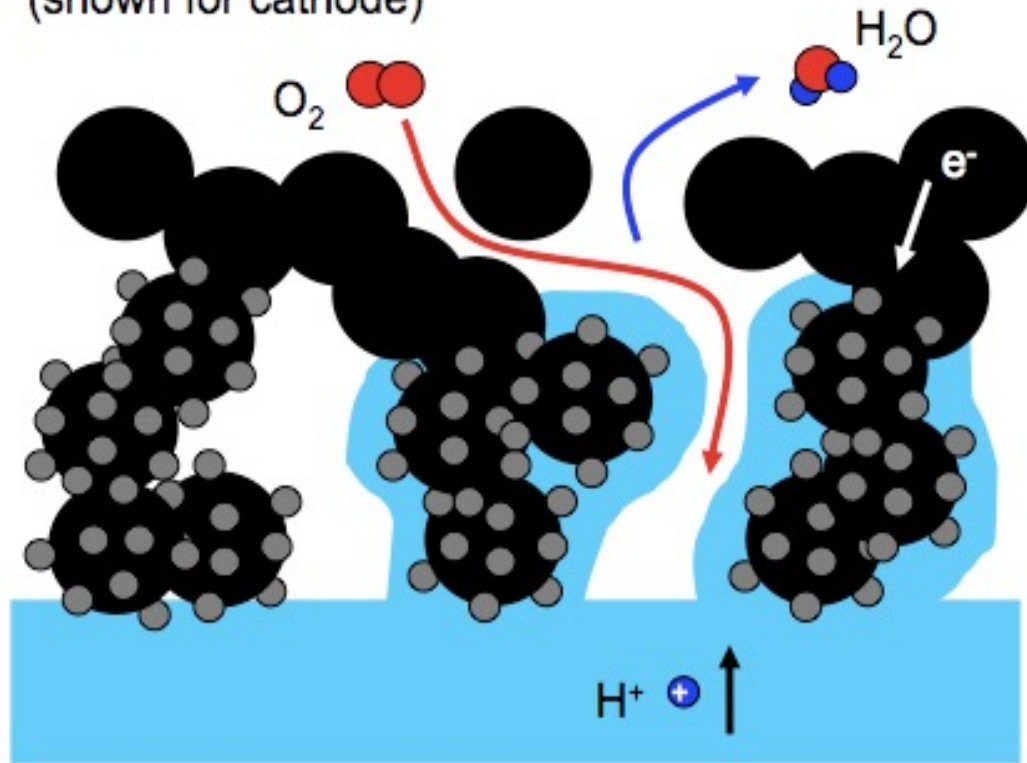

3 phases **must** meet: gas (pores), catalyst (electrons) and electrolyte membrane (ions)

access of:

1. electrons
2. protons
3. reactants / products

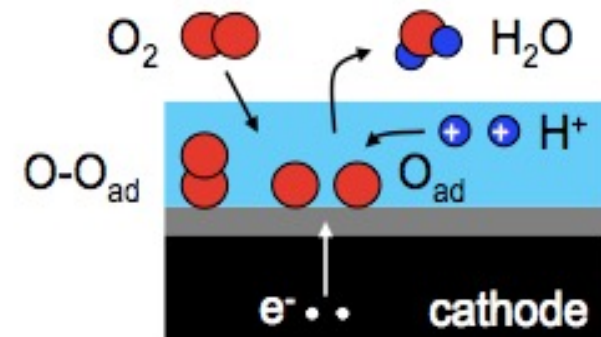
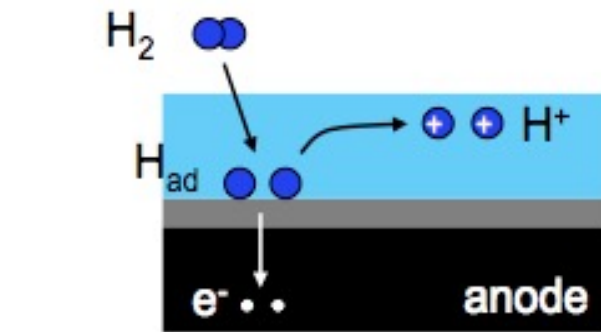

Polymer membrane morphology

bi-continuous nano-phase separated microstructure

- hydrophobic backbone provides mechanical integrity
- proton transport occurs via water filled channels

e.g. Nafion®:

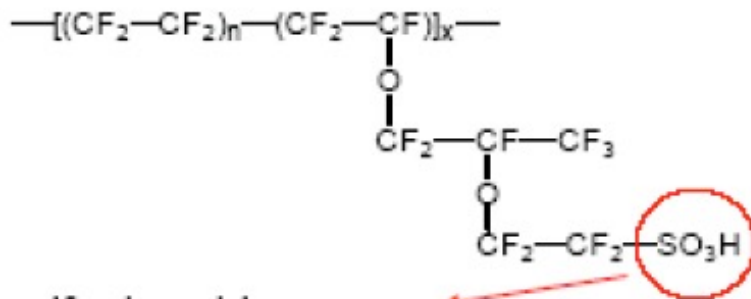

sulfonic acid group:

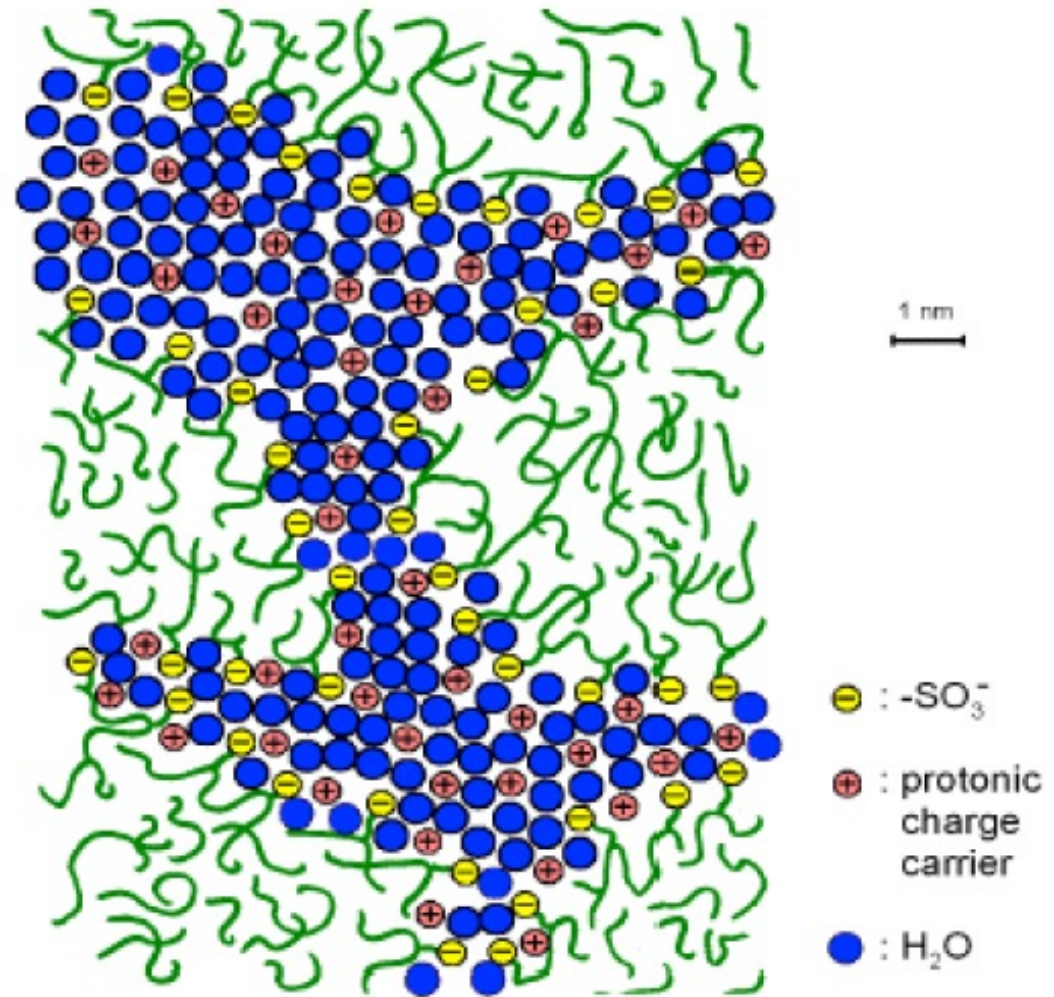
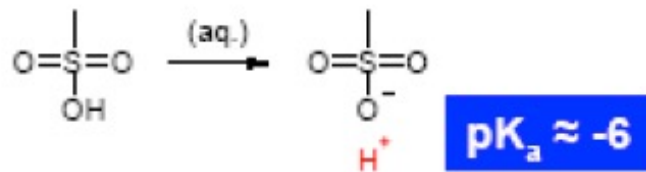

Copied from G.G. Scherer, PSI, Fuel Cell Tutorial, European Fuel Cell Forum, Lucerne

Membrane electrode assembly (MEA)

polymer electrolyte

Pt-catalyst

cell frame / bipolar plate

current collector / gas diffusion layer

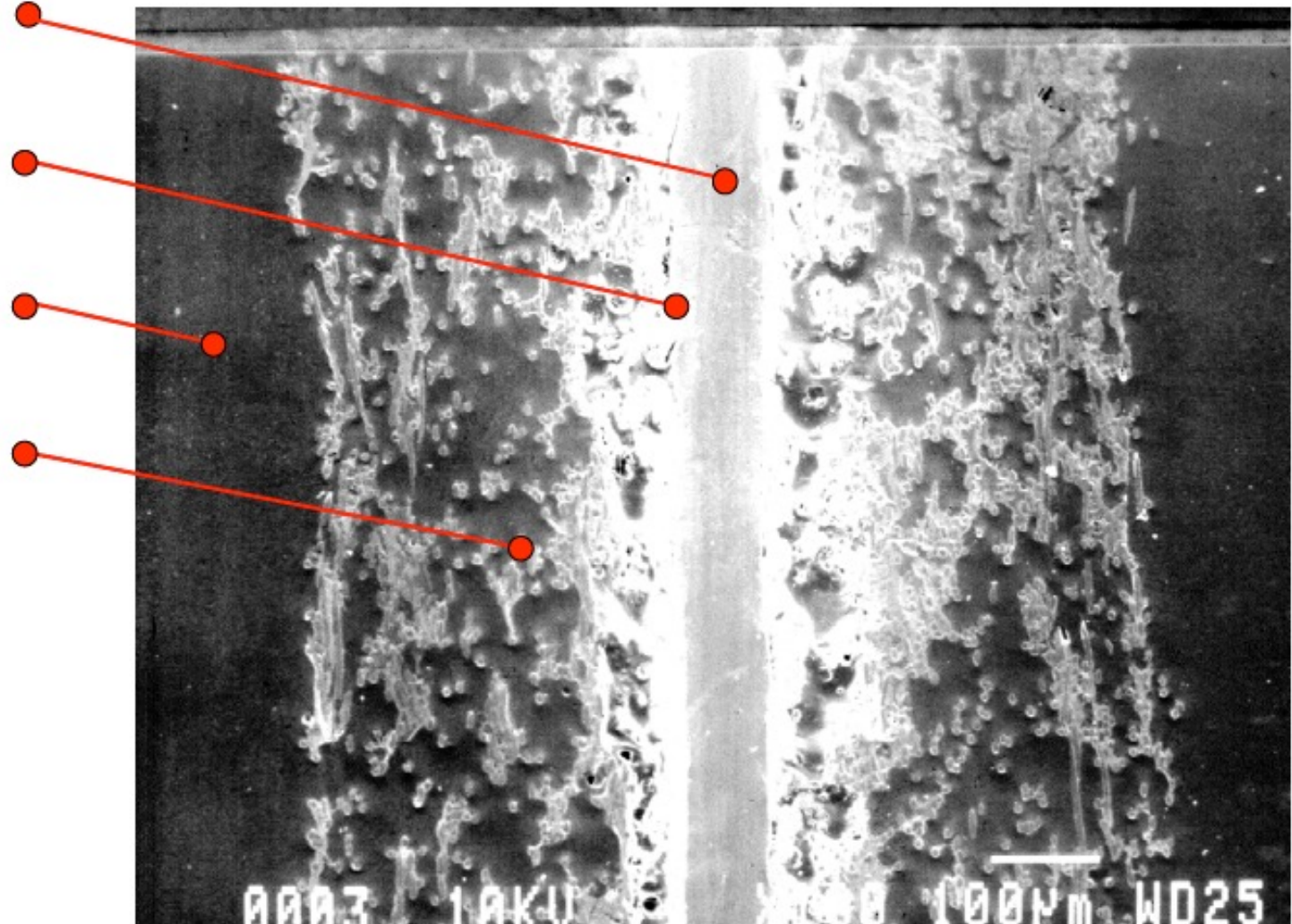

Copied from G.G. Scherer, PSI, Fuel Cell Tutorial, European Fuel Cell Forum, Lucerne

Platinum nano particles supported on carbon particles

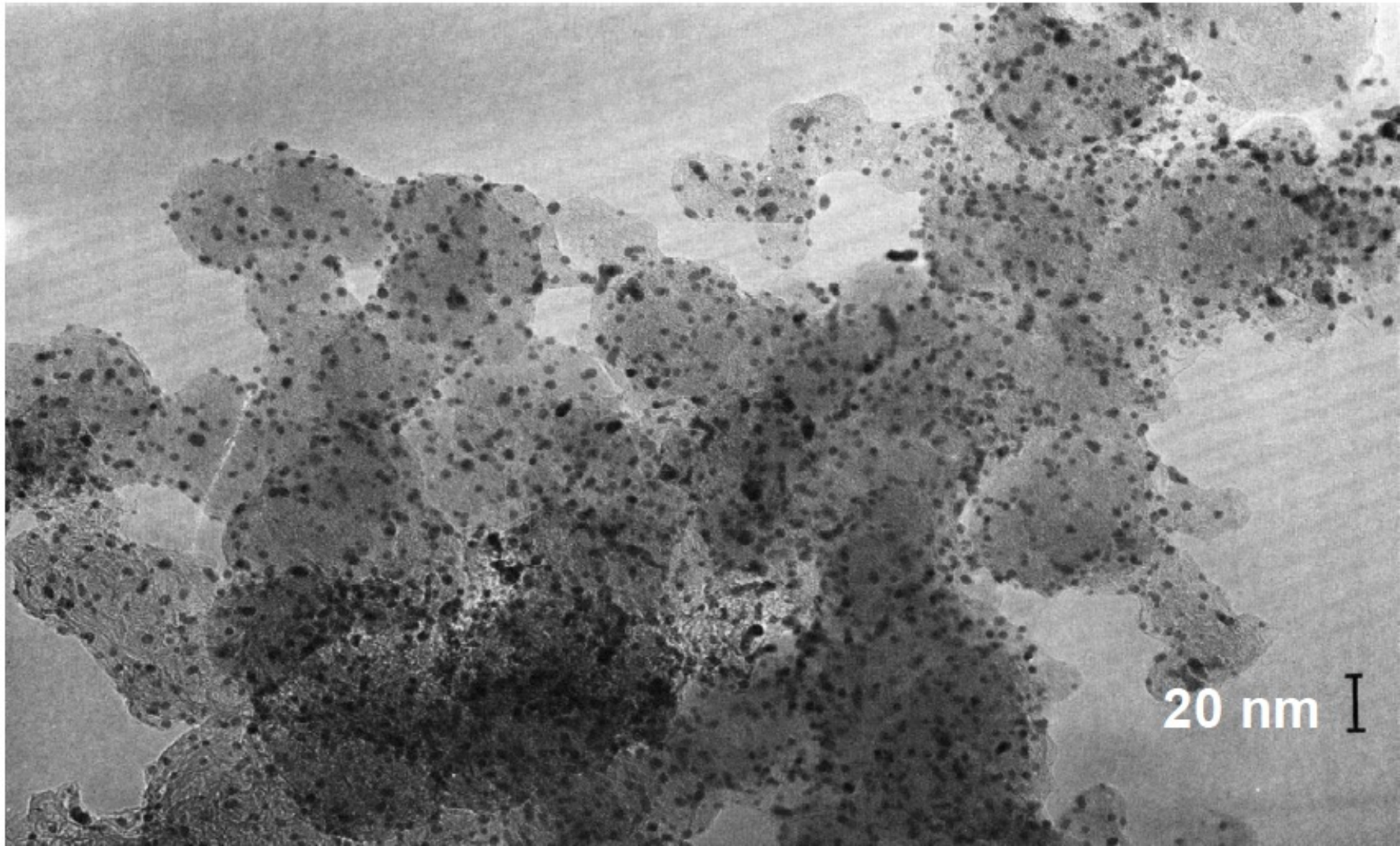

Copied from G.G. Scherer, PSI, Fuel Cell Tutorial, European Fuel Cell Forum, Lucerne

Example of commercial catalyst (3M)

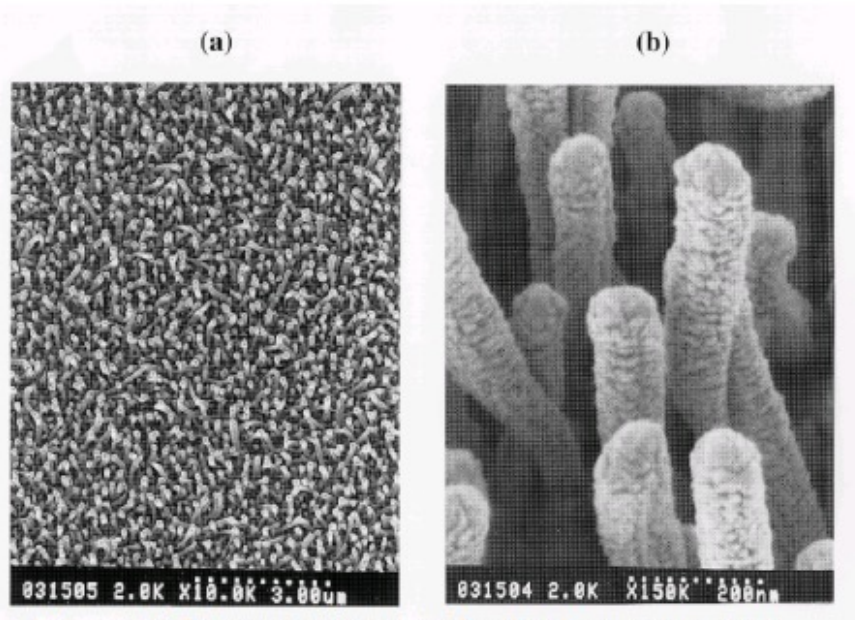

Pt coated nanostructured whisker supports (0.25 mg/cm²), at 10,000 X plan view (left) and 150,000 X, 45° view (right).

Low platinum loading

No ionomer impregnation

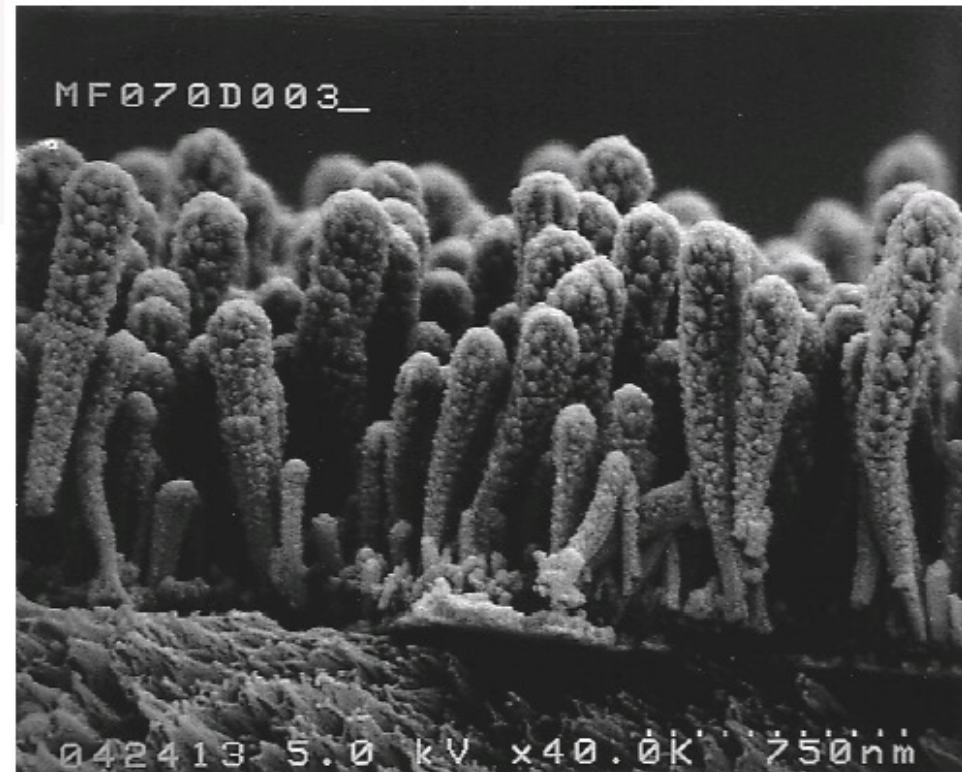

Copied from G.G. Scherer, PSI, Fuel Cell Tutorial, European Fuel Cell Forum, Lucerne

PEFC : critical water management

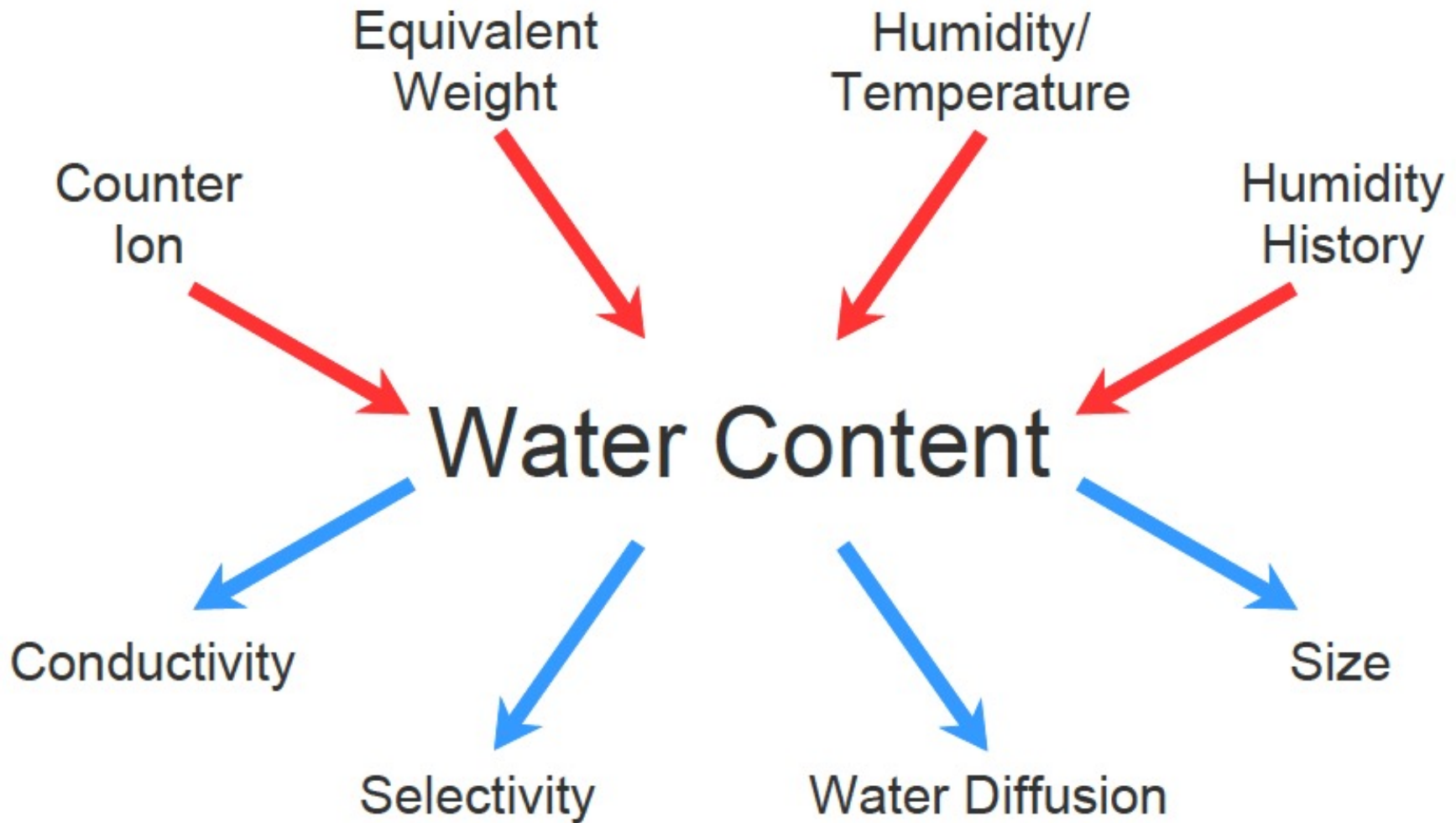

Copied from G.G. Scherer, PSI, Fuel Cell Tutorial, European Fuel Cell Forum, Lucerne



70 kW_e



2 kW_e

5 - 50 W_e

Laptop with fuel cell



Fuel cell camcorder



Professional camera with fuel cell



5 kW_e



Fuel cell power box

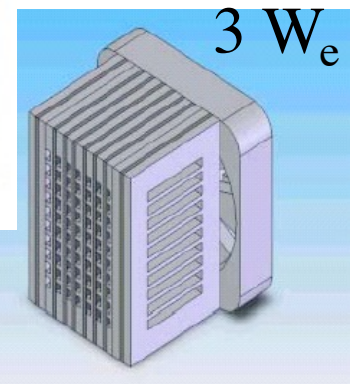

3 W_e

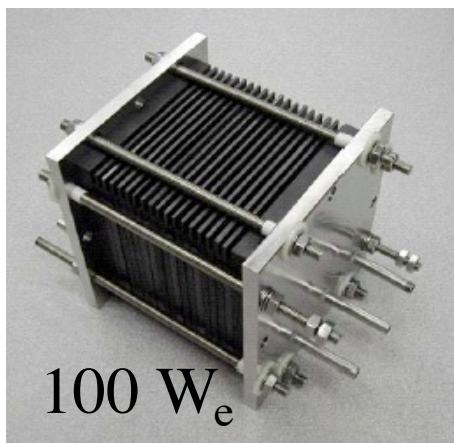

100 W_e

PEFC applications

Daimler fuel cell car (PEFC)

- B-class F-CELL
- 30'000 km test
- 700 bar H₂ floor tank
- 400 km range
- 100 kW, 290 Nm



Toyota Mirai

On the market since January 2015
 Many 1000 vehicles sold.



<https://www.youtube.com/watch?v=vmk15ZjgFXg>

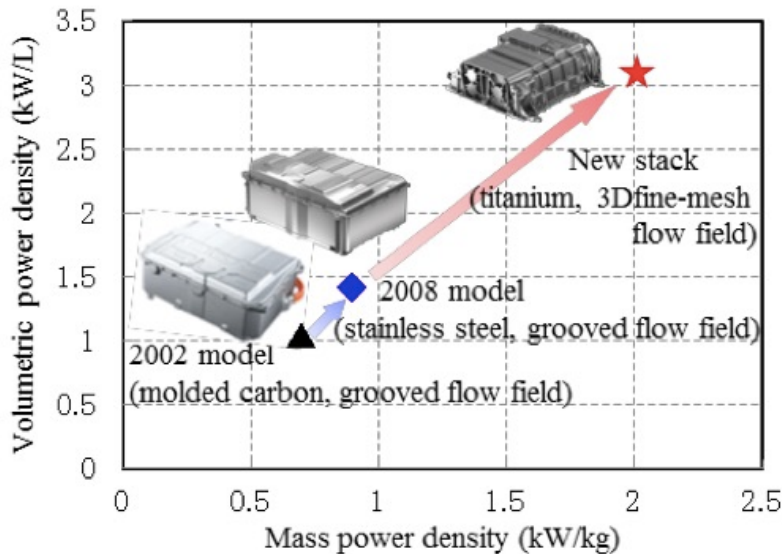

FDC: FC boost converter
 BDC: Battery boost converter

Compact and low-cost
 (fewer layered cells)

FDC with world-leading performance

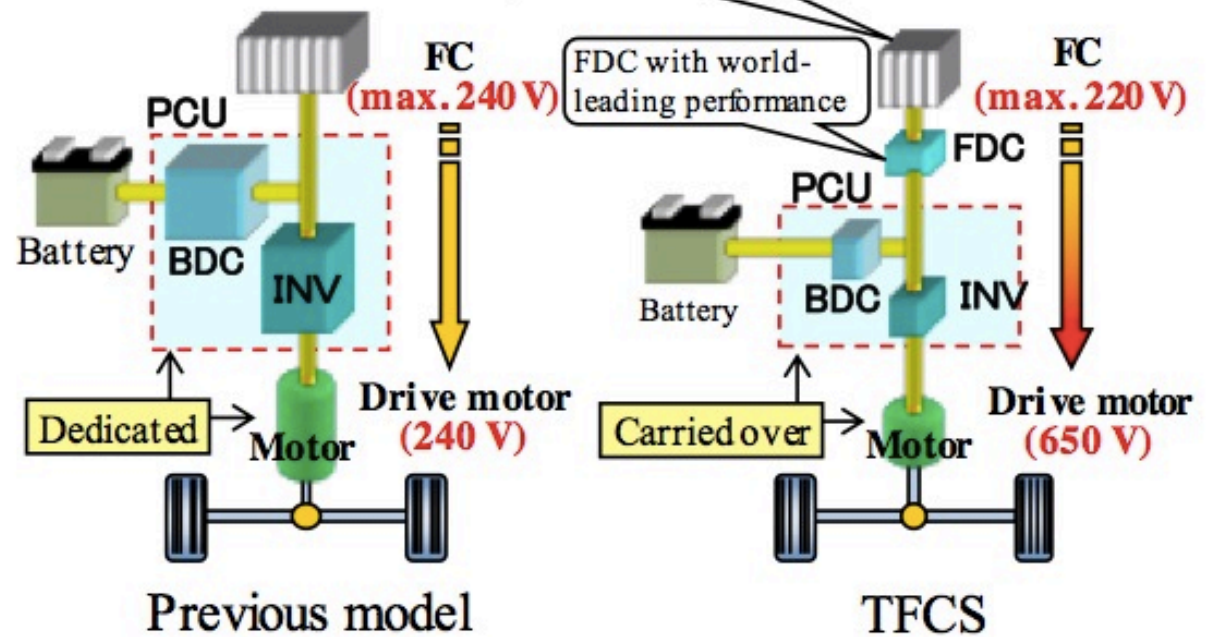

Some facts

- Toyota invested 15 billion Fr in developing the Mirai car
- Hyundai employs 4000 fuel cell system engineers
- A fuel cell car consumes 1 kg H₂ per 100 km
 - 1 kg H₂ = 33 kWh
 - 1 L gasoline = 9 kWh
 - hence this is equivalent to <4L gasoline /100 km
- Cost:
 - H₂ price = 10€/kg
 - Gasoline price = 1.7 Fr/L
 - hence H₂ cost is (already) the same as for a 7L/100km gasoline car

Portable electronics: direct methanol PEFC 0.1 W

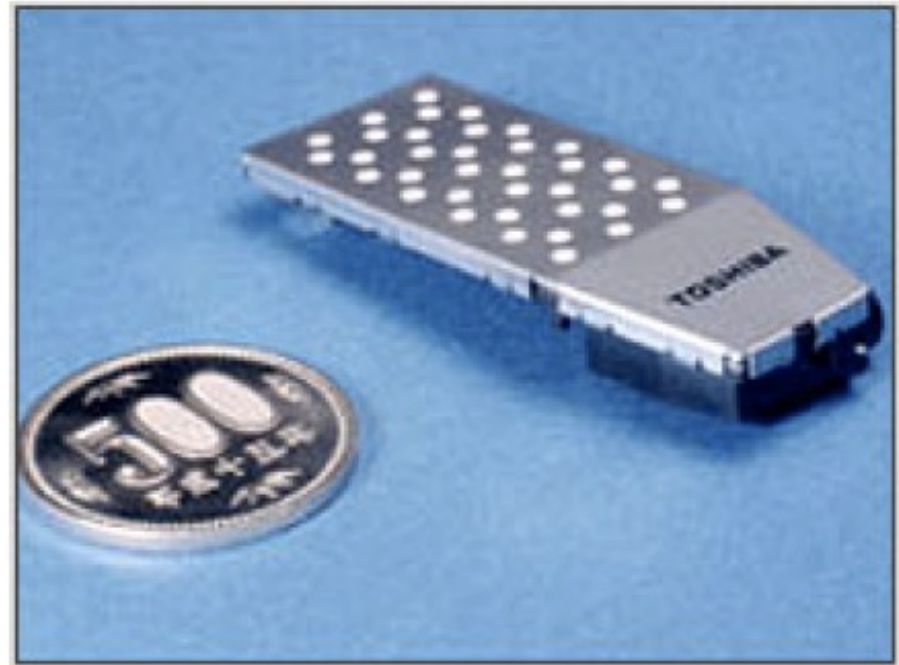

(Copied from G.G. Scherer, Tutorial, European Fuel Cell Forum, Lucerne)

Comment: (1) H⁺ conduction

- The 2 former **fuel cell types** use **proton (H⁺) conduction**, in a liquid (acid) or a wet membrane (polymer)
- They operate at 200C (acid) or below 100C (polymer)
- At such **low temperature**, the **only fuel** reactive enough to be (electrochemically) oxidized is **hydrogen (H₂)**
 - ...and methanol (MeOH), but with much reduced power output
- Moreover, the **only electrodes** capable to catalyze this reaction ($\text{H}_2 + \frac{1}{2}\text{O}_2 \rightarrow \text{H}_2\text{O}$) at such low temperature are the **noble metals** (Pt-group) – cf. activation overpotential (charge transfer at cathode) and exchange current density j_0

=> limited to H₂ and Pt

Comment: (2) oxygen conduction

- The following **3 fuel cell types** use a form of **oxygen ion conduction**
- Two use a ceramic resp. molten salt conductor, which operate at high temperature (>600C)
- At such **high temperature, other fuels than H₂** become reactive enough for (electrochemical oxidation) (CO, CH₄,...)
- Moreover, high temperature is favorable for fast electrode kinetics, making **cheaper catalysts** than noble metals possible (Ni, oxides,...)

=> possible with hydrocarbons, on Ni catalyst

3. Alkaline Fuel Cell (AFC)

< 1 V

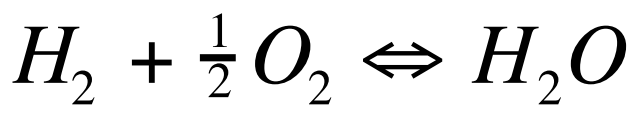
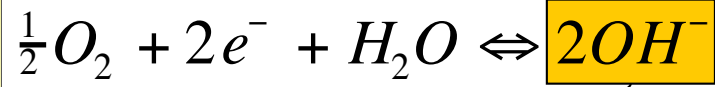
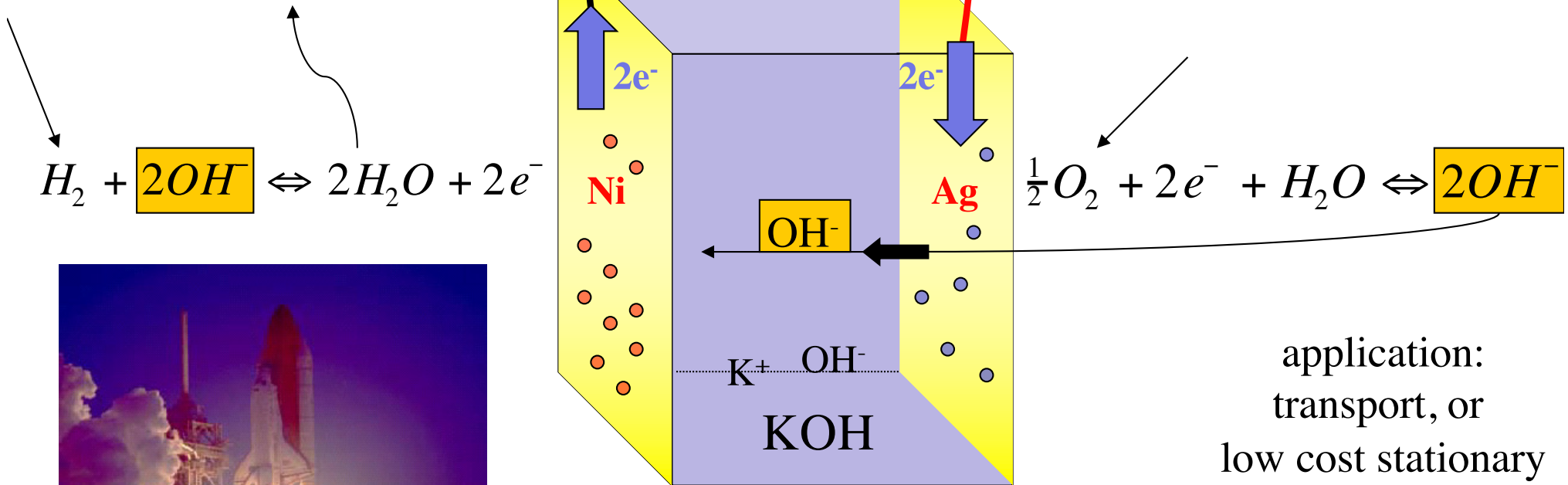
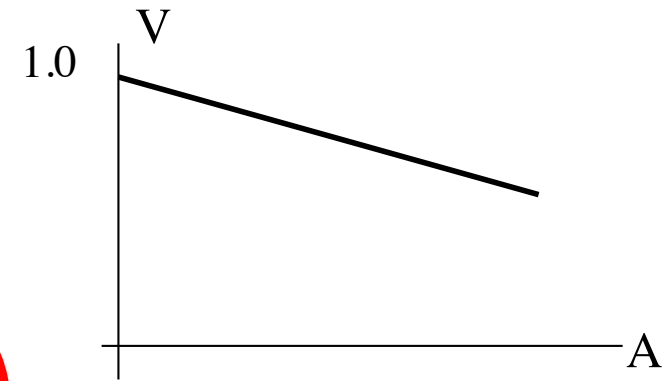

application:
transport, or
low cost stationary

80C



on-board 12 kW_e

Alcaline FC

- requires pure H₂, air without CO₂ (carbonatisation of KOH electrolyte)
- ...but CO₂ is easily scrubbed out
- cheaper catalysts possible, as alternative to Pt (Ni anode, Ag cathode)
- robust
- can be mass-manufactured
- 60% efficiency based on H₂
 - Varta batteries (D)
 - Siemens (transport)
 - Univ. Graz (AUT, Prof. Kordesh)
 - **AFC Energy (UK) => 0.5-1 MWe systems**
(market: H₂ byproduct from NaCl salt electrolysis)

AFC example from Apollo Spacecraft (1970'ies)

Manufacturer: Pratt & Whitney Aircraft Division of United Aircraft Corporation

3 fuel cells stacks on board

pure liq H_2 and O_2

operating T $206^\circ C$

efficiency 70% !

31 cells in series operating at 27-31 V for a power output of 0.56-1.42 kW, and a max of 2.3 kW (each stack)

Construction materials: Ti, stainless steel, Ni

Electrodes: Ni with Pt catalyst

(no limit on noble metal use for space application!!)

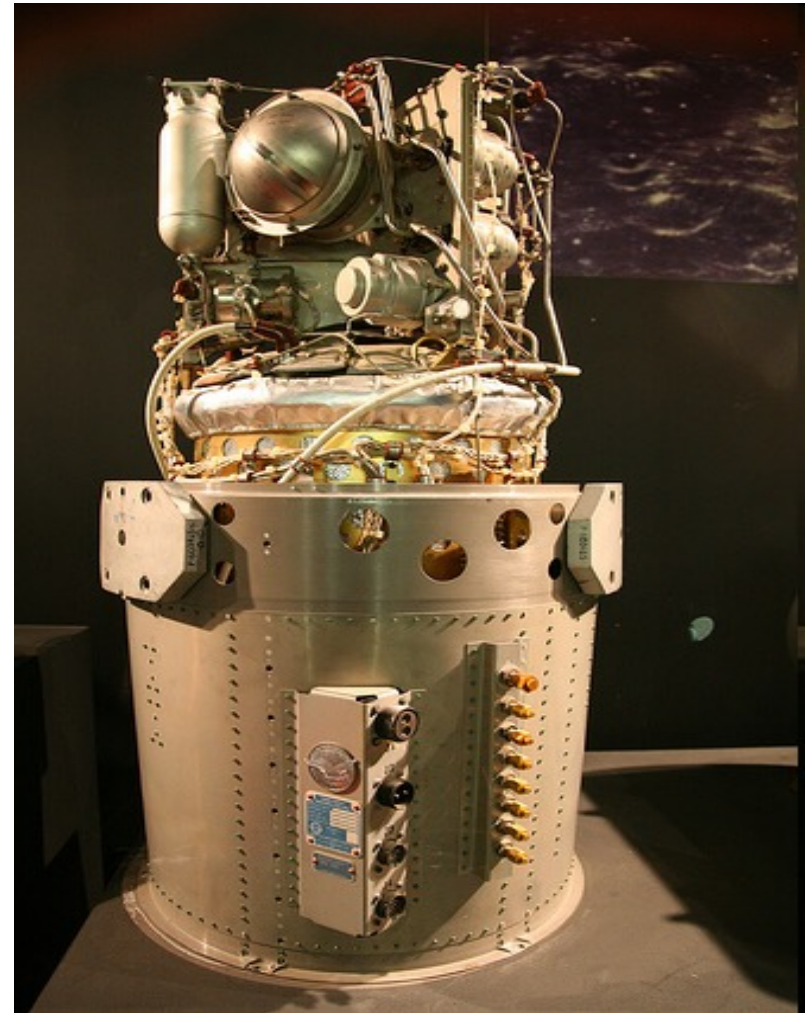

AFC system

characterised by a *circulating electrolyte*

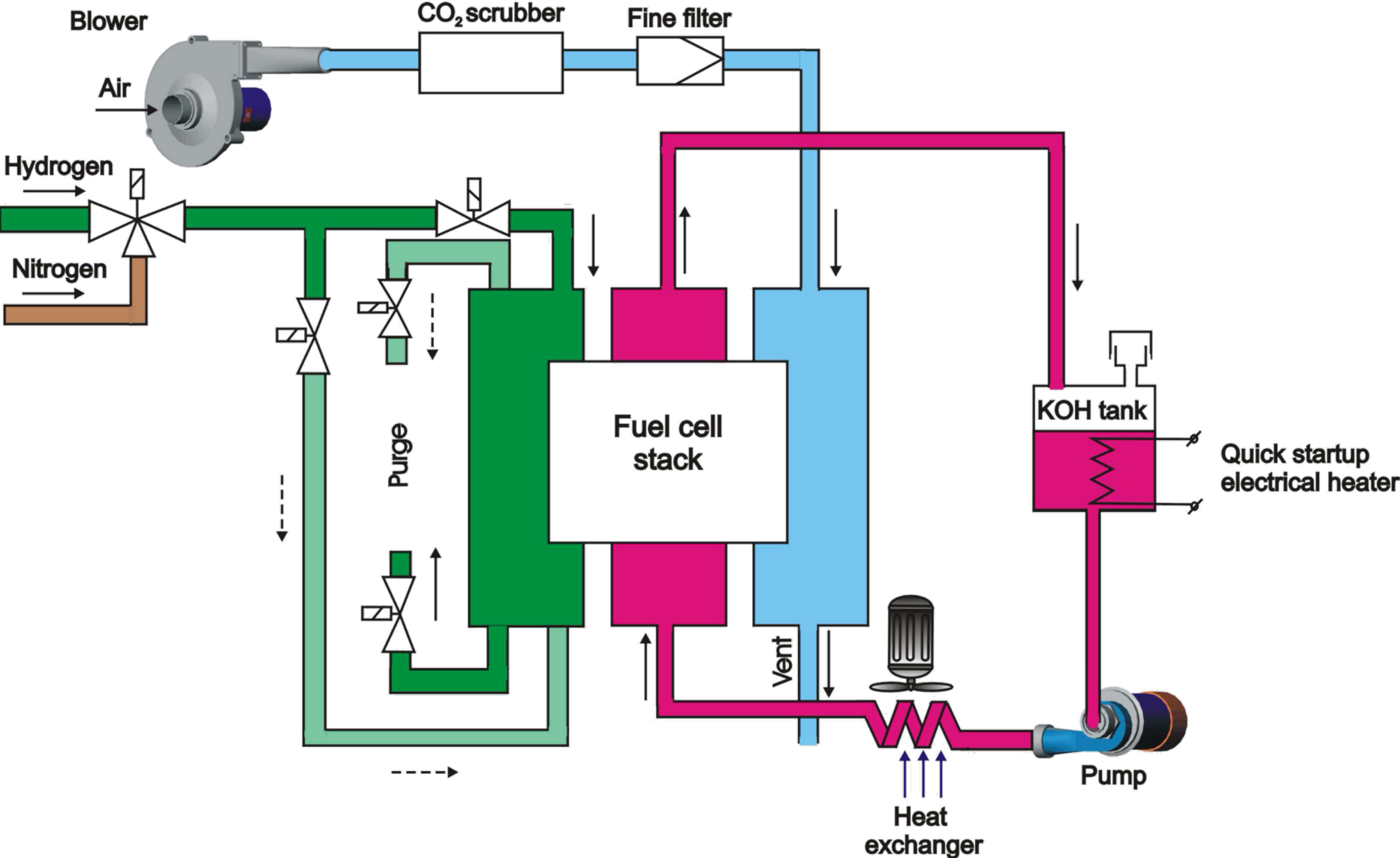

4. Solid Oxide Fuel Cell (SOFC)

< 1 V

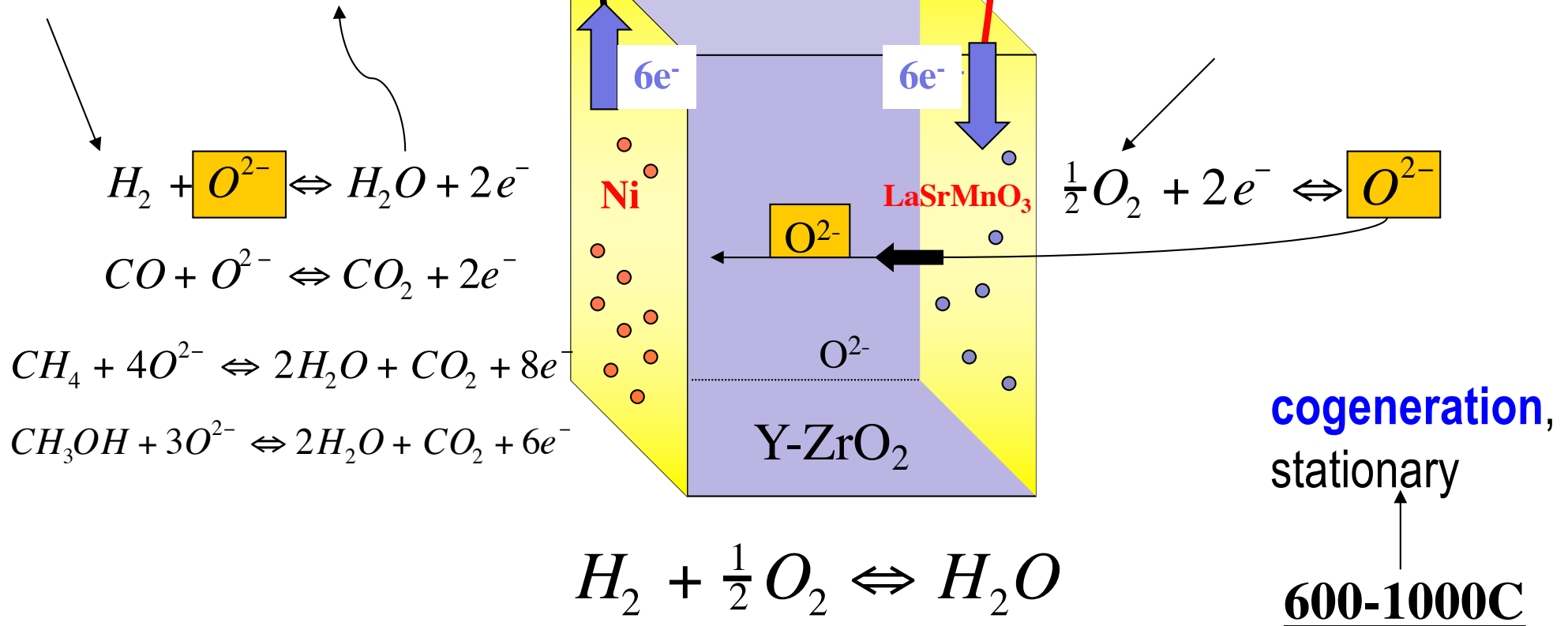
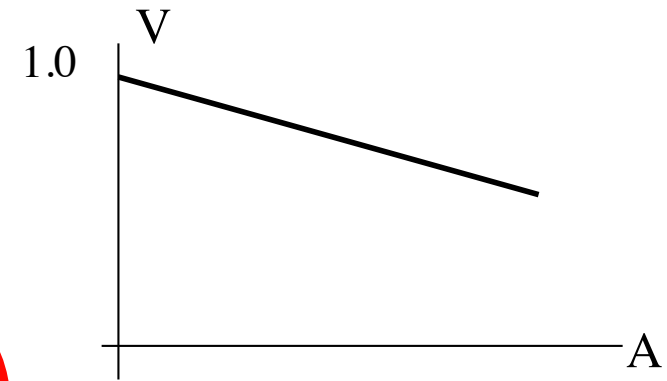

Animated SOFC

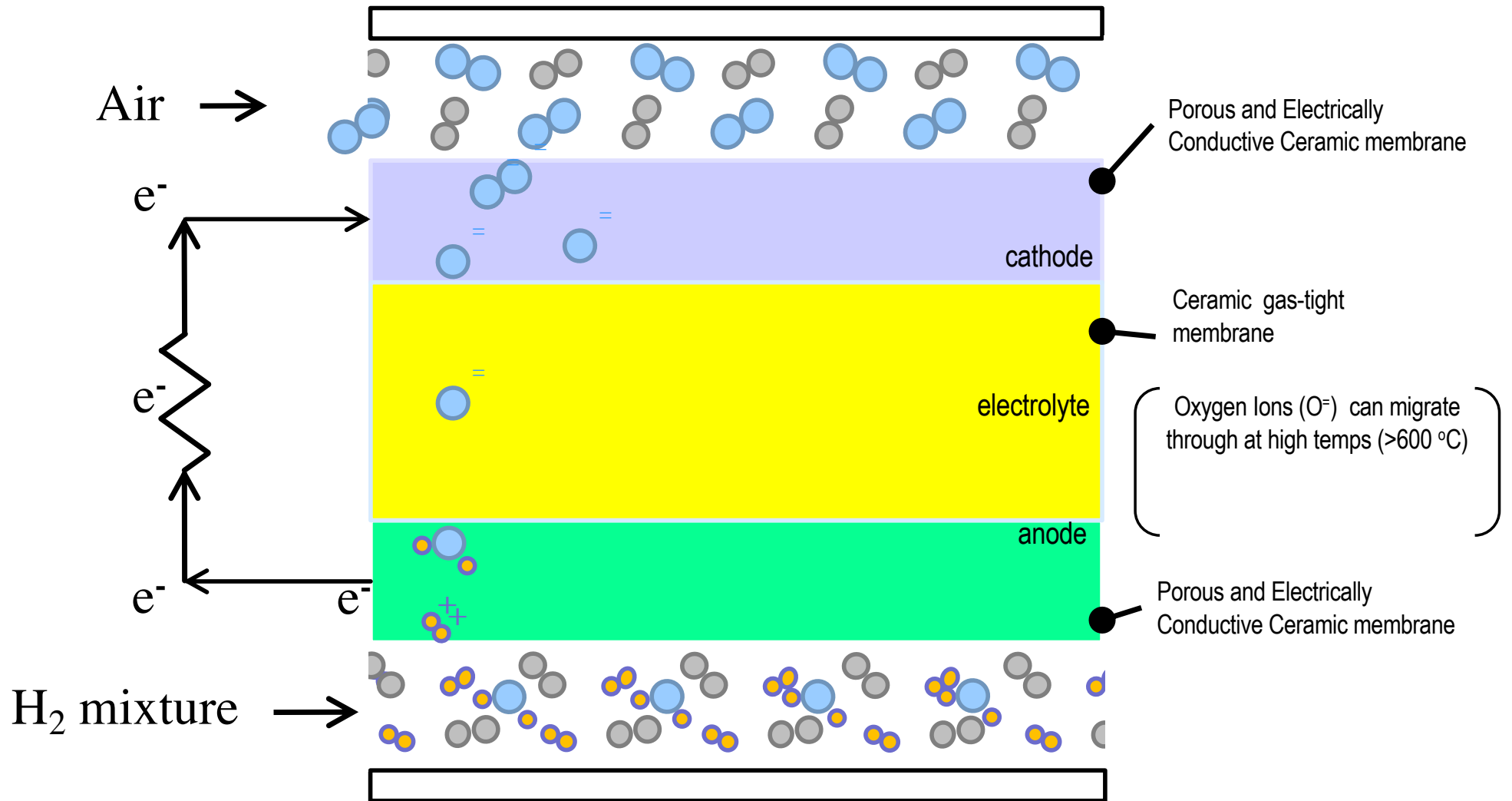

SOFC interfaces detail

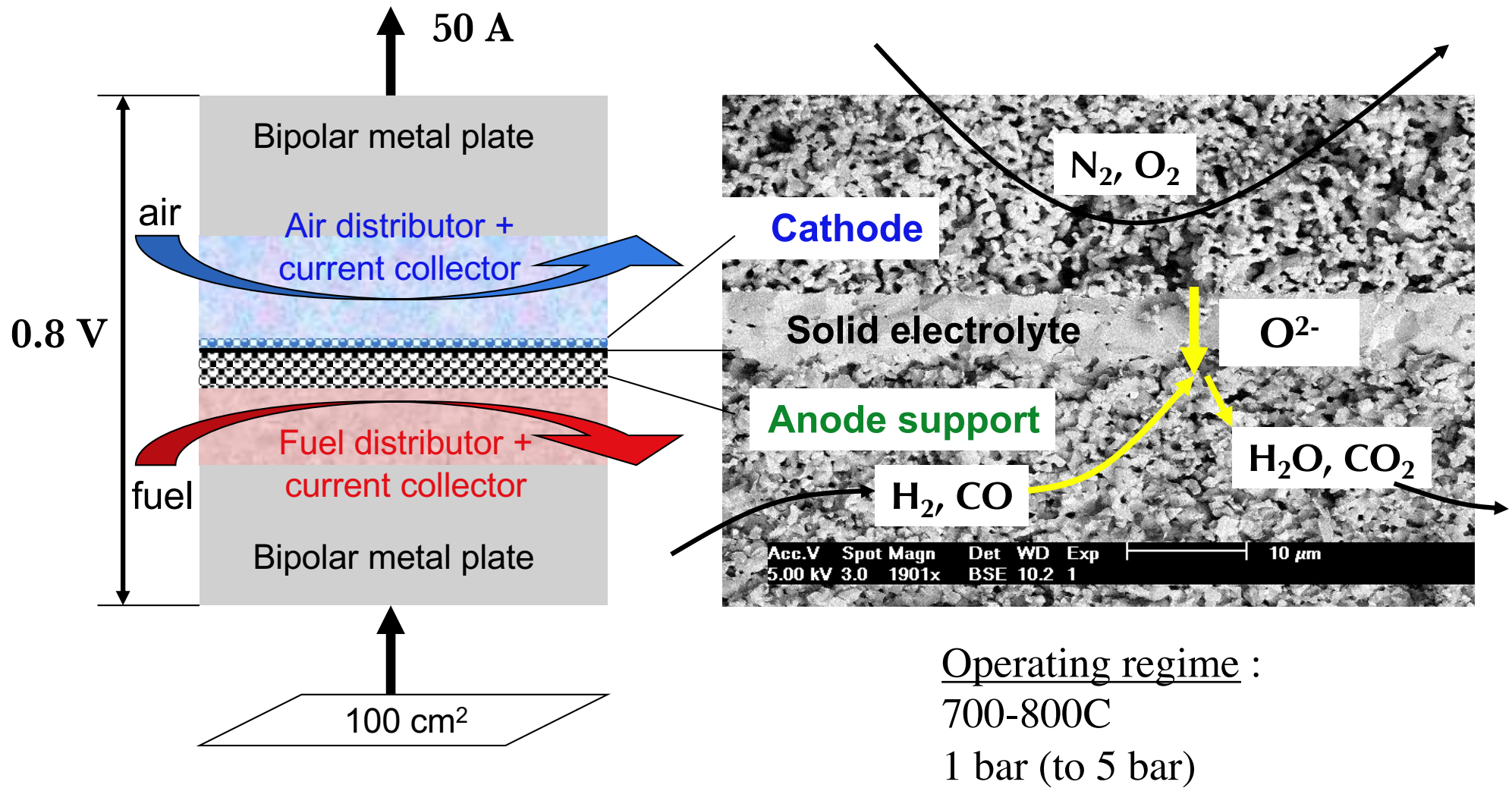



TOHO
GAS
1 kW_e

Kansai
Electric
3 kW_e

FZJülich (D)

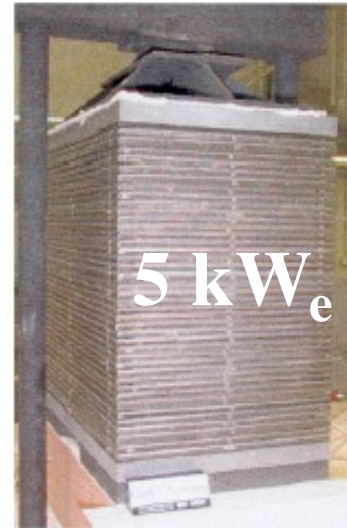
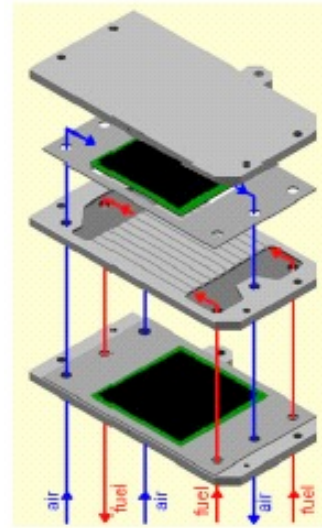
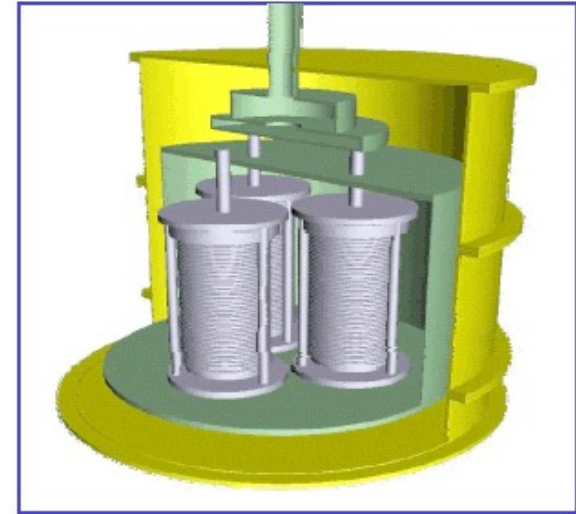

200 kW_e

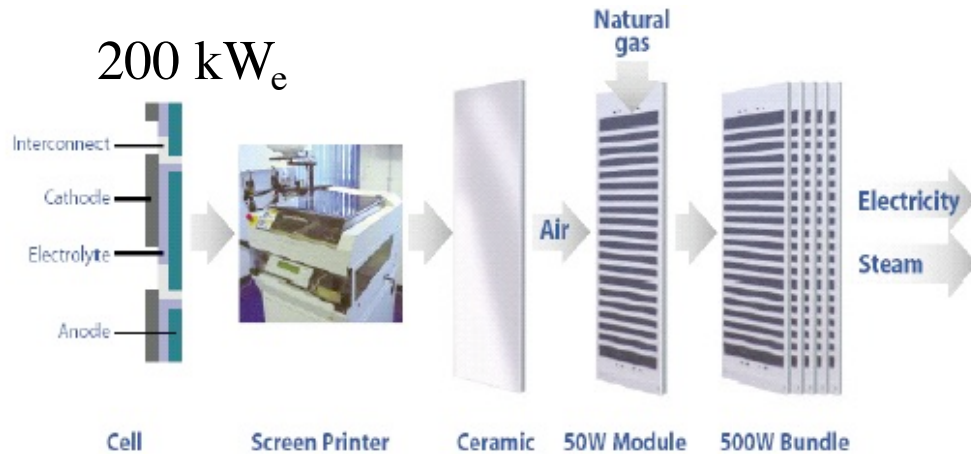

RollsRoyce Power (UK)

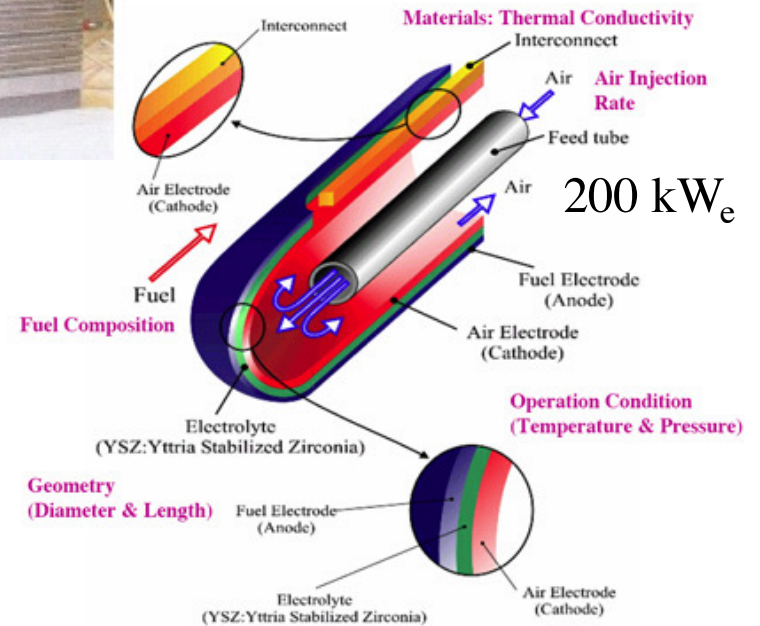

Copyright (C) K. Suzuki

Siemens-Westinghouse

2 kWe net 63% ac efficient SOFC system



Performance			
	Min	Optimum	Max
Electrical Output	500 W	1500 W	2000 W
Electrical Efficiency	36 %	60 %	57 %
Thermal Output	Approx. 400 W*	Approx. 540 W*	Approx. 1000 W*
	* Based on exhaust gas cooled to 30 °C		
Power Output Modulation	From 0 % to 100 %		
System Efficiency	60 % to 85 % Depending on heat and condensate recovered		

<https://www.dailymotion.com/video/x2p2rmd>

Multi-100 kWe SOFC



www.bloomenergy.com/products

Inputs	
Fuels	Natural Gas, Directed Biogas
Input fuel pressure	15 psig
Fuel required @ rated power	0.661 MMBtu/hr of natural gas
Water required (for startup only)	120 gallons municipal water
Outputs	
Rated power output (AC)	100 kW
Electrical efficiency (LHV net AC)	> 50%
Electrical connection	480V @ 60 Hz, 4-wire 3 phase
Physical	
Weight	10 tons
Size	224" x 84" x 81"
Emissions	
NOx	< 0.07 lbs/MW-hr
SOx	negligible
CO	< 0.10 lbs/MW-hr
VOCs	< 0.02 lbs/MW-hr
CO ₂ @ specified efficiency	773 lbs/MW-hr on natural gas, carbon neutral on Directed Biogas

SOFC characteristics

- tubular : robust (>12 yr proven lifetime), but expensive
goal = few MWe in a hybrid cycle with a micro-gasturbine
- planar : proven lifetime 70'000 h, with **mass-manufacturing** potential;
typically 1-10 kW_e modular units, demonstrated up to MWe
- **60% η_{el}** achieved for both designs
- fuel : NG, LPG, diesel, biogas, NH₃, alcohols, wood gas,...
- **Materials challenges** :
 - FeCr steel interconnect corrosion
 - electrode poisoning from CrO_x steel vapors
 - anode (Ni) reoxidation (=> NiO : expansion) during operation
 - differential thermal expansion, layer delaminations
 - imperfect sealing (leaks)
 - electrode microstructure coarsening, e.g. Ni particle growth
 -

5. Molten Carbonate fuel cell (MCFC)

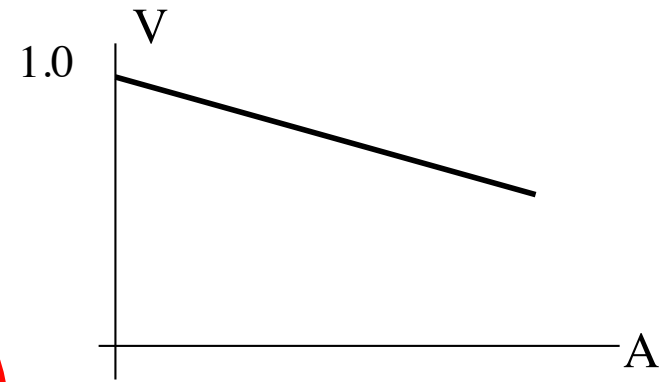

< 1 V

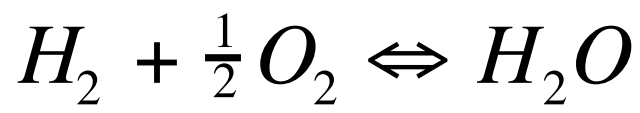
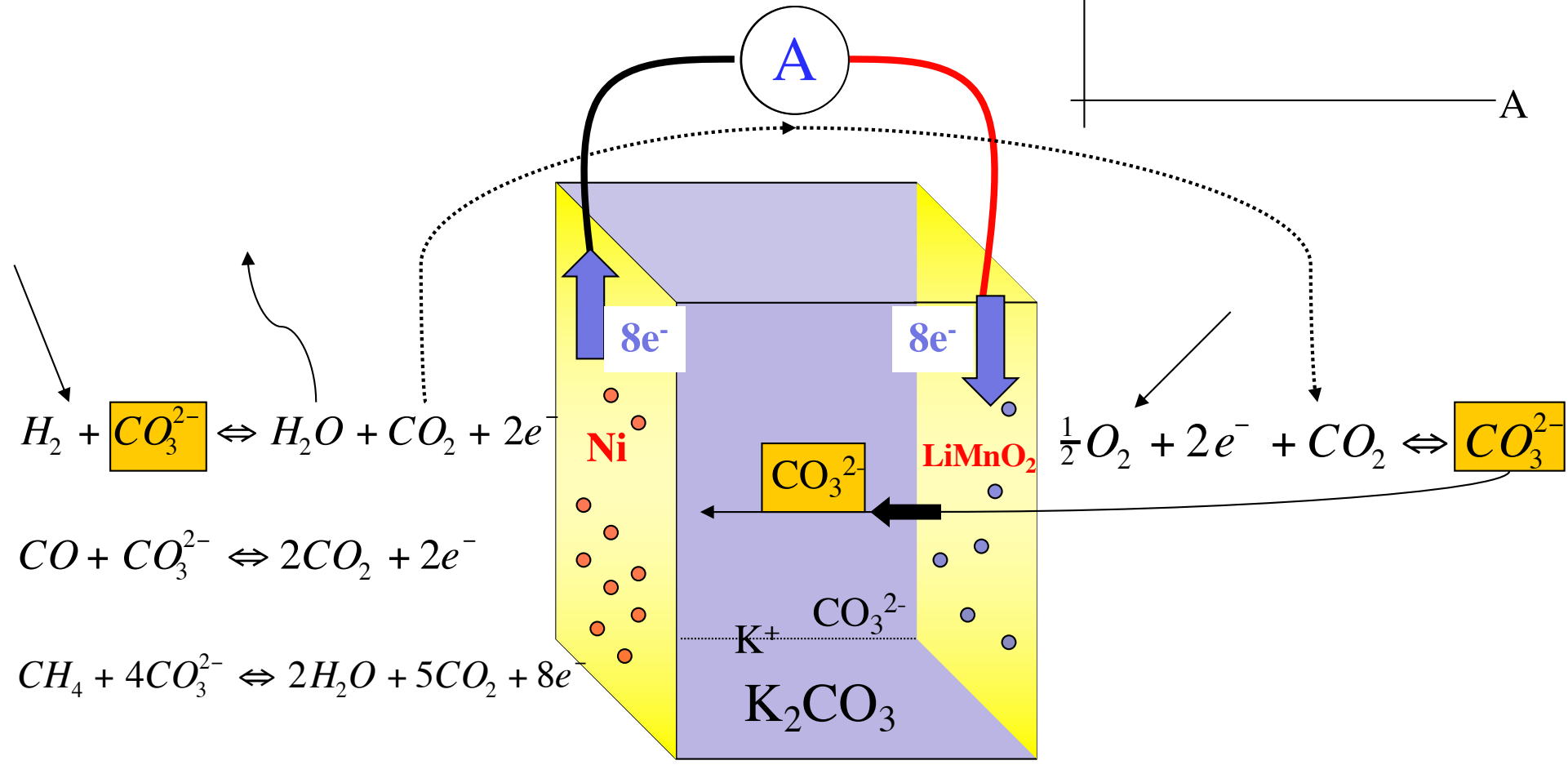

650° C

Photos courtesy of: FCE, AFC, MTU, NEDO, KEPRI

23 May 2003
LADWP-Terminal Island

Fuel Cell Energy



Rhon-Klinikum Hospital (MTU)
Bad Neustadt & Bad Berka,
Germany



Ansaldo Fuel Cells S.p.A.

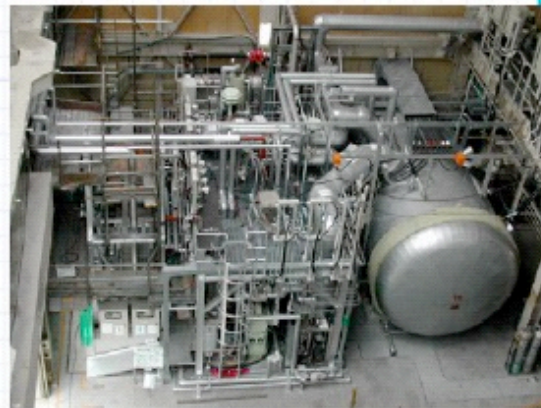

Full View of 300kW-class Compact System
in KAWAGOE Test Station

NEDO



MCFC cogeneration units of 250 kW_e - 1 MW_e

MCFC design & materials

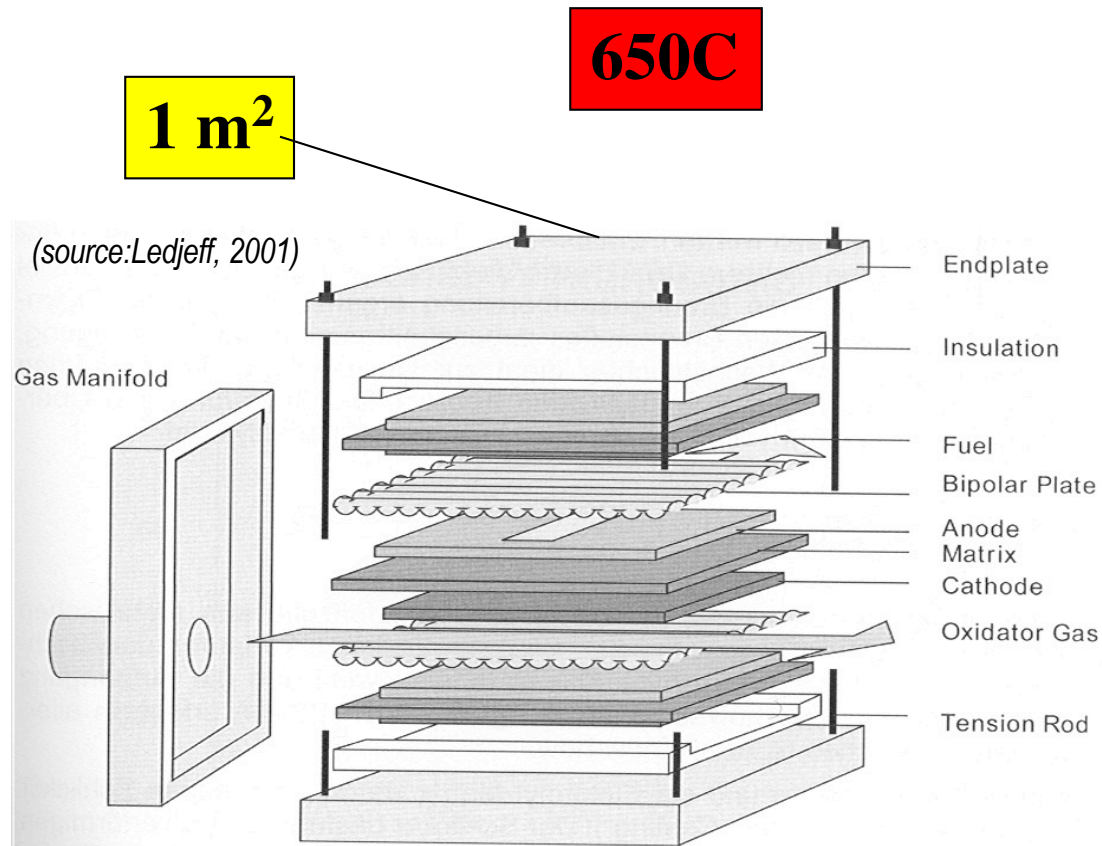

- electrolyte = Li_2CO_3 or Na_2CO_3 mixed with K_2CO_3 , molten at 600-700° C, in a porous ceramic matrix of LiAlO_2
- anode : NiCr or NiAl
- cathode : Li-doped NiO
- interconnection : stainless steel

- CO_2 recirculation imposes a minimal size on the system (250 kW_e)
- 4 modules are combined to one 1 MWe unit etc.

MCFC characteristics

- high $T_{\text{operation}}$ allows thermal integration of fuel processing
- η_{el} 47% at 100 kWe
- goal: 55% at 1 MWe
- CC with μ -turbine : 56% @ 300 kWe
- market = 0.5-3 MWe cogeneration
- NG, coal gas, esp. **biogases**

Limitations :

- **steel corrosion** by molten salt
- gradual NiO **cathode dissolution** in the electrolyte (causing short-circuit); this explains why the electrolyte is thick (1 mm) => short-circuiting is “delayed” until several years ...
- anode **creep** (**stack weight!**)
- cost :\$4000/kW

The 5 FC types (summarised)

(according to $T_{\text{operation}}$ and the ionic conductor)

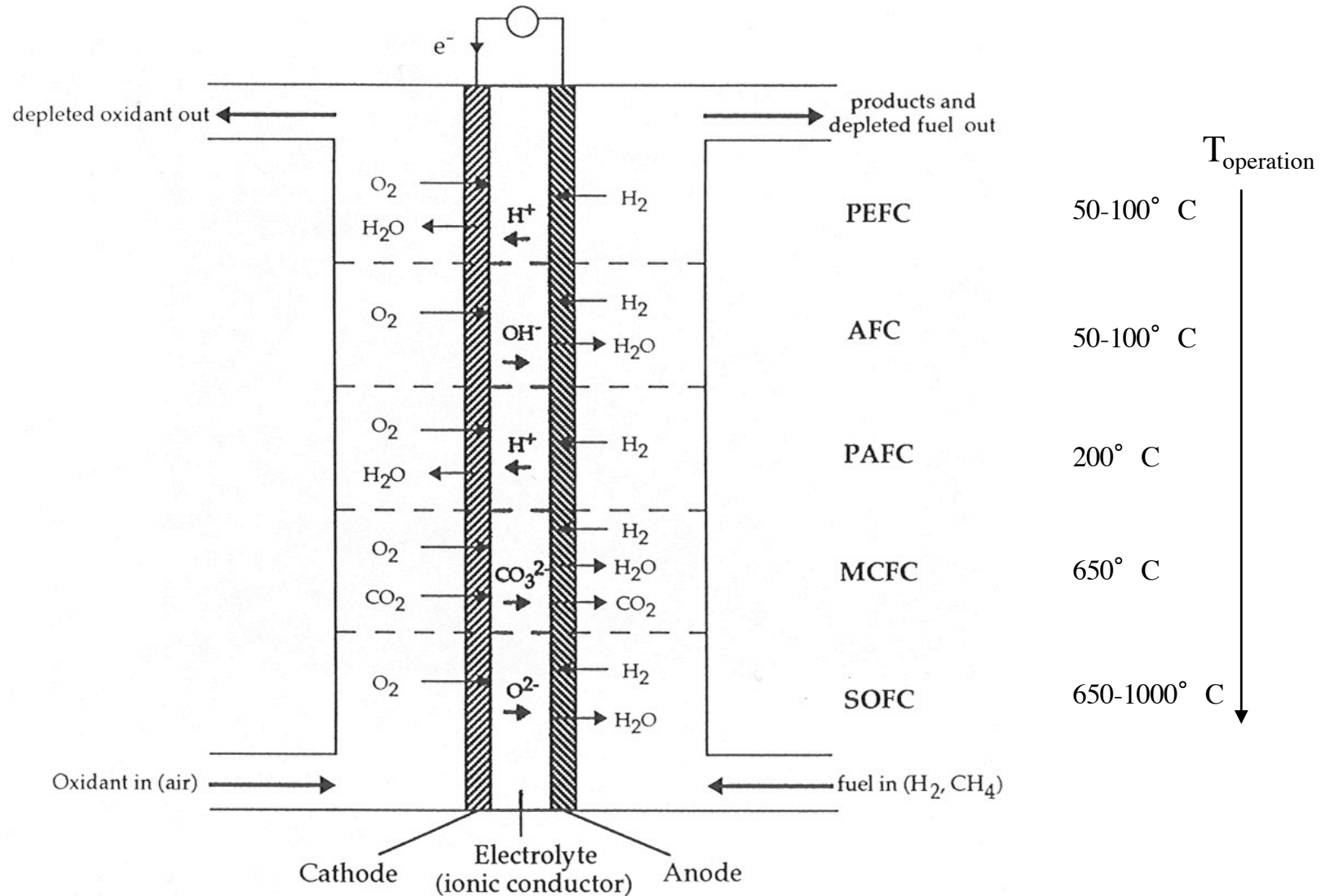

Fuels: distinction low vs. high T (H_2 vs C_xH_y)

Type	Electrolyte	Temperature	Fuel
AFC	Alcaline solution	20-100° C	H_2
PEFC DMFC ←	Polymere membrane	20-100° C	H_2 methanol
PAFC	liquid acide	20° C	H_2 (nat. gas)
MCFC	Molten salt	650° C	C_xH_y
SOFC	Solid ceramic	600-1000° C	C_xH_y

“direct” methanol

Materials in fuel cells: low vs high T (Pt vs Ni)

Type	Electrolyte	Cathode	Anode	Interconnect	Dimensions
AFC	KOH	Ag	Ni	conducting composite	flat, 50-500cm ²
PEFC	« Nafion » («sulfonated teflon »)	Pt on C	Pt(-Ru)	graphite	flat, 5-500 cm ²
PAFC	H ₃ PO ₄	Pt on C	Pt on C	graphite	flat, 1 m ²
MCFC	(Na,K,Li) ₂ -CO ₃	NiO or LiCoO ₂	Ni	inox	flat, 1 m ²
SOFC	90% ZrO ₂ + 10% Y ₂ O ₃	LaSrMnO ₃ LaSrFeO ₃ LaSrCoO ₃	Ni	Ferritic Cr or high Cr steel	flat, 10-400 cm ² tubes / (2 m long * 2 cm diam.)

Performance figures

Type	Cell size	Life (h)	W/cm ²	kW/L
PEFC	500 cm ²	80' 000	1	3
AFC	500 cm ²	20' 000	0.3	1
PAFC	1 m ²	100' 000	0.3	0.2
MCFC	1 m ²	60' 000	0.2	0.2
SOFC	400 cm ²	100' 000	0.5	0.5

SOFC stack assembly (movie)

APPLICATIONS OVERVIEW

Portable	0.1-100 W	electronics (competing with batteries)	DMFC, PEFC
Small cogen.	1 kW - 100 kW	«best» range (lower competition from μ T or diesel engines)	SOFC, PEFC
Transport	10 kW - 200 kW > 1 MW	vehicles, buses ships	PEFC, DMFC, AFC MCFC, SOFC
Medium cogen.	0.2 MW - 3 MW	offices, schools, hotels, hospitals, supermarkets; industry (chem./ steel/ foods)	PAFC, AFC MCFC SOFC

Power size

Application examples

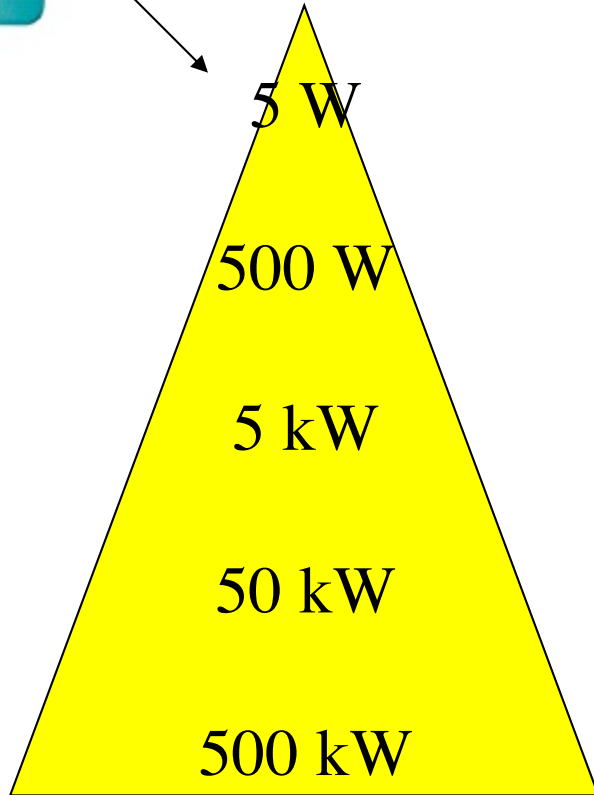

- Portable electronics
- Aggregates
- Houses
- Transport
- Urban cogeneration



(from F. Büchi, PSI)

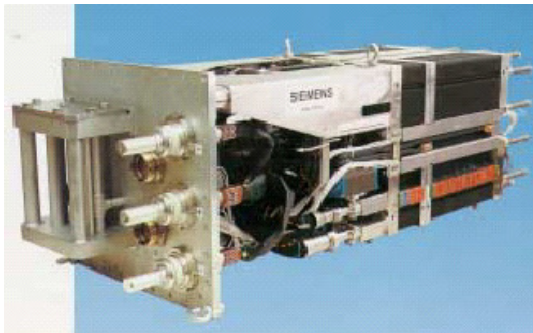

MXE-441

PEFC
800 kW_e

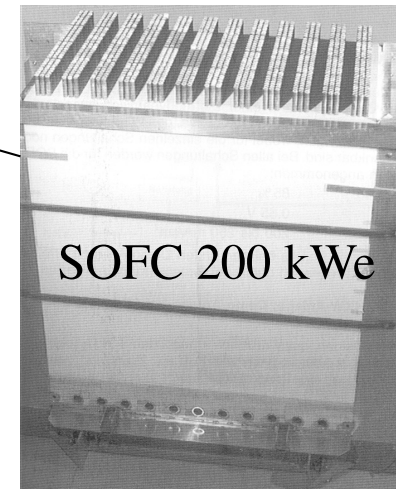

FUEL CELL SYSTEM

“conversion chain”

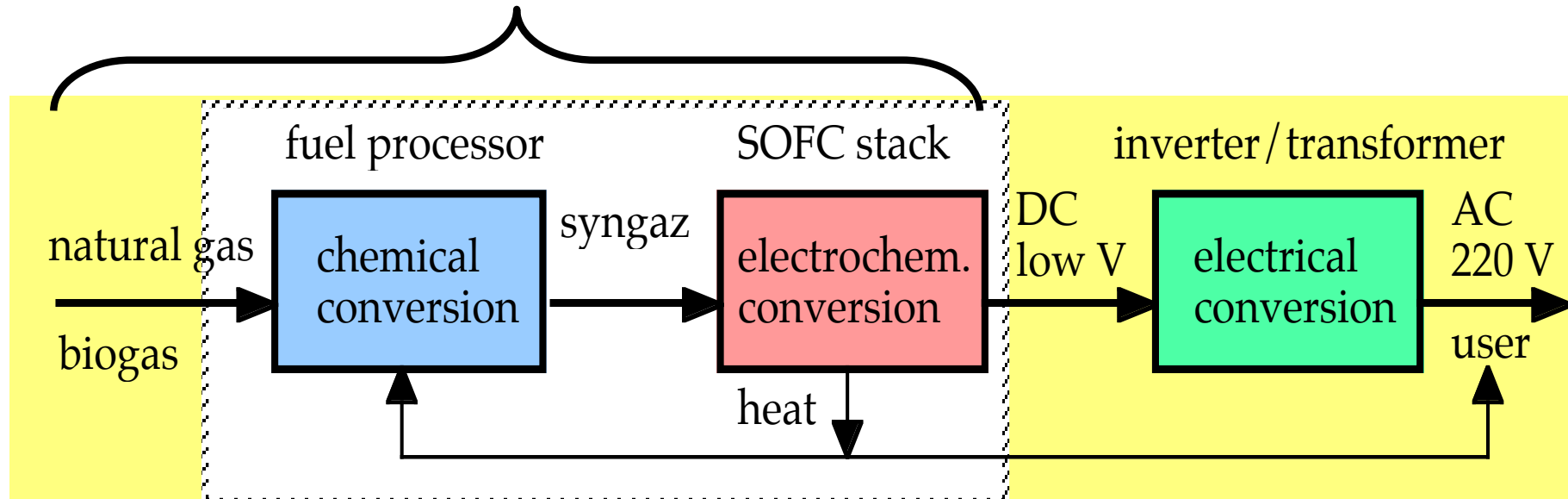

A system of 3 series converters :

1. FUEL PROCESSOR (fuel treatment)
2. FUEL CELL STACK
3. Electrical conditioning (DC/AC, DC/DC)

ADVANTAGES of Fuel Cells

- I. High **electrical efficiency**
 - a) for small power size (1 We - 1 MWe)
 - b) especially at *partial* load
- II. Low chemical and acoustical **emissions**
- III. **Cogeneration** of electricity & heat
- IV. **Modularity**
- V. Fuel **flexibility**
 - a) **fossils** (natural gas, diesel, coal gas,...)
 - b) **renewables** (biogas, biodiesel, woodgas, ethanol,...)

A fuel cell bypasses a mechanical cycle

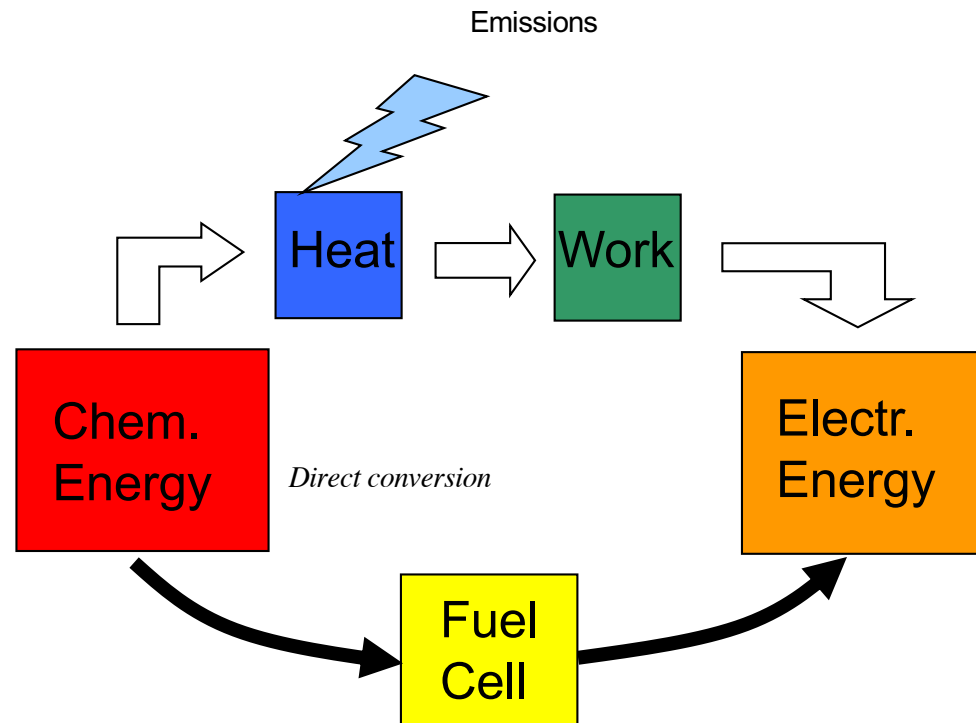

- rational use of (fossil) energy (**efficiency**)
- lowering **emissions** (integrated plants)
- electrical valorisation of **renewable fuels** (biogases, H₂, woodgas,..)

=> Motivation for fuel cell development

High electrical conversion at small power range

(based on natural gas, LHV)

(compiled by Quentin Jeangros, EPFL-CIME/Fuelmat)

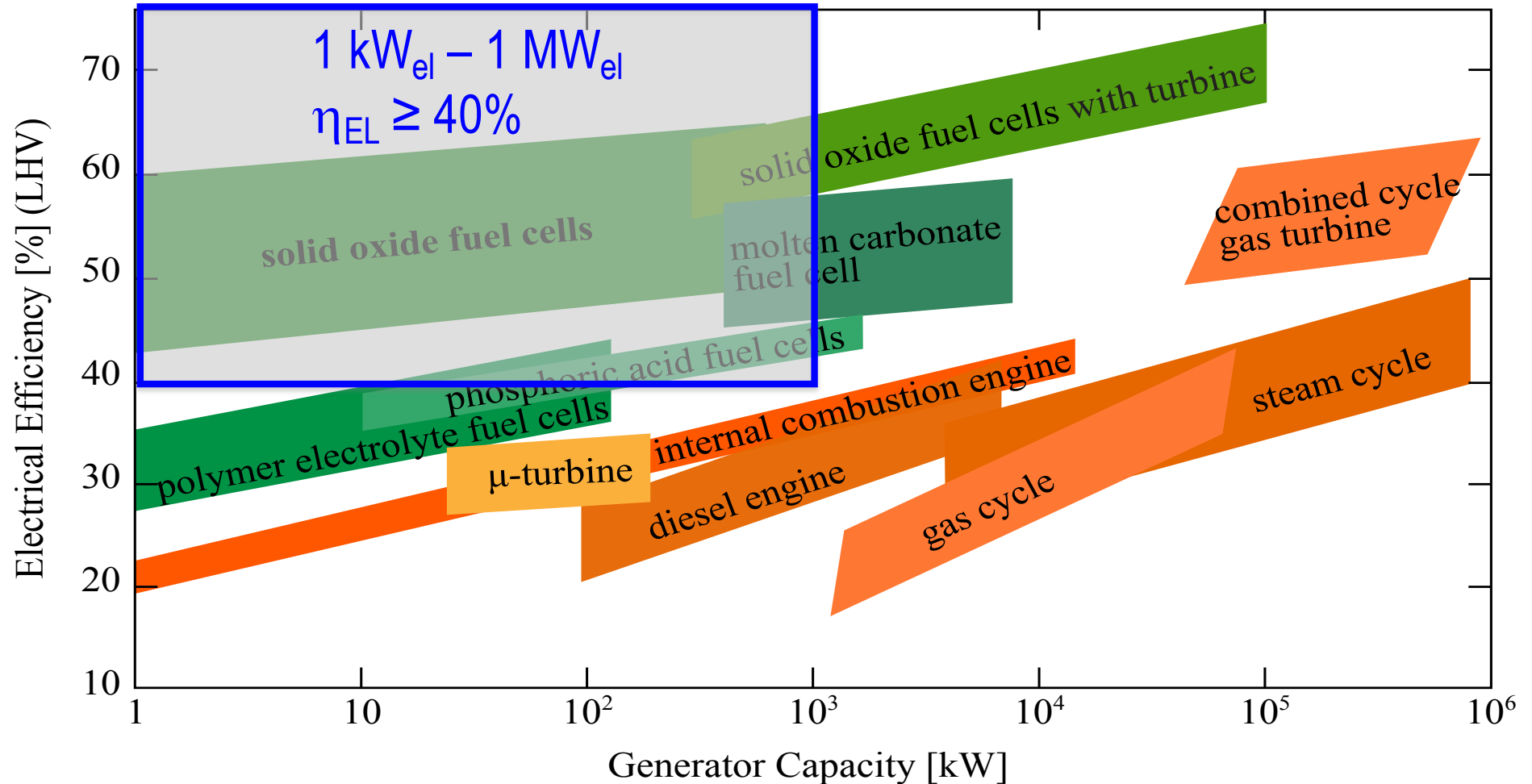

electrical efficiency as fct(power size)

Electrical efficiency: combustion vs electrochemistry

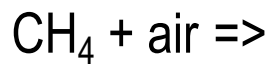

combustion



polluting emissions

ENGINES



http://www.sdeciepower.com/8.3L_Natural_Gas_Engine.htm

0.1 – 5 MW_{el}
η_{EL} 33-45%

TURBINES

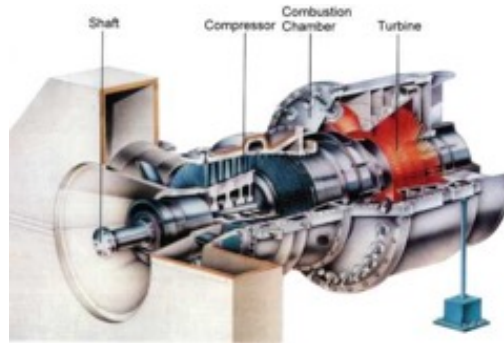

<http://www.wartsila.com/sv/kraftverk/learning-center/gas-turbine-for-power-generation>

5-100 MW_{el}
η_{EL} 27-40%

COMBINED CYCLES

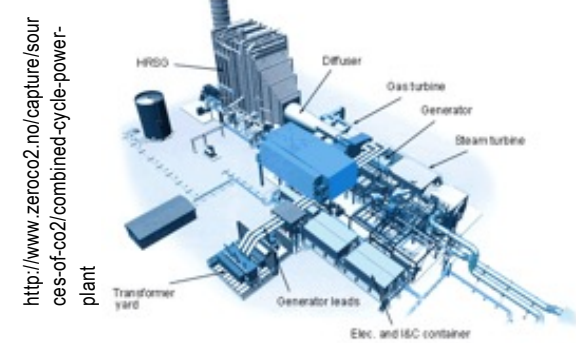

<http://www.zeroco2.no/capture/sources-of-co2/combined-cycle-power-plant>

50-500 MW_{el}
η_{EL} 50-60%

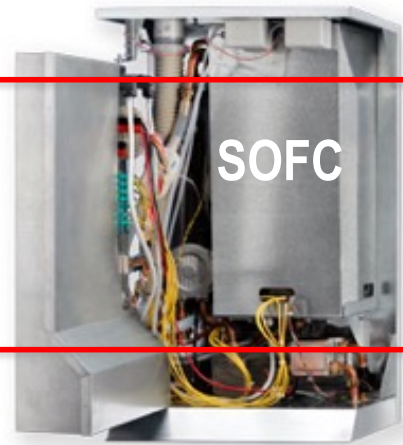
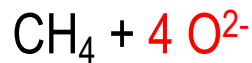

SOFC

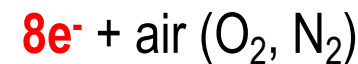

electrochemical
"combustion"

1 – 100 kW_{el}
η_{EL} 50-60%

no pollution

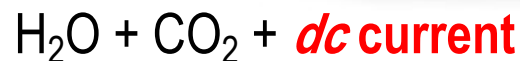
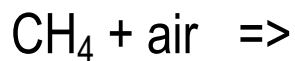

+ cogenerated useful heat

Part load: technology comparison

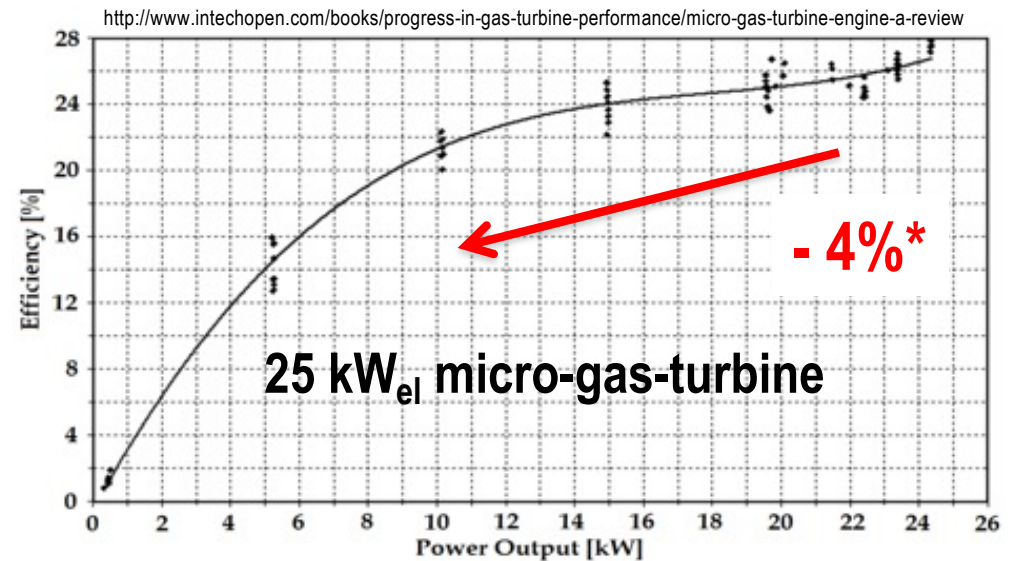
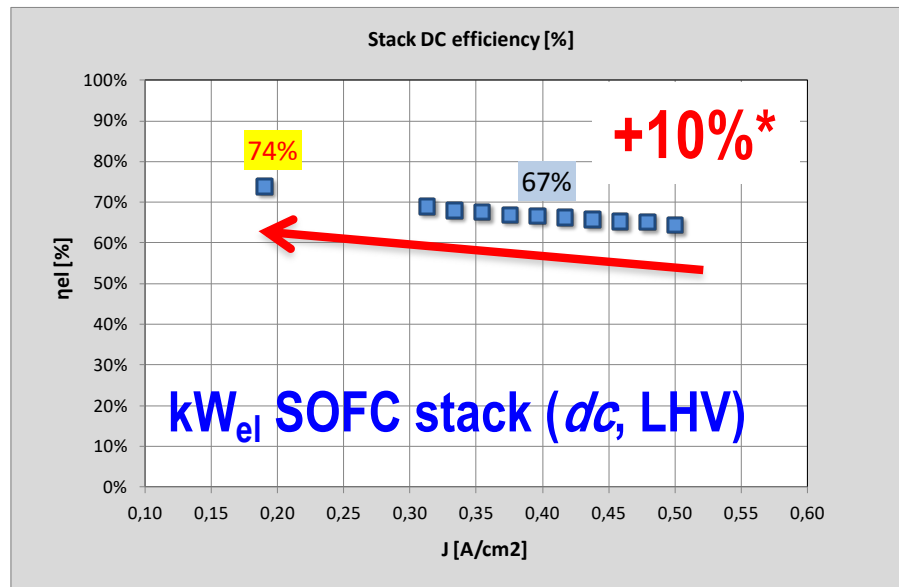
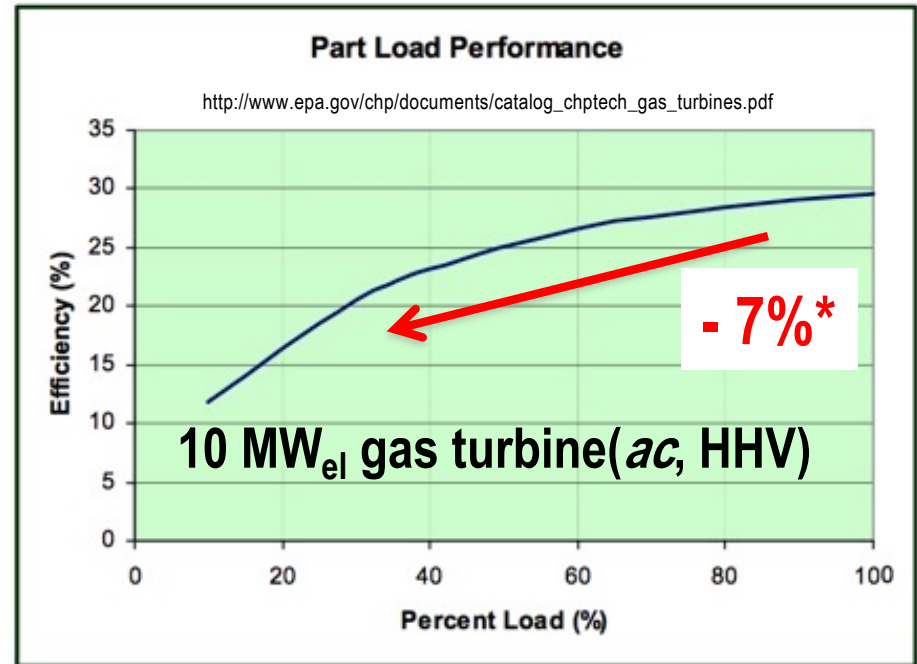
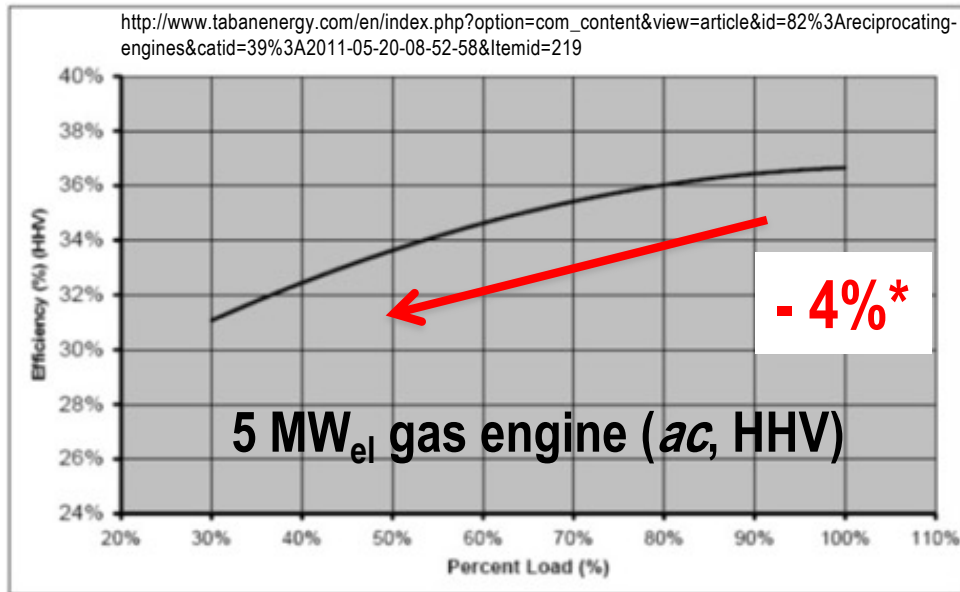

*from 100% to 40% power modulation

Characteristic i-V (current-voltage curve) of a fuel cell

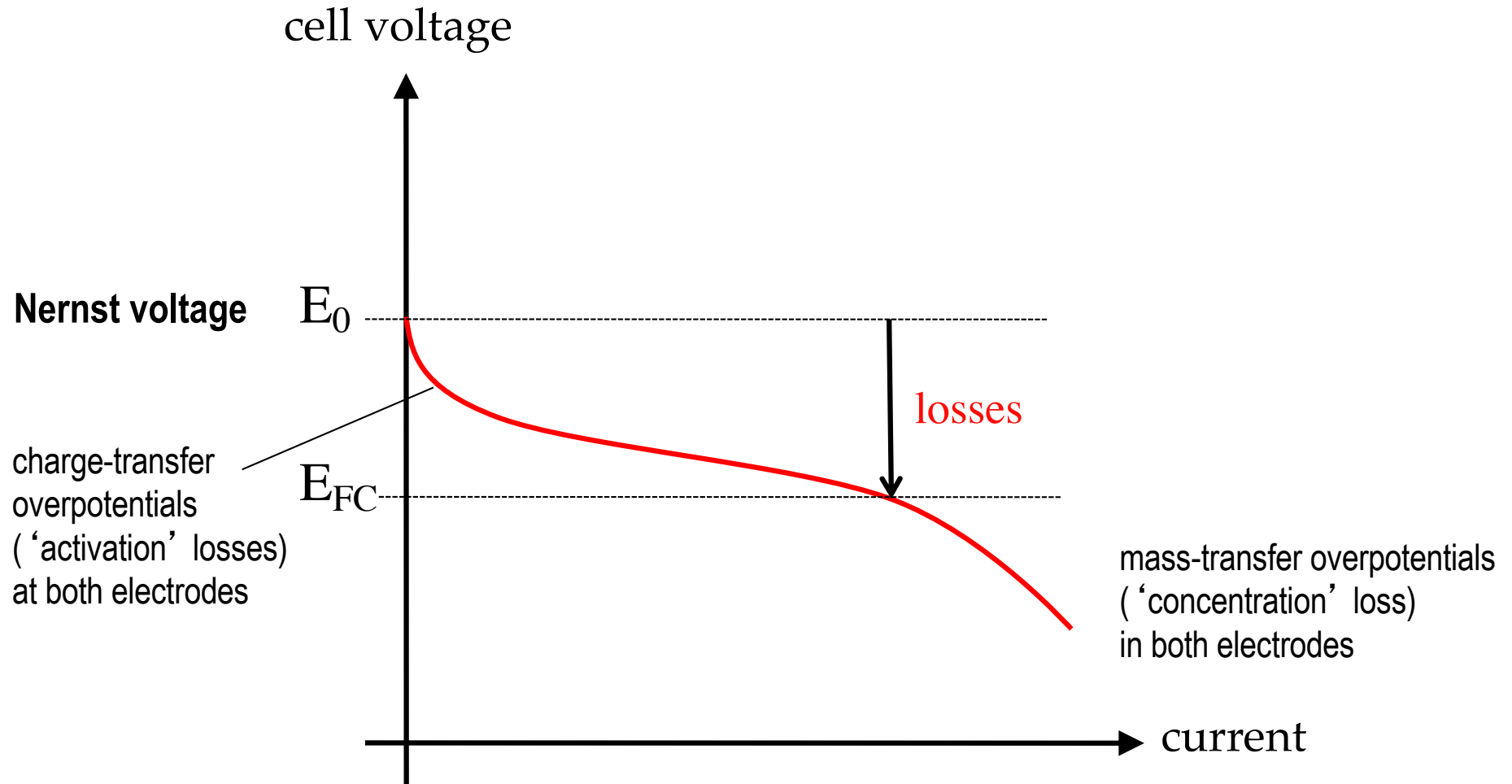

Nernst equilibrium voltage and thermodynamics

- in a fuel cell at equilibrium (start-up, no net external current), fed with H₂/O₂ (air), one observes the **creation of a voltage**, characteristic for the reaction H₂/O₂ : **1.229 V** (at 298K and 1 atm)
- the useful **work** (here: **electricity**) exploitable from this reaction H₂/O₂ is given by the **Gibbs free enthalpy** of the corresponding chemical reaction $\Delta G_r = \Delta H_r - T \Delta S_r$:
for H₂ + 0.5 O₂ -> H₂O
where $\Delta G_r^0(298K, 1 \text{ atm}) = -237' 150 \text{ J/mole}$

- the link between ΔG_r (J/mole) and the created voltage, E (or V, or U) is given by the amount of charge (in Coulomb, C) that can be exchanged across this voltage :

$$\Delta G_r = - nF.E$$

(with n = 2 exchanged electrons for H₂, F = Faraday constant = 96484 C / mol e⁻),
which leads to the value E⁰ = **1.229 V** (for H₂/O₂ at 1 atm, 298 K)

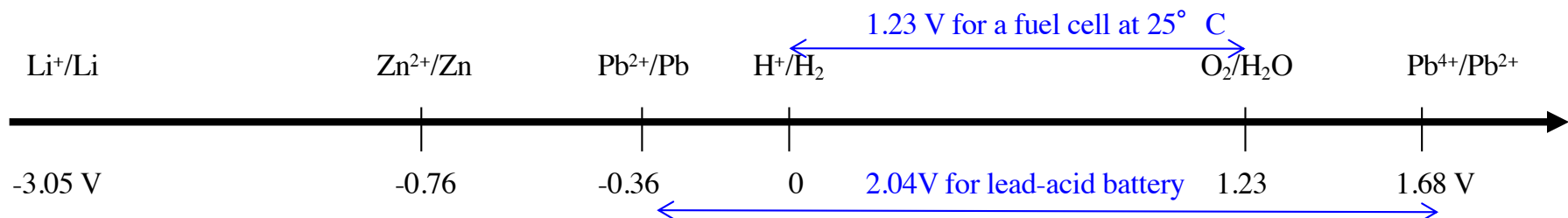

Energy balance in a fuel cell :

from fuel heating value INPUT (ΔH^0) to electrical power OUTPUT (η_{el})

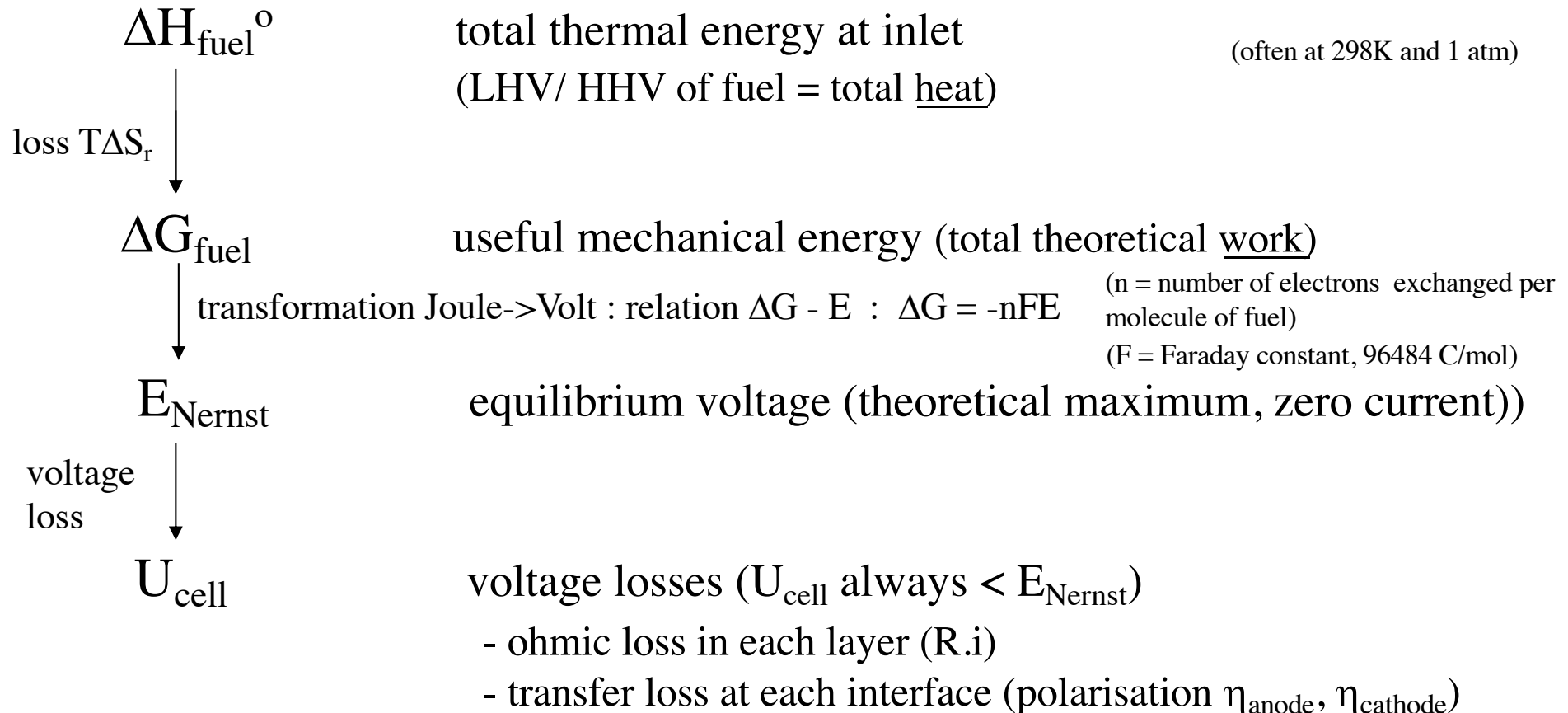

=> useful cell power

$$E_{pile} = E_{Nernst}(p, T) - (i \cdot R_{ohmique} + |\eta_{cathode}| + \eta_{anode})$$

$$P_{\acute{e}l} = E_{pile} \times i$$

Typical current density: 0.4 A/cm²

Typical useful voltage E_{pile} : 0.75 V

Series connection of cells ("stack") to increase E_{tot}

Example of PAFC :

- 240 cells in series (170 V)
- electrodes of 0.66 m x 0.66 m (1300 A)
- the stack module (1 m³) delivers 200 kW_{él} (and 200 kW heat)

with electrical efficiency : 40%

and global efficiency (cogeneration) >80%

Fuel cell electrical efficiency

$$\eta_{cell} = \frac{P[W]}{f[mol/s] \cdot \Delta H_{293K}[J/mol]} \quad \rightarrow \quad \eta_{cell} = \frac{I \cdot E_{cell}}{f[mol/s] \cdot \Delta H_{293K}[J/mol]} \frac{\Delta G(p,T)}{\Delta G(p,T)}$$

$$\eta_{cell} = \frac{I[A]}{f[mol/s] \cdot nF[C/mol]} \frac{E_{cell} [V]}{E_{Nernst} [V]} \frac{\Delta G(p,T)[J/mol]}{\Delta H_{293K}[J/mol]}$$

$$\eta_{cell} = \eta_I \cdot \eta_V \cdot \eta_{THDYN}$$

current efficiency,
"fuel utilisation"

voltage efficiency

thermodynamic
efficiency

Efficiency H₂ vs. CH₄, with air

	H ₂ , 80C (PEFC)	H ₂ , 800C (SOFC)	CH ₄ , 800C (SOFC)
Fuel utilisation	1	0.85	0.8
* Voltage efficiency	0.65	0.8	0.8
* Thermodynamic efficiency (LHV)	0.93	0.78	1
= Electrical efficiency (LHV)	0.6	0.53	0.64

- these values have been achieved in real systems.
- there is usually co-generation of useful heat, for total efficiencies of $\approx 90\%$.
- CH₄ has the intrinsic benefit of presenting **no entropy loss**.
- H₂ carries an additional intrinsic loss as it has to be synthesized first.

➔ **Methane-FC (natural gas, biogas) are (in principle) more efficient than H₂-FC.**

World fuel cell market growth: by type, MW's, and numbers

53'600 PEFC / 1030 MWe
25'000 SOFC / 150 MWe

Micro-CHP (53'000):
47'000 Japan, 5'000 Germany
Forklifts (10'000)
Portable FC (4'000)

Megawatts by fuel cell type 2016 - 2020

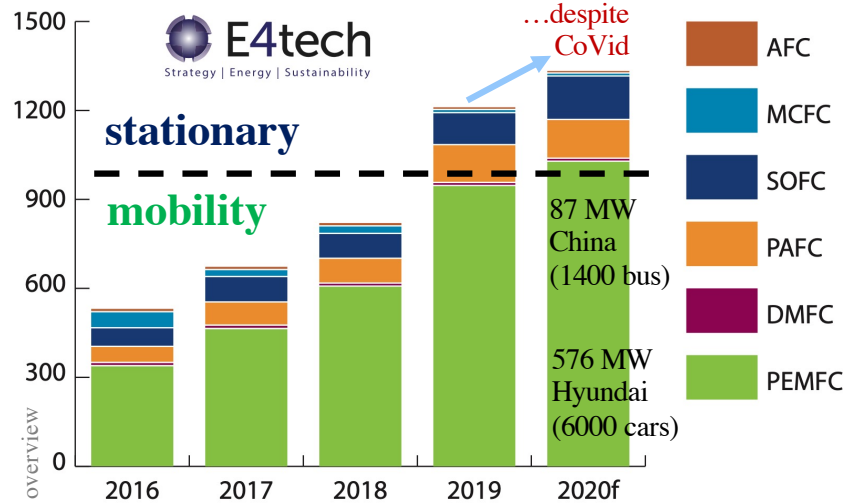

Total installed power now > 4.5 GWe

Shipments by fuel cell type 2016 - 2020 (1,000 units)

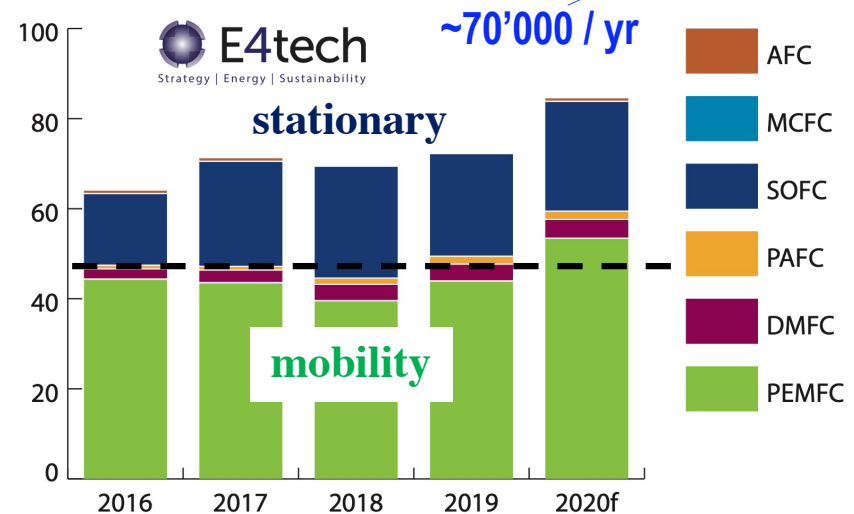

Total cumulated now > 550'000 systems

360'000 Micro-CHP in Japan
self-sustaining market (no more subsidy)
12 yrs life

ABB EBC / FC overview

Jan Van herle / gem.epfl.ch

Facts & figures update 2020

<https://www.e4tech.com/resources/246-e4tech-produced-its-annual-fuel-cell-industry-review-now-in-its-7th-year.php>

- In 2020, 82500 FC units were shipped, up by 100 MW to a total of 1'300 MW
 - >50000 fuel cell micro-CHP units went to Japan and Germany
 - Hyundai shifted 8500 NEXO cars
 - Materials handling units (forklifts) was up too, with Plug Power shipments of 10'000 units
- Asia remains in the lead because of **policy**
- Strong drive in **automotive** industry:
 - New Mirai (Toyota) in 2020: 20% smaller and 50% lighter FC stack for higher power (128 kW); 30% higher range
 - 2020 shows a record number in new hydrogen refuelling stations (HRS)
 - California adding 110 HRS until 2025 to 60 existing HRS
 - Japan has 133 (target 320 by 2025); Korea 43; 100 in D, 80 in F/UK/N/other; China 37
 - First 10 Xcient Hyundai buses are delivered to Switzerland; 190kWe, 400km range 1 charge; the EU targets 5000 trucks by 2025
 - Weichai China has 20'000 unit per annum PEM factory
 - 115 FC buses circulate in EU; hundreds are on order; China is clearly in the lead for buses (3600 now)
 - 50'000 vehicles are intended to be on Chinese roads by 2025
 - Hyundai targets 200'000 cars by 2025 in Korea, Toyota 200'000 cars by 2025 in Japan
 - Daimler and Volvo set up a fuel cell truck JV (on liq. H₂)
 - Marine activities: Ballard, Nedstack, Powercell and Proton Power have all taken maritime orders, Hyundai has its own ship company.
 - The first FC excavator has been developed
- Largest installed **stationary** powers:
 - 59MW MoltenCarbonateFC power in Korea
 - 50 MW PhosphoricAcidFC power in Korea, H₂-fueled (from by-product H₂)
 - 30MW SOFC (Bloom)
 - Korea plans a 400MW/yr FC power deployment

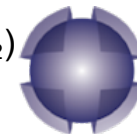

E4tech
an ERM Group company

Summary

- great progress in Fuel Cells since 2 decades
 - H₂-cars and buses (50 – 200 kW_e PEFC)
 - residential micro-CHP (1-2 kW_e SOFC, natural gas)
 - efficient clean cogeneration plants (MW_e-sized SOFC + MCFC, incl. biogas)
- big effort in R & D continues
- competition (engines, batteries,...) progresses a lot too!
- issue of the H₂-storage & distribution, H₂-society
- electrolysers (reverse fuel cells) are coming up strongly (combined with renewable electricity increase (PV, wind))