

PAUL SCHERRER INSTITUT

PSI

EPFL



Steven Van Petegem – Material Science at Large Scale Facilities

Interaction of X-rays/Neutrons with Matter

Master Course 2025

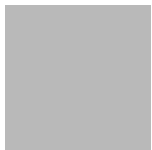

Particle - wave duality

Compton scattering: light as particles

Photoelectric effect: light as particles

Young's slit experiment: light as waves

SANS: Neutrons as waves

Dipole radiation: light as waves, electrons as particles

Particle-wave duality

Single model (i.e., wave or particle) inadequate to explain all observations of microscopic systems
 Neutron beam also has a wave character
 X-rays: electromagnetic wave (as visible light is), particle of light = photon

Phenomenon	Can be explained in terms of waves.	Can be explained in terms of particles.
Reflection		
Refraction		
Interference		
Diffraction		
Polarization		
Photoelectric effect		

<http://hyperphysics.phy-astr.gsu.edu/hbase/mod1.html>

Speed, wavelengths, and frequencies

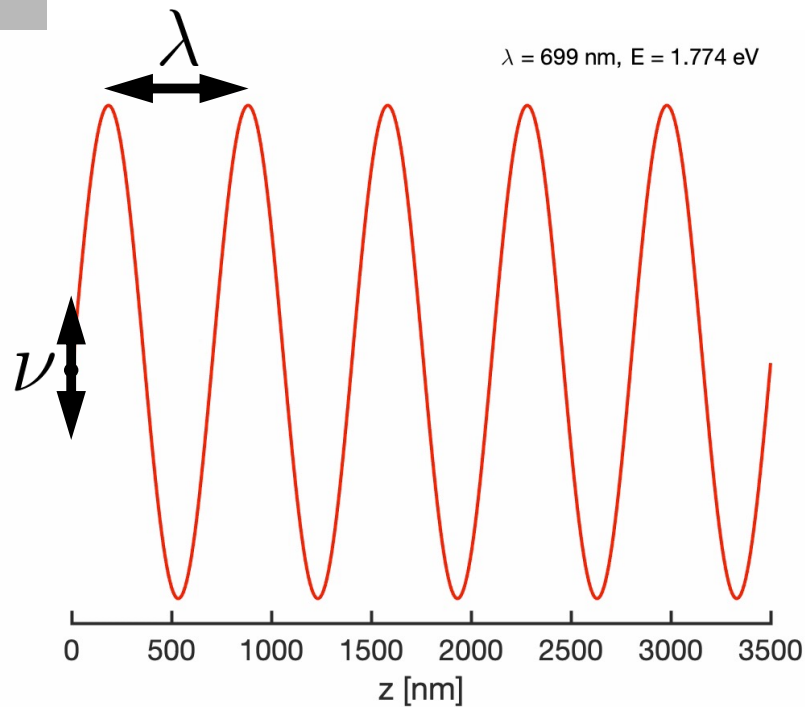

Red (700 nm) to blue (400 nm)
visible light

$$c = \nu \lambda$$

Velocity of light c = constant in vacuum

$$c = 2.9979 \times 10^8 \text{ m s}^{-1}$$

As wavelength λ decreases, frequency ν increases

Speed, wavelengths, frequencies and energy

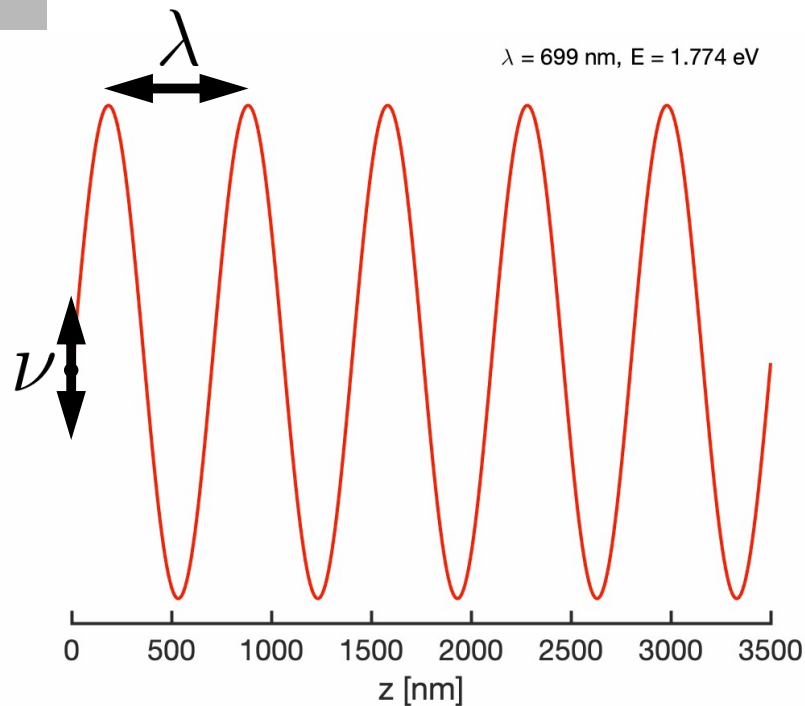

Red (700 nm) to blue (400 nm)
visible light

Philip Willmott: Synchrotron and X-ray Free Electron Laser

$$E = h\nu = hc/\lambda$$

h = Planck's constant

$h = 6.626 \times 10^{-34} \text{ J s}$

$\hbar = h/2\pi = 1.055 \times 10^{-34} \text{ J s}$

Visible light

$E = 1.774 \text{ eV @ } 700 \text{ nm}$

$= 3.100 \text{ eV @ } 400 \text{ nm}$

Electronvolt = eV

Energy of an electron after being accelerated from rest in a potential of 1 V

$1 \text{ eV} = 1.6022 \times 10^{-19} \text{ J}$

The electromagnetic spectrum

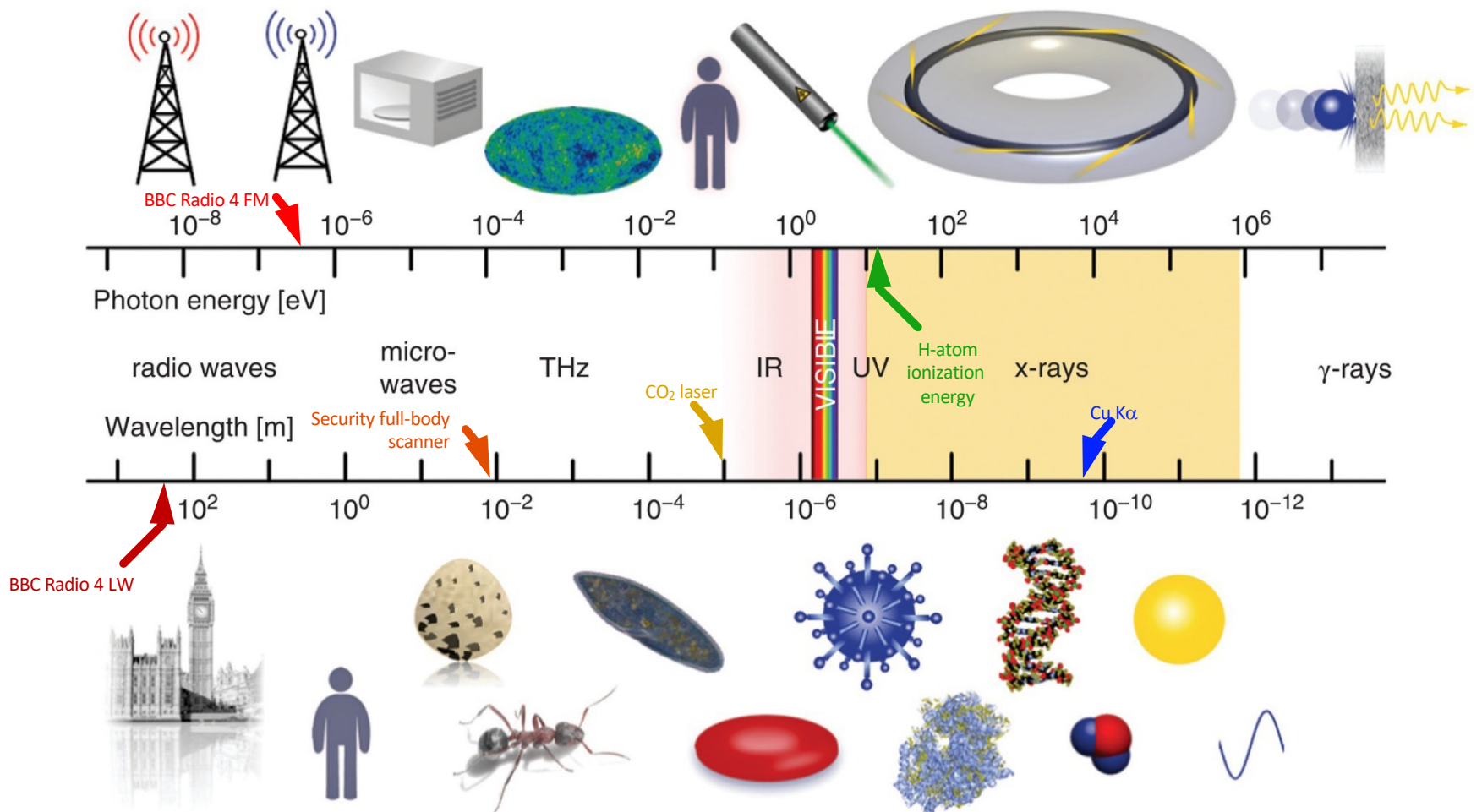

Philip Willmott: Synchrotron and X-ray Free Electron Laser

Electronvolts and the atomic world

Chemical reactions

Imagine a chemical reaction resulting in a 1 eV difference in energy per involved molecule

$$1 \text{ eV/molecule} \times 6.022 \times 10^{23} \text{ molecules/mole} \\ = 1.6022 \times 10^{-19} \times 6.022 \times 10^{23} = 96.5 \text{ kJ/mol}$$

100 kJ/mol IS TYPICAL FOR REACTION ENTHALPIES

Chemical bonds

Graphite interplanar van-der-Waals bond = 0.05 eV

Diamond C-C bond = 3.5 eV

Ionization energy of H-atom = 13.6 eV

Thermal energy = $3k_B T/2 = 0.04 \text{ eV @ RT}$

Core-electron binding energies

0th approximation: 1s B.E. = $13.6 \times Z^2 \text{ eV}$

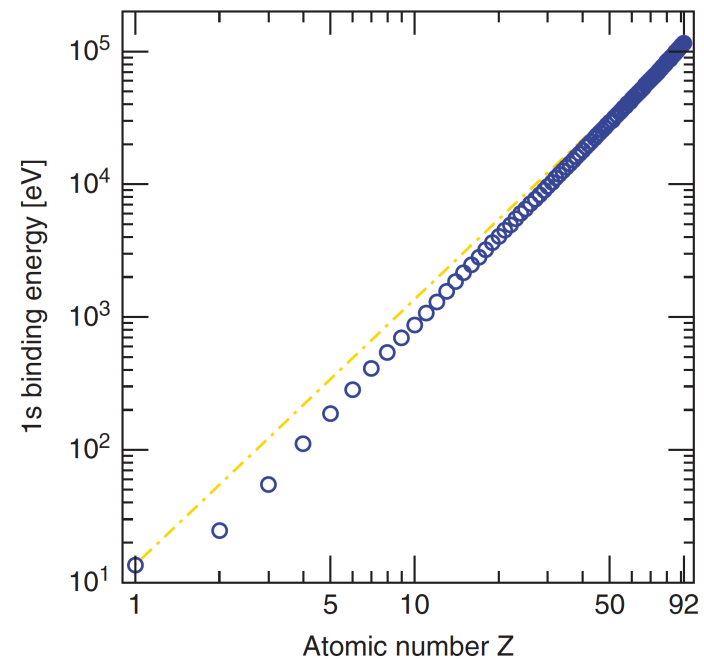

Electromagnetic wave

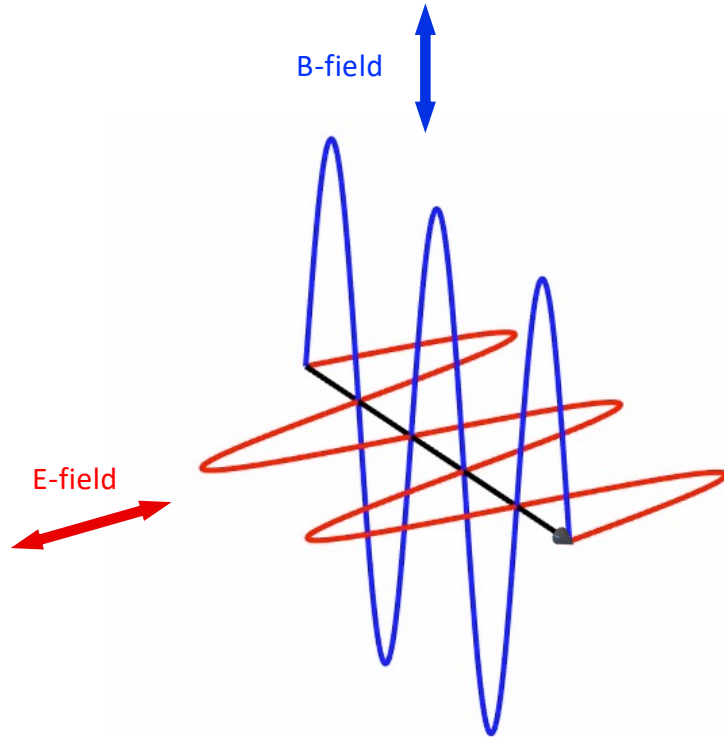

Transverse E- and B-fields \Rightarrow displacements perpendicular to direction of propagation

E- and B-fields: amplitudes E_0 and B_0

Oscillating at same frequency and phase

X-rays: $\nu \sim 10^{18}$ Hz

We can only **record the intensity** $\propto |\text{amplitude}|^2$

Phase information is lost!

Neutrons – particles and wave

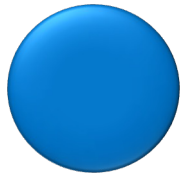

Neutron

$$m = 1.6749 \cdot 10^{-27} \text{ kg}$$

- mass is about 1840 times that of an electron
- has zero electric charge
- has a magnetic moment

$$E = \frac{mv^2}{2} = \frac{h^2}{2m} \cdot \frac{1}{\lambda^2}$$

Neutrons	Energy range	Wavelength [Å]	Velocity [m/s]
ultra cold	≤ 300 neV	≥ 500	≤ 8
very cold	300 neV - 0.12 meV	52.2 – 26.1	7.5 – 152
cold	0.12 meV - 12 meV	26.1 – 2.6	152 – 1515
thermal	12 meV - 100 meV	2.6 - 0.9	1515 - 4374
epithermal	100 meV - 1eV	0.9 - 0.28	4374 - 13.8 10 ³
intermediate	1eV - 0.8MeV		
fast	> 0.8MeV		

Coherence

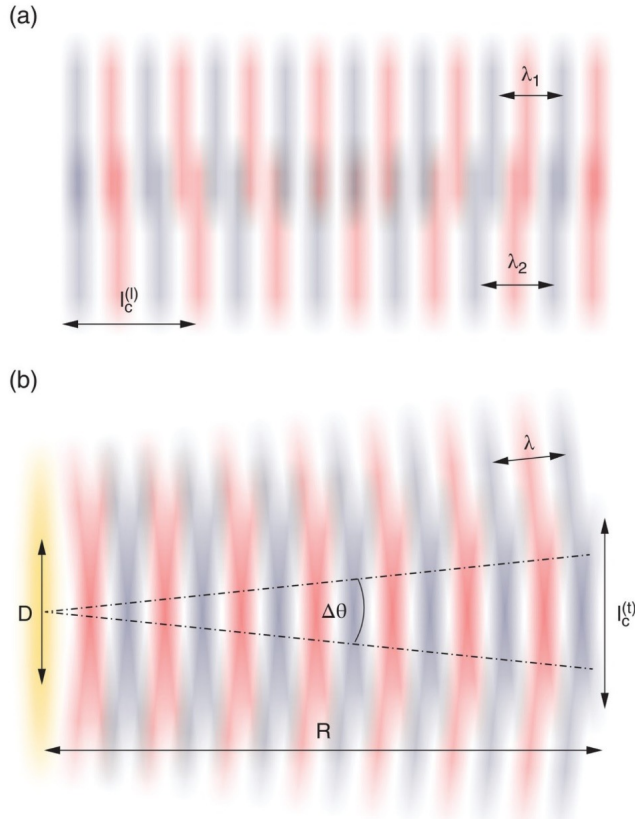

longitudinal (temporal) coherence length
determined by monochromacy of the source

$$l_c^{(l)} = \frac{\lambda^2}{2\Delta\lambda}$$

transverse (spatial) coherence length
depends on the beam divergence and source size

$$l_c^{(t)} = \lambda/2\Delta\theta = \lambda R/2D$$

Willmott, P. (2019). Scattering Techniques. An Introduction to Synchrotron Radiation, John Wiley & Sons, Ltd: 133-221.

Interaction types X-rays vs. Neutrons

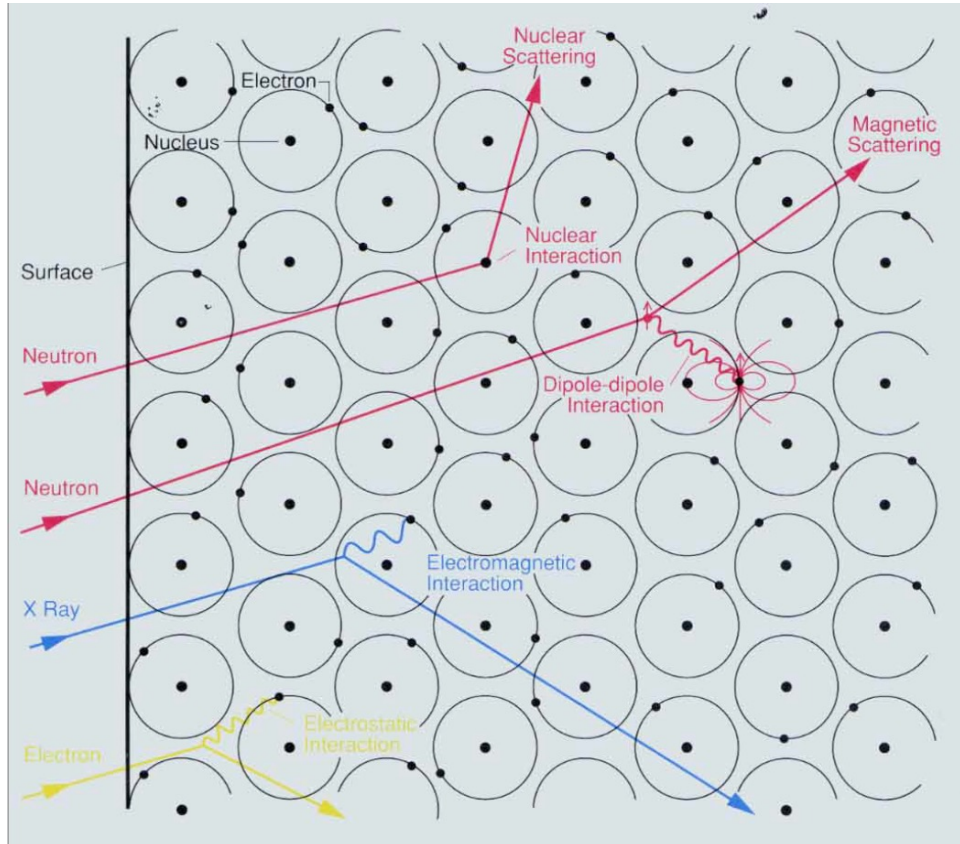

X-rays and electron-beam interact with electrons in the materials, neutrons with the atomic nuclei

electron beam: electrostatic, strong interaction, very low penetration depth

X-ray: electromagnetic, rather strong, intermediate penetration depth

Neutrons: short-range strong nuclear interaction, large penetration depth, for unpaired electrons: magnetic scattering

<https://www.ncnr.nist.gov/summerschool/ss16/pdf/NeutronScatteringPrimer.pdf>

Strength of Interaction: Cross-sections



Radius r_1

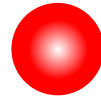

Radius r_2

(1) Hard spheres

Strength of Interaction: Cross-sections

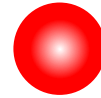

Strength of Interaction: Cross-sections

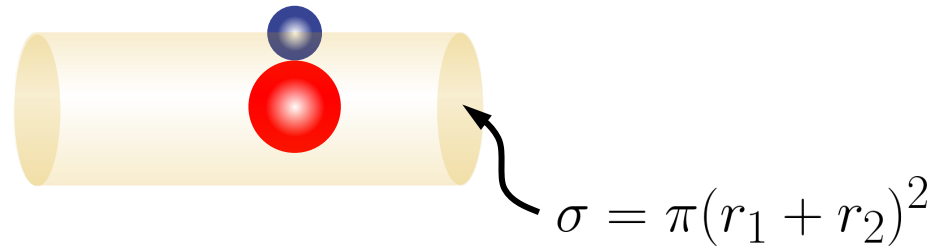

Strength of Interaction: Cross-sections



photon

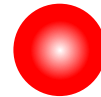

atom

Action at a distance (e.g. electromagnetic radiation interacting with atoms/matter)

Cross section for different elements

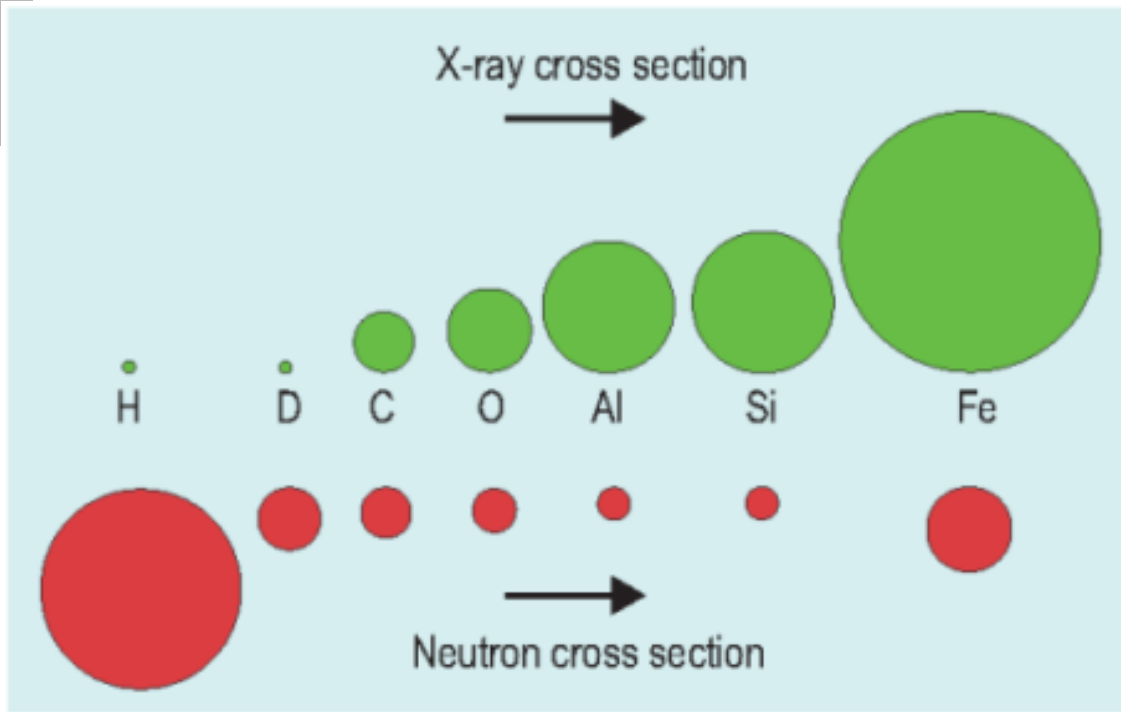

Scattering length of atoms are documented in table which can be found e.g. on the internet: <http://www.ncnr.nist.gov/resources/n-lengths/>

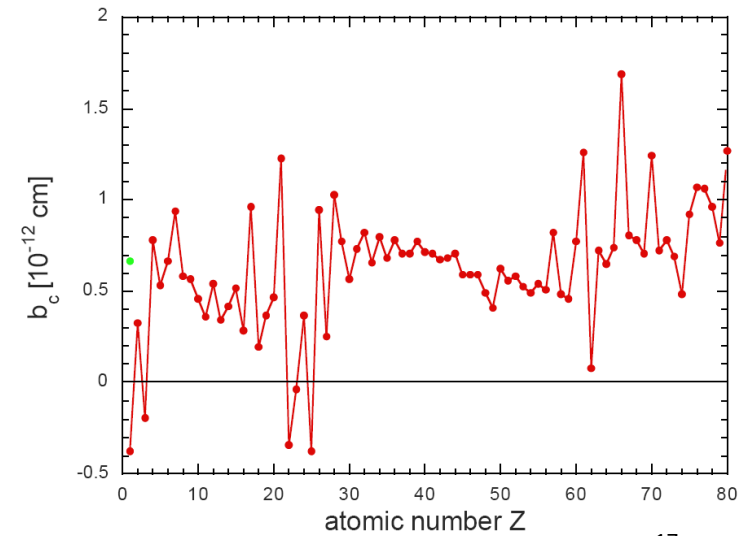
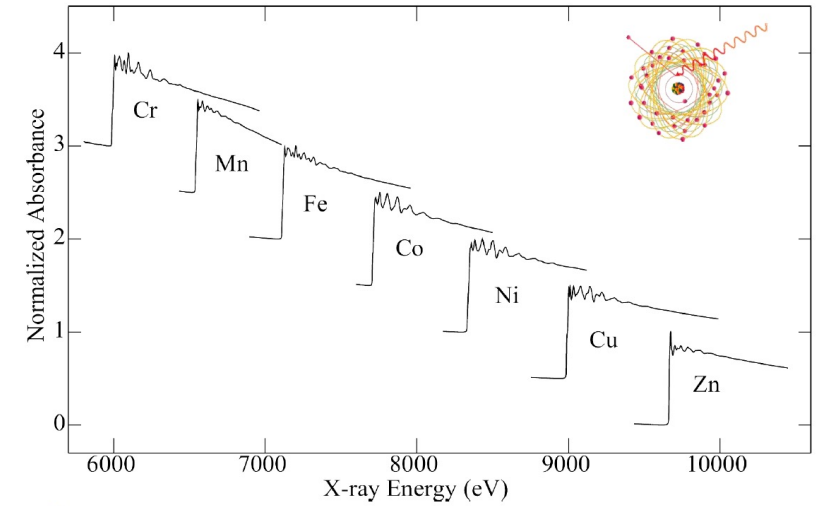

Neutrons: metals are transparent, water absorbs



Interaction of X-rays with matter

interaction with electrons

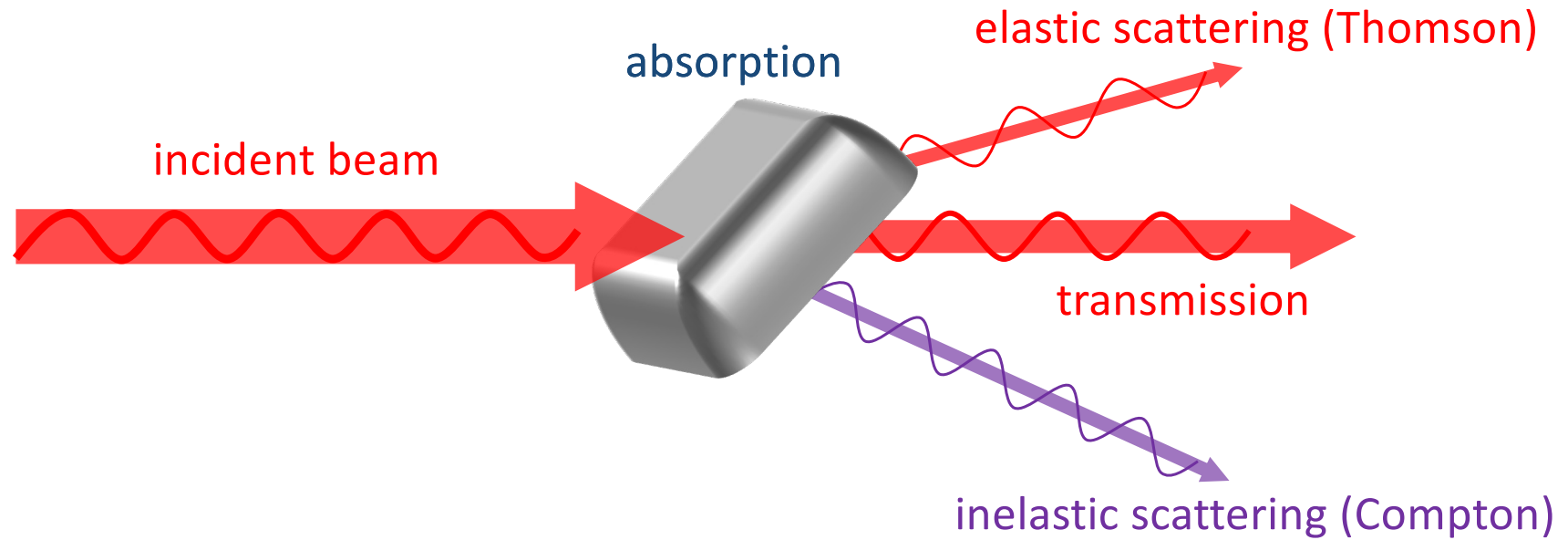

Interaction strengths of x-rays with matter

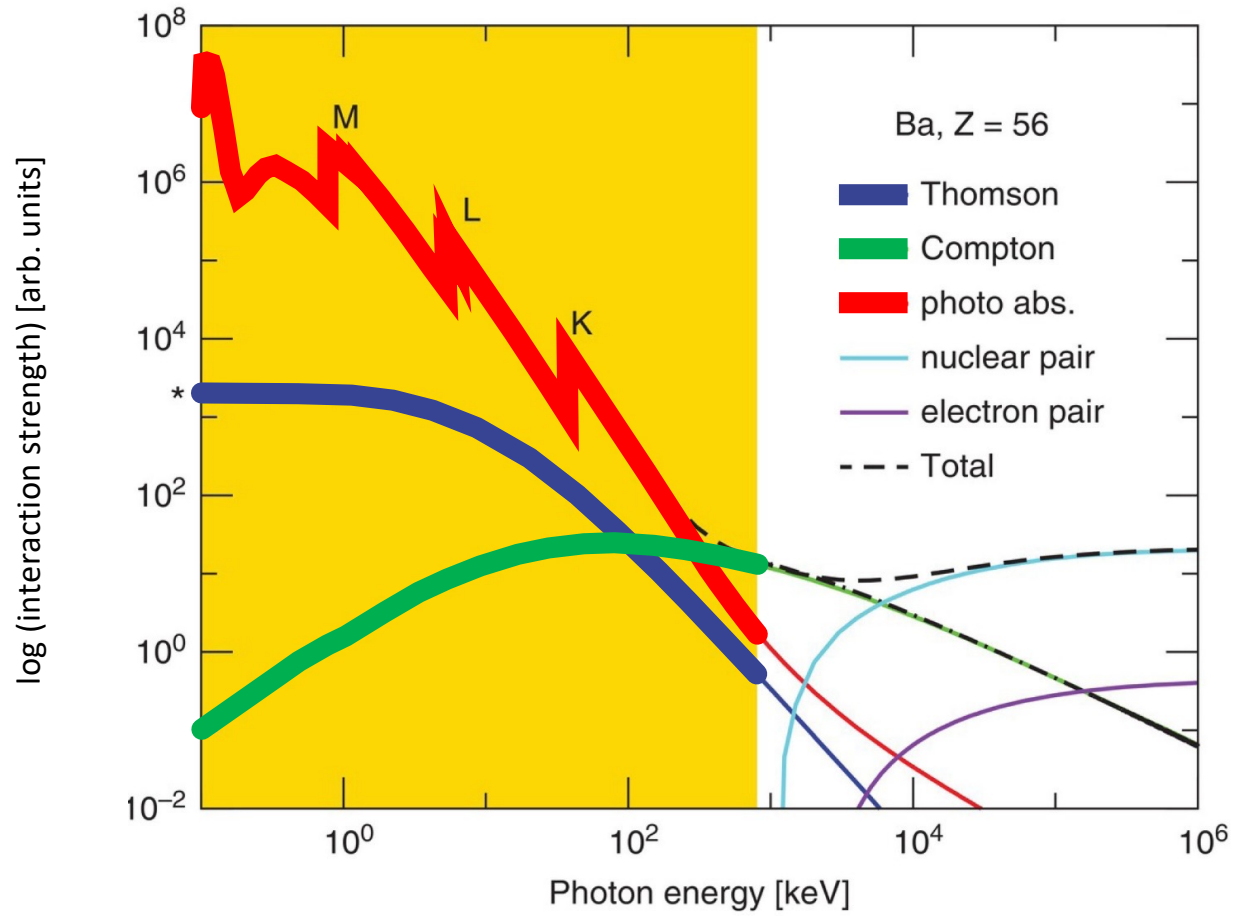

Philip Willmott: Synchrotron and X-ray Free Electron Laser

Interaction of X-ray with matter

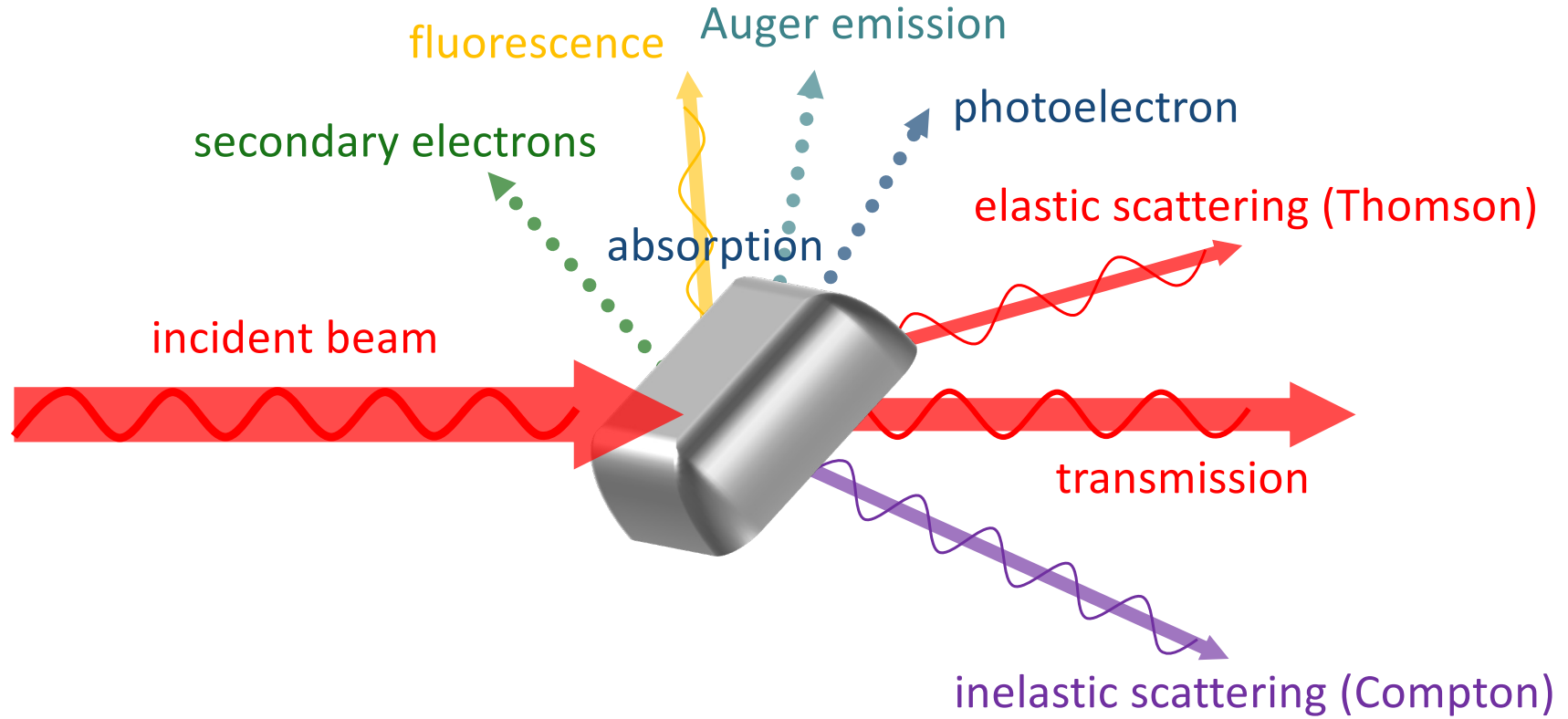

Interaction of neutrons with matter

interaction with nuclei (& magnetic moment)

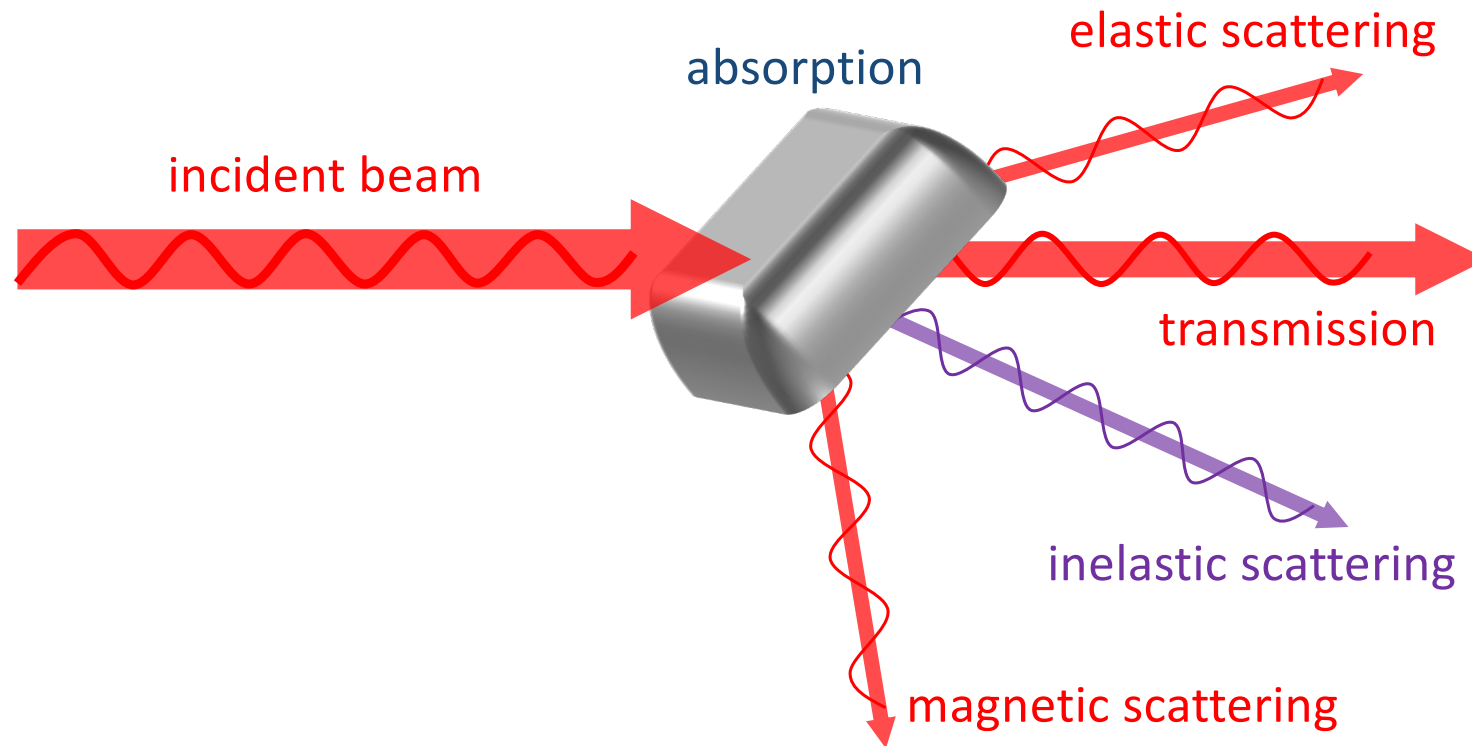

Interaction of neutrons with matter

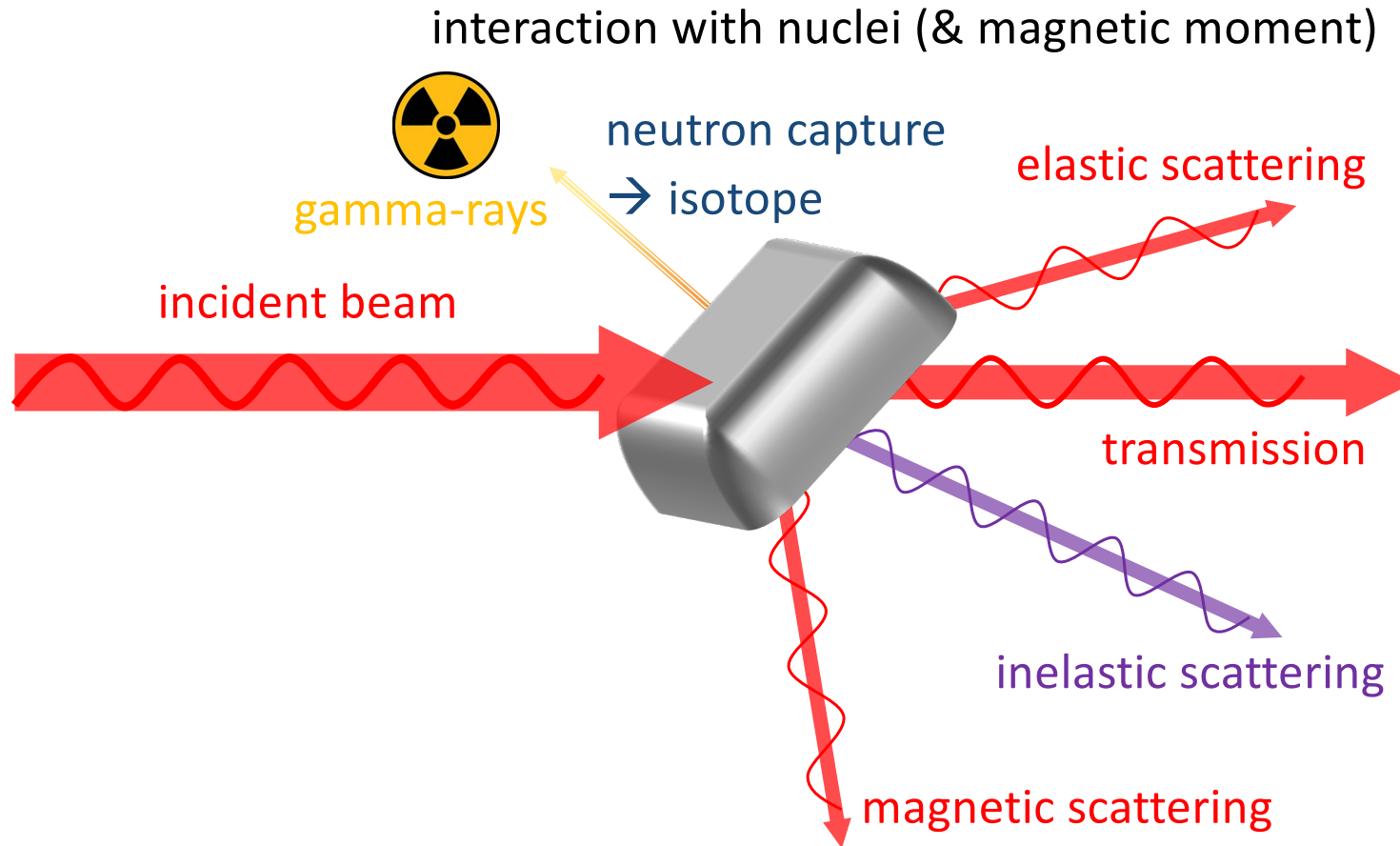

Interaction of X-rays and neutrons with matter

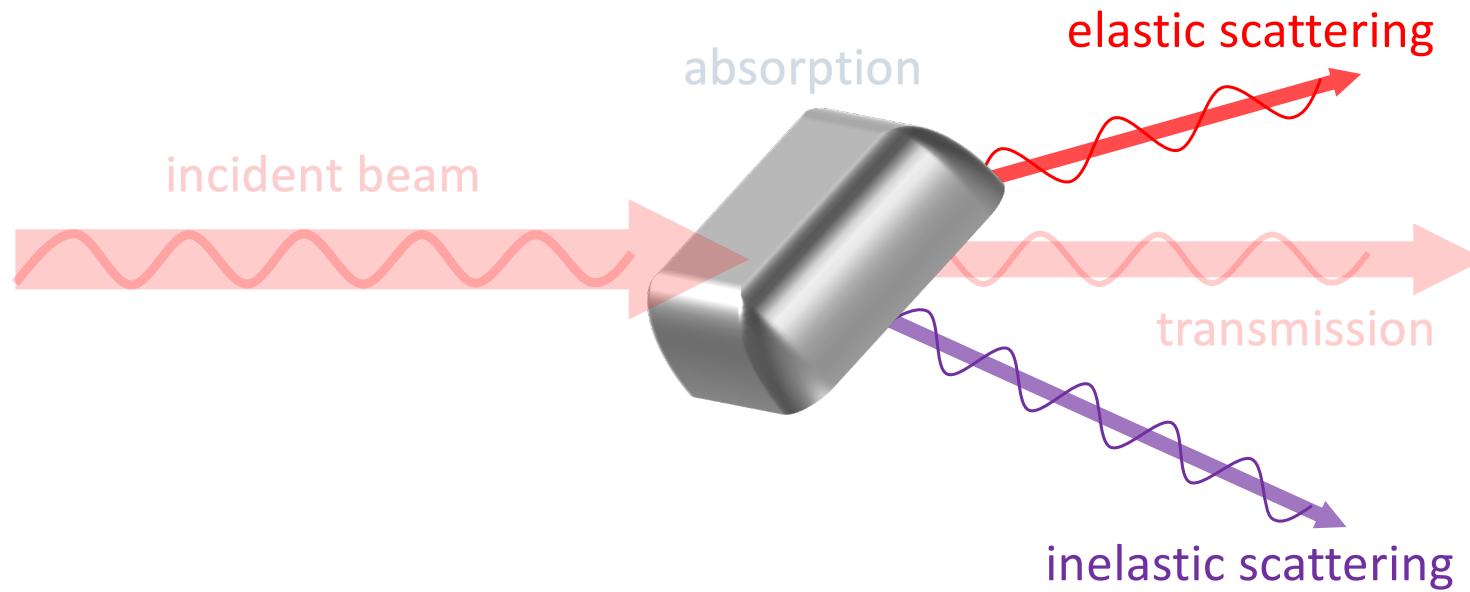

Scattering and Q-vector

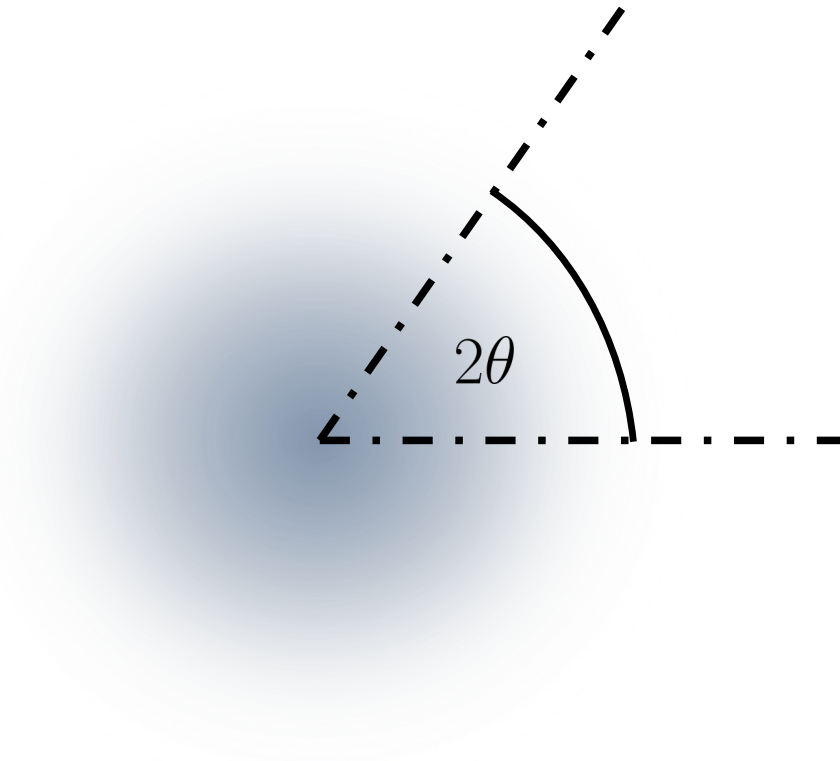

Scattering and Q-vector

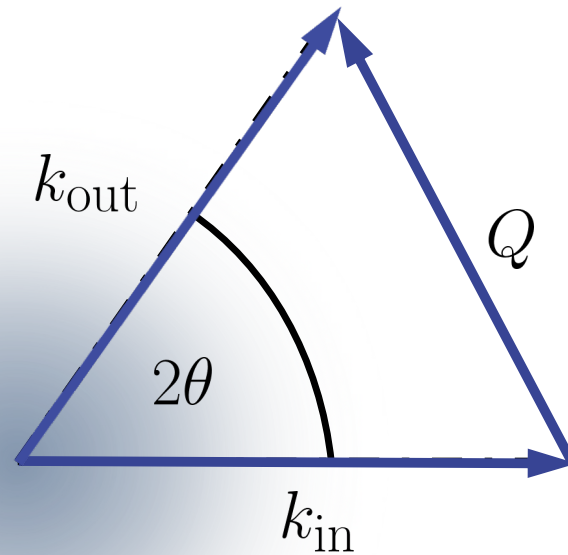

wave vector $k = 2\pi/\lambda$

scattering vector $Q = k_{in} - k_{out}$

Elastic scattering vs. inelastic scattering

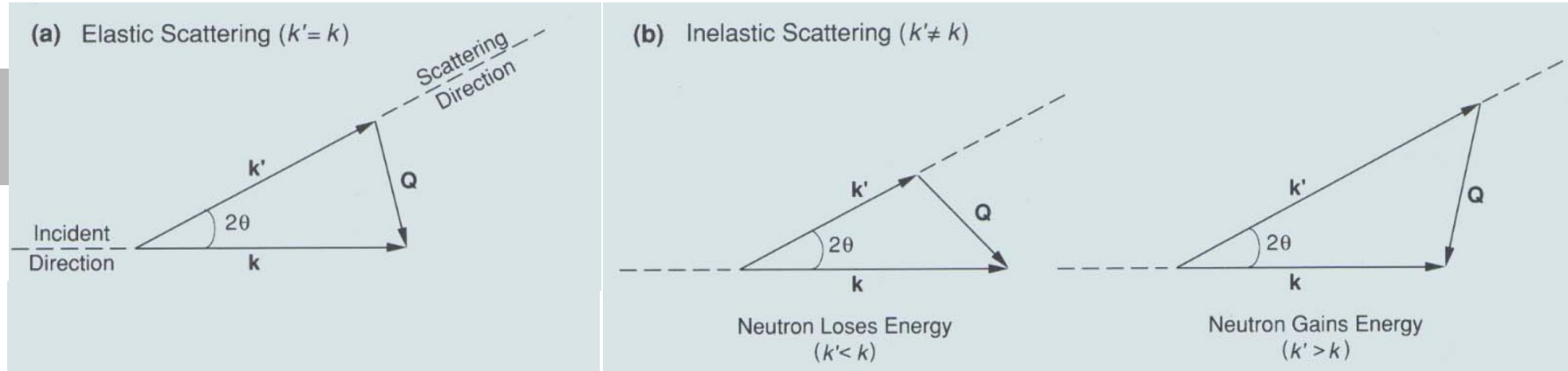

elastic scattering: scattering with no change in the energy of the incident neutron/photon, the direction of the vector changes but not its magnitude $|k_{in}| = |k_{out}|$

inelastic scattering: scattering in which exchange of energy and momentum between the incident neutron/photon and the sample causes both the direction and the magnitude of the wave vector to change $|k_{in}| \neq |k_{out}|$

Inelastic X-ray scattering: Compton scattering

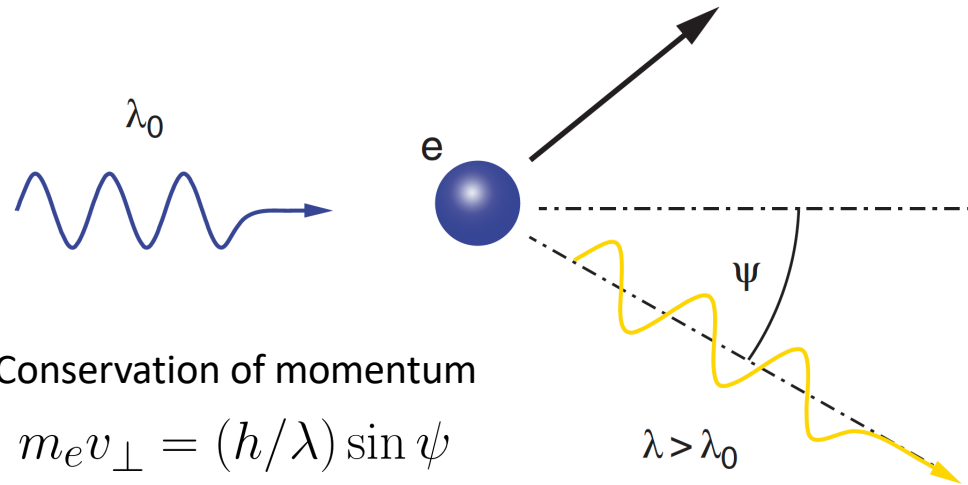

Conservation of energy

$$hc/\lambda_0 + m_e c^2 = hc/\lambda + E_e$$

Conservation of momentum

$$m_e v_{\perp} = (h/\lambda) \sin \psi$$

$$h/\lambda_0 = m_e v_{\parallel} + (h/\lambda) \cos \psi$$

Compton scattering equation

$$\lambda = \lambda_0 + \underbrace{\left[\frac{h}{m_e c} \right]}_{\lambda_C} (1 - \cos \psi)$$

Interaction strengths of x-rays with matter

Compton scattering

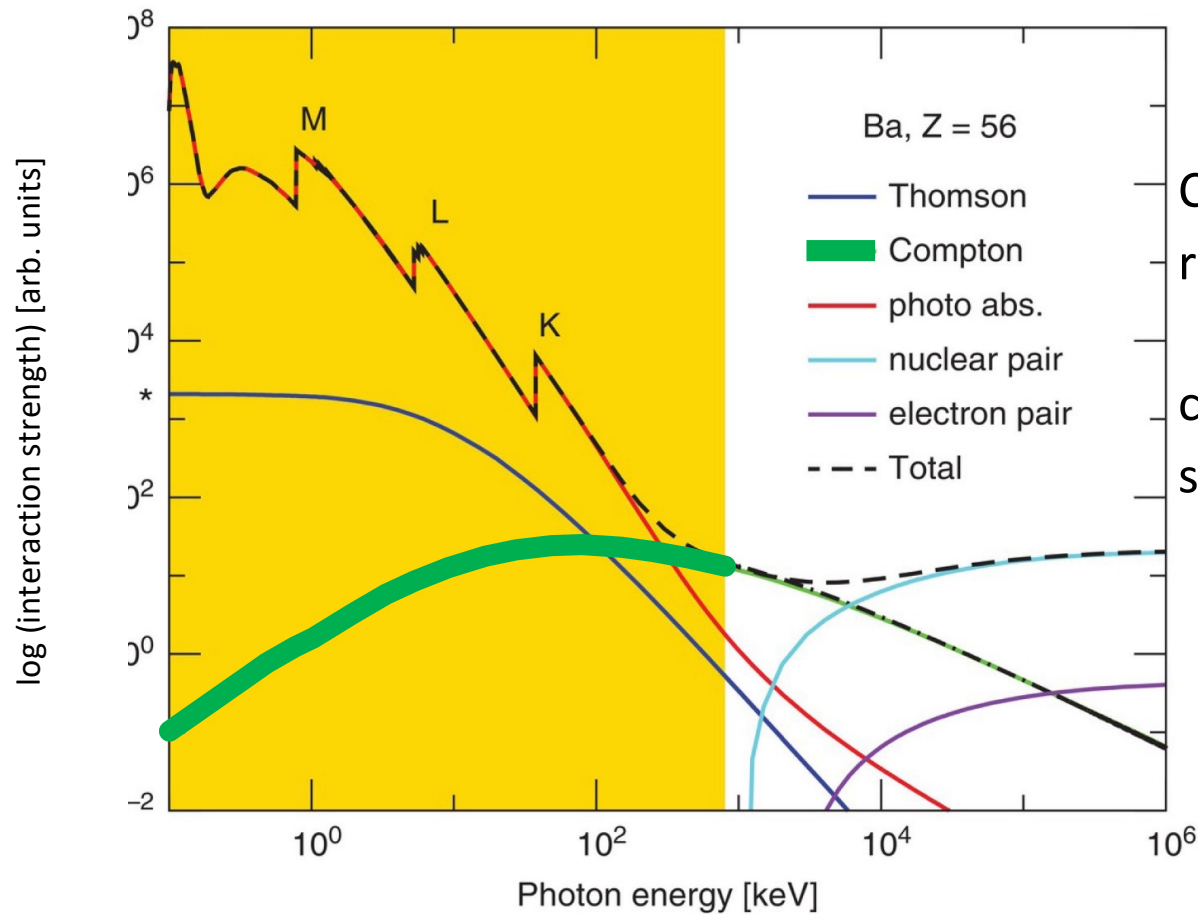

Compton Scattering is only relevant above approx. 100 keV

can give information on electronic structure

Interaction of X-rays and neutrons with matter

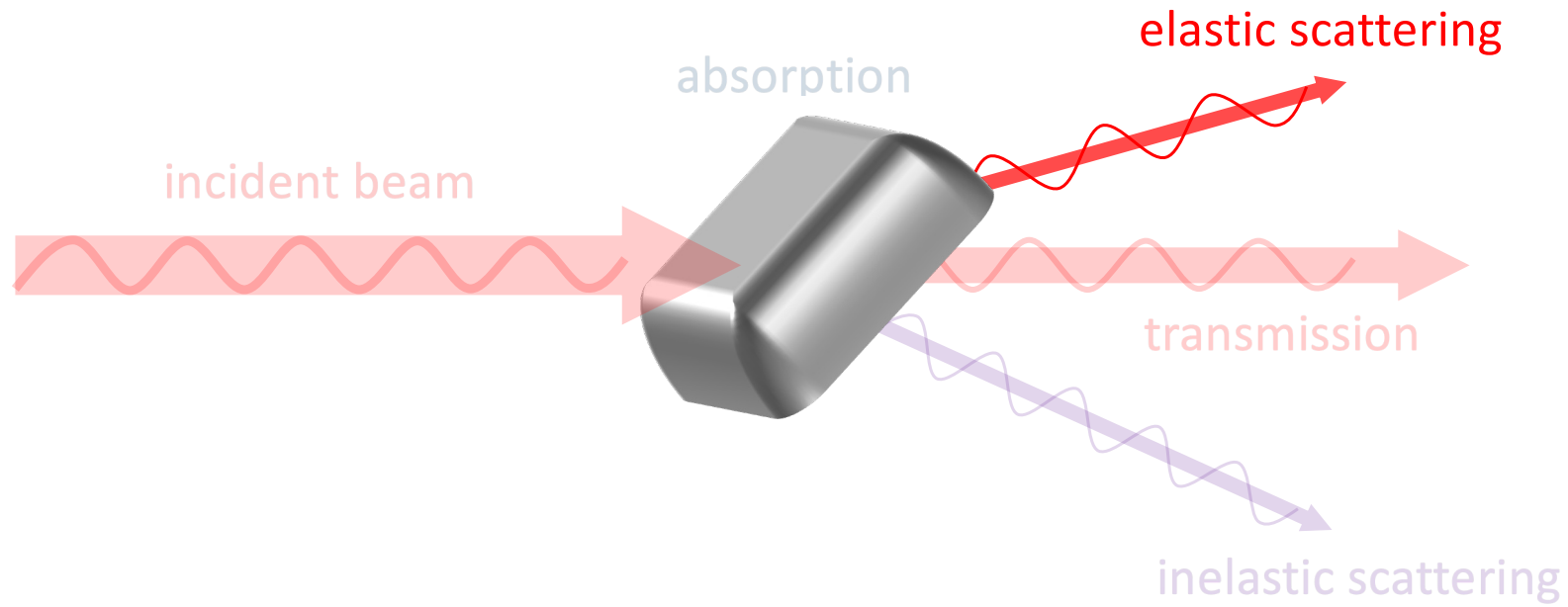

Elastic scattering from a single scatterer

- neutron scattering from a single nuclei

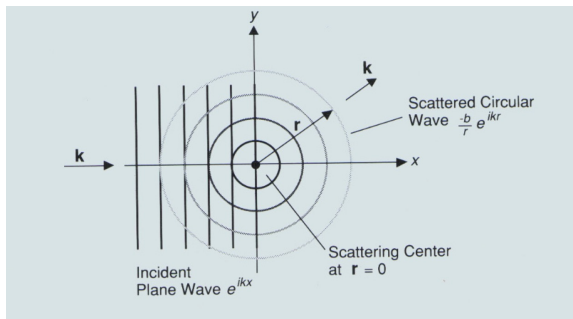

- point scatterer, i.e. isotropic scattering, since the nuclei is very small compared to the wavelength

- X-ray scattering from a single electron Thomson scattering

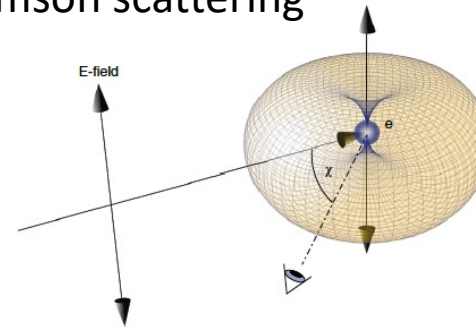

- electromagnetic dipole radiation (non-isotropic)

X-ray scattering from a single electron: Dipole radiation

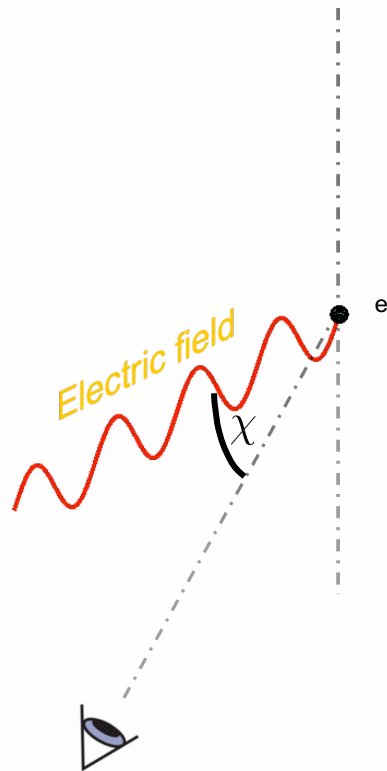

$$I(\chi) = E_0^2 \cos^2 \chi$$

Elastic scattering of photons: Thompson Scattering

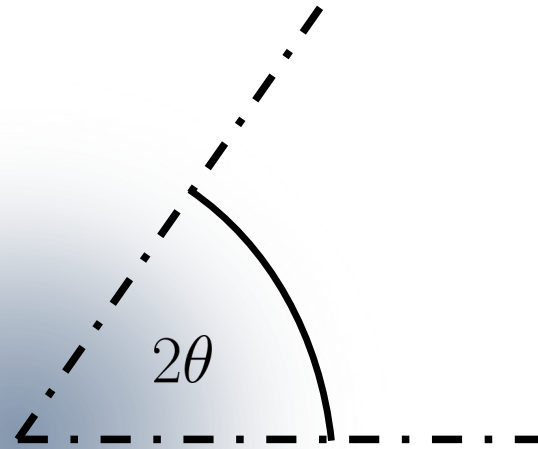

Elastic scattering of photons

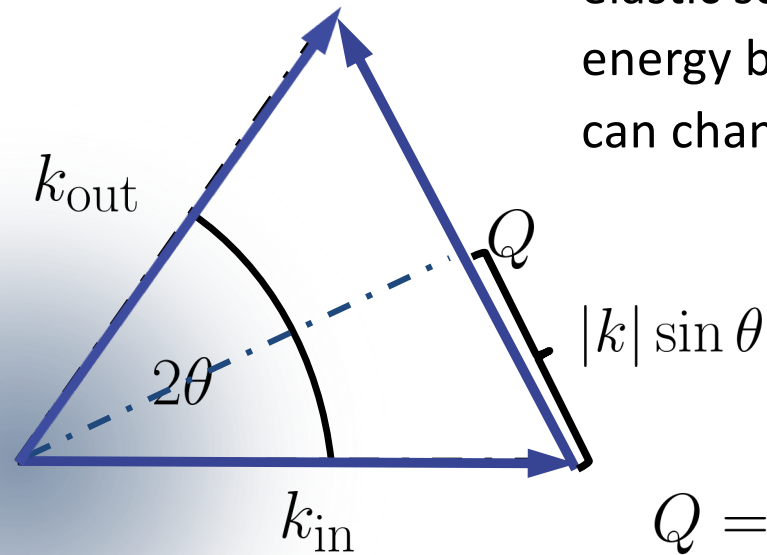

elastic scattering: no loss in photon energy but direction of the photon can change: scattering angle 2θ

$$Q = 2|k| \sin \theta = (4\pi/\lambda) \sin \theta$$

wave vector $k = 2\pi/\lambda$

scattering vector $Q = k_{in} - k_{out}$

Interaction strengths of x-rays with matter

Thomson scattering

energies below ~ 3 keV: $\propto Z^2$
 wavelength is large compared to the size of the electron cloud: all scattering elements scatter coherently

energies above ~ 3 keV $\propto E^{-2}$
 smaller wavelength than size of atom: partially destructive interference reduces cross-section \rightarrow drop off determined by **atomic form factor**

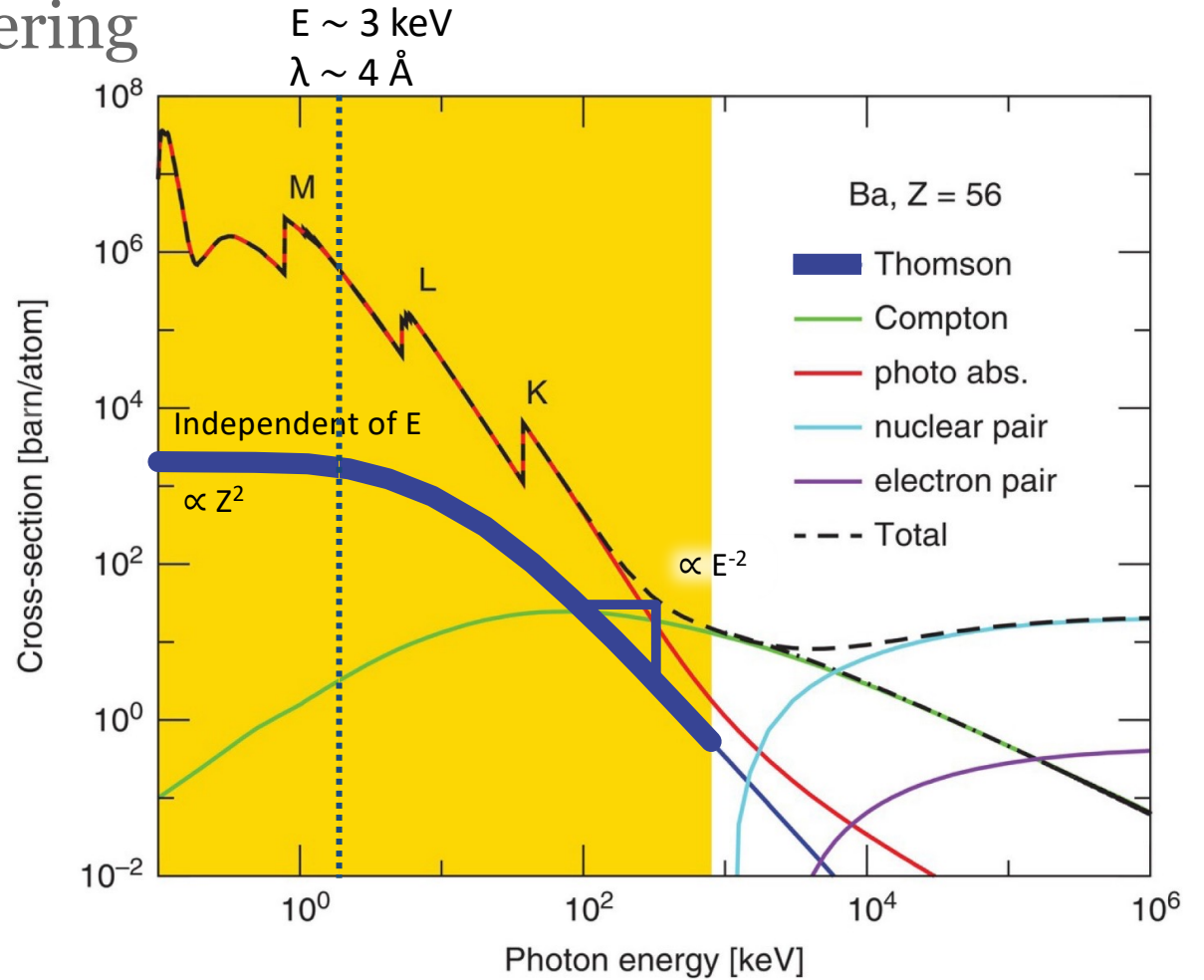

Philip Willmott: Synchrotron and X-ray Free Electron Laser

X-ray scattering from an atom

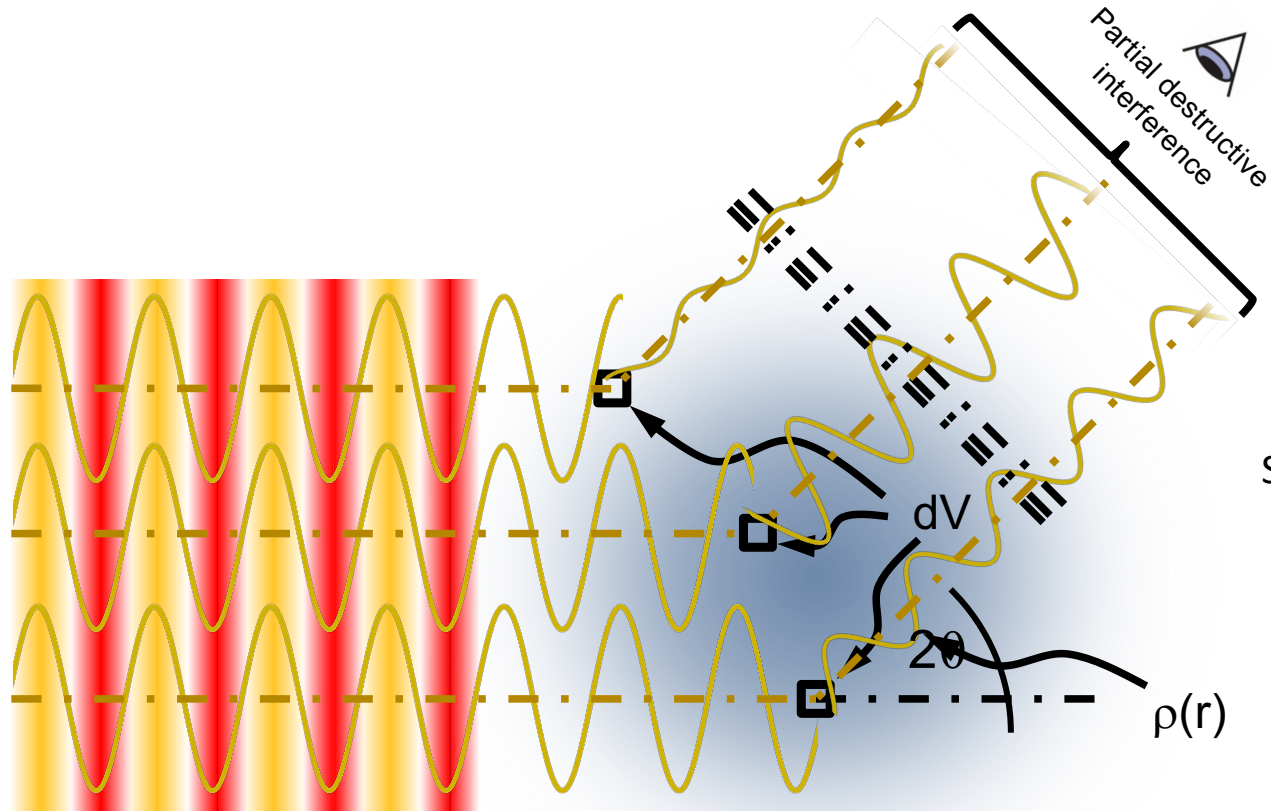

Scattering amplitude decreases with increasing angle 2θ

X-ray scattering from an atom

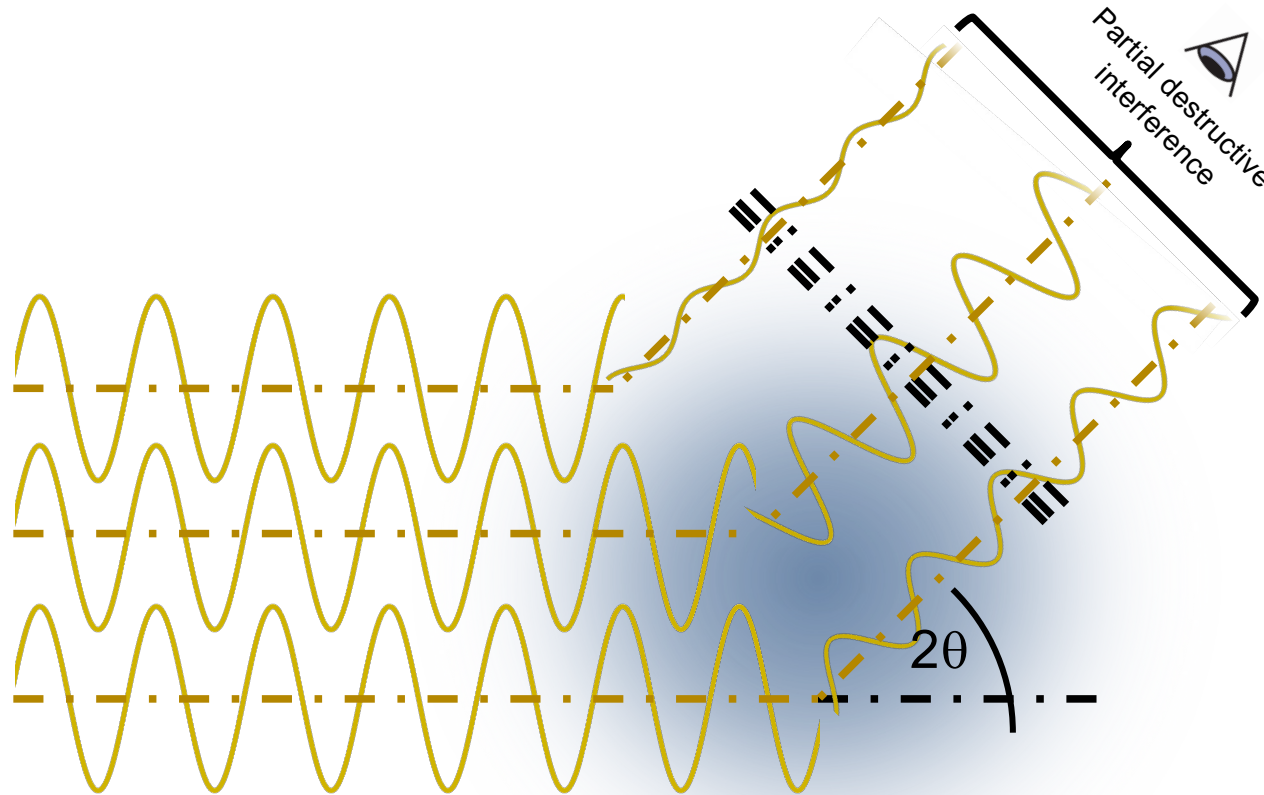

quantify phase difference between scattered radiation from any two dV and integrate contributions from all the volume elements

- scattering amplitude of an atom as a function of the scattering angle and photon energy
- **atomic form/scattering factor**
- Fourier transform of electron density distribution $\rho(r)$

X-ray scattering from an atom

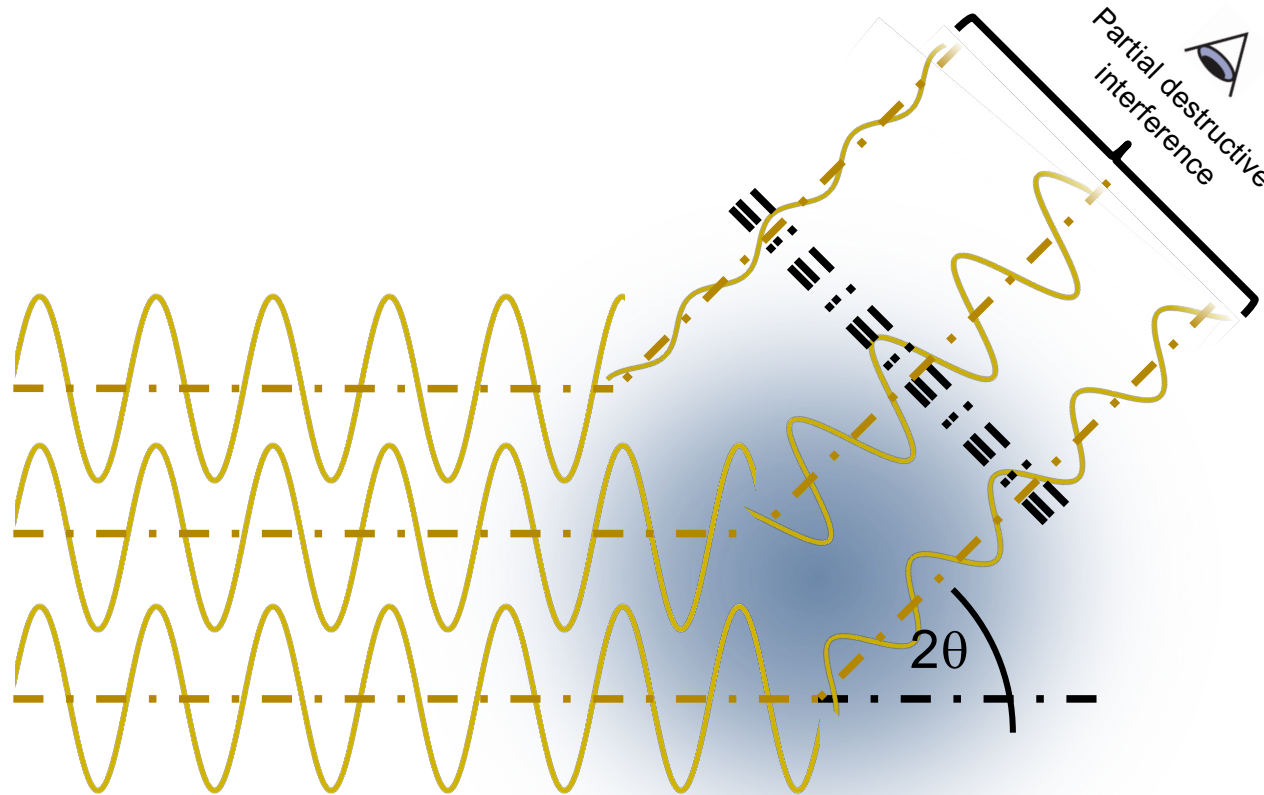

First approximation: assume electrons in cloud around atom are free i.e. unbound to nuclear core (far away from absorption edges)

Second approximation: Fraunhofer approximation: observer (= detector) is far from sample relative to distance within the sample (scattering/diffraction)

Third approximation: Kinematic approximation: sample is a weak scatterer, every photon only scatters once

Elastic scattering and atomic form factor

photon wave length < electron cloud

(a) single electron

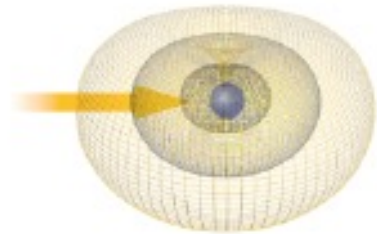

(b) light atom

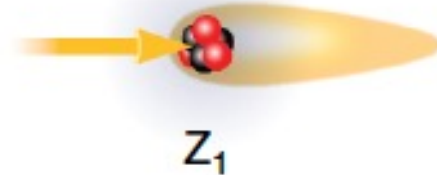

(c) heavy atom

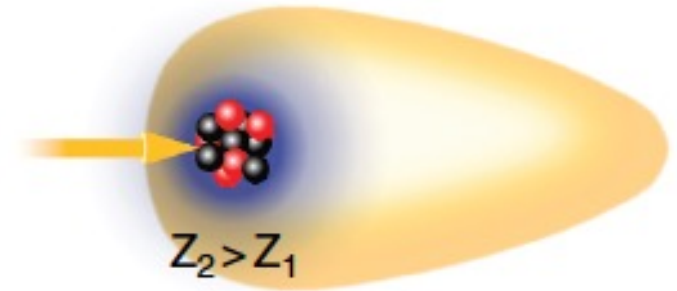

forward direction $f^0(0)$: integral of the electron density over the atom's electron cloud: atomic number Z

for $Q \neq 0$ scattering amplitude decreases with increasing 2θ

drop off is steeper for Z_1 : core electrons are closer to nuclear core, heavy atoms have electron density concentrated in a smaller central volume

Elastic scattering and atomic form factor

atomic form factor $f^0(Q)$ of Phosphorus at different X-ray energies

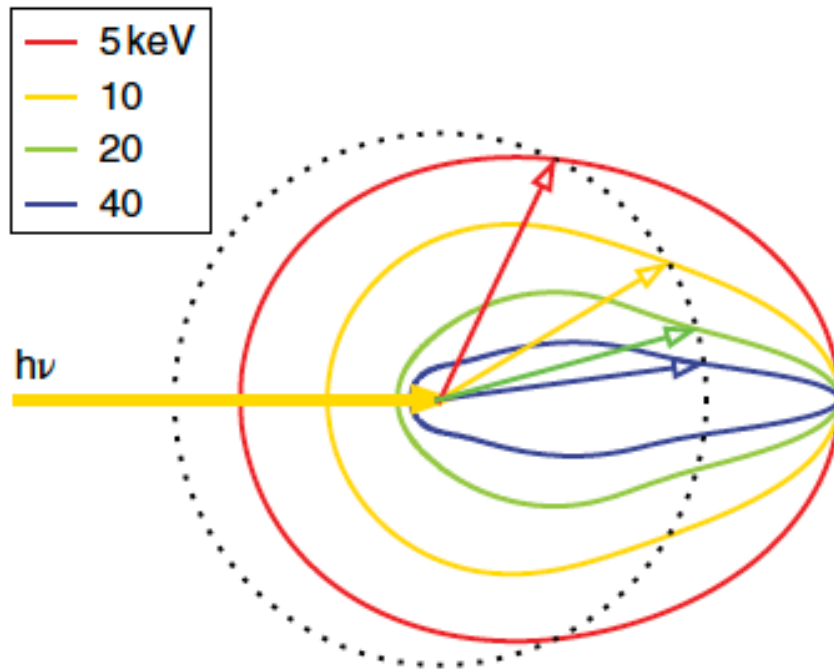

atomic form factors can be found in the International Tables for Crystallography

Willmott, P. (2019). Scattering Techniques. An Introduction to Synchrotron Radiation, John Wiley & Sons, Ltd: 133-221.

Elastic scattering and atomic form factor

atomic form factor $f^0(Q)$ of Phosphorus at different X-ray energies

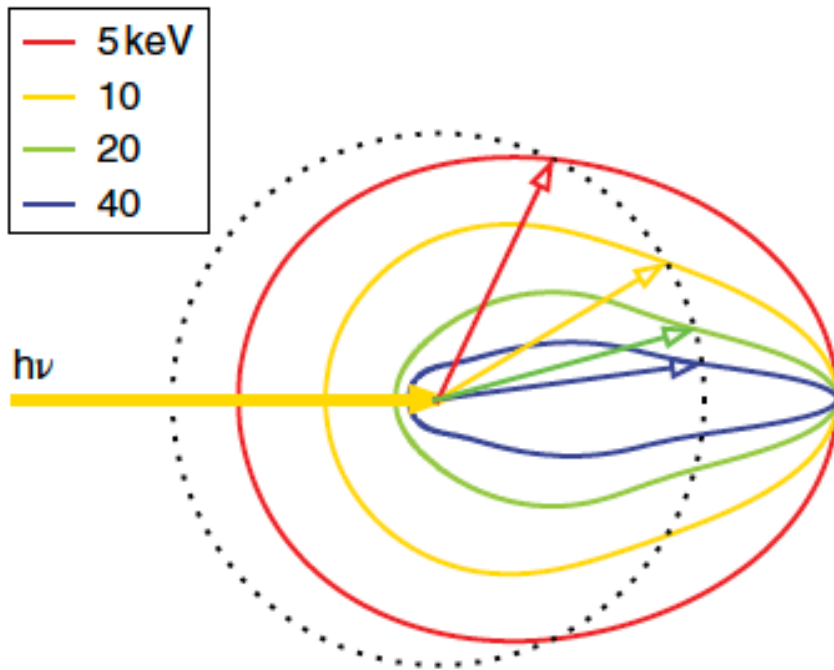

First approximation: assume electrons in cloud around atom are free i.e. unbound to nuclear core

→ valid if photon energy is much larger than the electron binding energy

Willmott, P. (2019). Scattering Techniques. An Introduction to Synchrotron Radiation, John Wiley & Sons, Ltd: 133-221.

Atomic response to x-rays

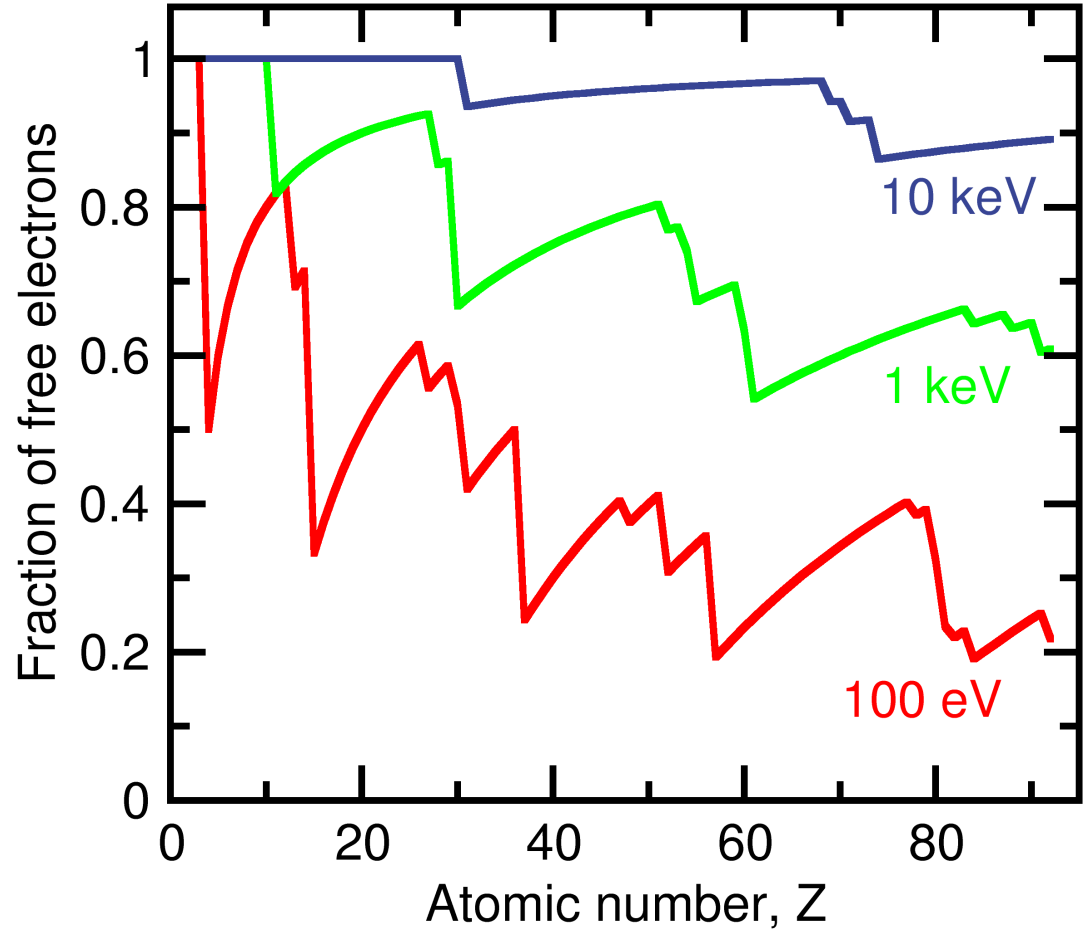

Most electrons in atoms can be considered to be quasi “free” for photon energy > 1 keV

Philip Willmott: Synchrotron and X-ray Free Electron Laser

Elastic scattering and atomic form factor

atomic form factor $f^0(Q)$ of Phosphorus at different X-ray energies

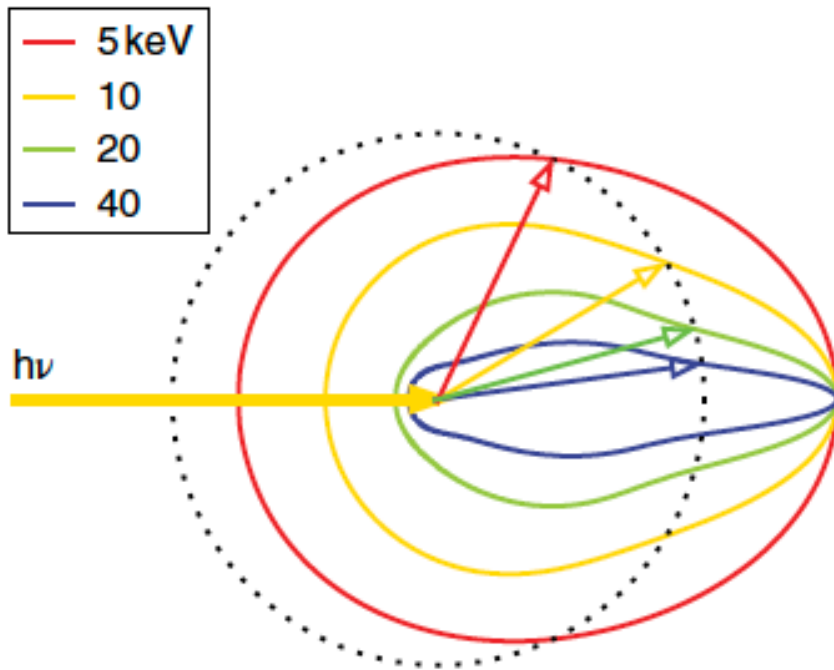

First approximation: assume electrons in cloud around atom are free i.e. unbound to nuclear core

→ valid if photon energy is much larger than the electron binding energy

to account for electrons being bound adding of energy-dependent terms to the atomic form factor:

$$f(Q, \hbar\omega) = f^0(Q) + f'(\hbar\omega) + if''(\hbar\omega)$$

Willmott, P. (2019). Scattering Techniques. An Introduction to Synchrotron Radiation, John Wiley & Sons, Ltd: 133-221.

Bound electrons' response to x-rays

$\omega_0 = E_B/\hbar$ natural oscillation frequency for a defined binding energy

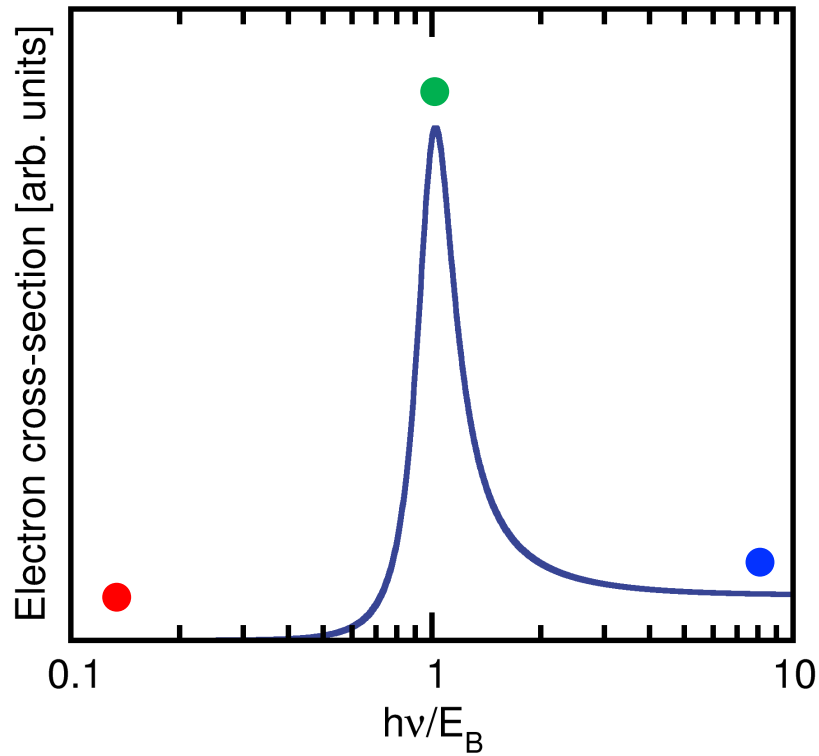

$\hbar\omega \gg E_B$

Electron quasi "free"

Bound electrons' response to x-rays

$\omega_0 = E_B/\hbar$ natural oscillation frequency for a defined binding energy

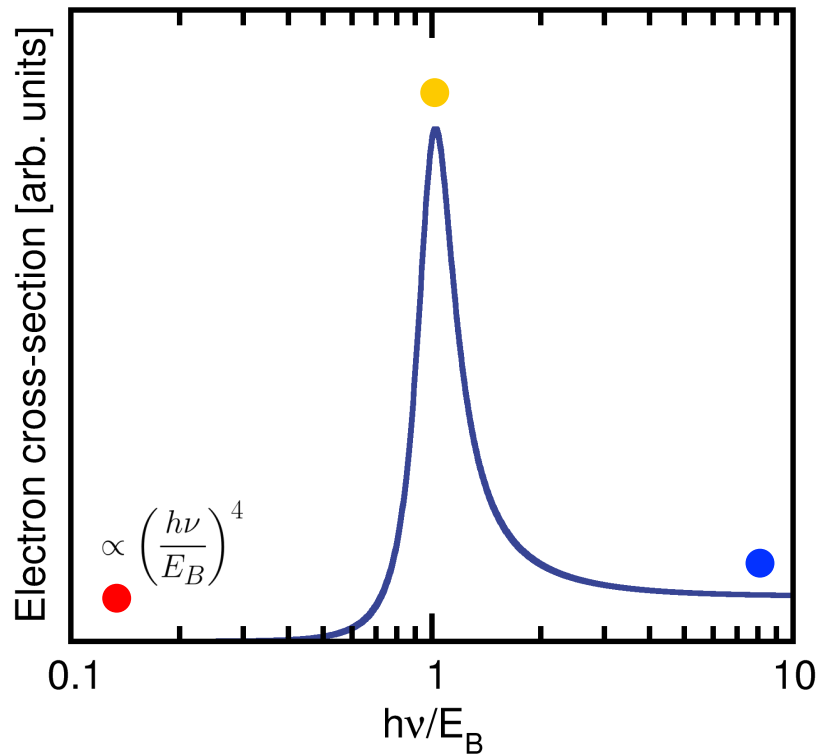

$\hbar\omega \ll E_B$

Response strongly suppressed ~ 0
"Rayleigh scattering"

$\hbar\omega \gg E_B$

Electron quasi "free"

$\hbar\omega \simeq E_B$

Resonance
Enhanced response
dissipation (absorption)

Philip Willmott: Synchrotron and X-ray Free Electron Laser

Correction terms to the atomic form factor: f'

$$f_1(Q, \hbar\omega) = f^0(Q) + f'(\hbar\omega) \quad f'(\hbar\omega) < 0$$

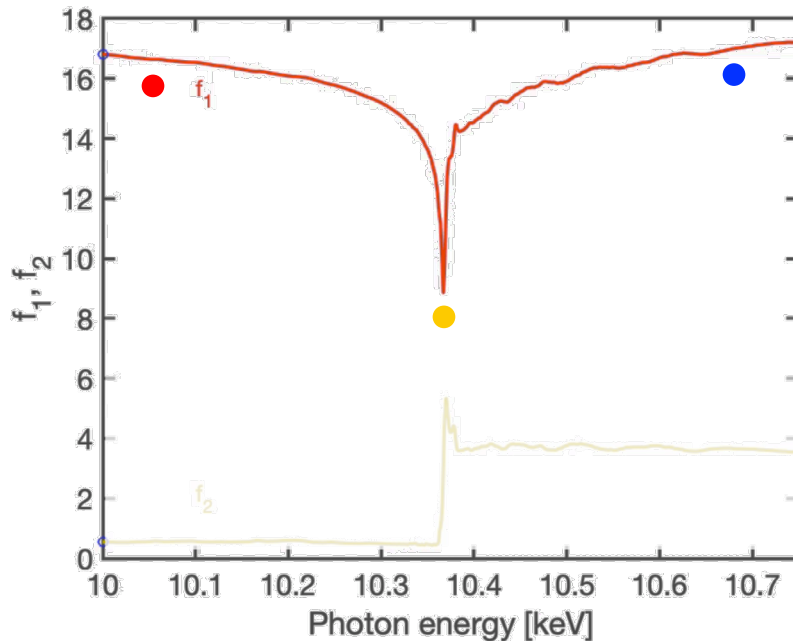

$$\hbar\omega < E_B$$

Reduced response from those electrons that are bound \Rightarrow small reduction in scattering factor

Add **negative** component f'

f' a function of $\hbar\omega$

$$\hbar\omega \gg E_B$$

Electron quasi “free”

$$f' \Rightarrow 0$$

$$\hbar\omega \simeq E_B$$

Resonance

Enhanced response \Rightarrow maximal $|f'|$

\rightarrow **decreased scattering strength**

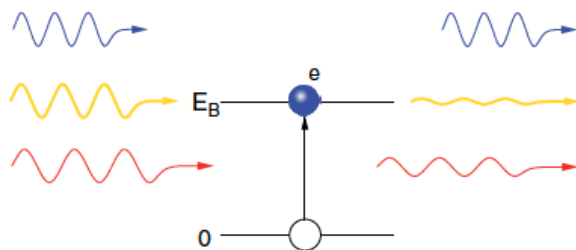

Correction terms to the atomic form factor: f''

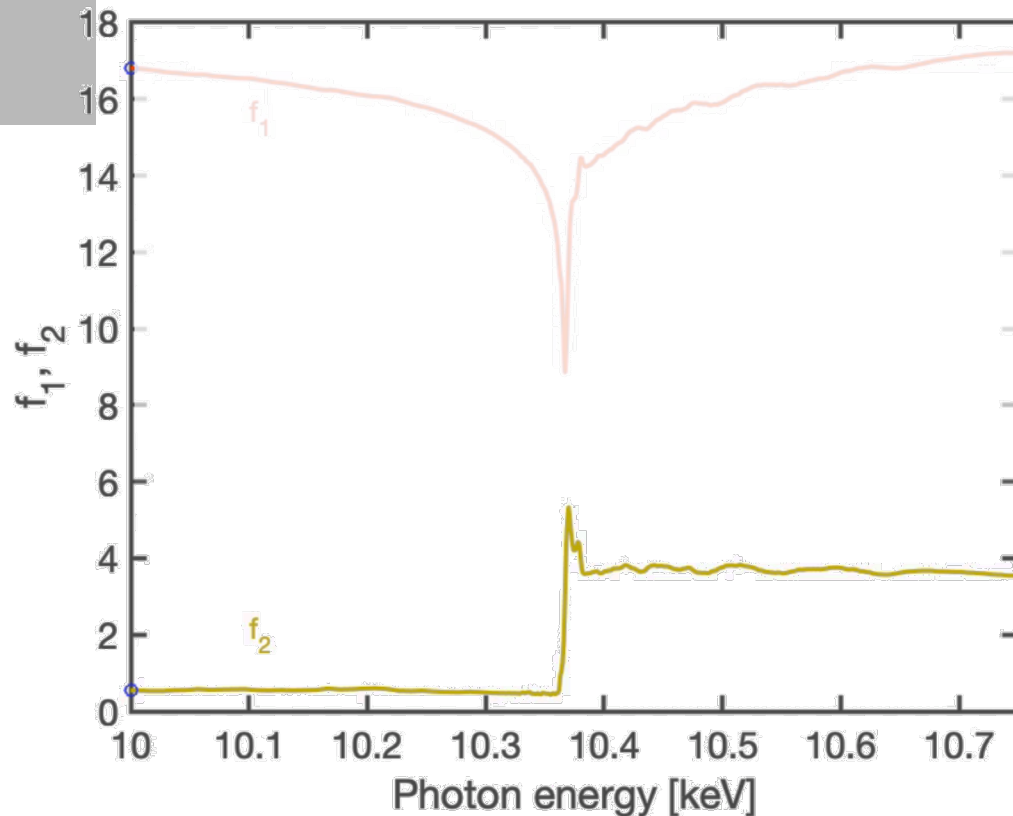

the absorption cross-section

$$f_2 = f'' = \frac{\sigma_a}{2\lambda r_0}$$

$$\hbar\omega \simeq E_B$$

Resonance

Enhanced response \Rightarrow maximal $|f'|$

Phase shift @ resonance = $\pi/2$

Express as imaginary component f''

Results in energy dissipation (absorption)

complex atomic form factor

$$f(Q, \hbar\omega) = \underbrace{f^0(Q)}_{f_1(Q, \hbar\omega)} + \underbrace{f'(\hbar\omega) + if''(\hbar\omega)}_{f_2(\hbar\omega)}$$

complex atomic form factor for Si

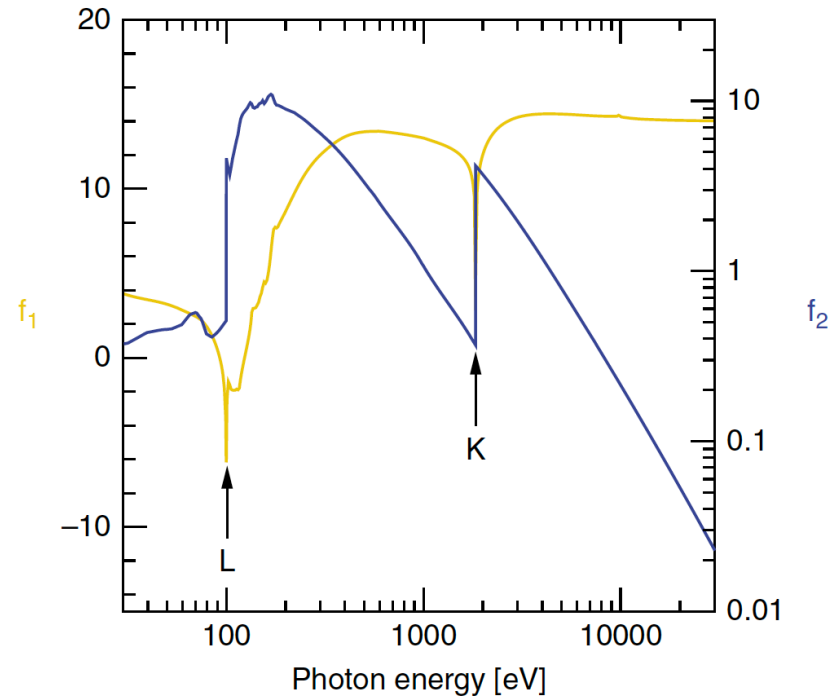

Interaction of X-rays with matter

interaction with electrons

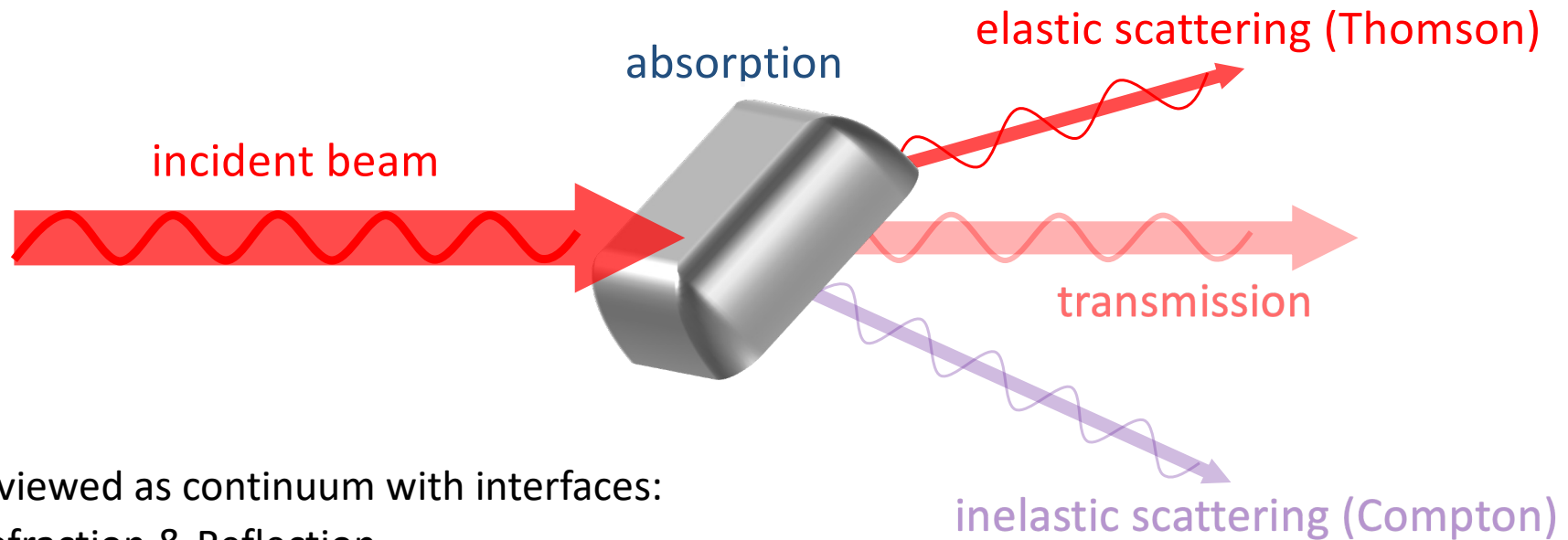

if viewed as continuum with interfaces:
Refraction & Reflection

scattering and refraction descriptions are equivalent

Refraction

$$n_R = \frac{c}{v_p}$$

$$\lambda_{n_R} = \lambda_0 / n_R$$

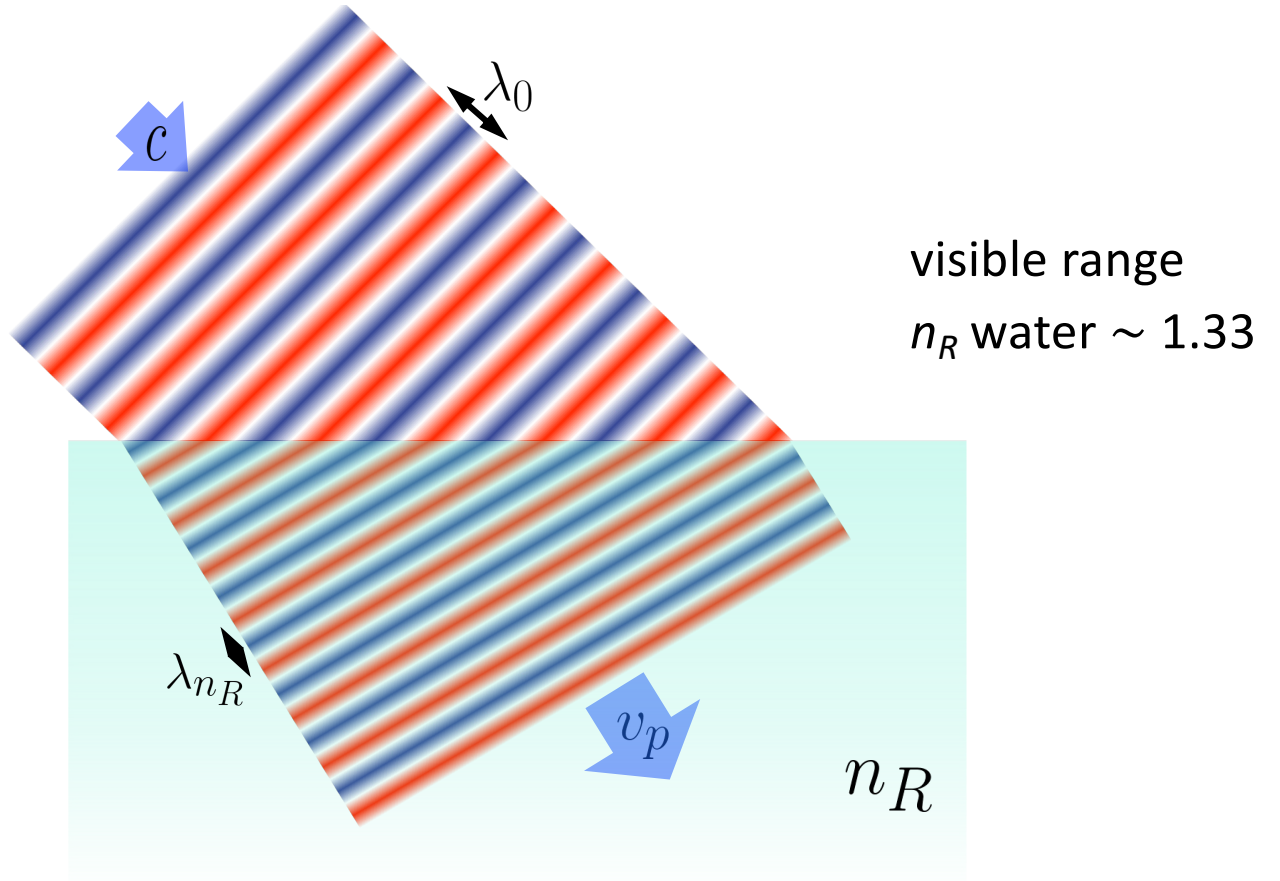

Change in n with photon energy

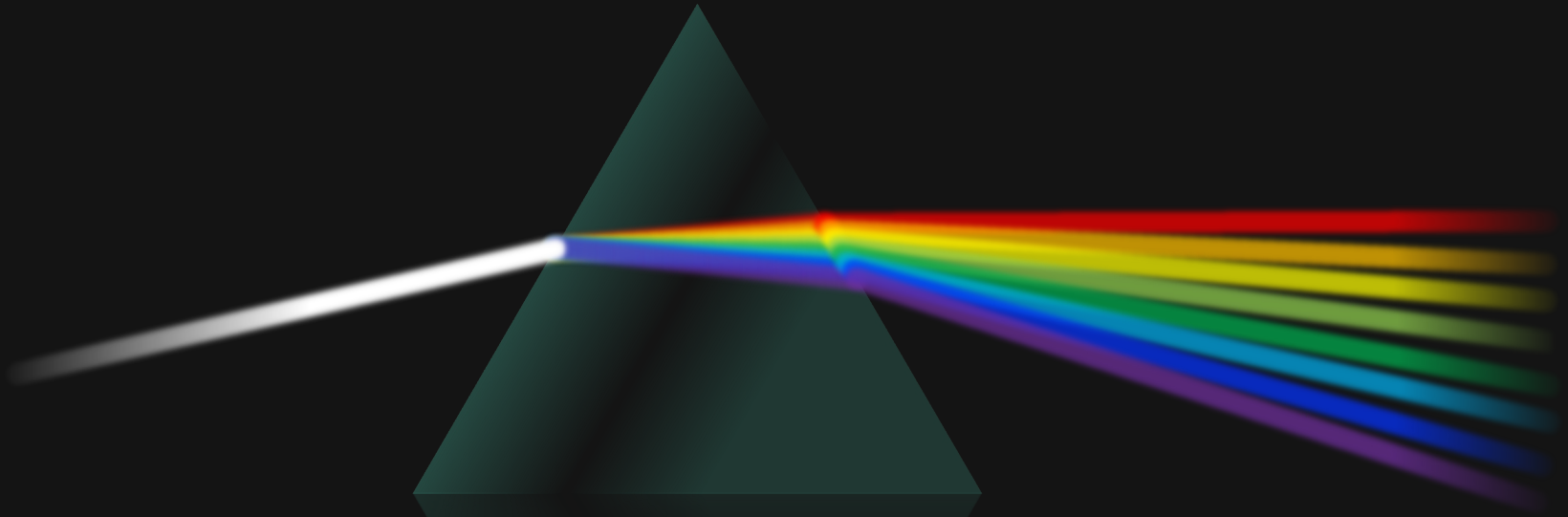

Complex refractive index for X-rays

$$n = n_R + in_I = 1 - \delta + i\beta$$

Refraction – the bending of light as it passes from one medium to another.

Absorption – attenuation of light by photoexcitation of electrons

refractive-index decrement

absorption index

Reflectivity

$$n = 1 - \frac{r_0}{2\pi} \lambda^2 \sum_i N_i f_i(0) \quad \text{related to the complex atomic form factor !}$$

far away from an absorption edge (ignoring f'')

= ρ average density of electrons

Refractive index in the x-ray regime

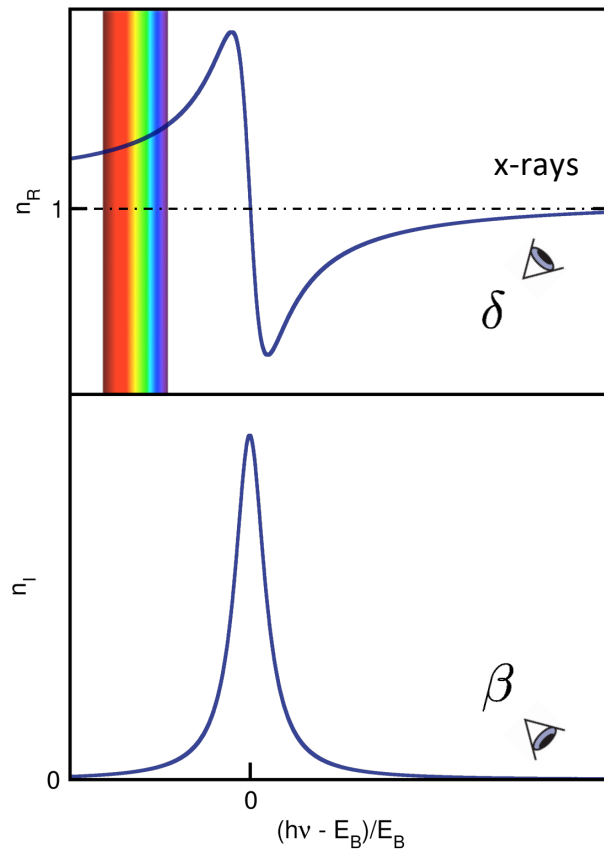

well above resonance:

$$n = n_R + in_I = 1 - \delta + i\beta$$

refractive-index
decrement

absorption index

n_R for X-rays < 1

deviation from 1 ($= \delta$) in the order of 10^{-4} to 10^{-6}

refractive index for neutrons

we consider here only the interaction with nuclei, and skip the magnetic part

$$n = \sqrt{1 - \frac{\lambda^2 \rho}{\pi}} \quad n < 1 \text{ for almost all materials the refractive index for thermal neutrons}$$

deviation from 1 in the order of 10^{-5}

scattering length density of neutrons

$$\rho = \frac{1}{V} \sum_j b_j \quad b_j: \text{coherent scattering length of all atoms (nuclei) in one unit of volume } V$$

complex scattering length b

$$b = b' - ib'' \quad b'' \text{ imaginary part of the scattering length for Neutron absorption (can be mostly neglected)}$$

$$b'' = \left(\frac{k}{4\pi}\right) \sigma_a(k) \text{ with } \sigma_a \text{ the absorption cross section}$$

Snell's law



$$\frac{\cos \alpha}{\cos \alpha'} = \frac{n_R'}{n_R}$$

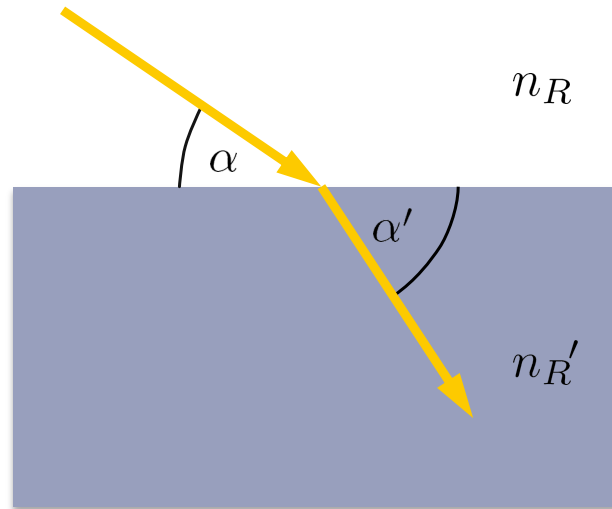

Refractive index: visible light, x-rays, neutrons

Visible

$$n_R > 1.0$$

Light bent to **steeper** angles when entering denser medium

at angles smaller than the critical angle \rightarrow **total internal reflection**

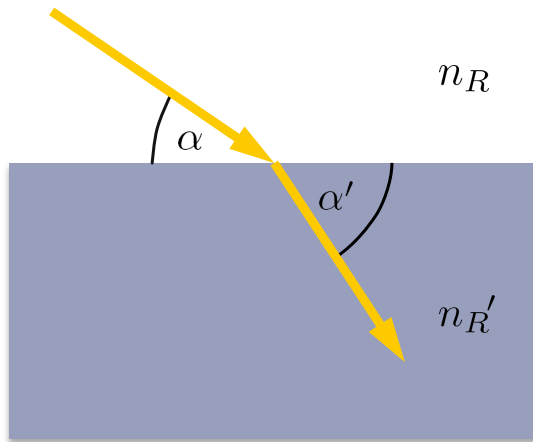

X-rays

$$n_R = 1 - \delta < 1.0$$

X-rays and neutron bent to **shallower** angles when entering denser medium

at angles smaller than the critical angle \rightarrow **total external reflection**
 deviation from 1 is very small (10^{-4} - 10^{-6}) the critical angle is very small

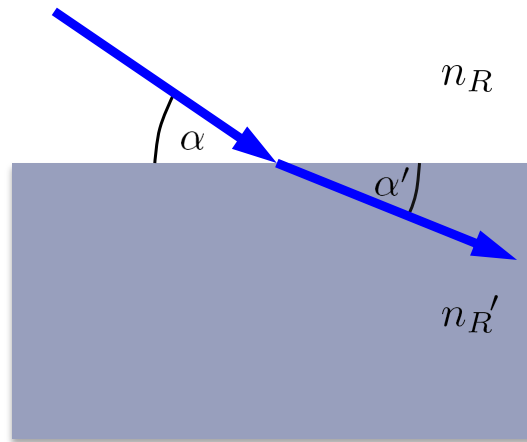

neutrons

$$n_R < 1.0$$

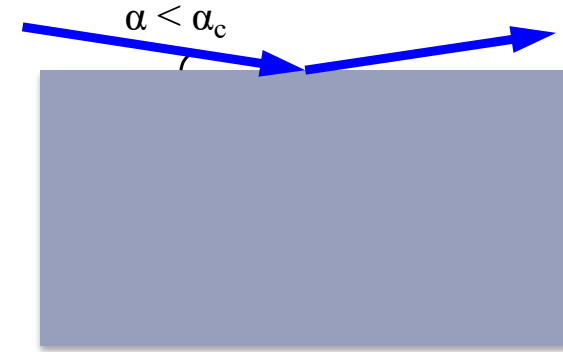

Philip Willmott: Synchrotron and X-ray Free Electron Laser

Refractive index: visible light vs x-rays

focusing lenses

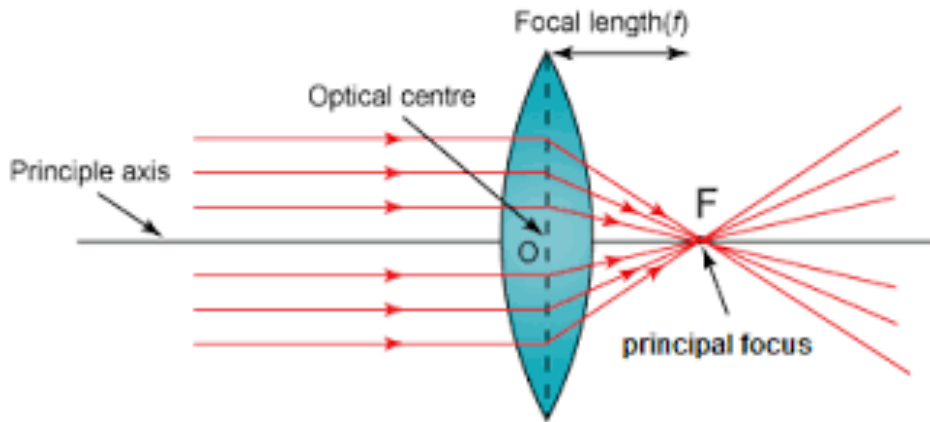

convex lense for focusing in the visible

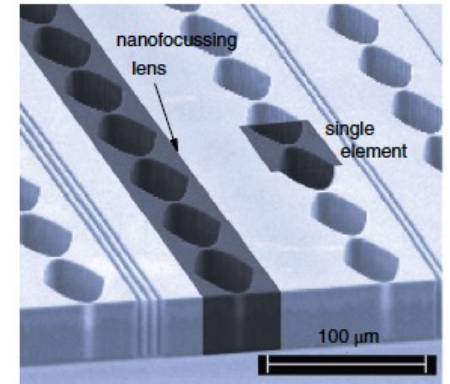
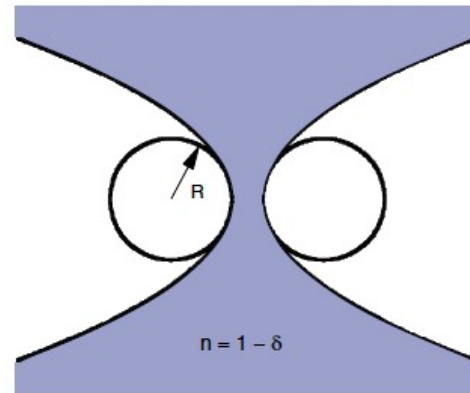

nanofocussing parabolic compound refractive lenses

Interaction of X-ray with matter

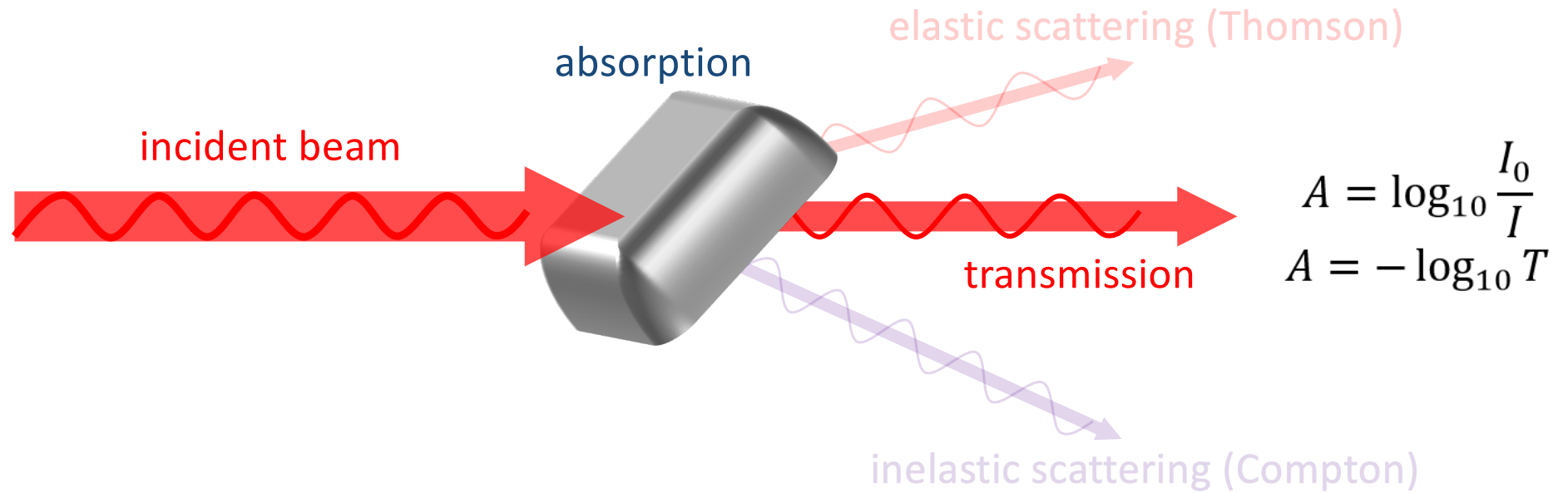

Interaction strengths of x-rays with matter

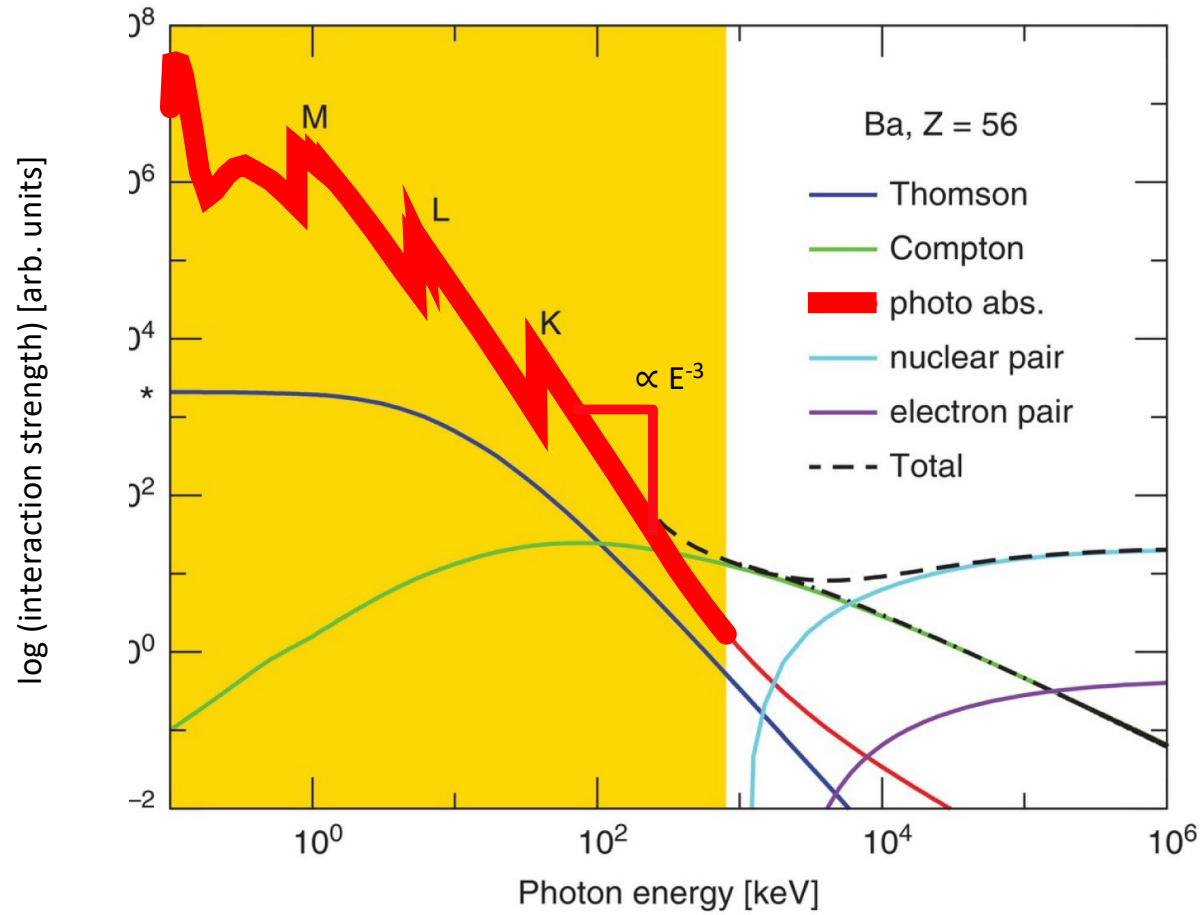

Philip Willmott: Synchrotron and X-ray Free Electron Laser

Photoelectrons and fluorescence

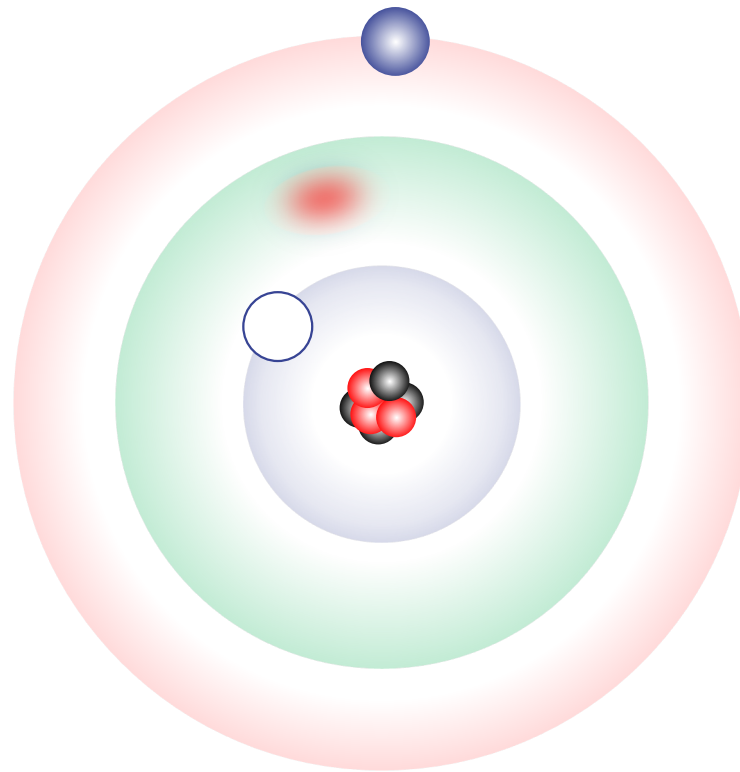

Photoelectron

$$KE = h\nu_{in} - E_B$$

Fluorescence

$$h\nu_{in} > h\nu_{out}$$

$$h\nu_{out} = E_{B,1} - E_{B,2}$$

Auger electrons

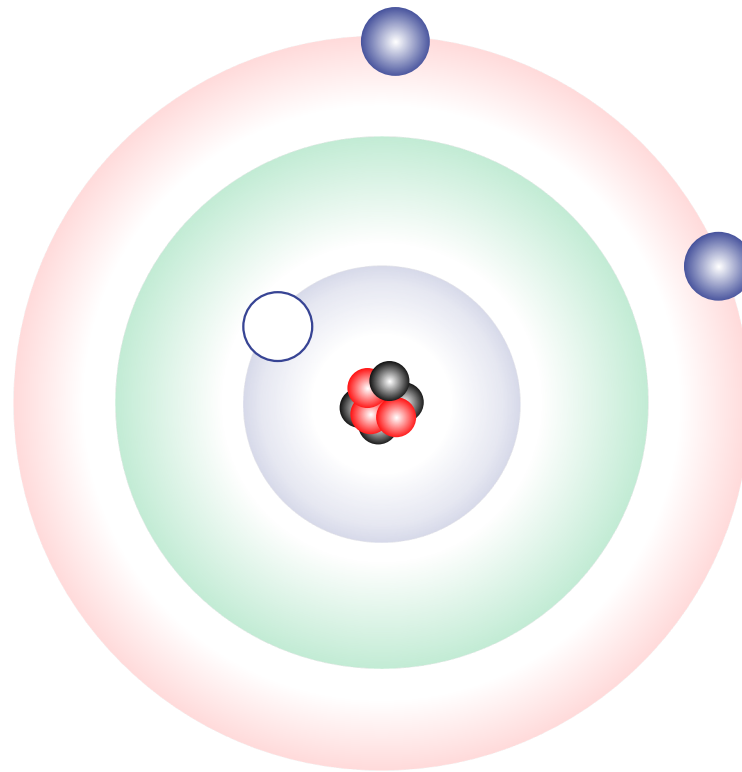

Photoelectron

$$KE = h\nu_{in} - E_B$$

Auger-electron

KE independent of $h\nu$

Fluorescence or Auger?

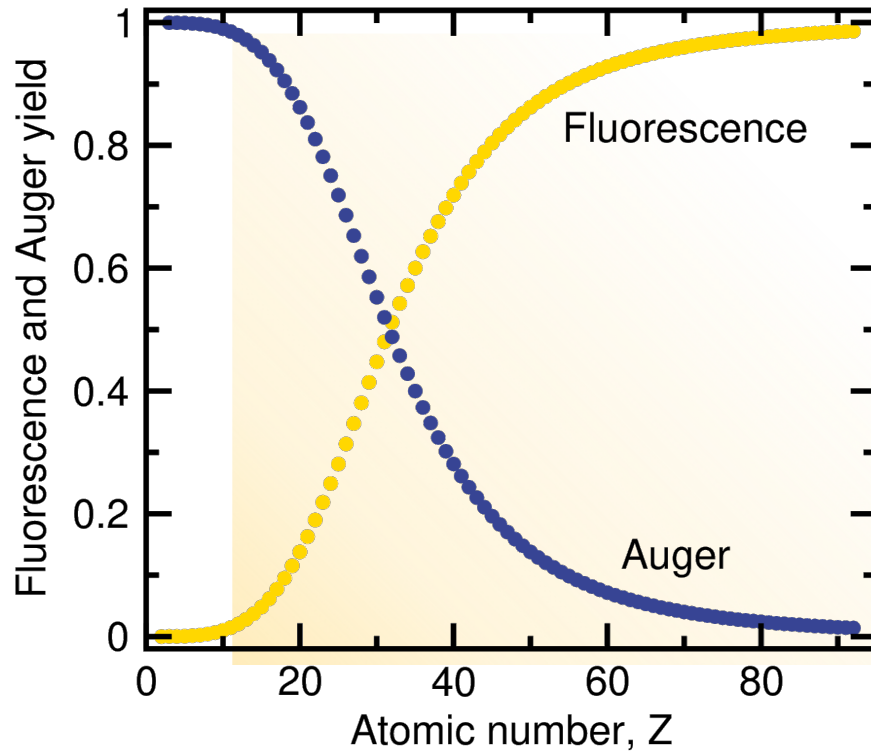

probability for fluorescence depends on relaxation energy

$$p_{fl} \propto (h\nu)^3$$

yield for K-shell fluorescence (empirically):

$$Y_K = \frac{Z^4}{10^6 + Z^4}$$

Secondary electrons

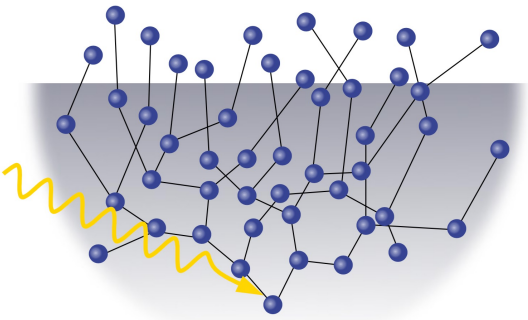
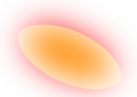

Cascade process

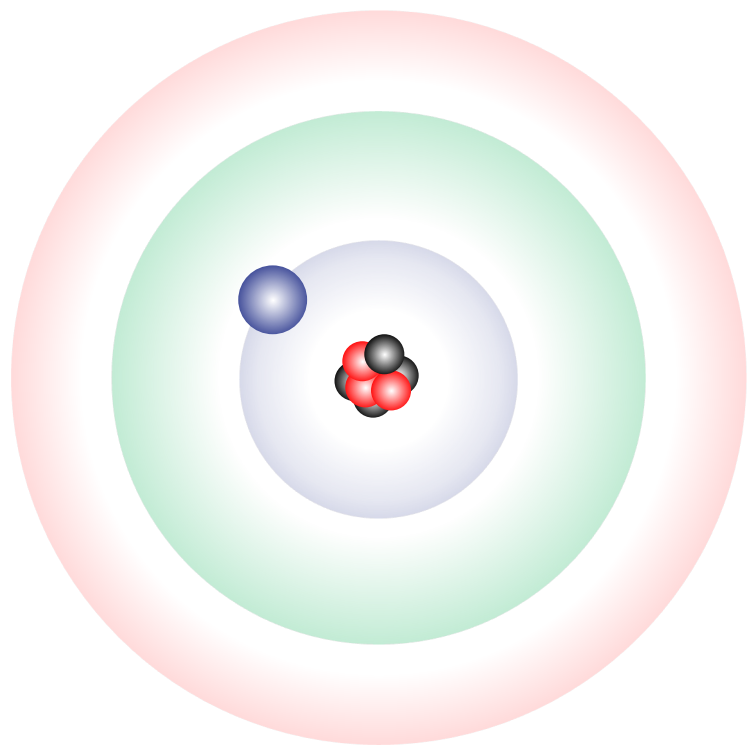

Thermalization
KE ~ 1 eV or smaller

Interaction of X-ray with matter

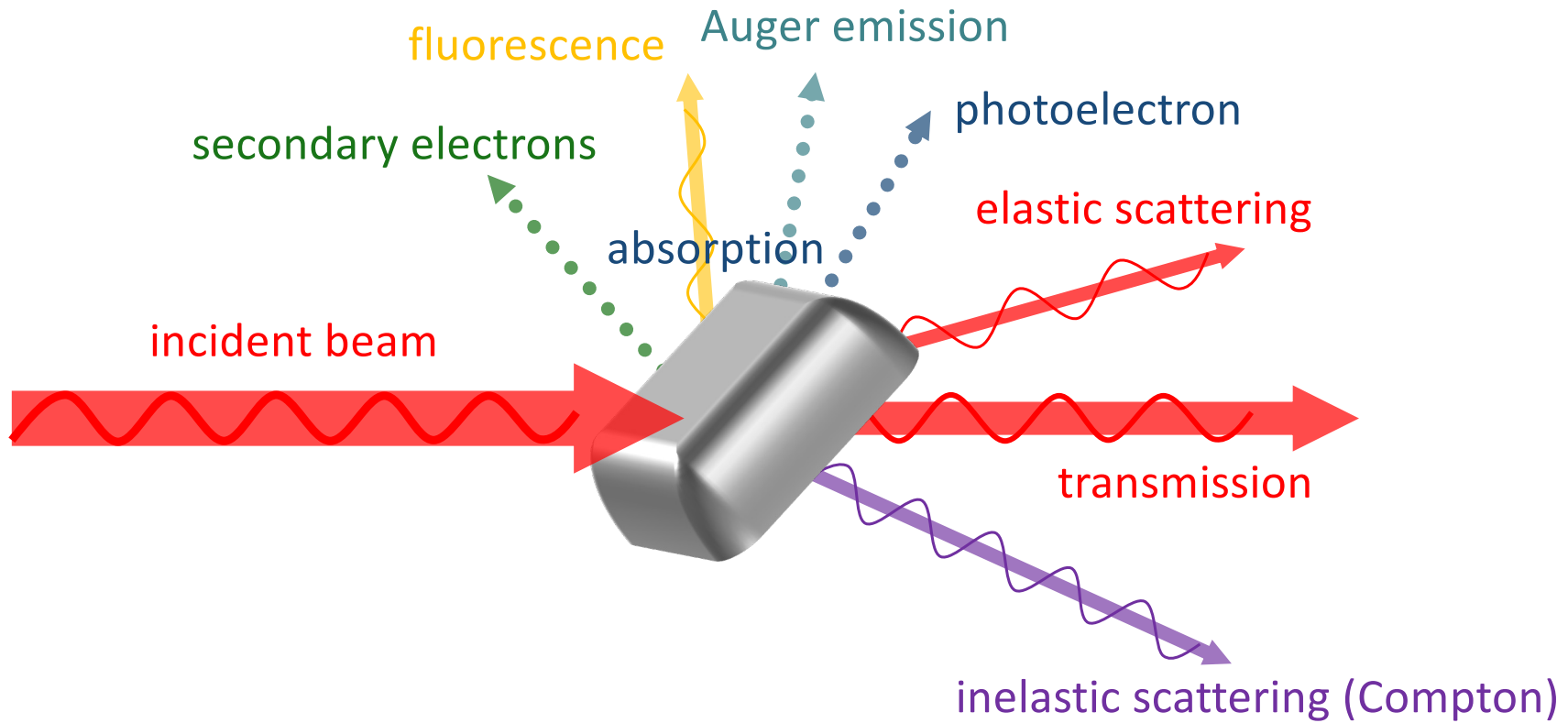

Interaction of X-ray with matter

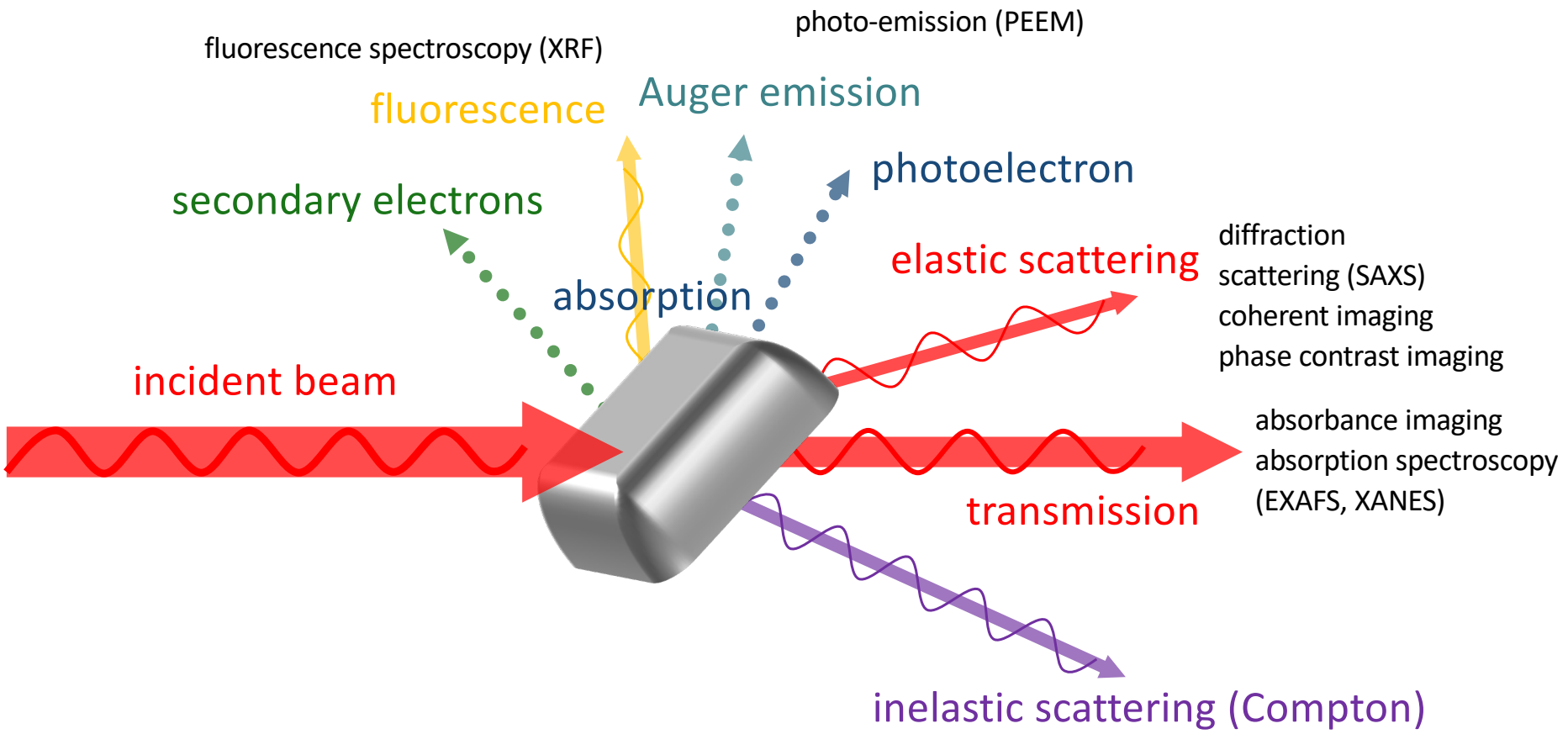

Interaction of neutrons with matter

interaction with nuclei (& magnetic moment)

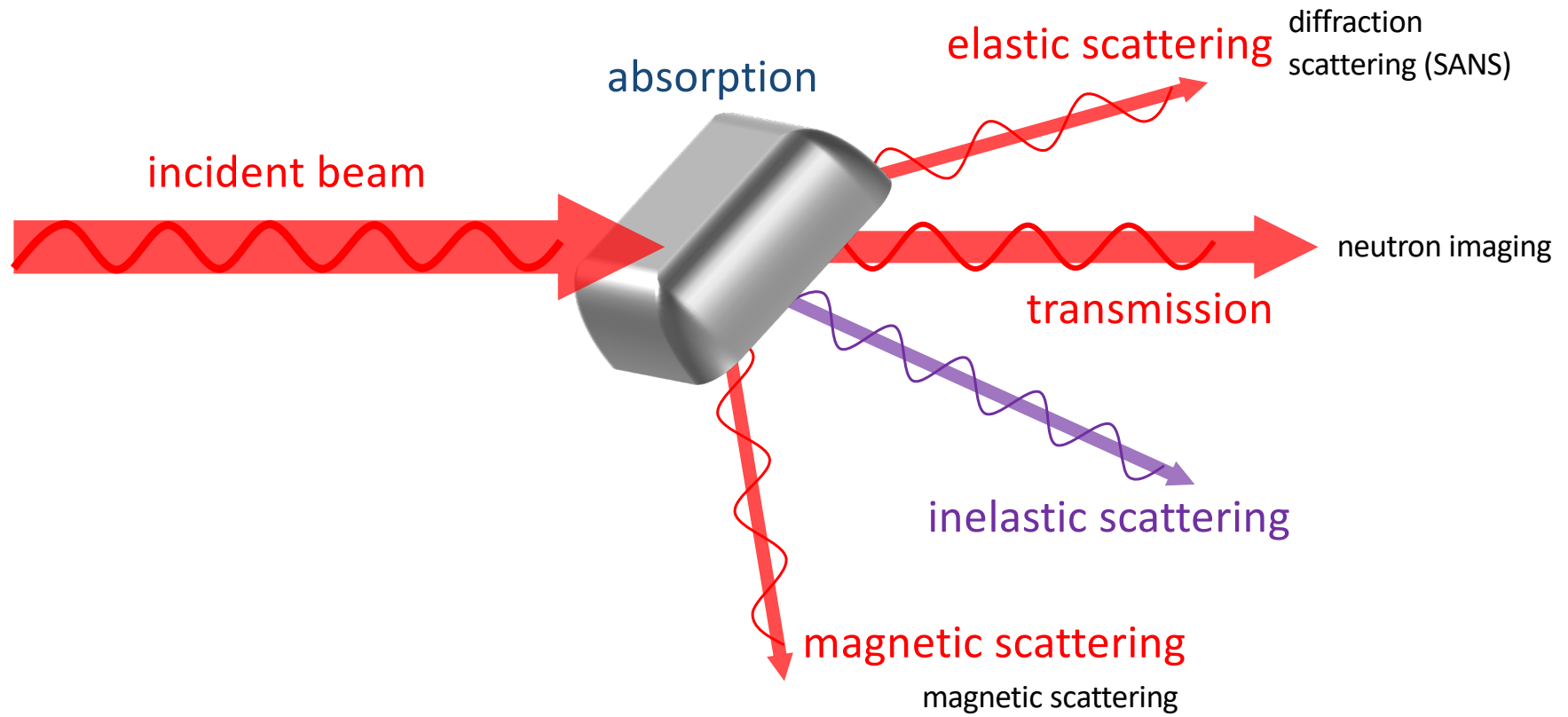

Why X-rays and Neutrons: Transparency

→ investigate nondestructively internal 3D structure of heterogenous samples

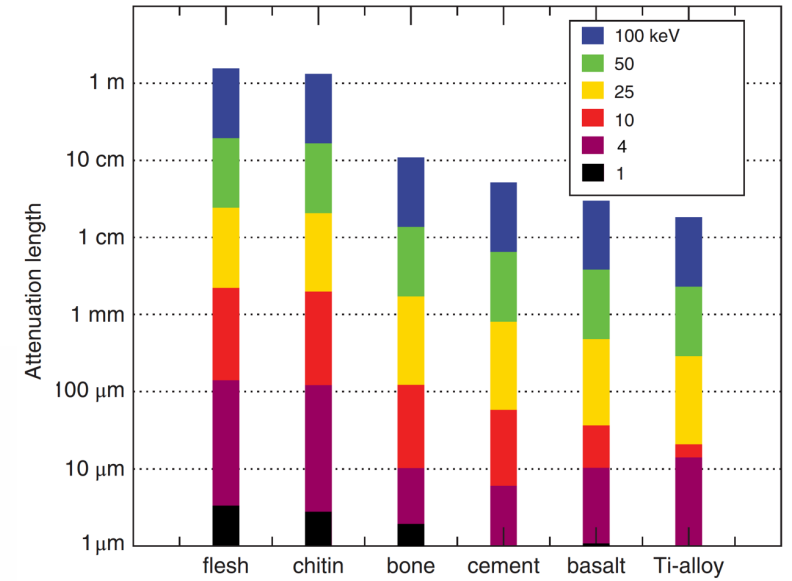
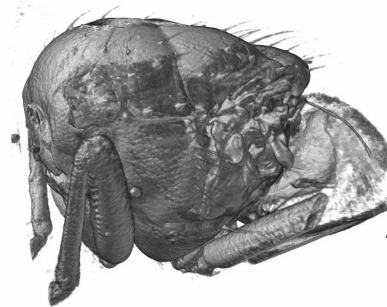
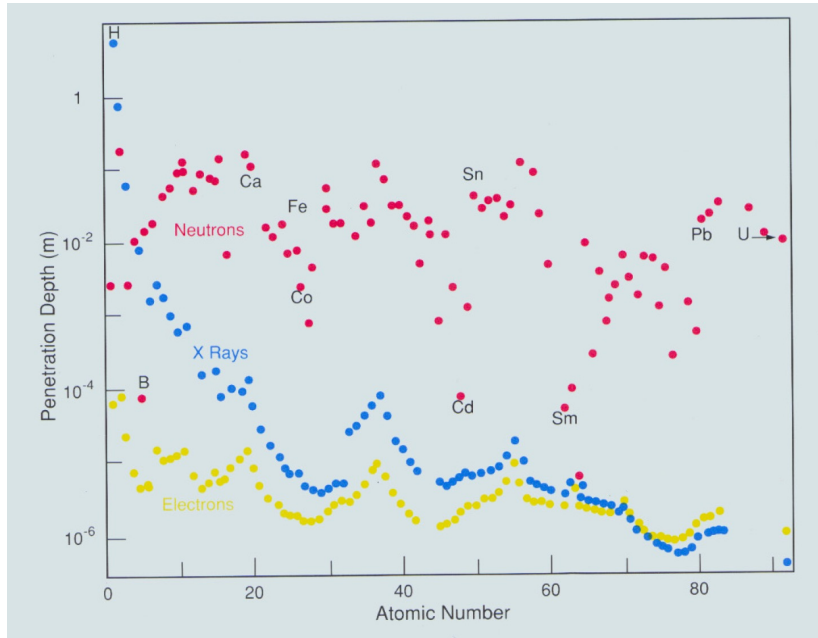

Attenuation lengths of different materials over two orders of magnitude x-ray photon energy

<https://www.ncnr.nist.gov/summerschool/ss16/pdf/NeutronScatteringPrimer.pdf>

Why X-rays and neutrons: Abbe-limit

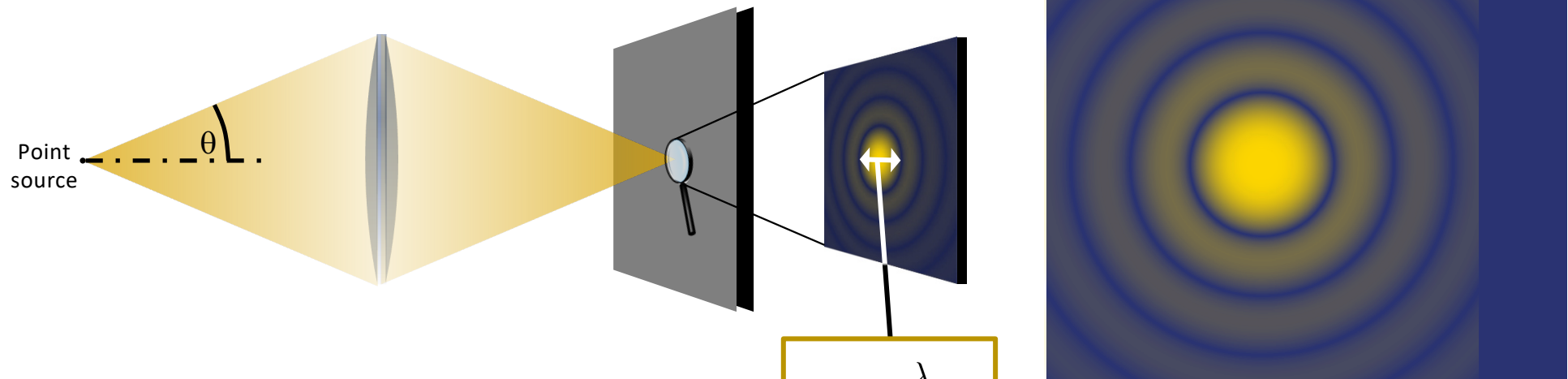

$$d = \frac{\lambda}{2n \sin \theta}$$

visible: $d \sim \lambda/2$
 x-rays: $d \sim 20 \lambda$ ($\because \sin \theta$ is small)

Why X-rays and neutrons

smaller wavelength \rightarrow higher resolution

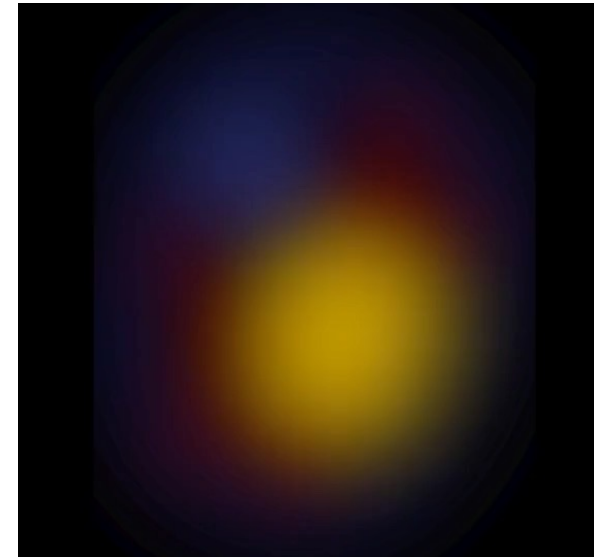
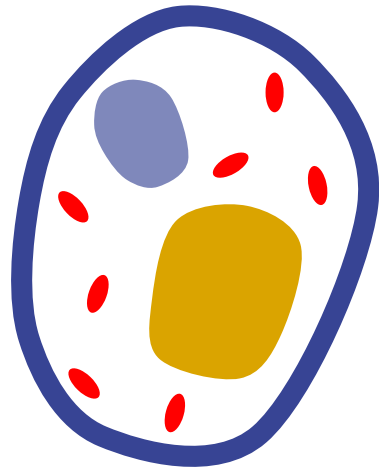

Decreasing wavelength



Why x-rays: interactions with specific electrons

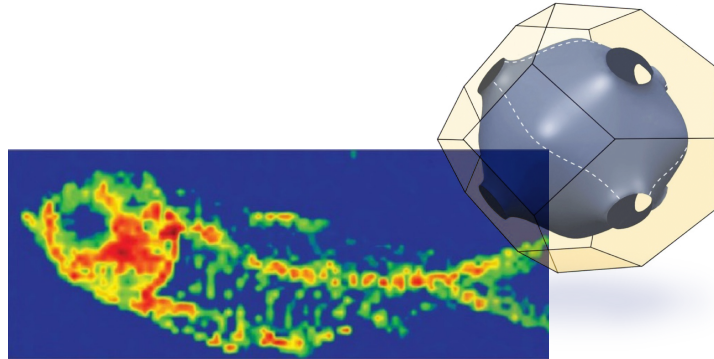
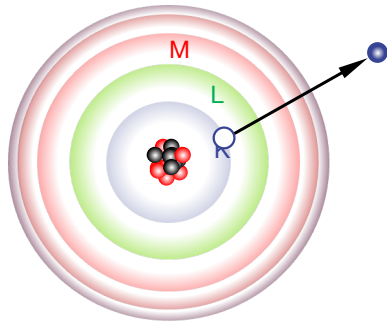

- chemical and elemental composition
- electronic properties
- magnetic domains

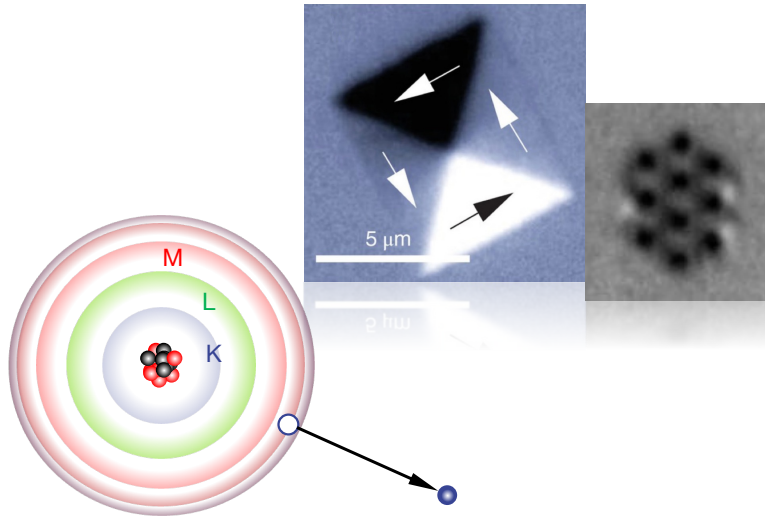
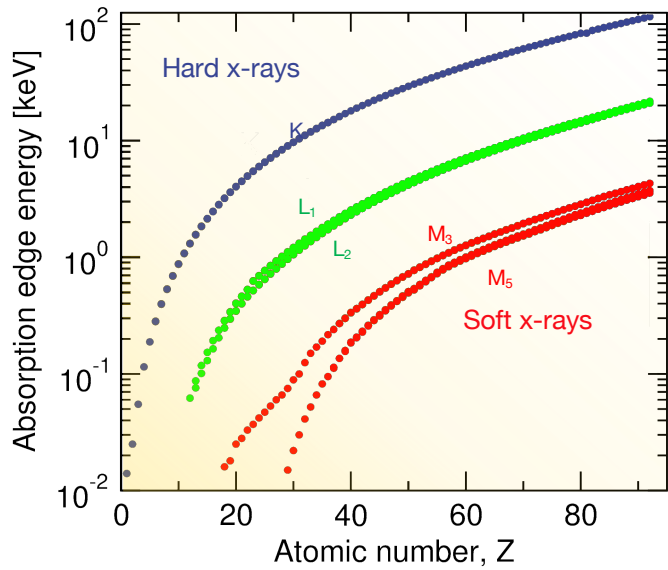

Why Neutrons: Magnetic scattering and isotope specific interaction

- magnetic structures, magnetic moment distributions, and magnetic excitations
- contrast variation with different isotopes for example H₂O vs. D₂O

