



# Materials Science at Large Scale Facilities

## Beamlines and detectors

Steven Van Petegem  
EPFL course MSE-435

# Table of contents

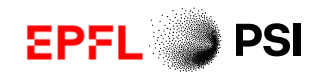

- **Neutron beam lines**
- Synchrotron beam lines
- X-ray detectors
- Neutron detectors

## Bragg's law

The Bragg law describes interference between rays elastically scattered off successive atomic planes, separated from one another by a distance  $d$ .

When the optical path difference between adjacent rays is an integer multiple  $m$  of the x-ray wavelength, interference is constructive, and a diffraction peak will be seen at that angle.

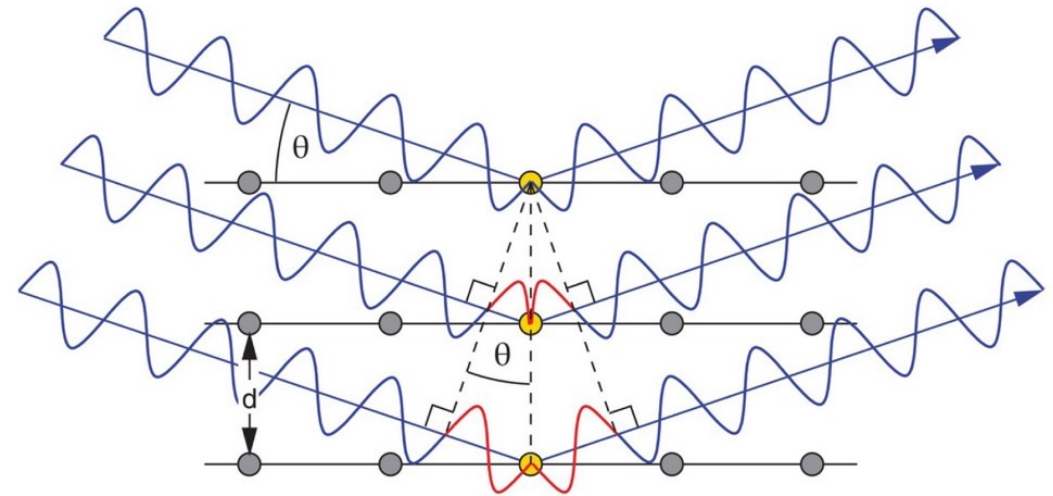

$$m\lambda = 2d \sin \theta$$

# Neutron beam lines

- Neutron sources are **large** compared to sample size ( $100\text{ cm}^2$  vs  $1\text{ cm}^2$ )
- Neutrons sources are **weak**
- Neutron beams are **divergent** (*beam divergence in the range of  $0.2^\circ$  to  $1^\circ$* )
- Neutron beams are **"polychromatic"** (*wide energy range, e.g. thermal range: 5-80 meV*)
- Neutron beams are **not polarized**

# Neutron beam lines

- We need to transport neutrons to the experimental area (guides)  
→ **Mirror & Super-Mirror** : Flux, divergence, neutrons with wavelengths in the right range
- We need to determine incident and scattered neutron directions  
→ **Collimator** : Angular resolution
- We need to select out unwanted neutrons  
→ **Filters**
- We need to determine incident and scattered wavelengths (Energies)  
→ **Crystal Monochromator** : Wavelength resolution (Energy resolution)
- We need also to polarize neutron beams  
→ **Crystal/ Super-Mirror/  $^3\text{He}$  spin filter** : Orientation of the neutron spin

# Neutron optics

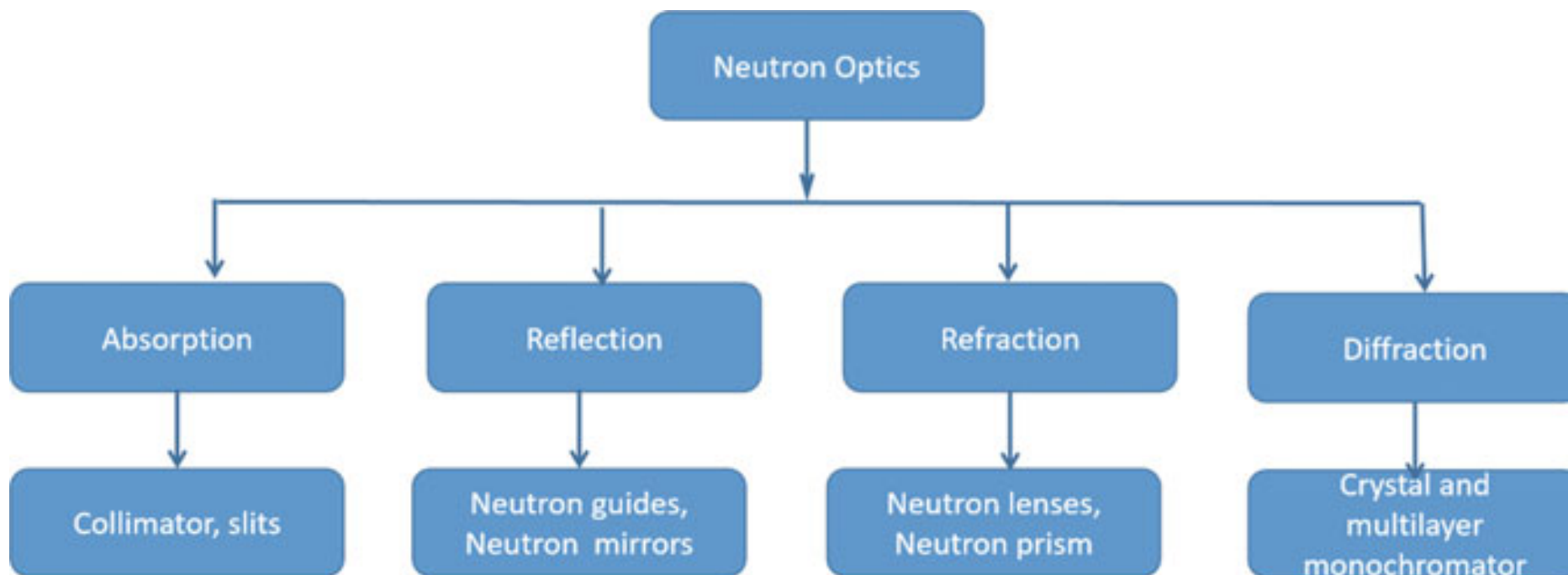

# Neutron mirrors

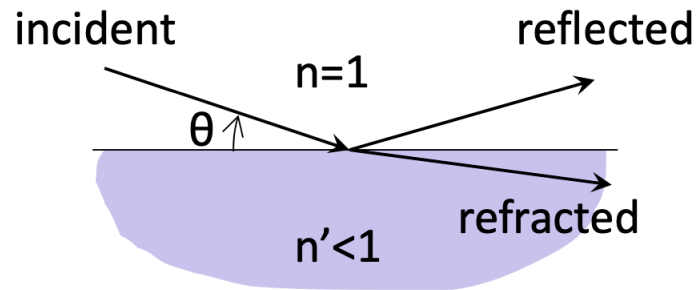

critical angle of total reflection  $\theta_c$

$$\left. \begin{aligned} \cos\theta_c &= n'/n = n' \\ n' &= 1 - \frac{N\lambda^2 b}{2\pi} \\ \cos\theta_c &\approx 1 - \theta_c^2/2 \end{aligned} \right\} \Rightarrow \theta_c = \lambda\sqrt{Nb/\pi}$$

Definition:  
 $Q = 4\pi \sin \theta / \lambda$

for natural Ni:  
 $\theta_c = \lambda[\text{\AA}] \times 0.1^\circ$   
 $Q_c = 0.0218 \text{ \AA}^{-1}$

# Neutron mirrors

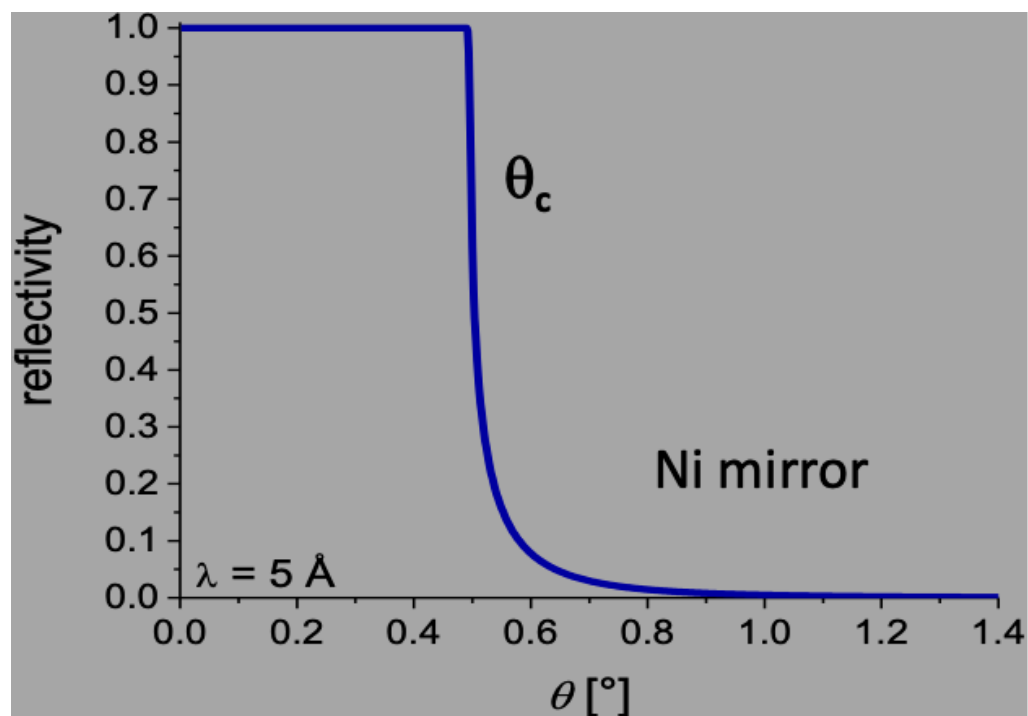

# Periodic multilayers

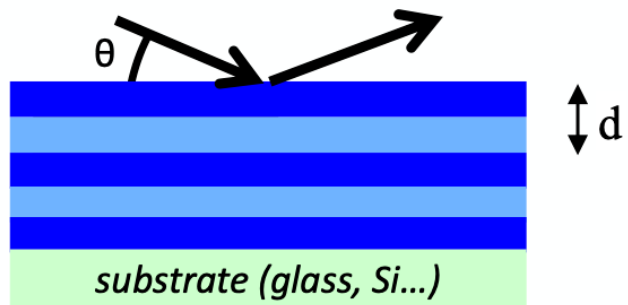

Total reflection for  $\theta < \theta_c$

Additional Bragg peak at  $\theta_B \approx \lambda / 2d$

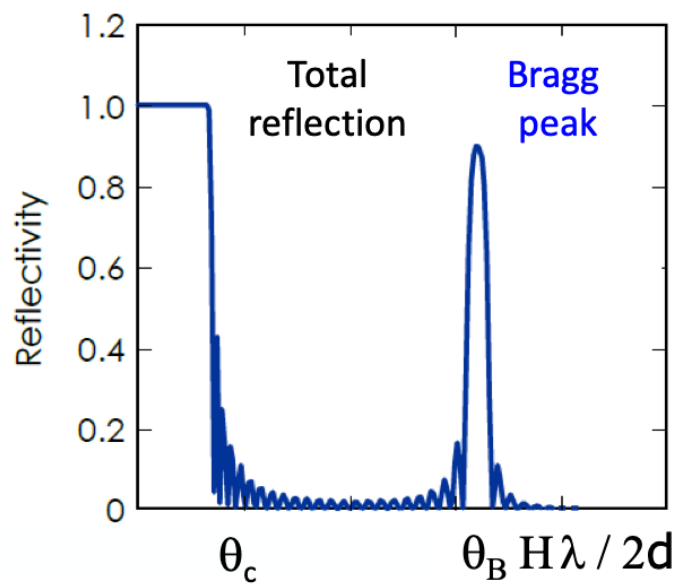

# Super-mirror

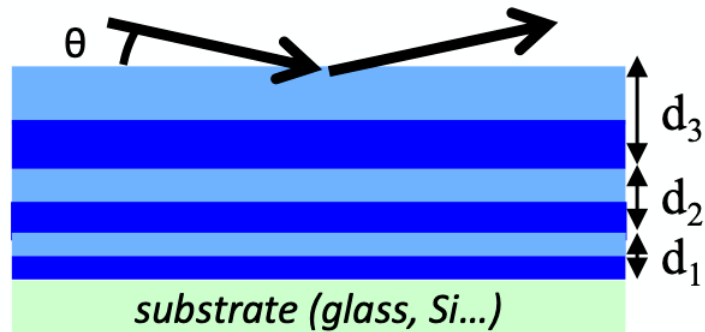

Sequence of bi-layers of variable thicknesses  $d$   
Total reflection for  $\theta < \theta_c$  + additional Bragg peaks

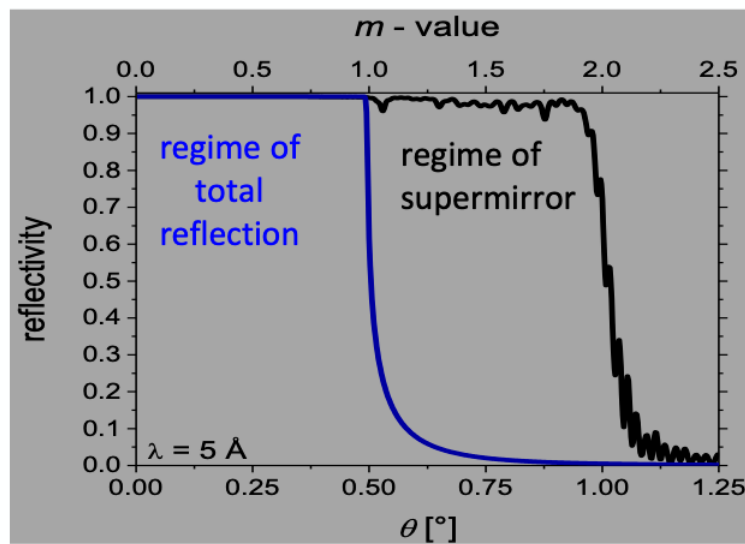

→ significant increase in critical angle

$$\theta_c = \lambda / 2d_{\min}$$

# Super-mirrors

- $m$  value super mirror:  $m = Q_c^{SM} / Q_c^{Ni}$
- Gain in Neutron flux  $\sim m^2$

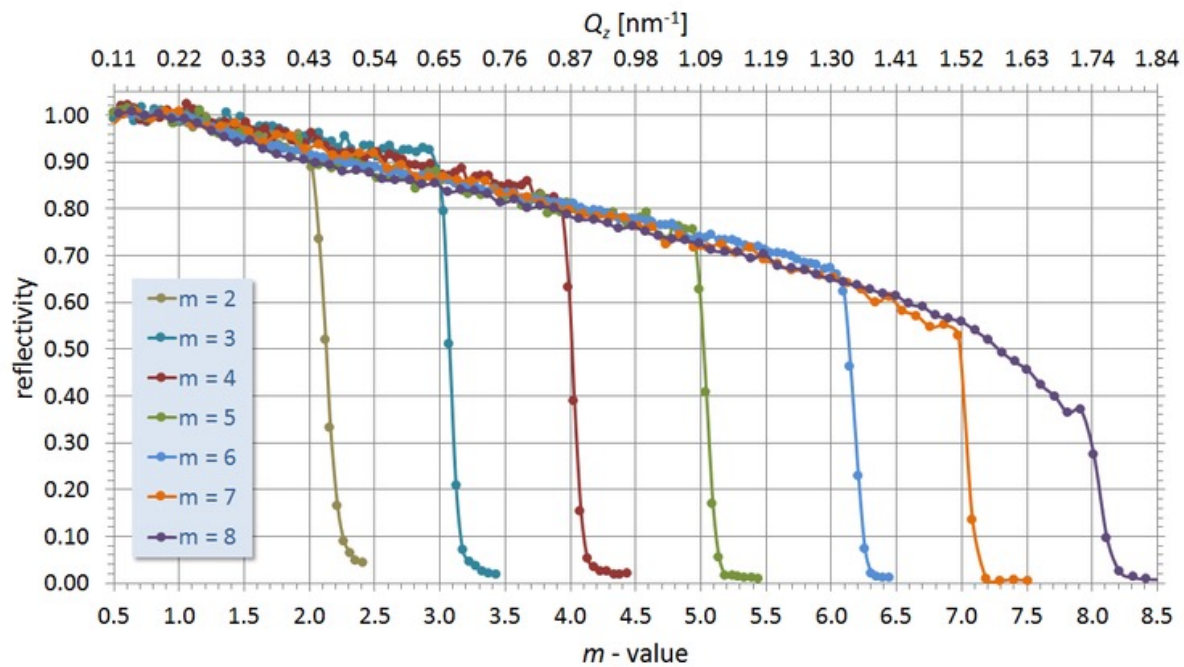

Ni/Ti super-mirror

## Ni/Ti super mirrors

Neutron guide can transport neutrons over long distances with limited loss



# Monochromator

- Use of single crystals to select a given wavelength band according to the Bragg's Law

$$n\lambda = 2d\sin(\theta)$$

- The relative bandwidth  $\Delta\lambda/\lambda$  is given for Gaussian distributions by:

$$\Delta\lambda/\lambda = (\alpha^2 + \beta^2)^{1/2} \cot(\theta_B)$$

- $\alpha$  : *divergence of the primary beam*
- $\beta$  : *full width at half maximum of the neutron “rocking curve” or neutron mosaic spread*

# Monochromator

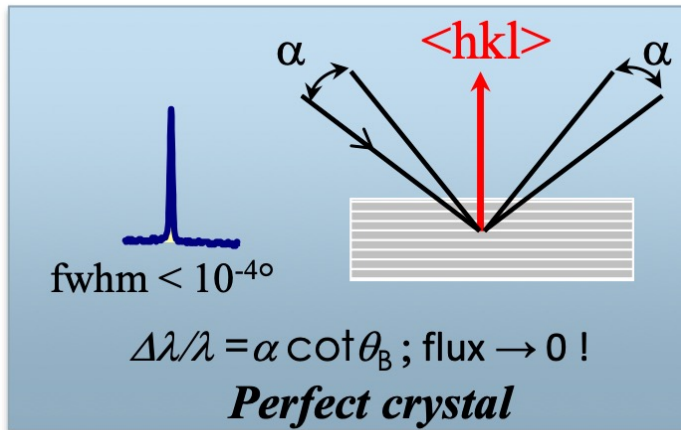

## Perfect crystal

- The reflection range of perfect crystals is in the order of  $0.001^\circ$ .
- Perfect crystals do not reflect efficiently neutrons from the source of divergence  $\alpha$ .
- Very high resolution but no intensity

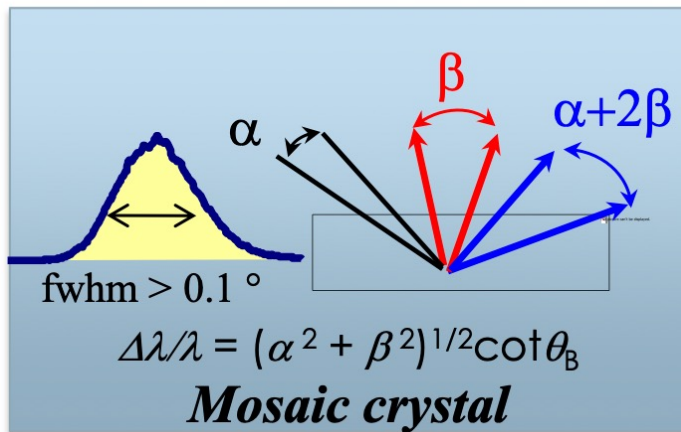

## Mosaic Crystal

- The reflection range of mosaic crystals is of the order of  $0.3^\circ$  even more....
- Mosaic crystals can reflect efficiently neutrons from the source of divergence  $\alpha$ , if  $\beta \sim \alpha$
- High intensity and reasonable resolution

## Velocity selector

A velocity selector is a mechanical device that allows only neutrons of certain wave-length or velocity to get transmitted through.

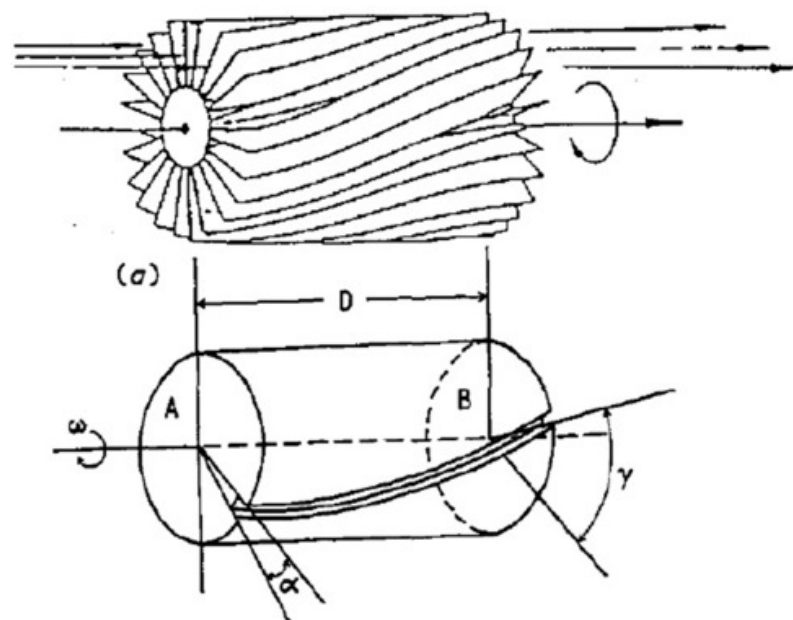

## Neutron choppers

Interrupt the neutron beam for well-defined durations

To convert continuous beam into a pulse one or to further shape an already pulsed beam

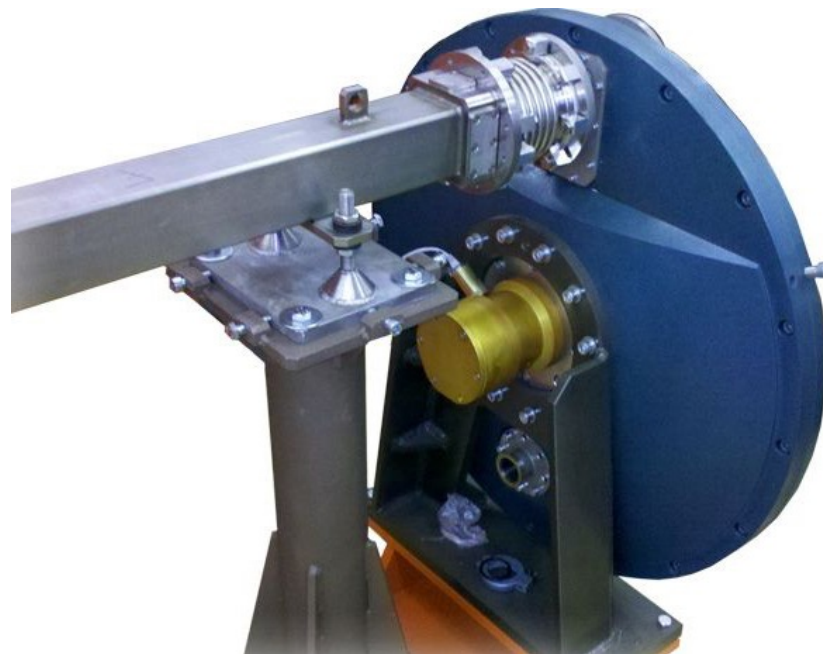
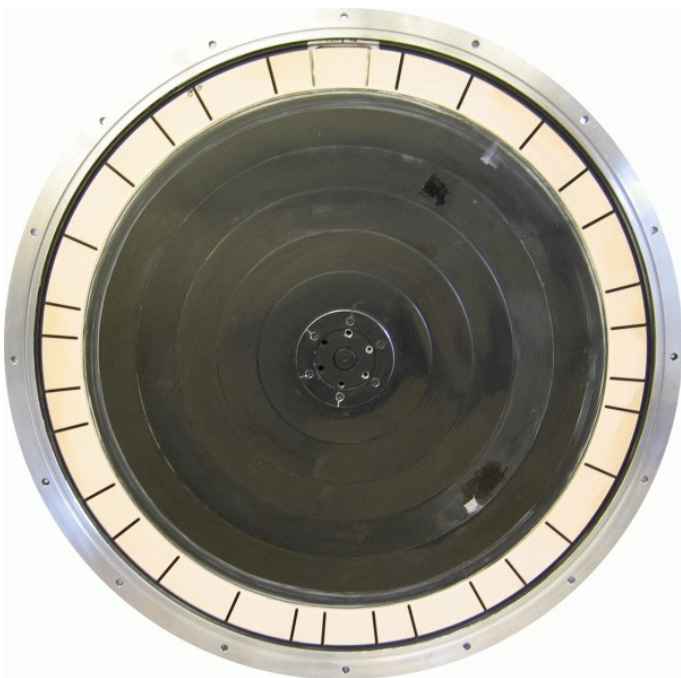

# Fermi chopper

- At a pulsed neutron source, the Fermi chopper is used for monochromatization of neutrons over a wide energy range up to the eV region and consists of a slit package rotating in synchronization with the production timing of pulsed neutrons.
- The Fermi chopper opens when it rotates to a position with the slit direction parallel to the incident neutron beam, and neutrons pass through the slit
- The slit-open time determines the energy resolution of the chopper spectrometer.

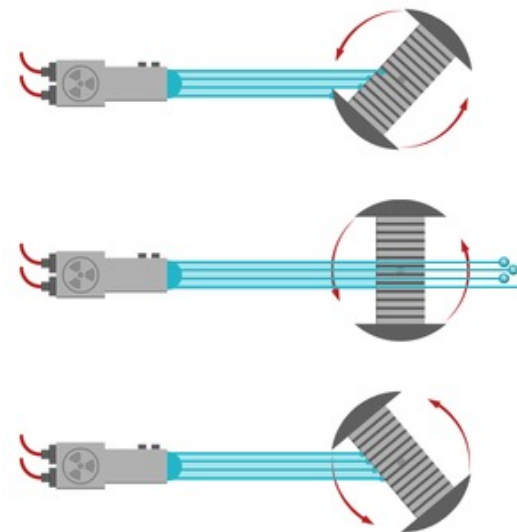
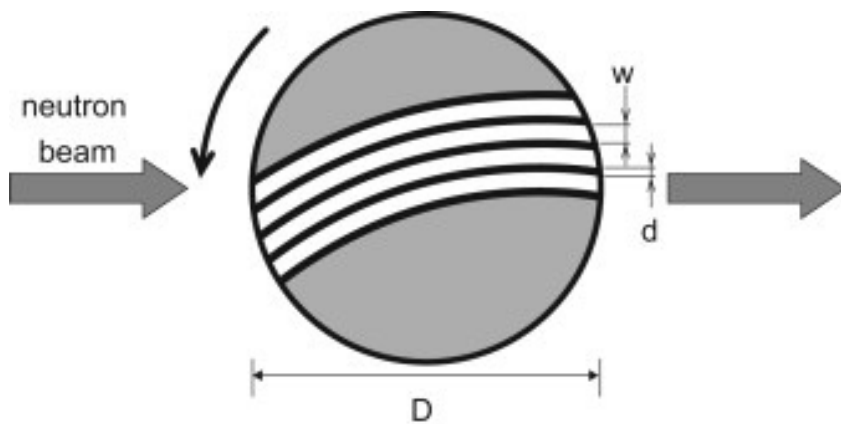

# Overview choppers

Feature	Velocity Selector	Disc Chopper	Fermi Chopper
<b>Principle</b>	Rotating cylinder with helical slits filters velocities	Rotating disc with radial slits pulses the beam	Rotating drum with absorbing slits chops beam by TOF
<b>Beam Output</b>	Continuous, quasi-monochromatic	Pulsed, polychromatic	Pulsed and energy-selected
<b>Energy Resolution</b>	Low ( $\Delta\lambda/\lambda \sim 10\%$ )	None	High ( $\Delta E/E \sim 1\%$ or better)
<b>Neutron Range</b>	Cold & thermal neutrons	Any range (timing only)	Thermal & epithermal neutrons
<b>Use Cases</b>	SANS, reflectometry	Pulse shaping, synchronization, frame overlap removal	Inelastic scattering, high-resolution TOF spectroscopy
<b>Output Nature</b>	Continuous monochromatic beam	Pulsed white beam	Pulsed monochromatic beam

# Focussing devices

Focusing devices are used to increase the neutron flux at the sample position. However, the increase of neutron flux implies a degradation of the angular resolution (Liouville's theorem). With other words:

- A **small spot** can be made at the expense of **large divergence**.
- A **collimated beam** (low divergence) can be created only if the source spot size is large.
- No device can magically create a **small, parallel, intense beam** from a larger, divergent, weak source

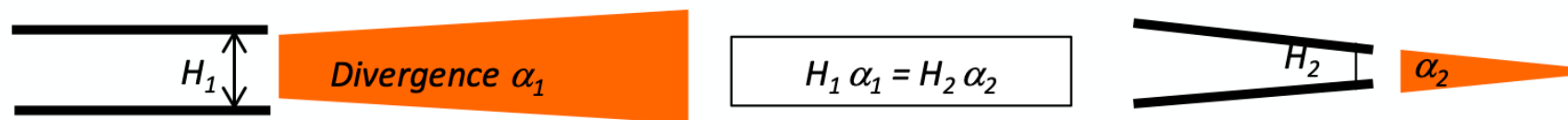

# Focussing devices

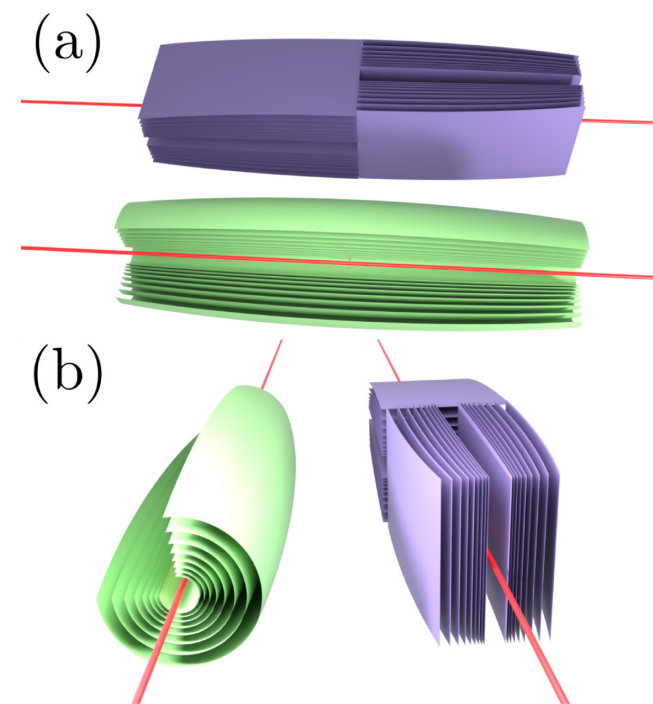
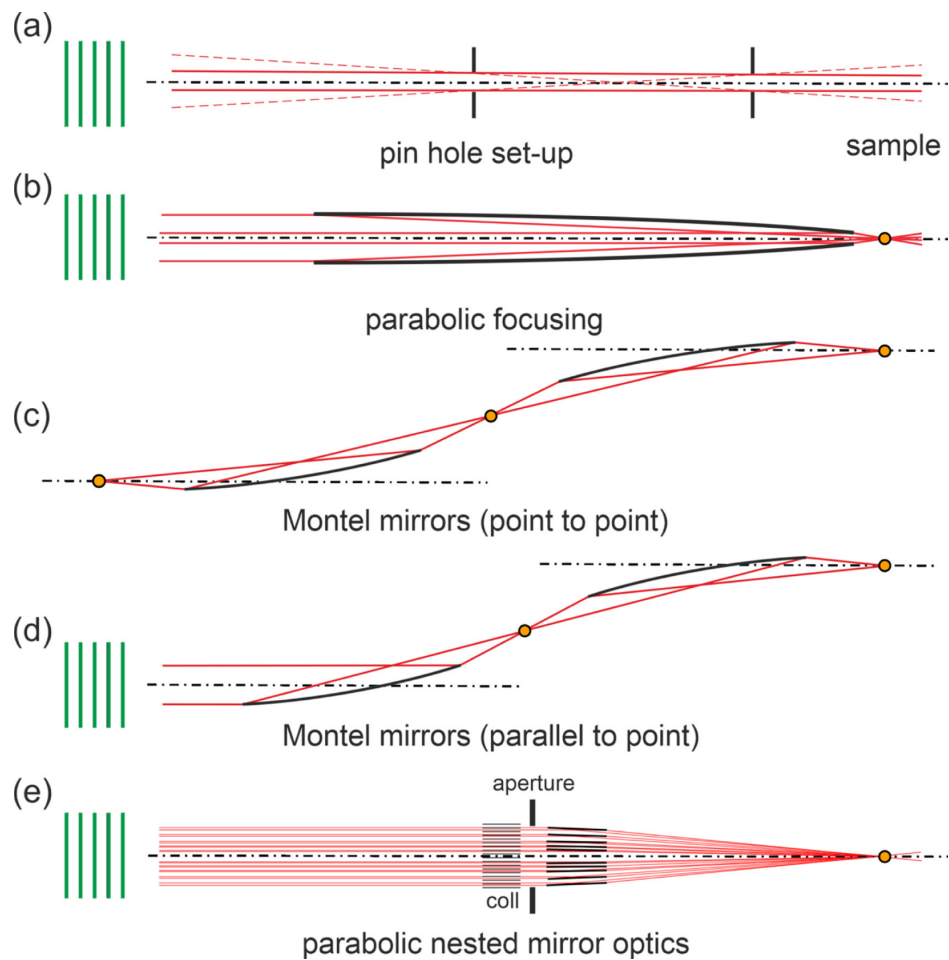

Double-planar (violet) and toroidal (green) elliptic nested mirror optics

## ***Nested mirror optics for neutron extraction, transport, and focusing***

Christoph Herb, Oliver Zimmer, Robert Georgii, Peter Böni, Nuclear Instruments and Methods in Physics Research Section A **1040** (2022) 167154

## Neutron filters

Reflect out unwanted neutrons with wavelength  $\lambda > \lambda_c = \theta / m \theta_c^{\text{Ni}}$

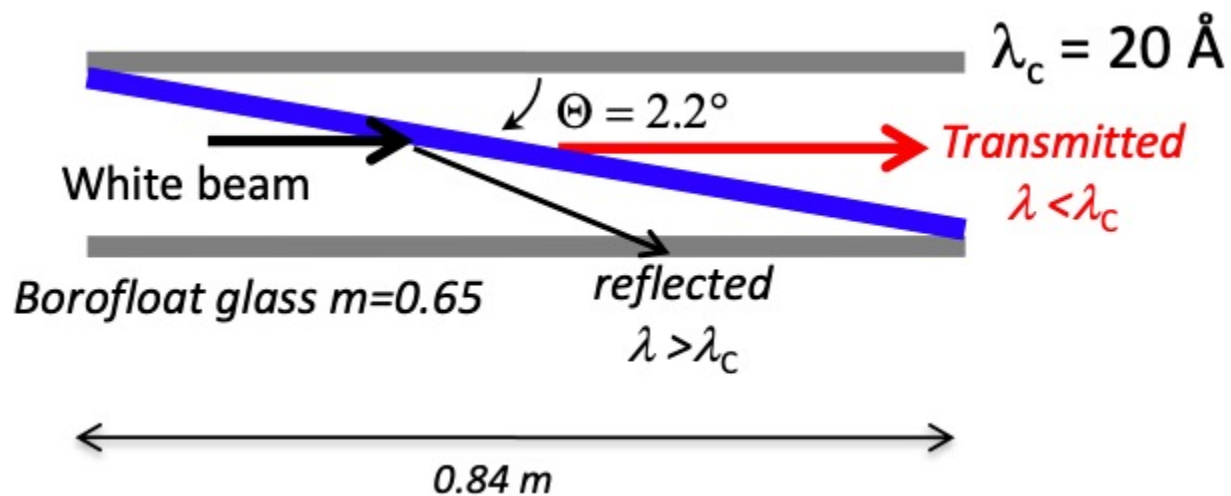

$m=1.1$  SM NiV/Ti on 0.5 cm thick Si substrate mounted at an angle  $\theta$  in a neutron guide

## Table of contents

- Neutron beam lines
- **Synchrotron beam lines**
- X-ray detectors
- Neutron detectors

# Synchrotron beam lines

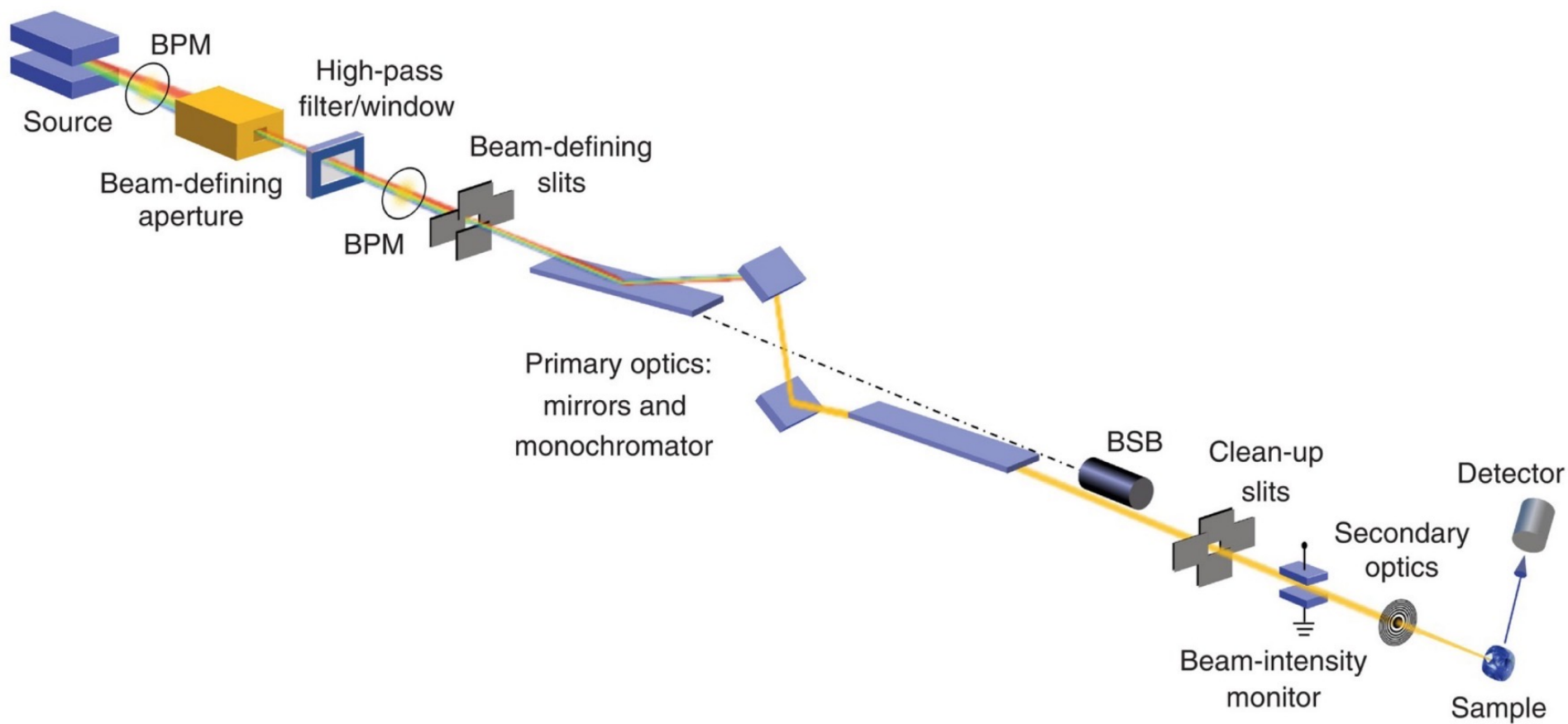

# Beam position monitor

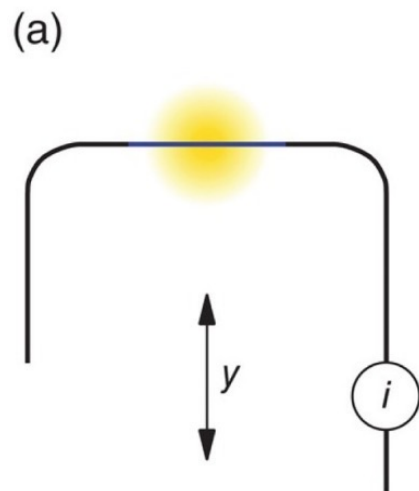

Thin wire scans across the beam to record its profile in one direction, by measuring the photocurrent induced by the x-rays

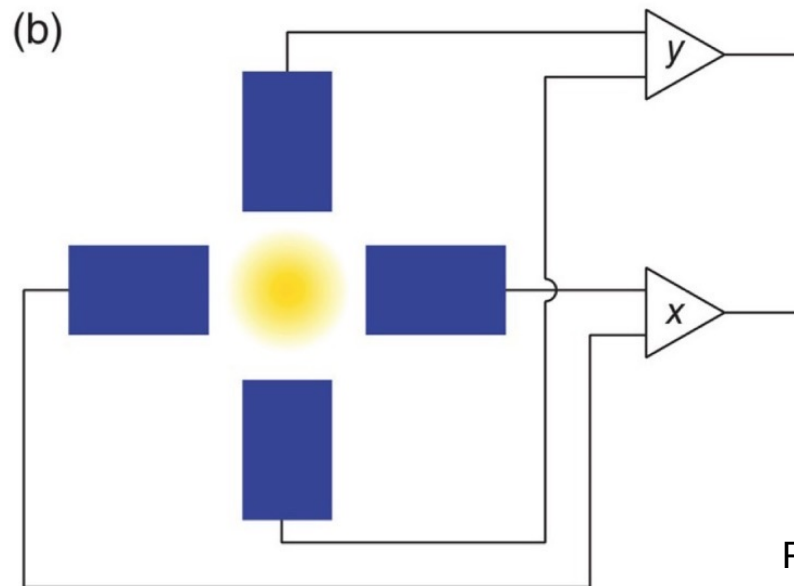

Four metallic blades intersect with the outer halo of the x-ray beam, thereby producing four independent photoelectron currents

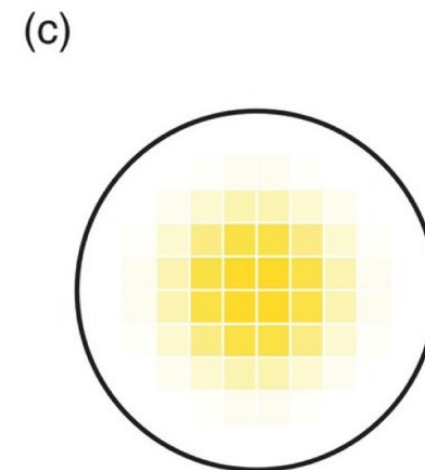

Photocurrents from an array of ultrathin metallic electrodes deposited on thin and transparent synthetic diamond discs

## Beam-defining primary apertures

The first component downstream of the source, these water-cooled apertures define the angular range to the beamline and often have a rectangular cone shape, in order to distribute the thermal load over a larger area. Because the outer parts of the synchrotron radiation contains lower-energy photons than the central cone, these apertures also act as high-pass filters.

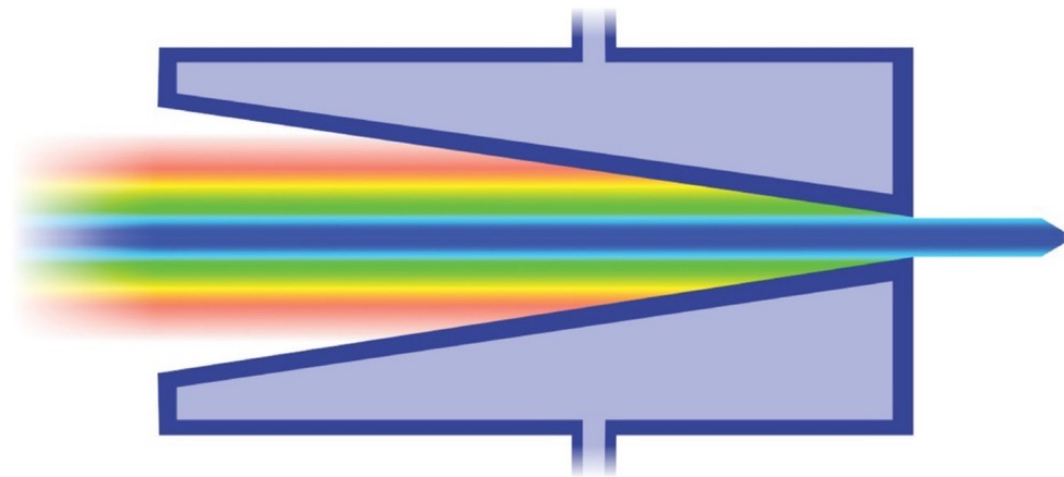

## Low-energy filters

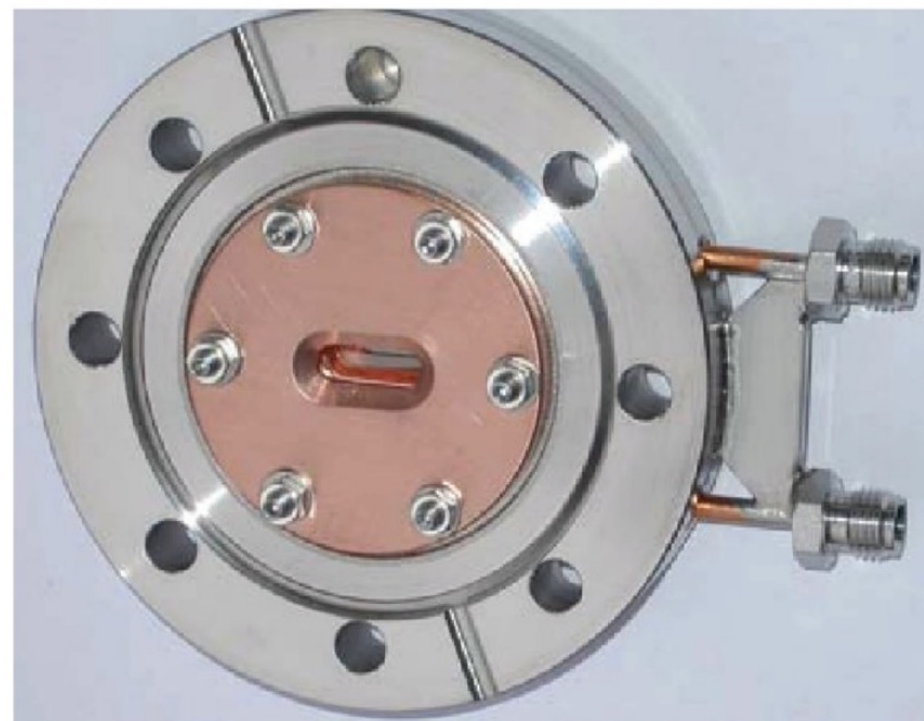
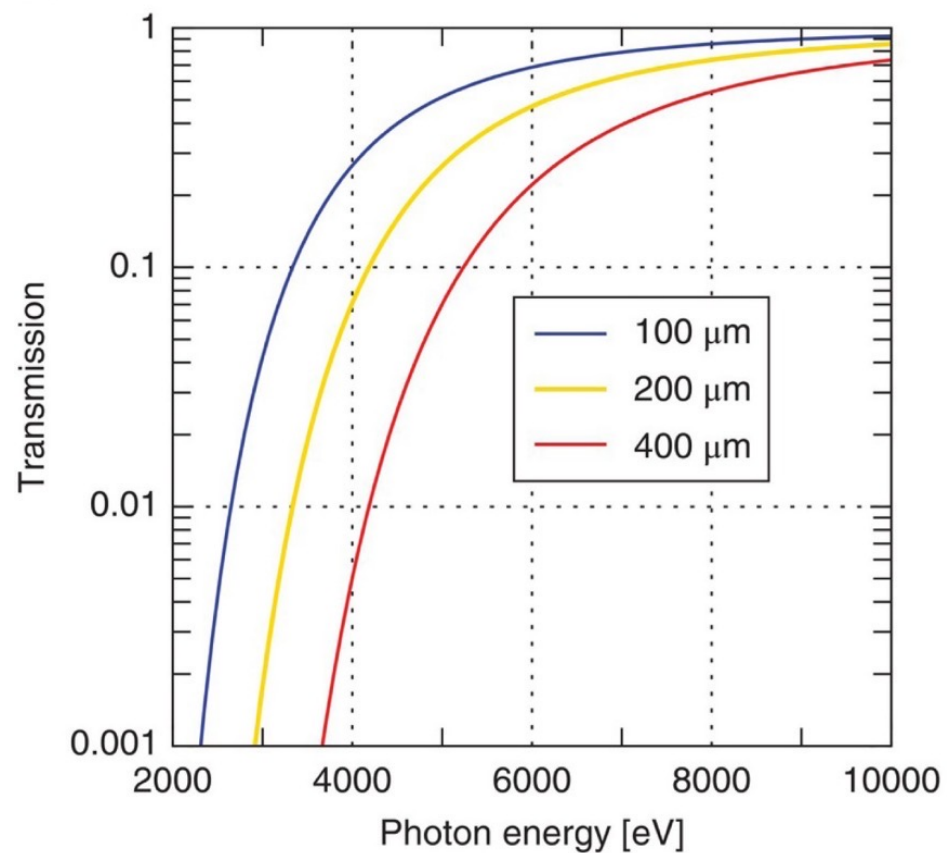

High-pass diamond front-end filters used to remove the low-energy component of the x-ray spectrum.

# X-ray optics

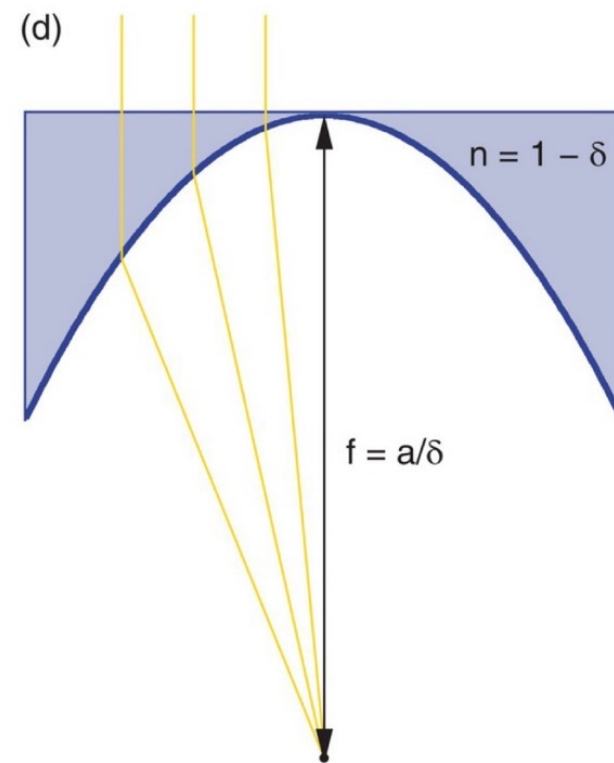
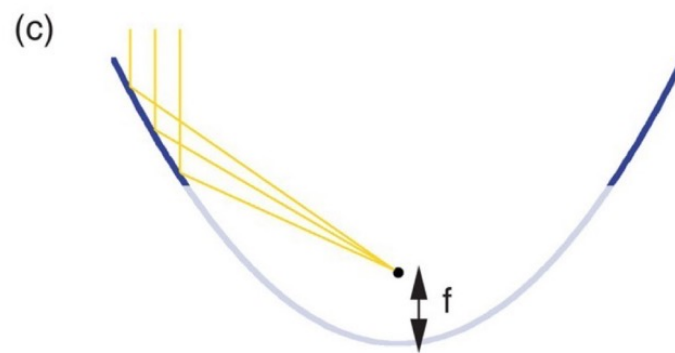
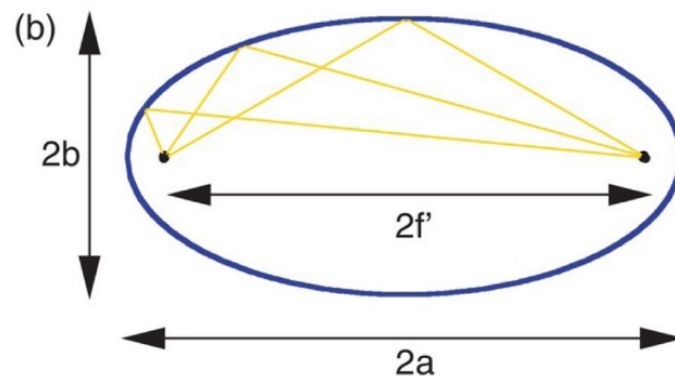
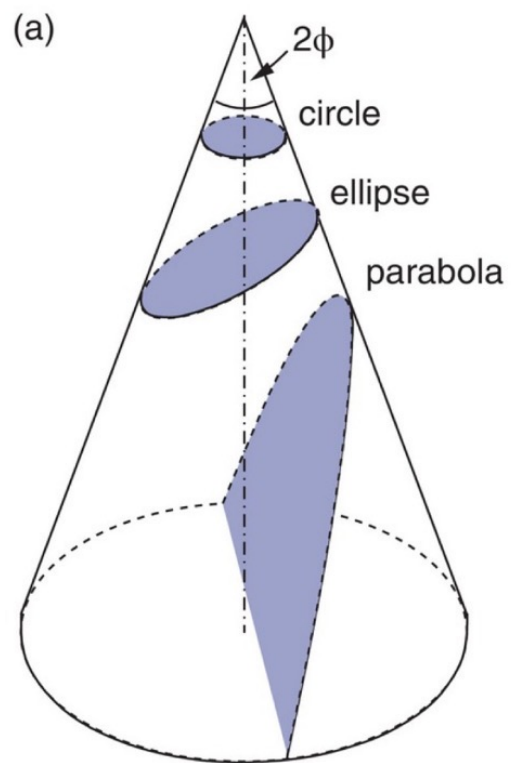

# X-ray optics

Schematic of an x-ray optical system, consisting of a double-crystal monochromator and two mirrors. Note that the second crystal of the DCM can also be bent to provide horizontal focussing.

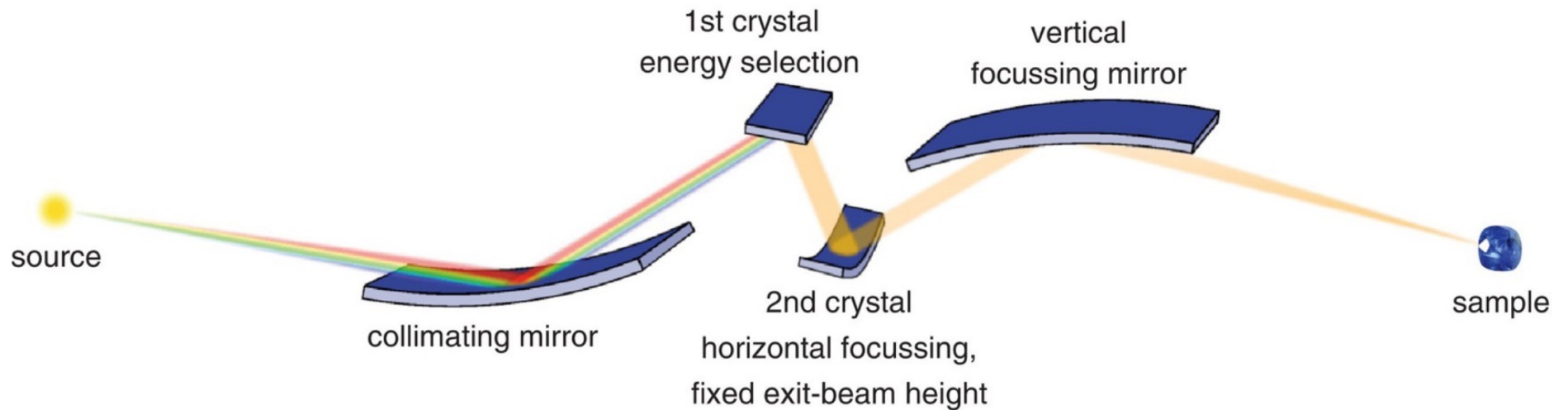

# Crystal monochromator

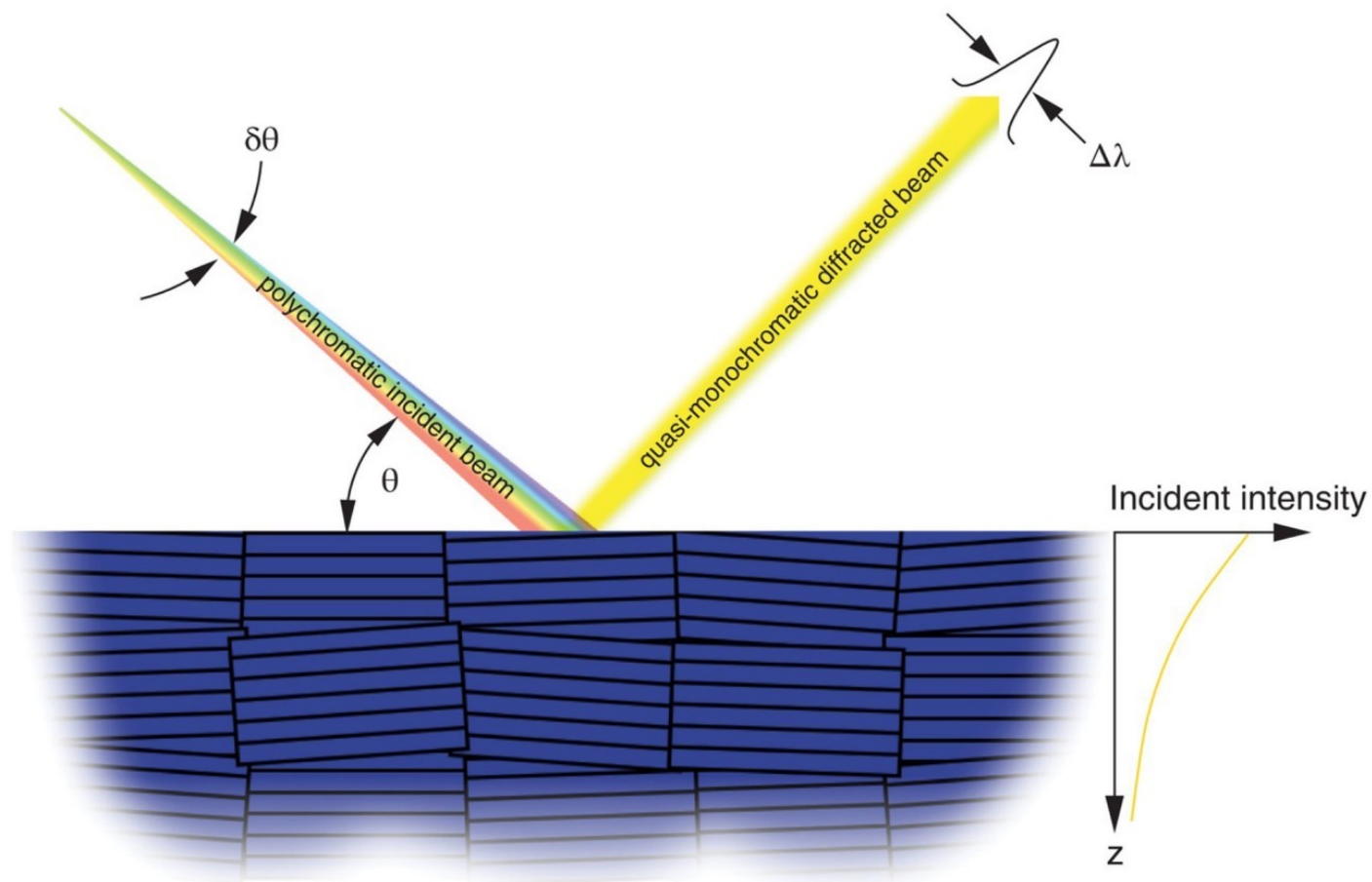

# Double crystal monochromator

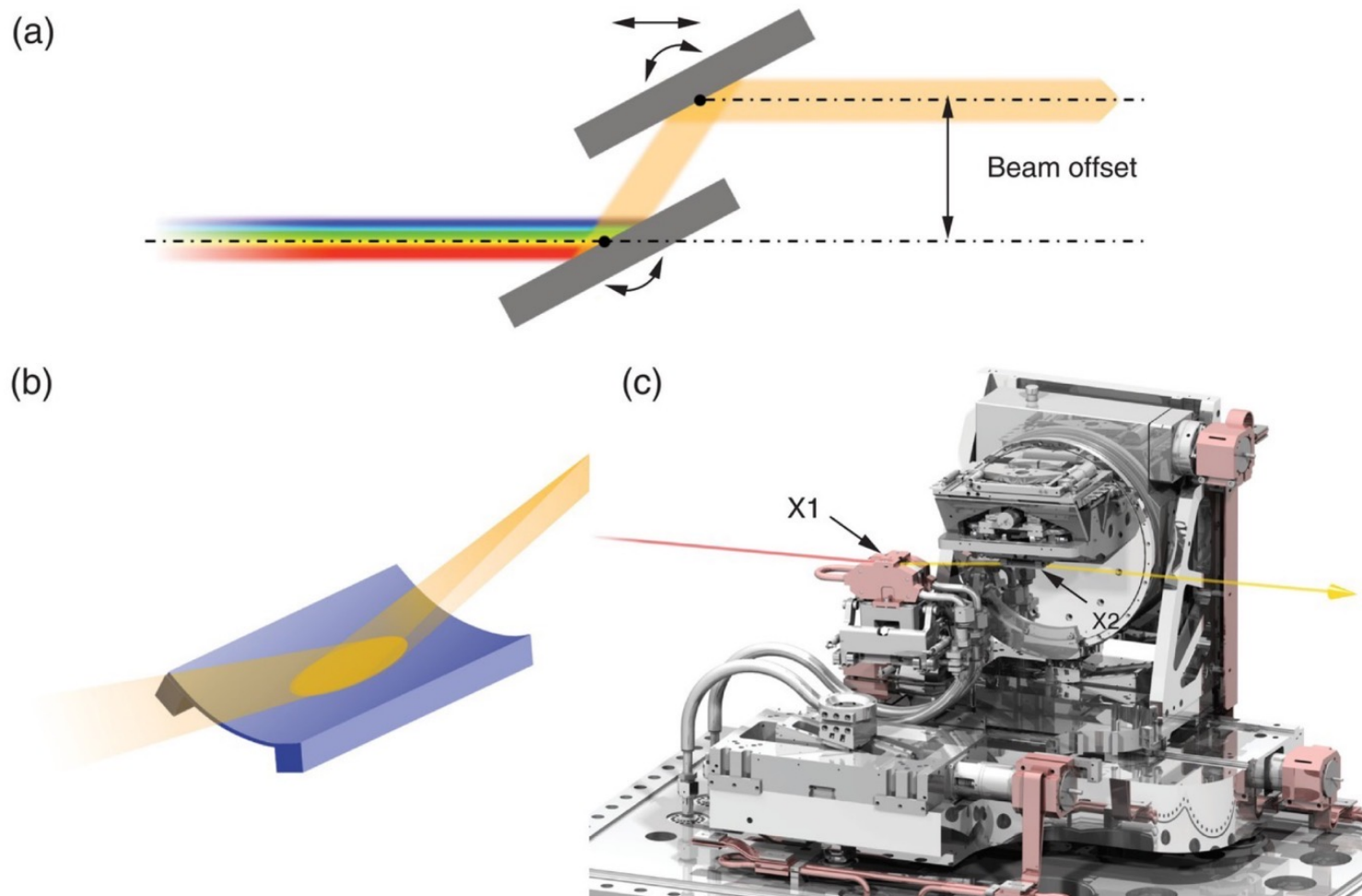

# Double crystal deflectors

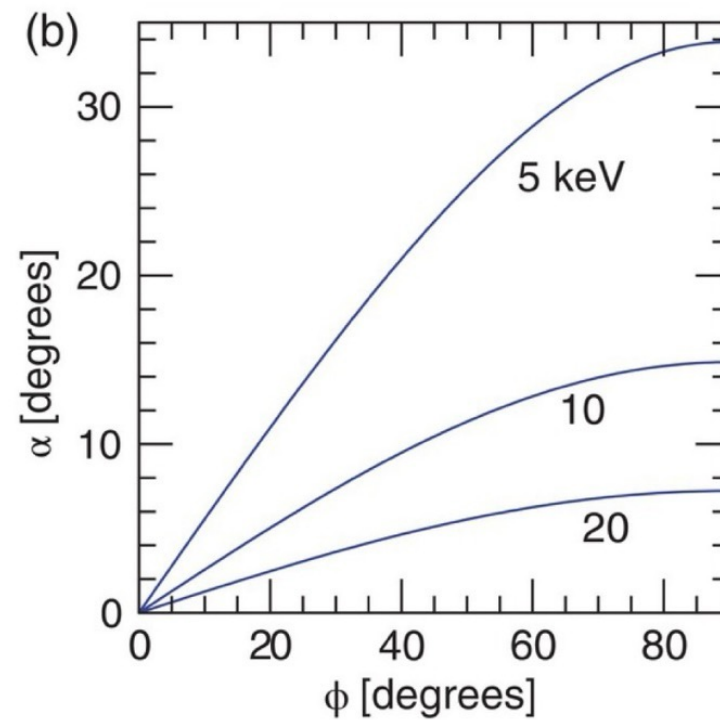
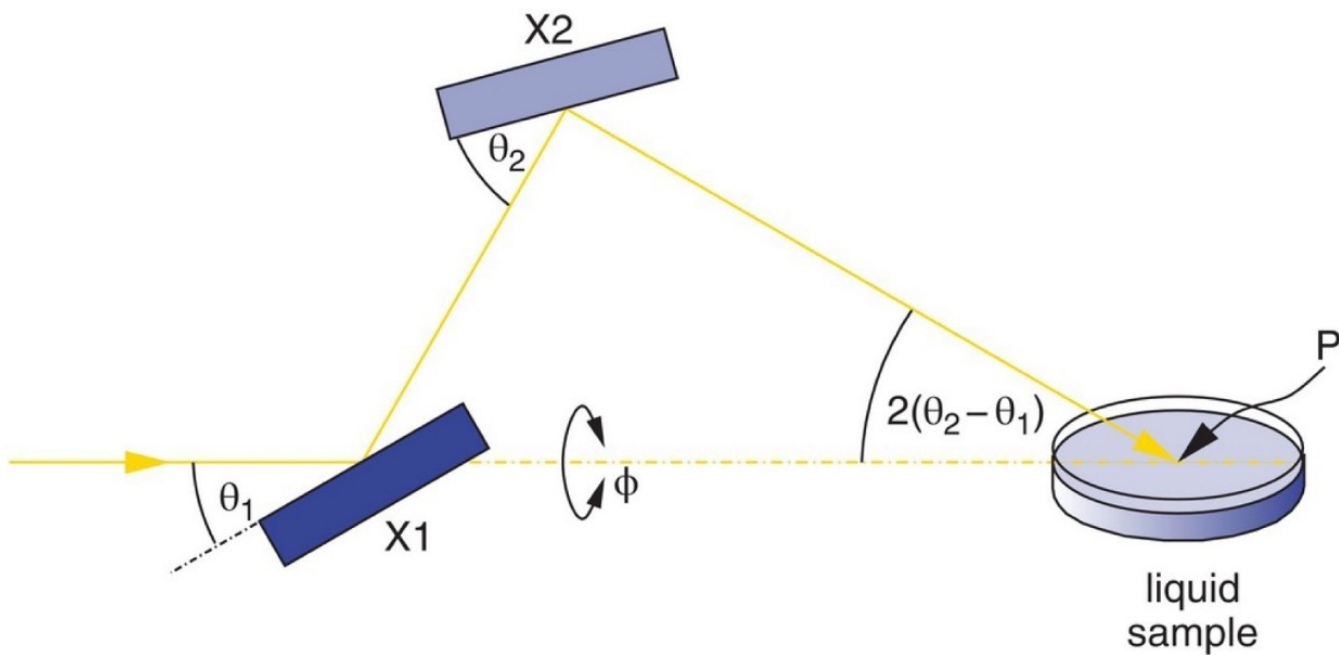

## Microfocus and nanofocus optics

- Micro- and nanofocus beams are formed by selecting a fraction of the primary focus using a pinhole, and demagnifying this ‘virtual source’ using secondary optics.
- Compound refractive lenses, tapered glass capillaries, Fresnel zone plates, multilayer Laue lenses, Kirkpatrick–Baez mirrors

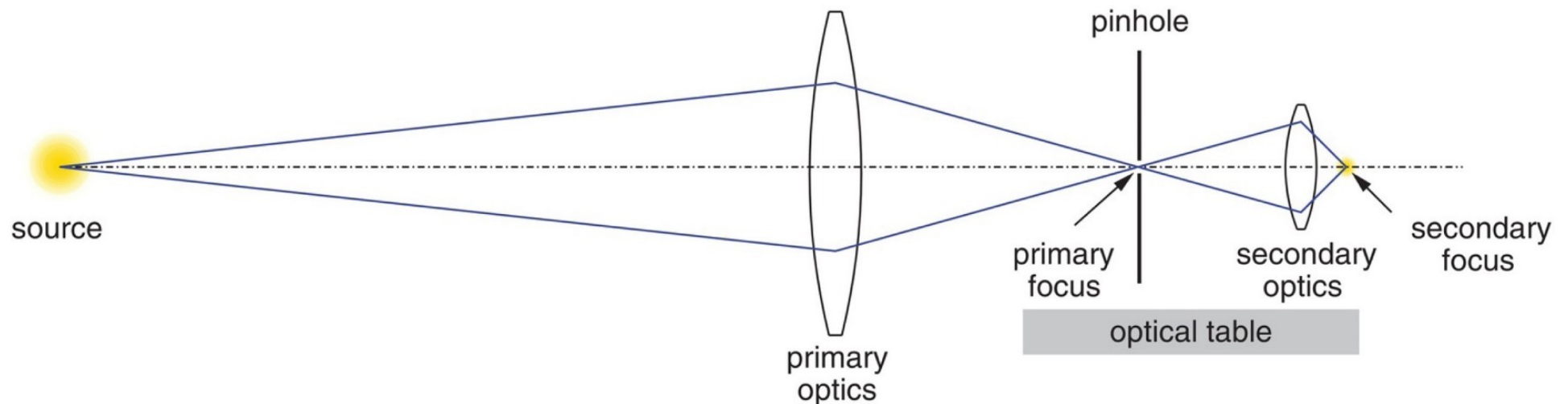

## Compound refractive lenses

- Compound refractive lenses. X-ray focussing elements can be constructed from high-transmission material drilled with arrays of holes, which act in much the same way as (very weak) cylindrical convex lenses do for visible light.
- Example: a Be lens consisting of an array of thirty 200  $\mu\text{m}$ -diameter holes has a focal length of approximately 73 cm at 12 keV.

$$f = R/2n_h\delta$$

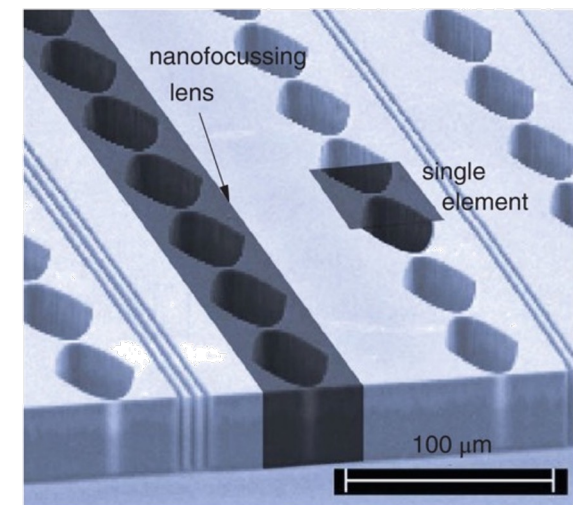
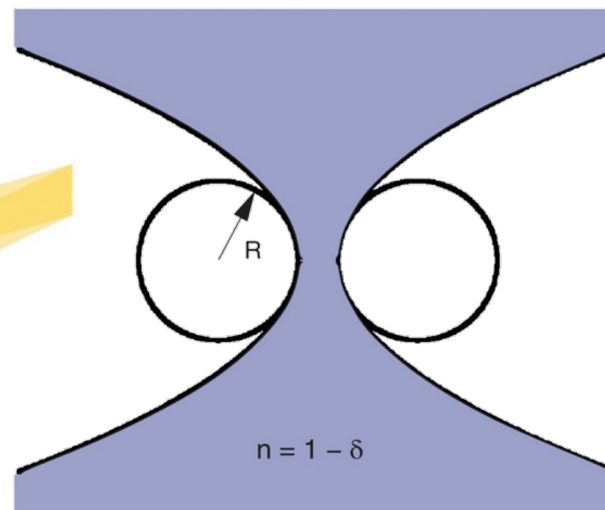
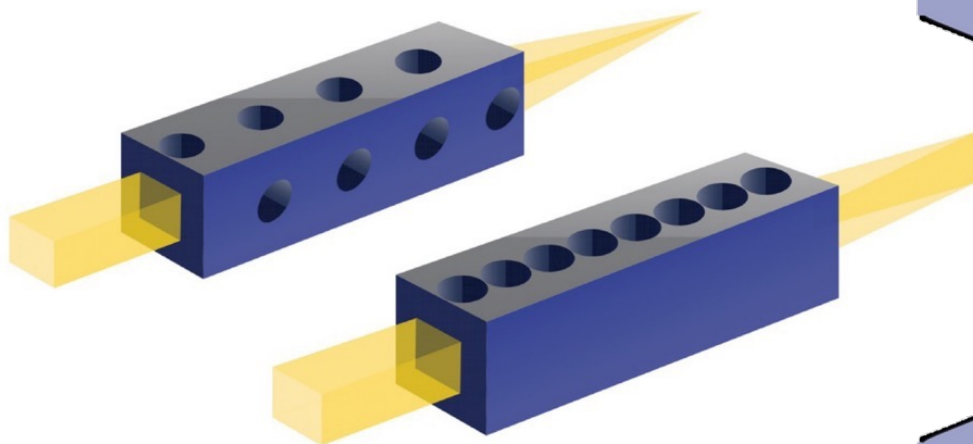

## Tapered glass capillaries

- Parallel rays entering the capillary will impinge on the surface at an angle  $\alpha$  and be deflected by an angle  $2\alpha$
- The  $n$ th reflection impinges on the surface at an angle  $(2n - 1)\alpha < \alpha_c$
- the focal length is independent of the photon energy,
- Needs to be placed very close to the sample

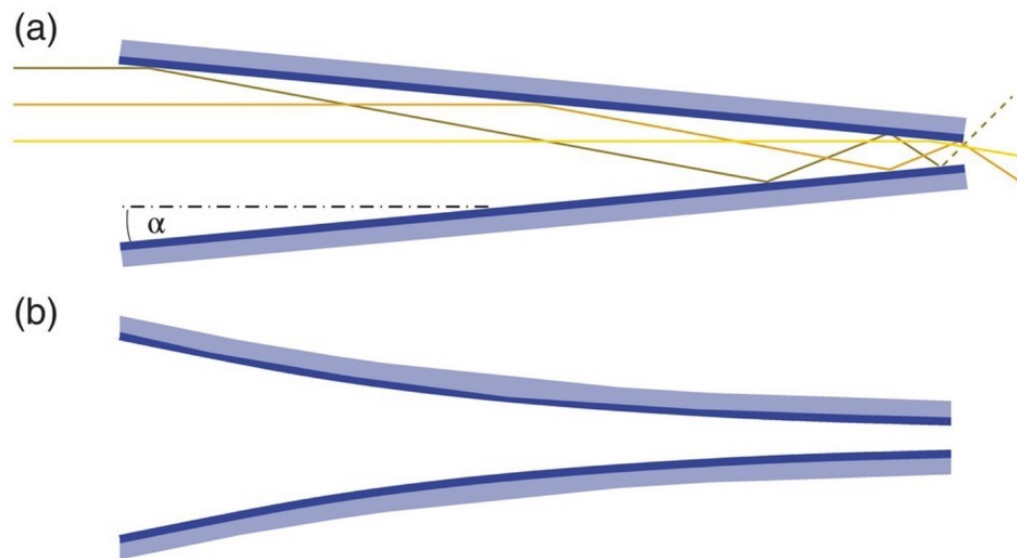

Schematics of (a) a conically tapered glass capillary lens and (b) a curved capillary lens. The inner surface of the capillary can be coated with a high-Z material to increase the critical angle for total external reflection.

# Fresnel Zone Plates

- Fresnel zone plates (FZPs) focus x-rays using diffraction
- electron-beam microlithography allows FZPs to be produced with outer rings well under 100 nm
- hard x-rays in the angstrom range can now be focussed down to just a few tens of nm

$$\sqrt{f^2 + r_{n+2}^2} - \sqrt{f^2 + r_n^2} = m\lambda$$
$$f = \frac{2r_N \Delta r_N}{\lambda} \quad \Delta r_N = \sqrt{\frac{\lambda f}{4N}}$$

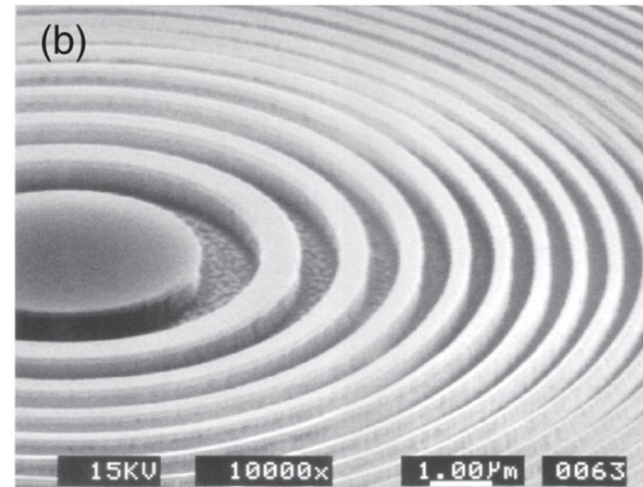
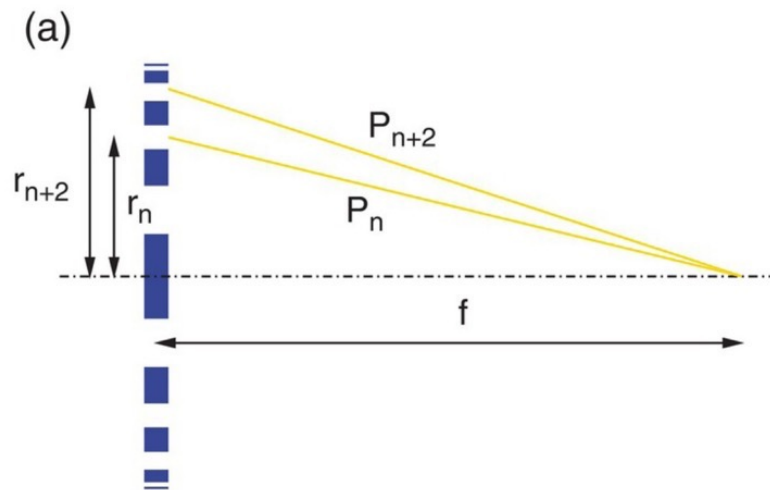

## Kirkpatrick–Baez mirrors

- By using two cylindrical mirrors in series, vertical and horizontal focussing can be achieved independently in the so-called ‘Kirkpatrick–Baez’ (KB) mirror configuration
- The focal lengths are independent of the photon energy
- Time-consuming to optimize spot size

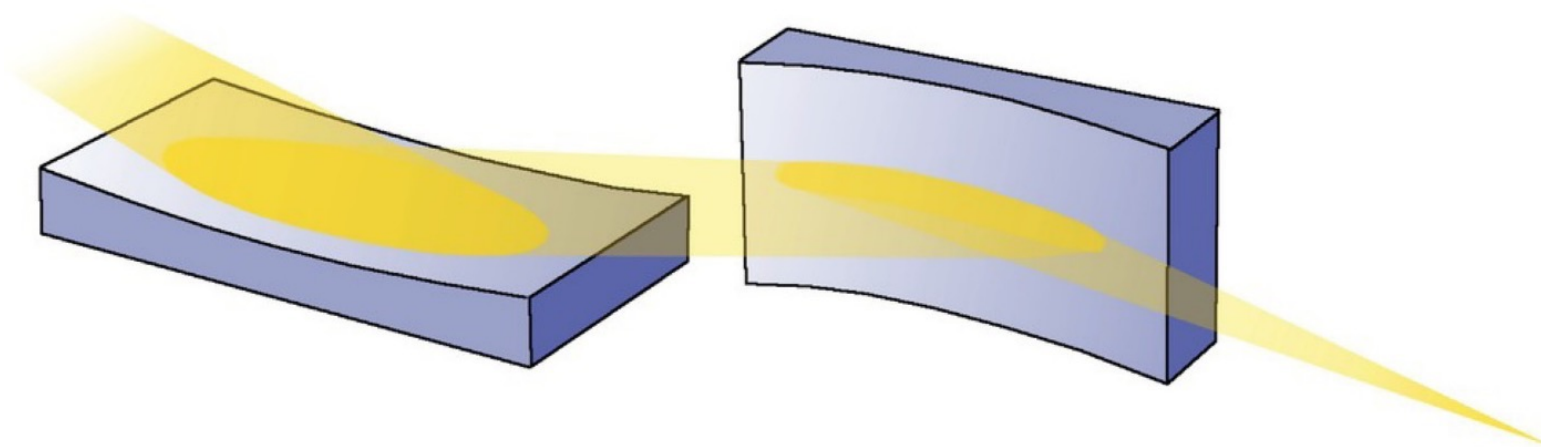

## Table of contents

- Neutron beam lines
- Synchrotron beam lines
- **X-ray detectors**
- Neutron detectors

# X-ray detectors

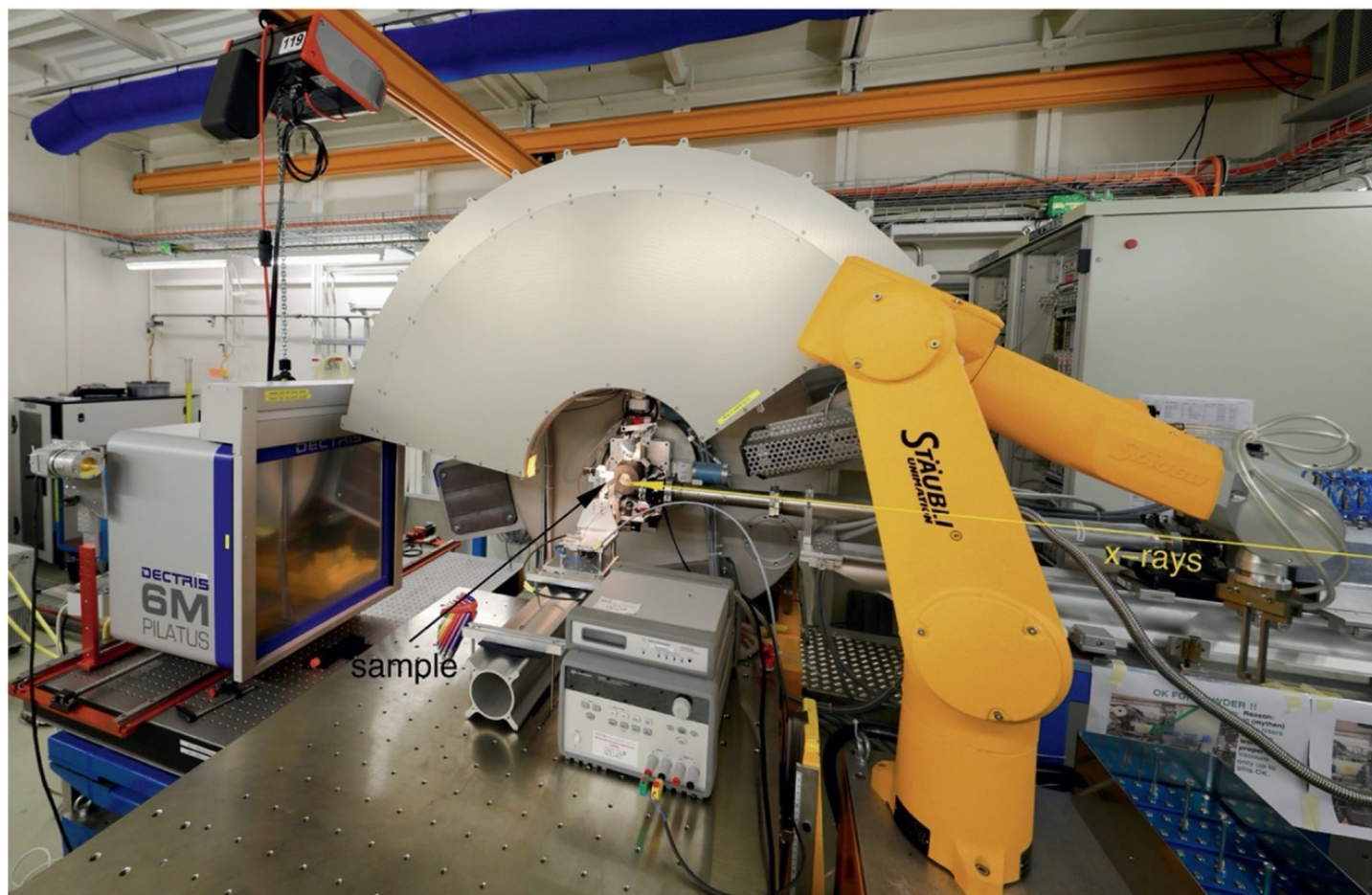

## Sources of noise

Any stochastic or random process composed of a series of discrete events, such as the arrival of x-ray photons on to a detector element, is subject to statistical, or ‘Poisson’, noise

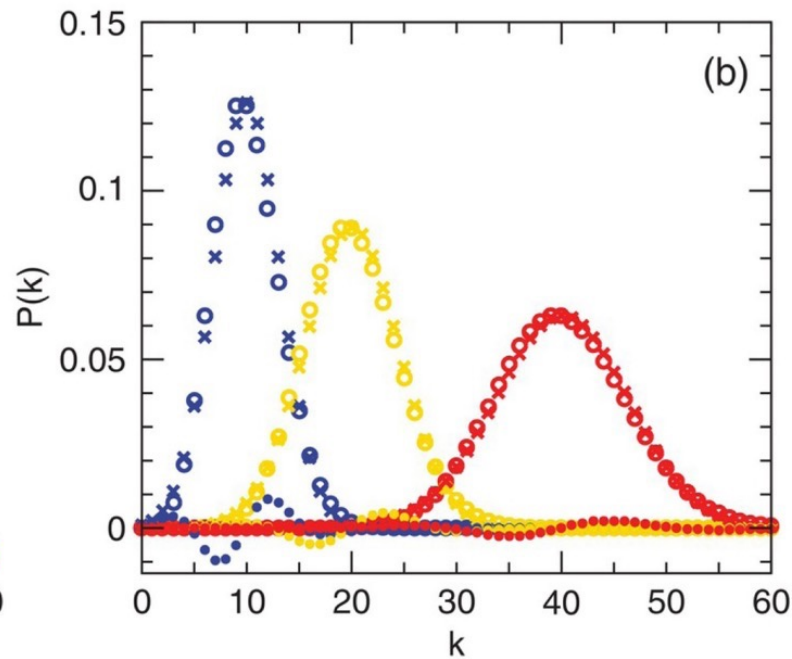
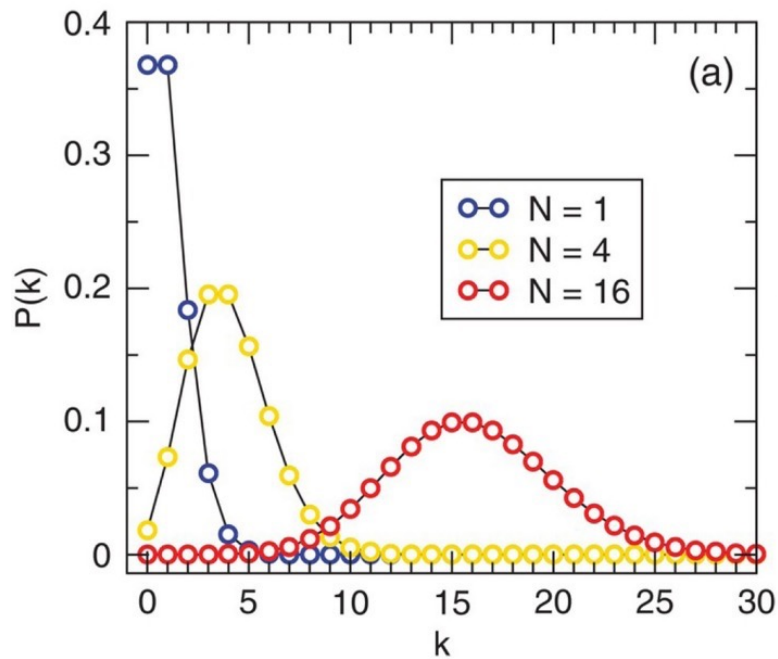

$$P(k) = \frac{e^{-N} N^k}{k!}.$$

$$P(k) \approx \frac{e^{-(k-N)^2/2N}}{(2\pi N)^{1/2}}.$$

Scatter  $\sim N^{1/2}$

To achieve a factor  $X$  improvement in the signal-to-noise ratio  $\Delta N/N$ , one must record  $X^2$  as long

## Sources of noise

### Dark noise

- Noise that is present, even in the absence of any photons
- Varies from pixel to pixel
- Dark images can be recorded to correct of it
- There exist detector with effectively zero dark noise

### Readout noise

- Only relevant for weak signal

# Point-spread function

- The point-spread function (PSF) describes the response of an imaging system to a point source
- A sharp signal can be smeared out due to various processes (finite pixel size, blooming, ...). This less sharp image is the convolution between the original object and the point-spread function

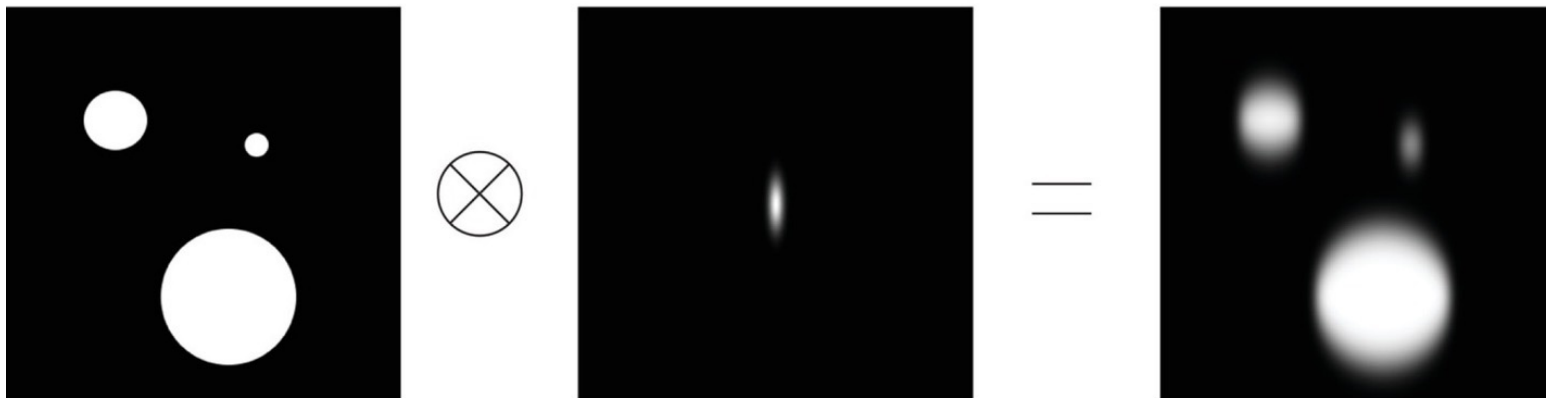

# Scintillator detectors

- Typical inorganic scintillator materials are salts or metal oxides doped with high-Z materials
- Photons produced by x-rays absorbed in the scintillator material strike photocathode material
- Electrons produced by the photoelectric effect are directed by a focussing electrode towards an array of electrodes.
- On striking a dynode, each electron produces several secondary electrons, which, in turn, are accelerated toward the next dynode, resulting in a cascade production of electrons.
- Accumulation of charge at the anode results in a sharp current pulse corresponding to the arrival of the original x-ray photon at the scintillator

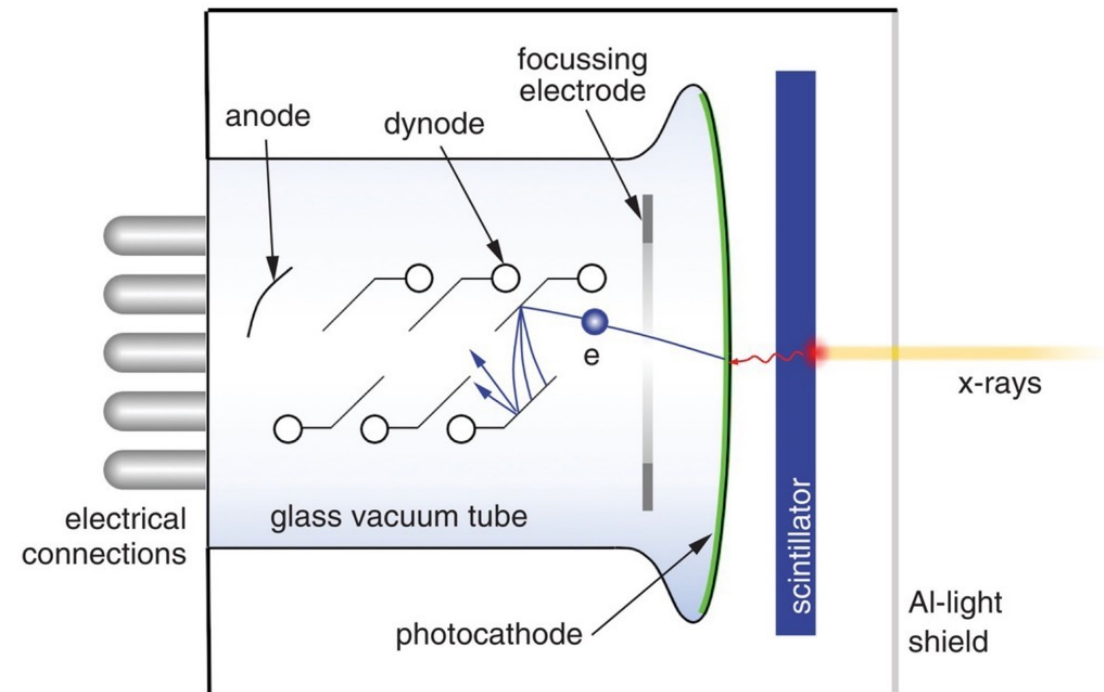

# Crystal analysers

- The angular resolution of a point detector is defined by the angles subtended by the irradiated sample volume and by the slit width at the detector.

$$\Delta\theta = \frac{S + W}{L}$$

- Many detectors, including scintillators, cannot distinguish x-rays with different energies.
- Solution: crystal analysers

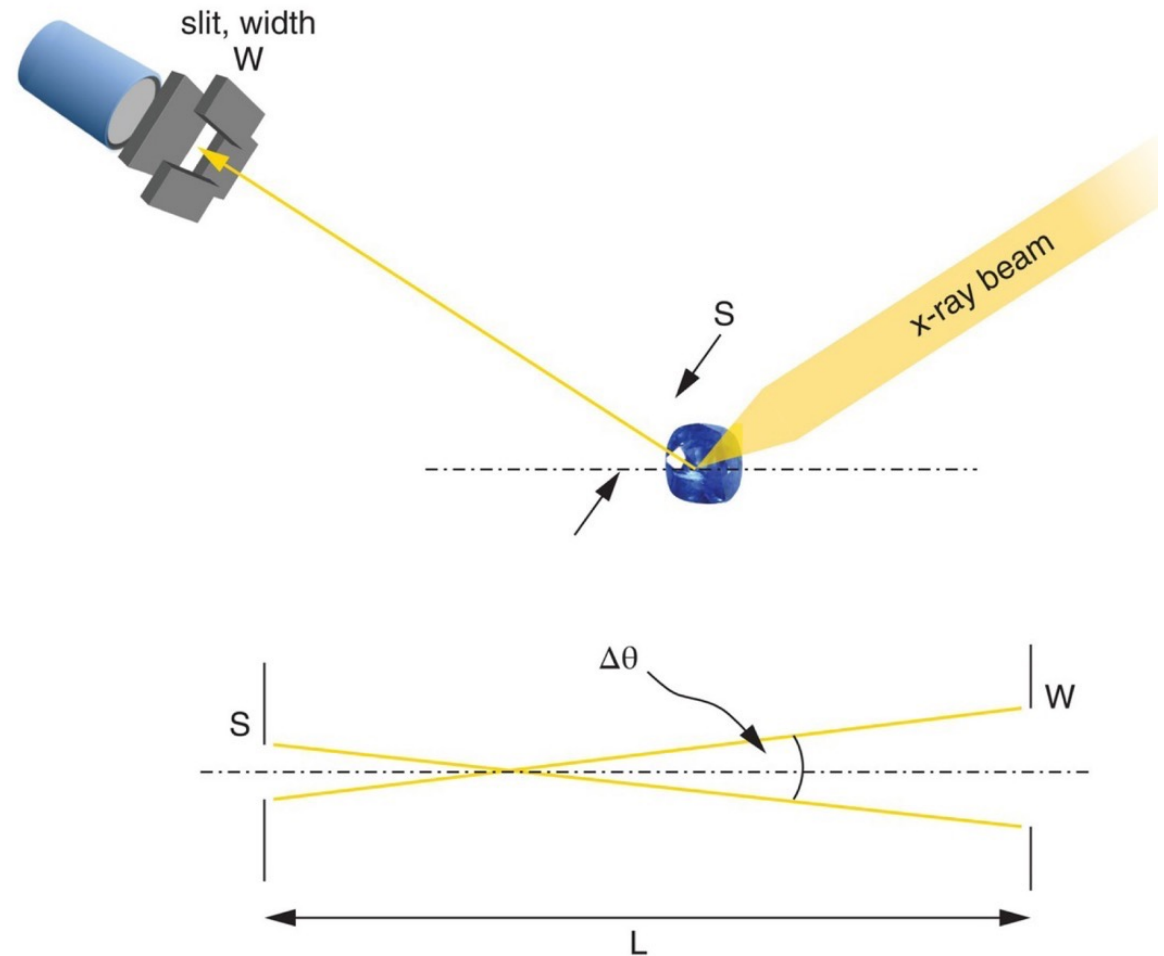

## Crystal analysers

The introduction of a single crystal in the detector system to select the monochromatic diffracted signal can improve the resolution by precisely defining the angle between the incoming beam and the diffracted signal. In addition, it suppresses lower-energy fluorescence signal.

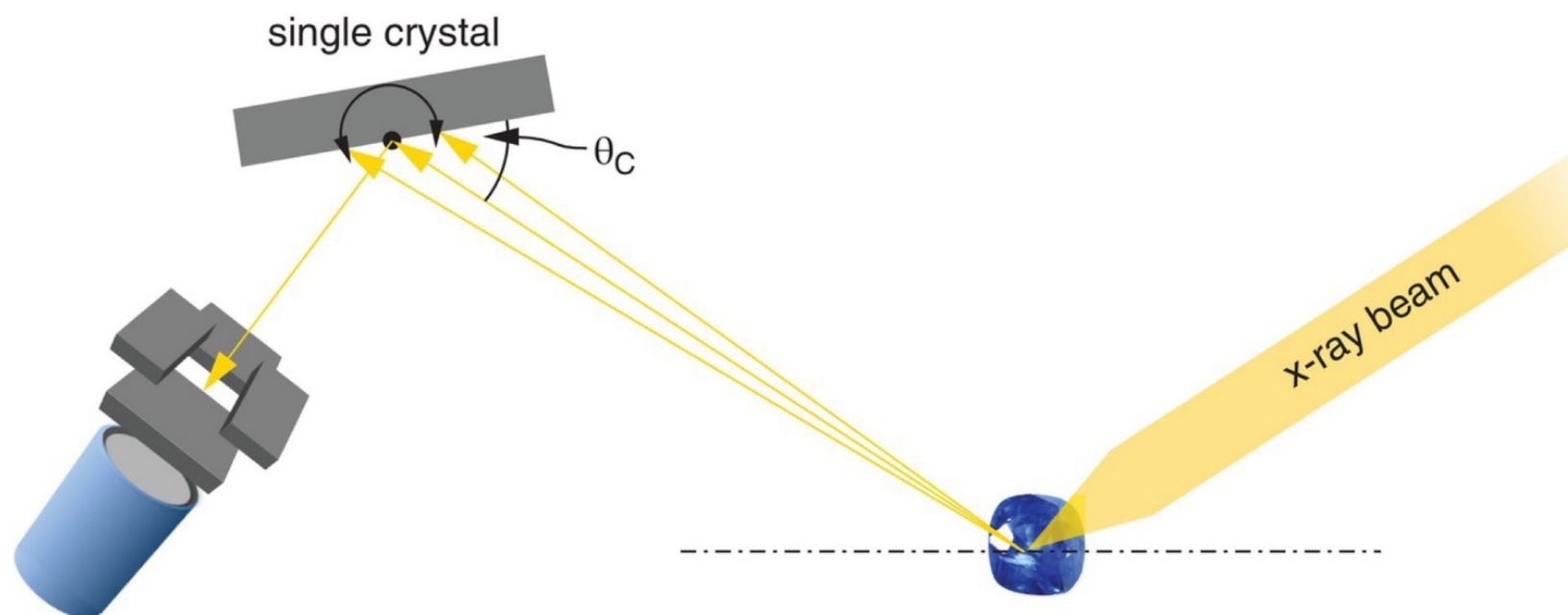

## Charge-coupled devices (CCD)

A CCD records images by converting photons of light into electrons

The electrons are temporarily accumulated in pixels on a photosensitive semiconductor chip.

At the end of an exposure, the accumulated charges are read off the chip

The signal is only read out after the exposure, CCDs are therefore termed *integrating* devices.

CCDs are used in conjunction with an overlayer of scintillator material typically a few tens of microns thick.

Advantage: small pixel sizes possible, well-established technology

Issues:

- Blooming causing streaks
- Dark noise
- Limited dynamic range

## Single photon counters

Electronics comprise of a preamplifier, a comparator, and a counter.

- The preamplifier amplifies the charge generated in the sensor
- The comparator produces a digital signal if the charge exceeds a predefined threshold
- Counter for digital storage

No readout noise, no dark noise

Can suppress x-rays with energies lower than a pre-defined value

Cannot be used for XFEL experiments – too slow

# Single photon counters

Further advantages:

- fast readout times (down to  $\mu\text{s}$  range)
- High dynamic range
- a high detector quantum efficiency
- Low dead time  $\tau$

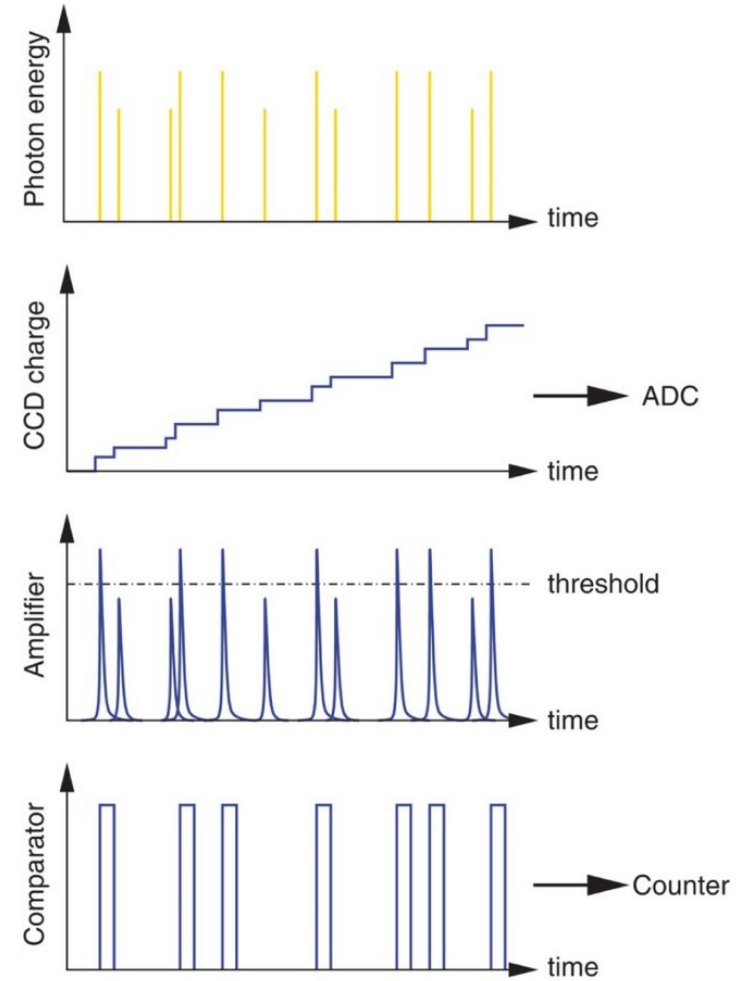
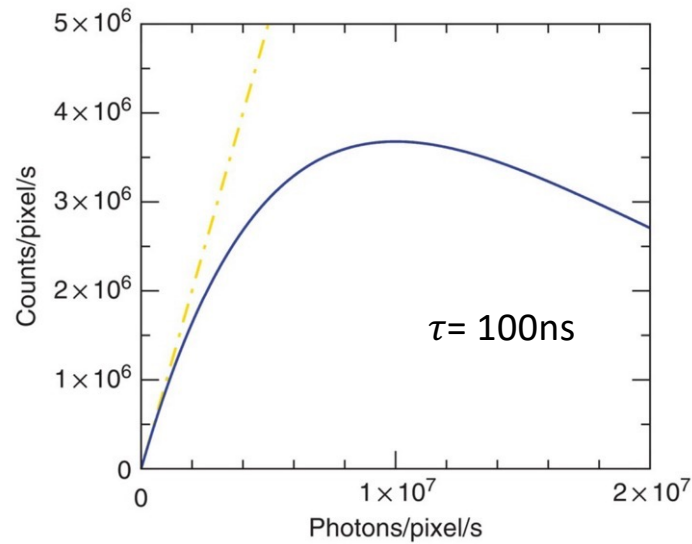

## Single photon counter

- Custom-made vacuum-compatible Pilatus 12M detector for the I23 low-energy macromolecular crystallography beamline at the Diamond Light Source, UK.
- The detector is composed of  $5 \times 24$  modules, each module containing approximately 100'000 pixels.
- The detector covers an angular range of 200 degrees



# Energy dispersive detectors

## Solid state detector

- Si(Li) or Ge technology
- Upon interaction with an x-ray photon, electron-hole pairs are created that drift in an applied high electric field.
- The charge is collected in a manner similar to the charging of a capacitor
- The voltage increment due to the collected charge is proportional to the photon energy

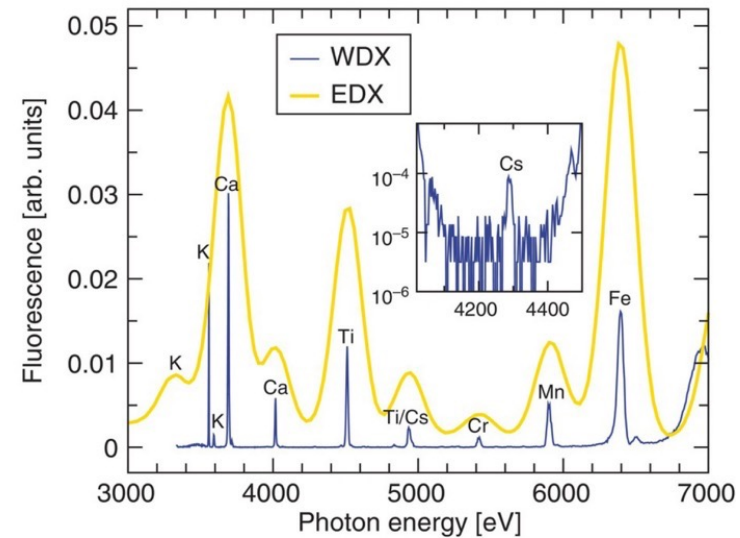
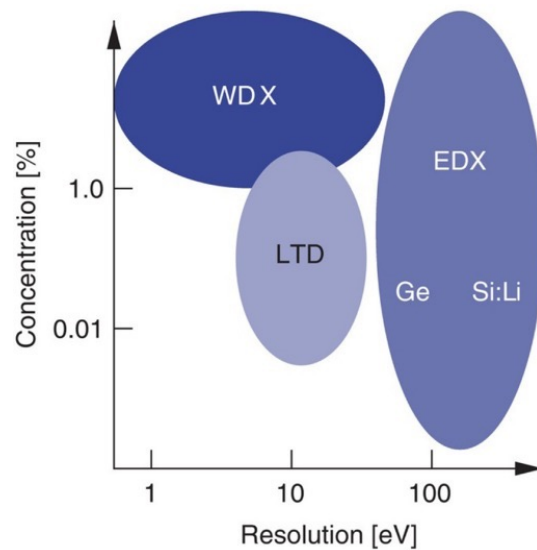

# Streak camera

- 2D image with one coordinate corresponds to time and the orthogonal axis to space
- Time resolutions down to 250 fs

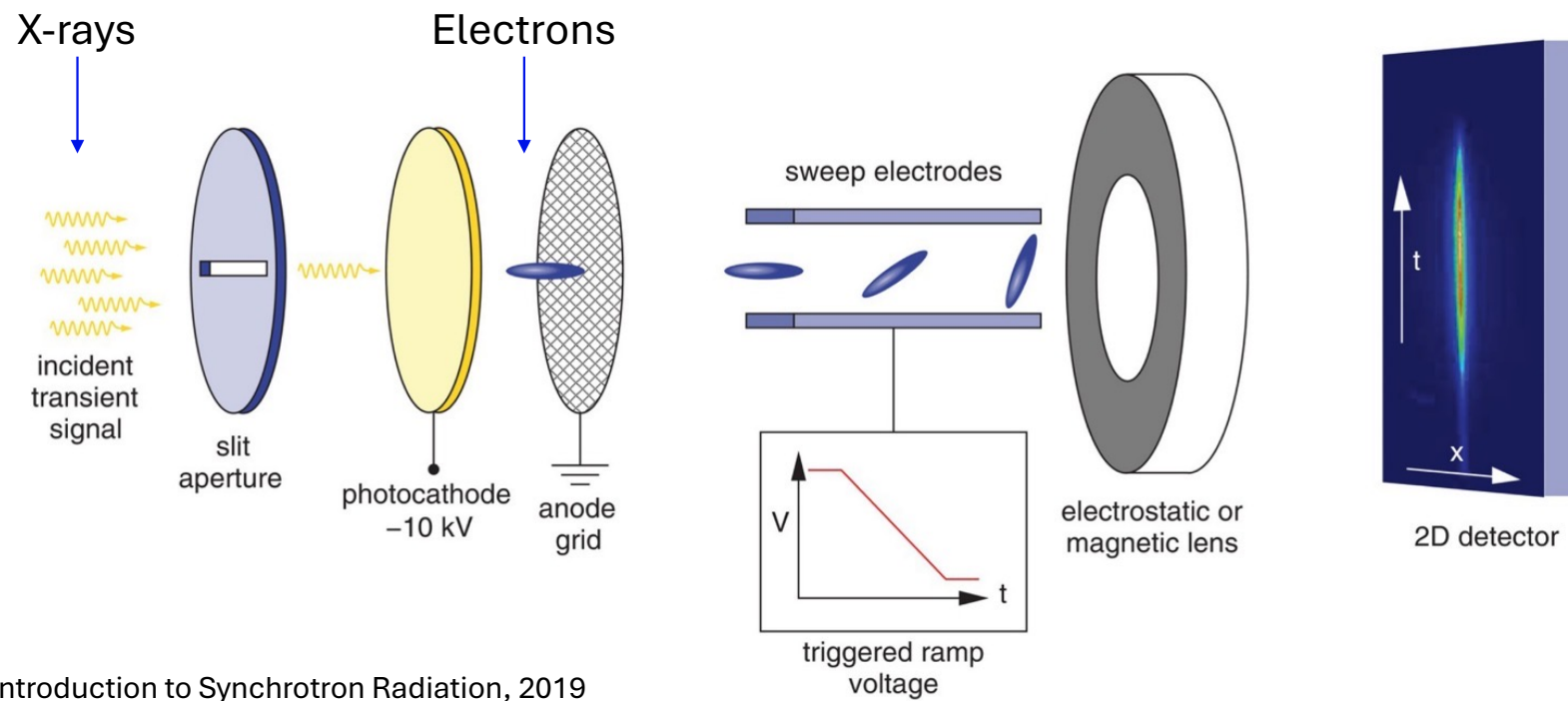

# Streaking at XFEL

## Split and delay principle

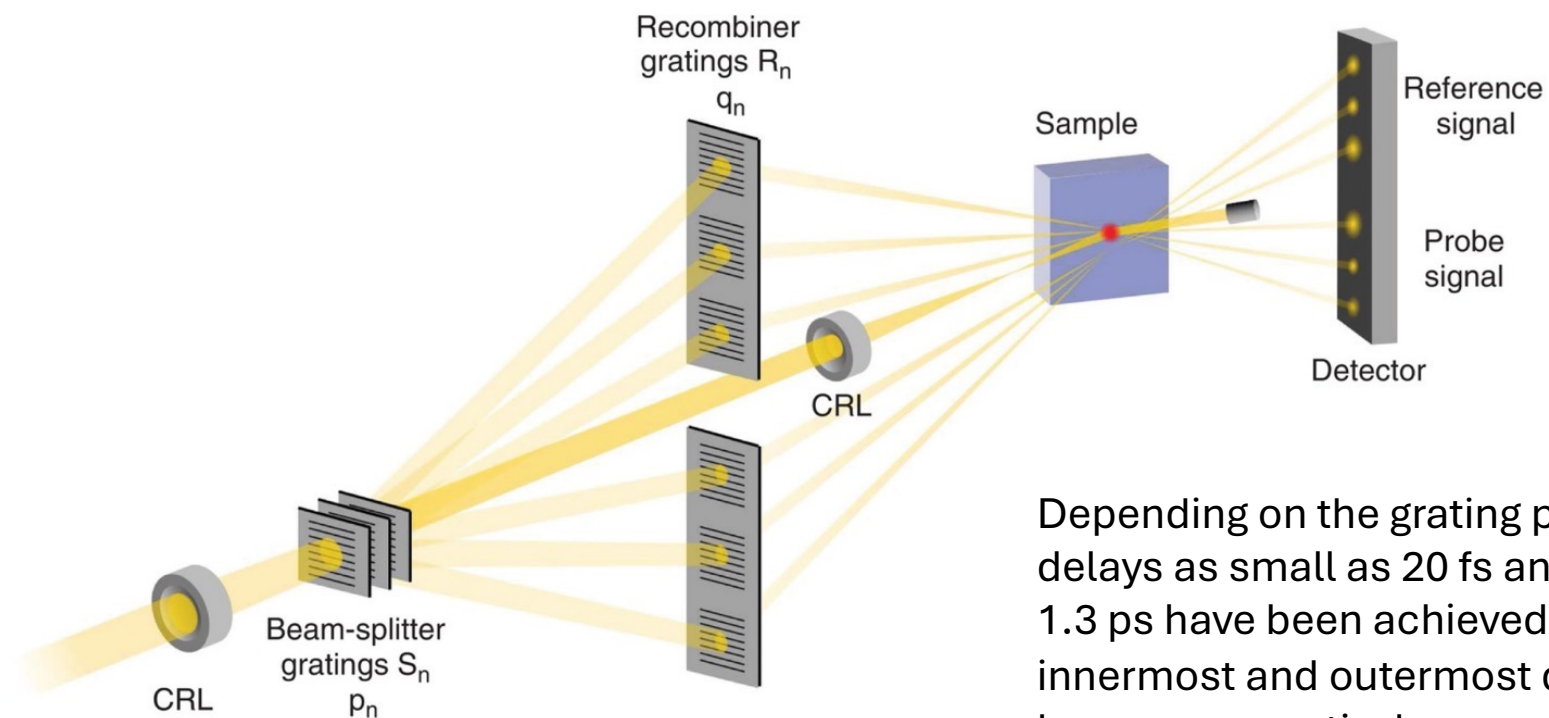

Depending on the grating periodicity, delays as small as 20 fs and as long as 1.3 ps have been achieved for the innermost and outermost diffracted beams, respectively.

## Table of contents

- Neutron beam lines
- Synchrotron beam lines
- X-ray detectors
- **Neutron detectors**

# Neutron detectors

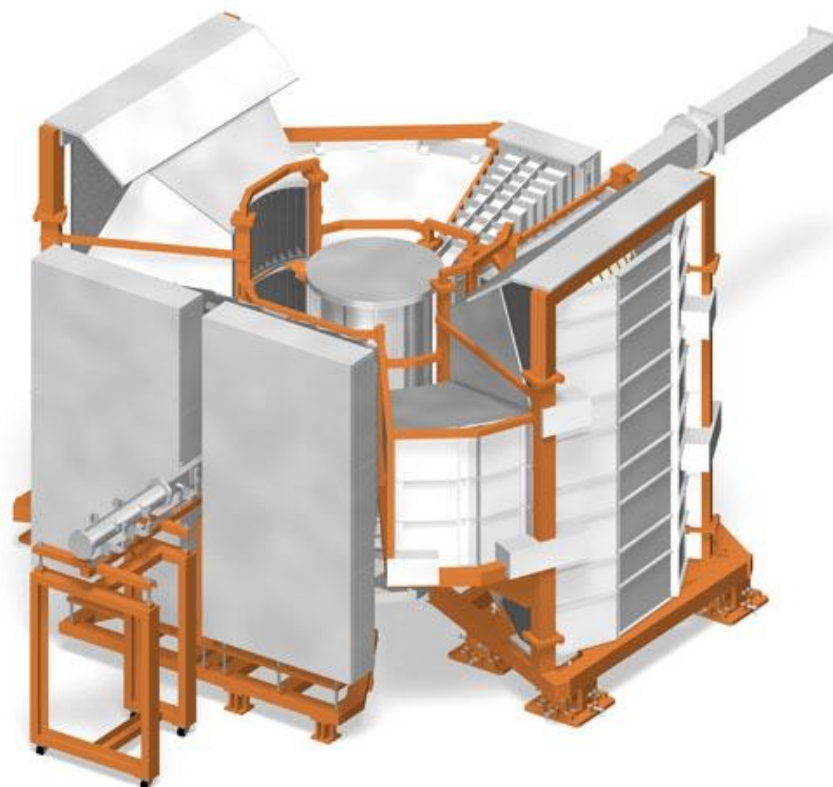

# Neutron detection

What does it mean to “detect” a neutron?

- Need to produce some sort of measurable quantitative (countable) electrical signal
- Can’t directly “detect” slow neutrons

Need to use nuclear reactions to “convert” neutrons into charged particles

Then we can use one of the many types of charged particle detectors

- Gas proportional counters and ionization chambers
- Scintillation detectors
- Semiconductor detectors

## Nuclear reactions for neutron detectors

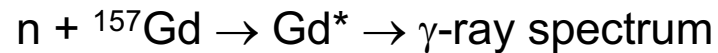
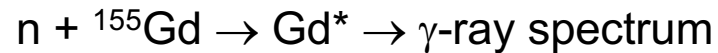
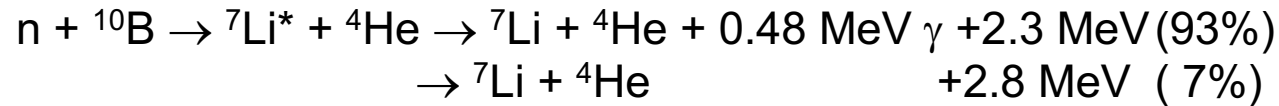
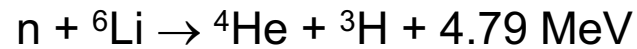
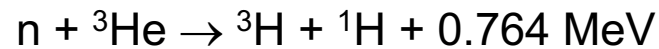

## <sup>3</sup>He detectors

Natural abundance: 0.000137%

By-product of radioactive decay of tritium (nuclear weapons program)



U.S. mass production of tritium ceased in the mid 1990's (weapons reduction)

U.S. demand increased after Sept 11, 2001 (portal monitors, border security)

In 2008 a critical shortage of helium-3 in the U.S. was realized (supply << demand)

BF<sub>3</sub> commonly used as neutron gas detector prior to the widespread availability of He-3

- but BF<sub>3</sub> is a toxic, corrosive gas (He-3 is inert)
- nevertheless, some facilities have recently revisited BF<sub>3</sub> due to the He-3 shortage

## $^3\text{He}$ detectors

The reaction:  $n + ^3\text{He} \rightarrow ^3\text{H} + ^1\text{H} + 0.764 \text{ MeV}$

Momentum Conservation – trajectories antiparallel

Energy Conservation – KE split inversely proportional to mass (3:1)

- proton kinetic energy = 573 keV
- triton kinetic energy = 191 keV

Reaction products lose energy through interactions with gas atoms (excitation and ionization)

Stopping gases are added to reduce size of charge cloud: Ar,  $\text{C}_3\text{H}_8$ ,  $\text{CF}_4$

## $^3\text{He}$ detectors

- Positive HV on wire, E field falls off as  $1/r$  (strong near wire)
- Electrons drift in toward wire (anode), ions drift out toward grounded tube wall (cathode), but at velocities  $\sim 1000$  times slower
- Current pulse is measured, proportional to charge collected on wire (Shockley-Ramo theorem).
- If voltage is high enough, electron collisions ionize gas atoms producing even more electrons

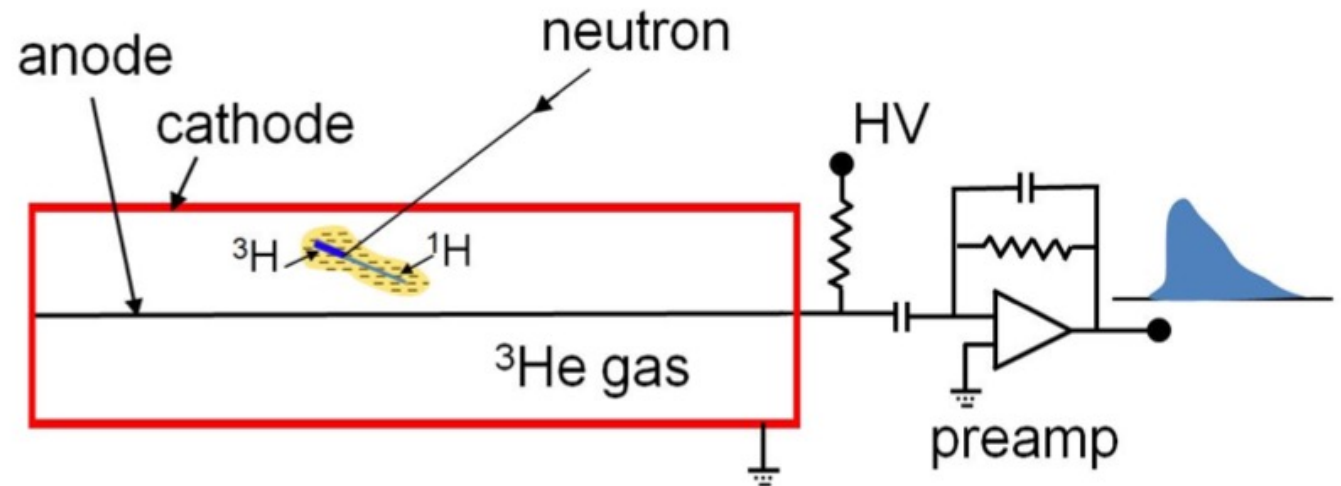

# Linear position sensitive $^3\text{He}$ detector

- Modular Assembly “8 packs”
- Preamplifier at each end of tube
- Current divides according to resistance it sees to preamps
- Current from both preamps is measured, location is determined by:

$$(A - B)/(A + B)$$

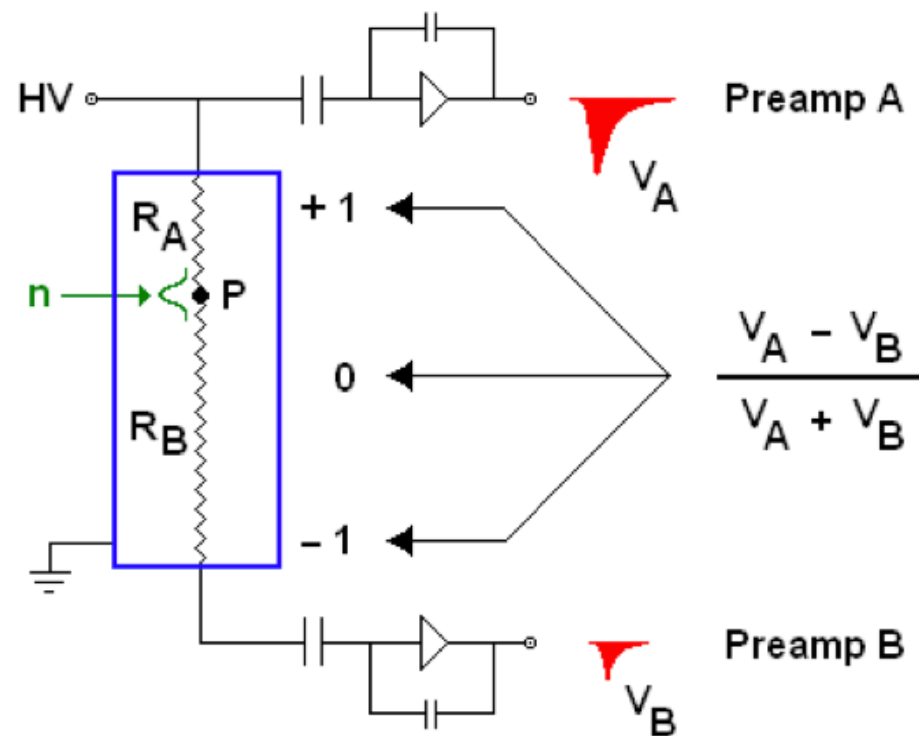
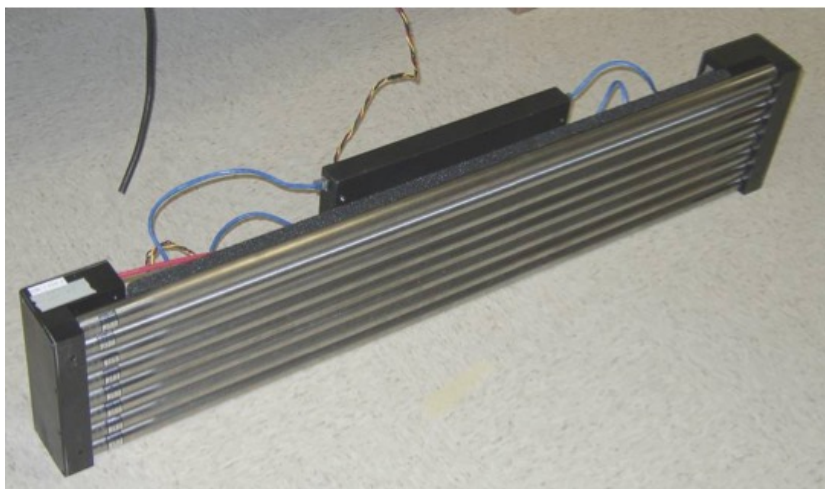

# Multi-wire $^3\text{He}$ area detectors

- X and Y orthogonal cathodes with anode between at + high voltage
- Charge at anode induces signal on cathodes
- Preamps distributed evenly
- Resistive charge division between each pair of nodes (preamps)
- Interpolation based on signals from three wires:

$$(C - A) / (A + B + C)$$

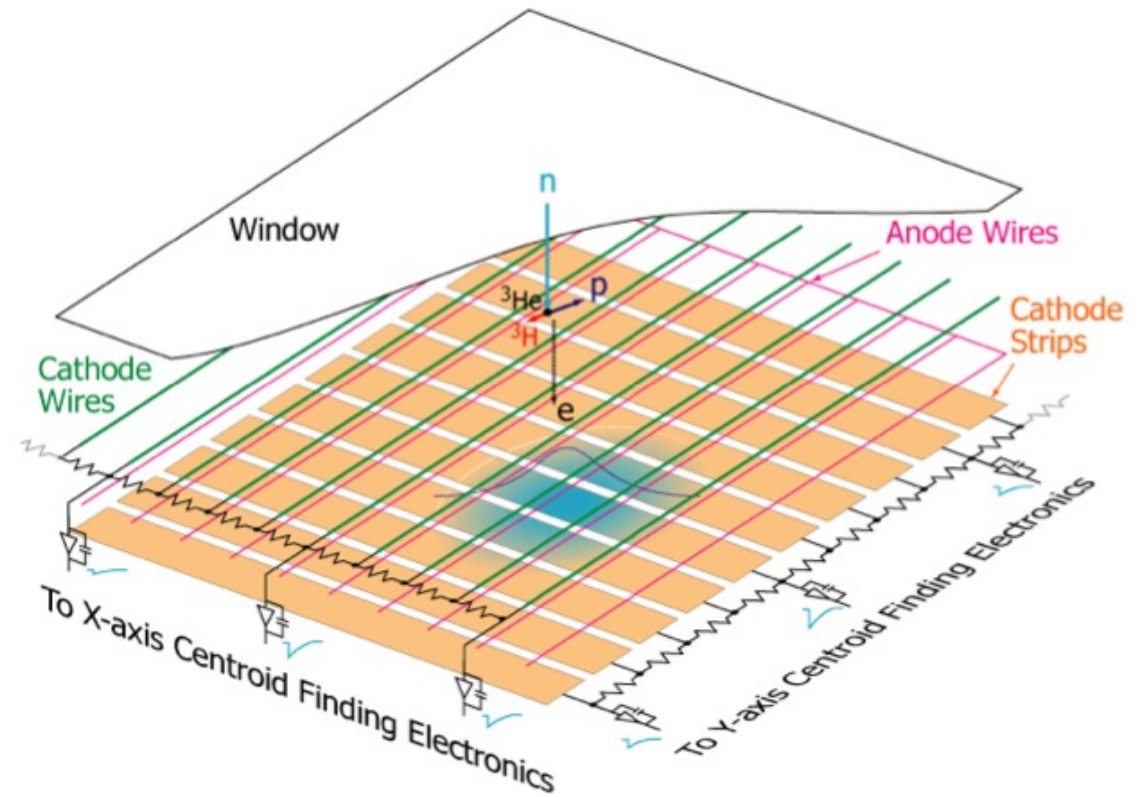

# Scintillator detectors

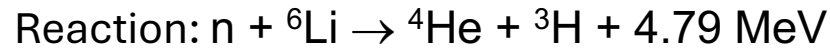

Material	Density of ${}^6\text{Li}$ atoms (cm <sup>-3</sup> )	Scintillation efficiency	Photon wavelength (nm)	Photons per neutron
Li glass (Ce)	$1.75 \times 10^{22}$	0.5%	395	~7000
Lil (Eu)	$1.83 \times 10^{22}$	2.8%	470	~51'000
ZnS (Ag) – LiF	$1.18 \times 10^{22}$	9.2%	450	~160'000

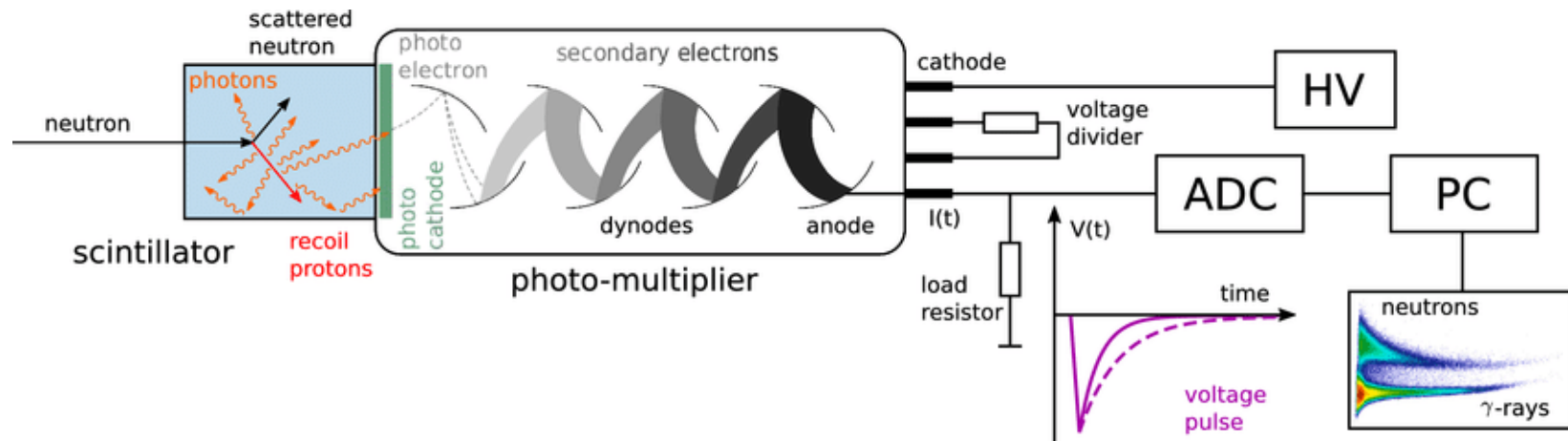

## Scintillator detectors

Example: Engin-X at ISIS (Rutherford lab, UK)

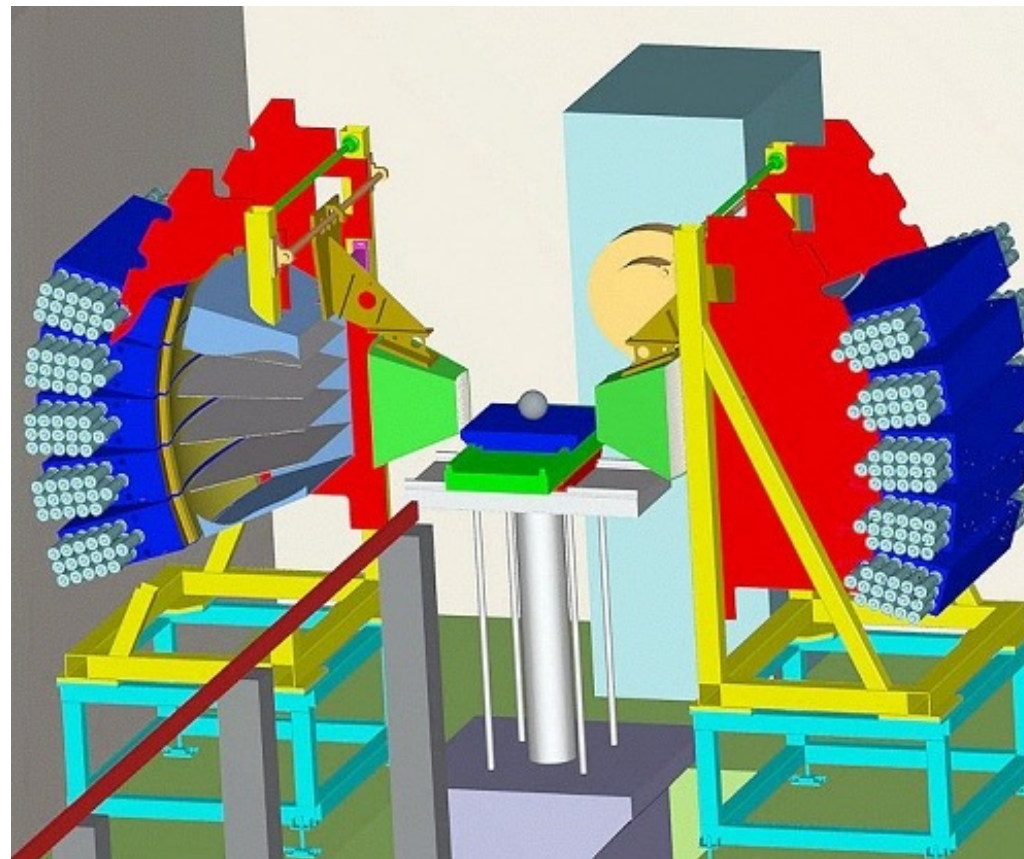

## Other detection systems

- X-ray film in connection with converter foils from Gd, Dy, oder In. The excitation and blackening of the film is caused by gamma and beta radiation as well as by conversion electrons.
- Highly light sensitive CCD camera detectors (cooled in most cases) looking onto the weak light emission from a neutron sensitive scintillator (Li-6 or Gd as neutron absorber).
- Imaging Plates contain Gd as neutron absorber and BaFBr:Eu 2+ as the agent which provides the photoluminescence.
- Flat panels based on amorphous silicon