



Materials Science at Large Scale Facilities

Sources

Steven Van Petegem
EPFL course MSE-435

Table of contents



- **Neutron sources**
 - **Neutron reactors**
 - **Spallation neutron sources**
- Synchrotrons
- X-ray Free Electron Laser

Development of Neutron Research Facilities

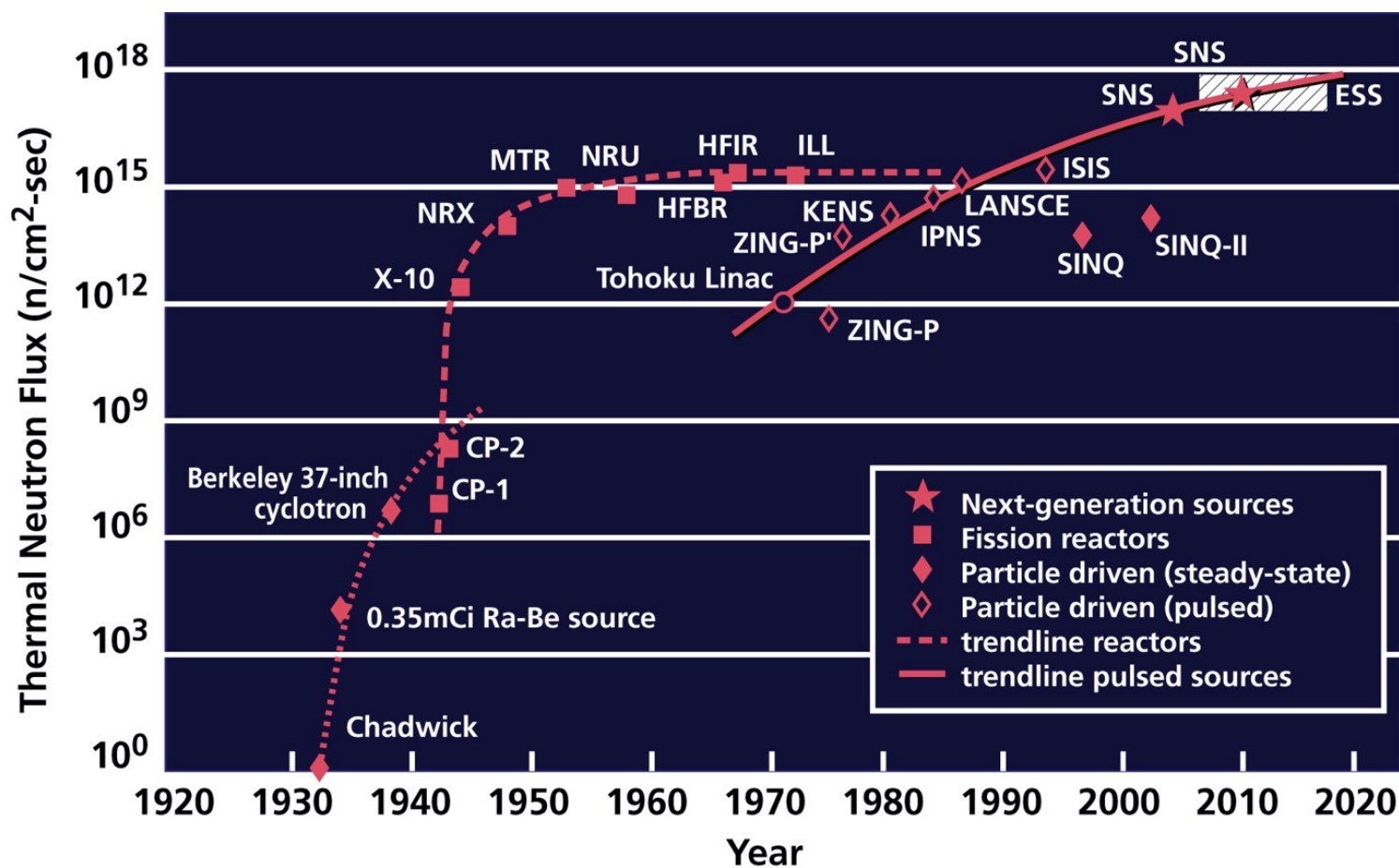

(Updated from *Neutron Scattering*, K. Skold and D. L. Price: eds., Academic Press, 1986)

Neutron production

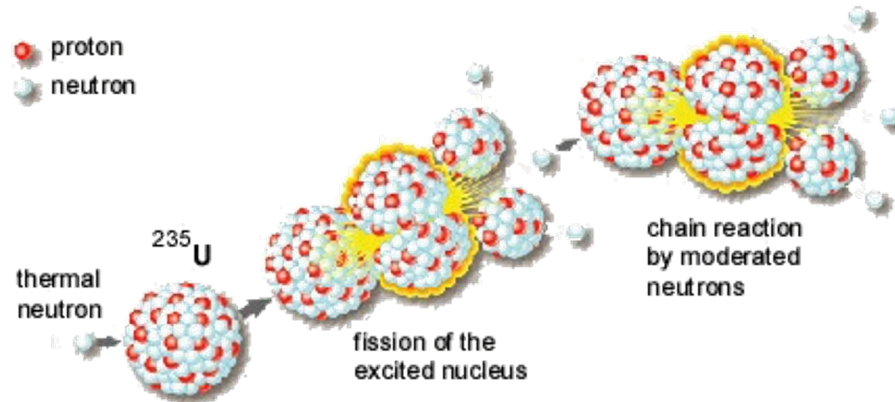

Fission

- Chain reaction
- Continuous flow
- ~ 1 neutron/fission

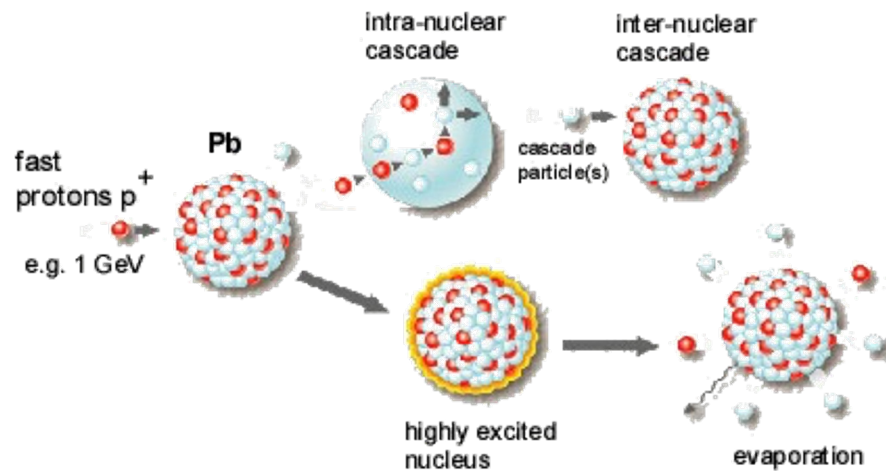

Spallation

- No chain reaction
- Accelerator driven
- Pulsed operation
- ~ 30 neutrons/proton

Neutron production - fission

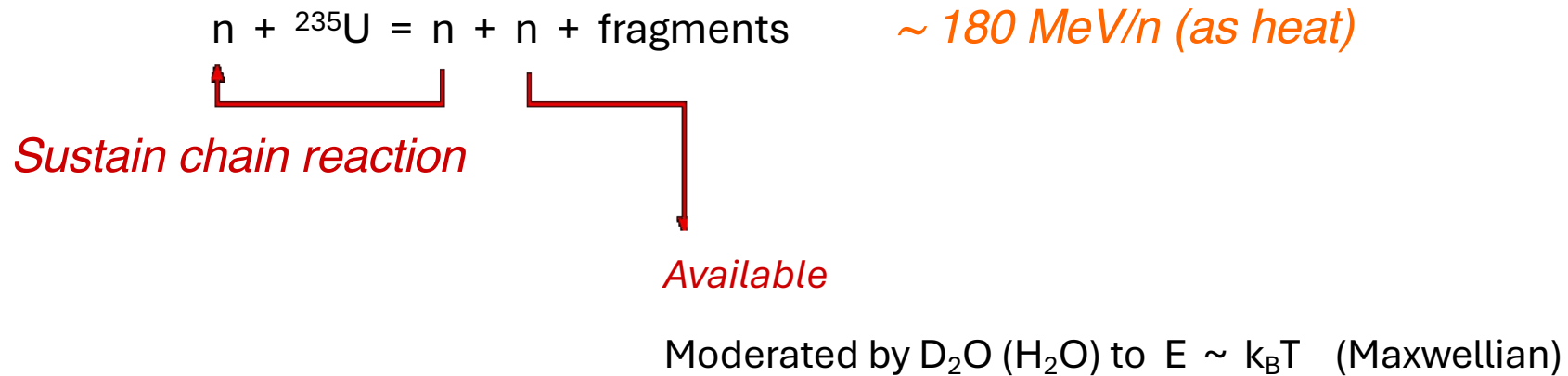

The chain reaction is started by inserting a neutron source, such as Californium-252 or Plutonium-238

Neutron production - spallation

$p + \text{heavy nucleus} = 20 \sim 30 n + \text{fragments}$

1 GeV e.g. W, Pb, U

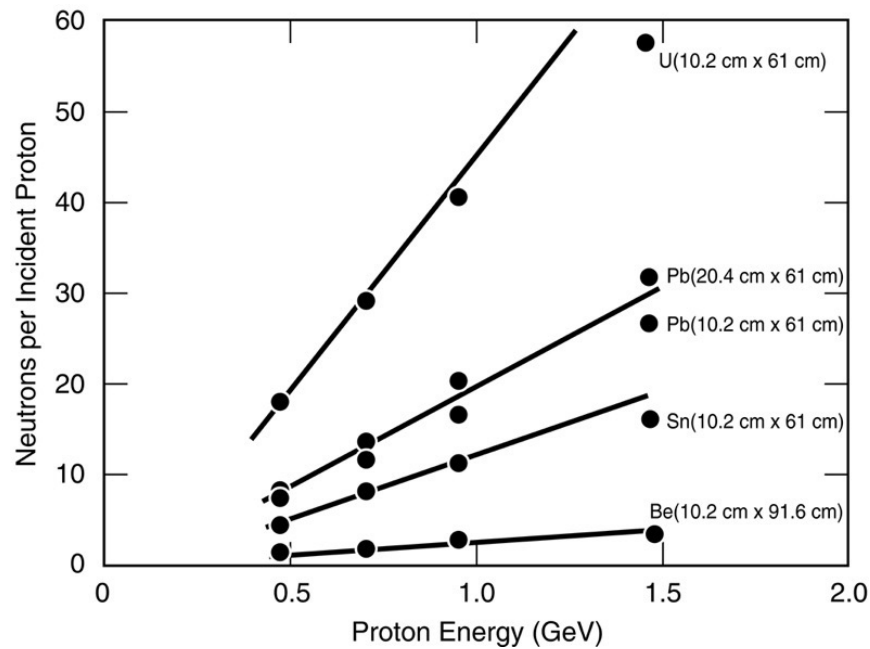

$\sim 30 \text{ MeV/n (as heat)}$

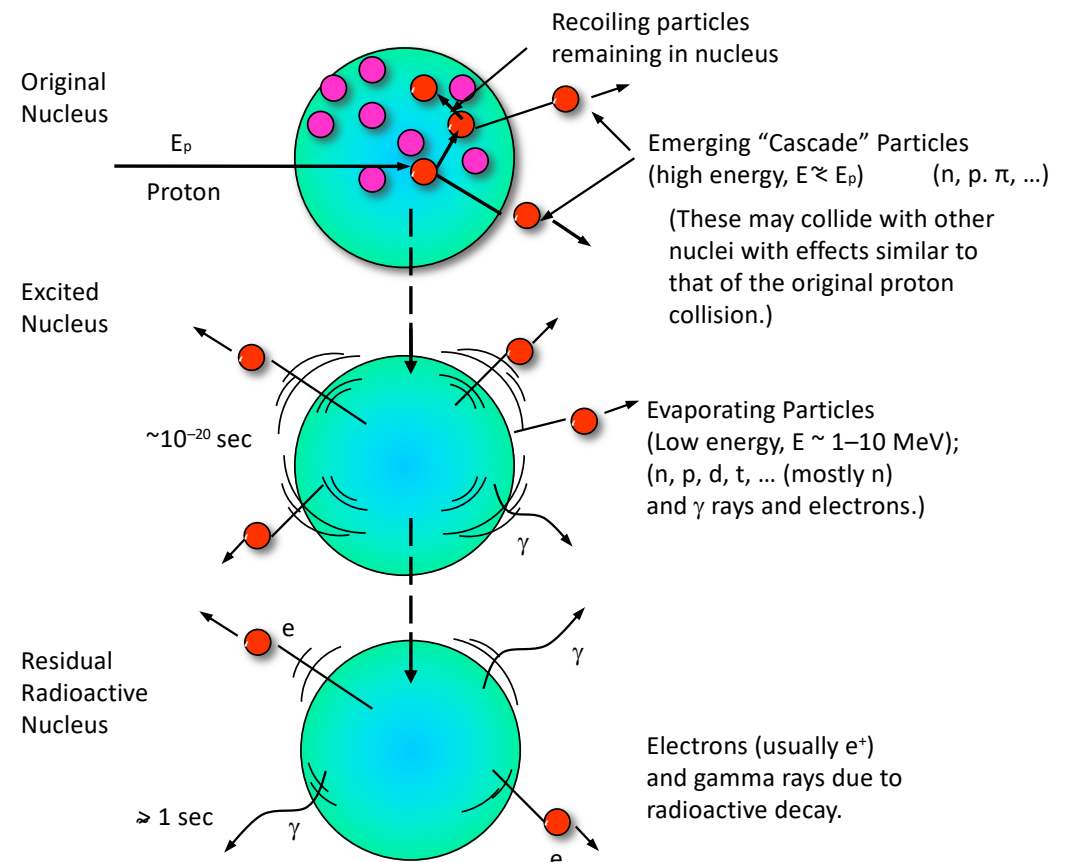

Neutron reactors

- Reactor e.g., HFR at ILL, Grenoble, France.

$$\sim 1.5 \times 10^{15} \text{ n/cm}^2/\text{s}$$

Advantages

- High time averaged flux.
- Mature technology
- Very good for cold neutrons

Drawbacks

- Licensing (cost/politics).
- No time structure.

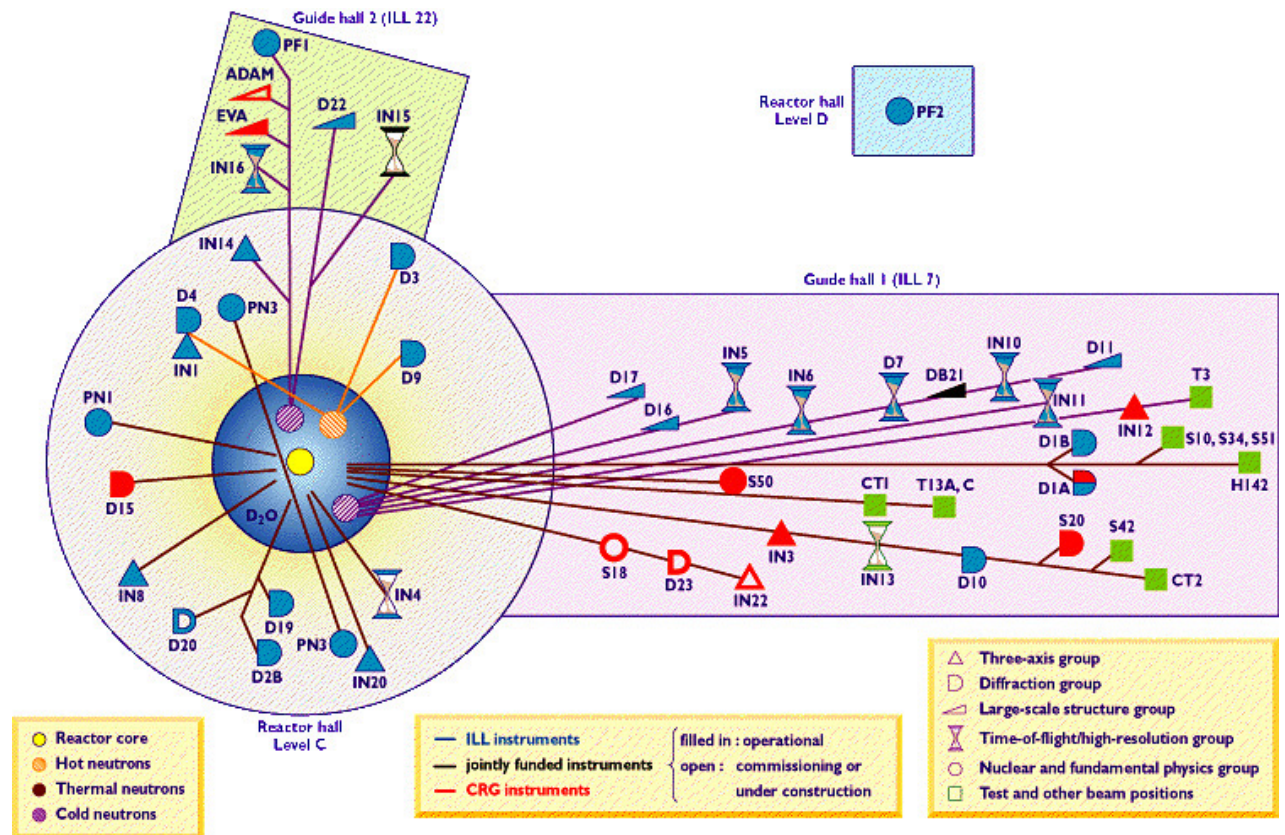

Neutron reactors

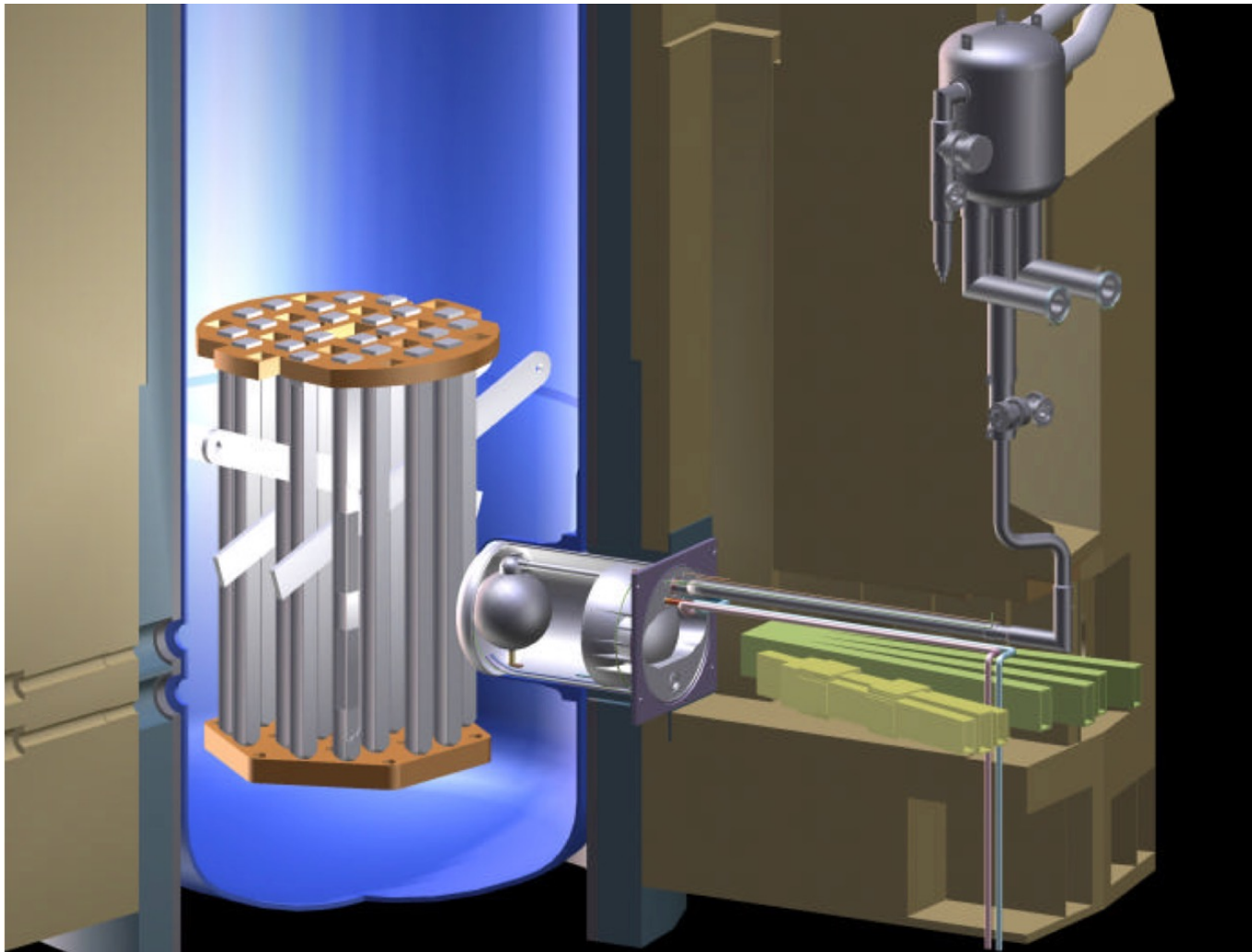

The National Institute of Standards and Technology (NIST) Reactor is a 20 MW research reactor with a peak thermal flux of 4×10^{14} N/sec. It is equipped with a unique liquid-hydrogen moderator that provides neutrons for seven neutron guides

Spallation sources

Pulsed spallation sources e.g., IPNS, ISIS, LANSCE, SNS

Advantages

- High peak flux.
- Politically acceptable.
- Advantageous time structure for many applications.
- Accelerator based – politics simpler than reactors.
- Technology rapidly evolving.

Disadvantages

- Low time averaged flux.
- Not all applications exploit time structure.

Spallation sources - LANSCE

- Linac produces 20 H⁻ (a proton + 2 electrons) pulses per second
 - 800MeV, ~800 μsec long pulses, average current ~100μA
- Each pulse consists of repetitions of 270 nsec on, 90 nsec off
- Pulses are injected into a Proton Storage Ring with a period of 360 nsec
 - Thin carbon foil strips electrons to convert H⁻ to H⁺ (i.e. a proton)
 - ~3x10¹³ protons/pulse ejected onto neutron production target

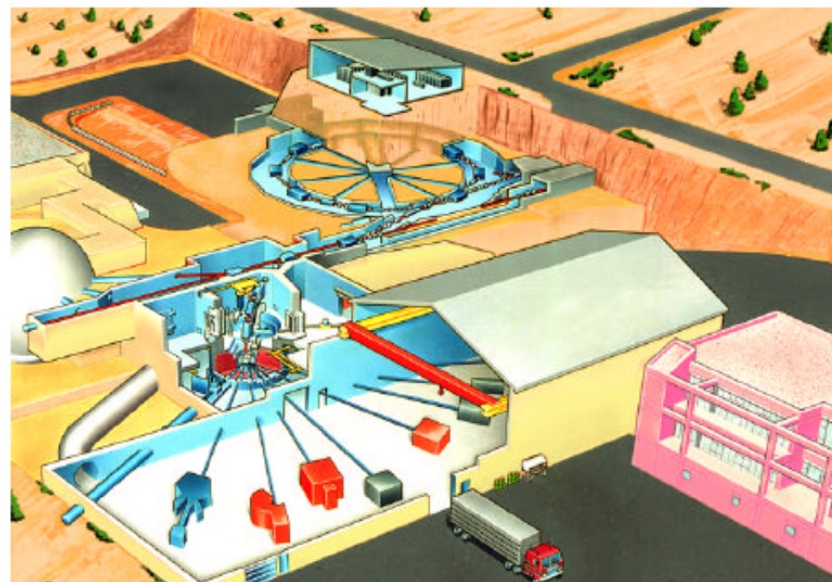
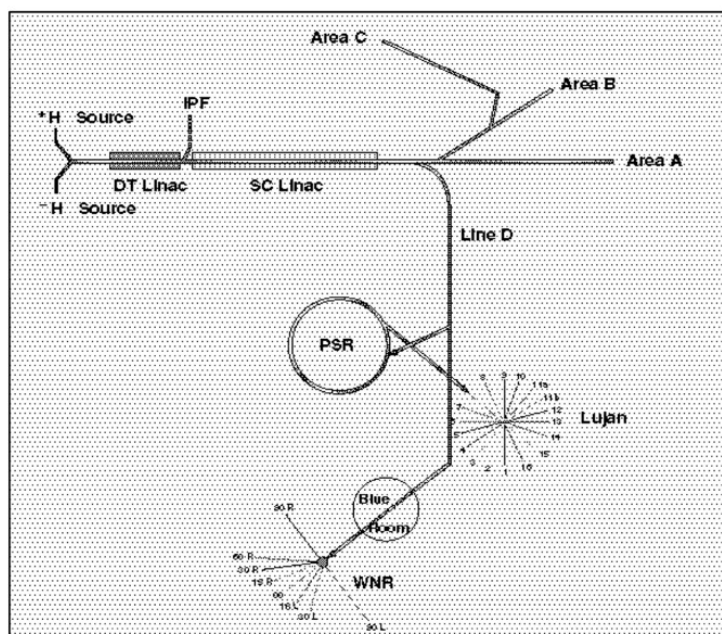

Spallation sources

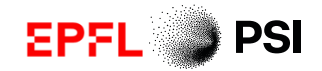

- **CW spallation source** e.g., SINQ at Paul Scherrer Institut (PSI).
0.85 mA, 590 MeV, 0.9 MW
 1×10^{14} n/cm²/s average flux

Advantages

- High time averaged flux.
- Uses reactor type instrumentation (mature technology).
- Politically acceptable.
- piggy-backed on existing accelerator.

Disadvantages

- No time structure.

SINQ – Swiss Spallation Neutron Source

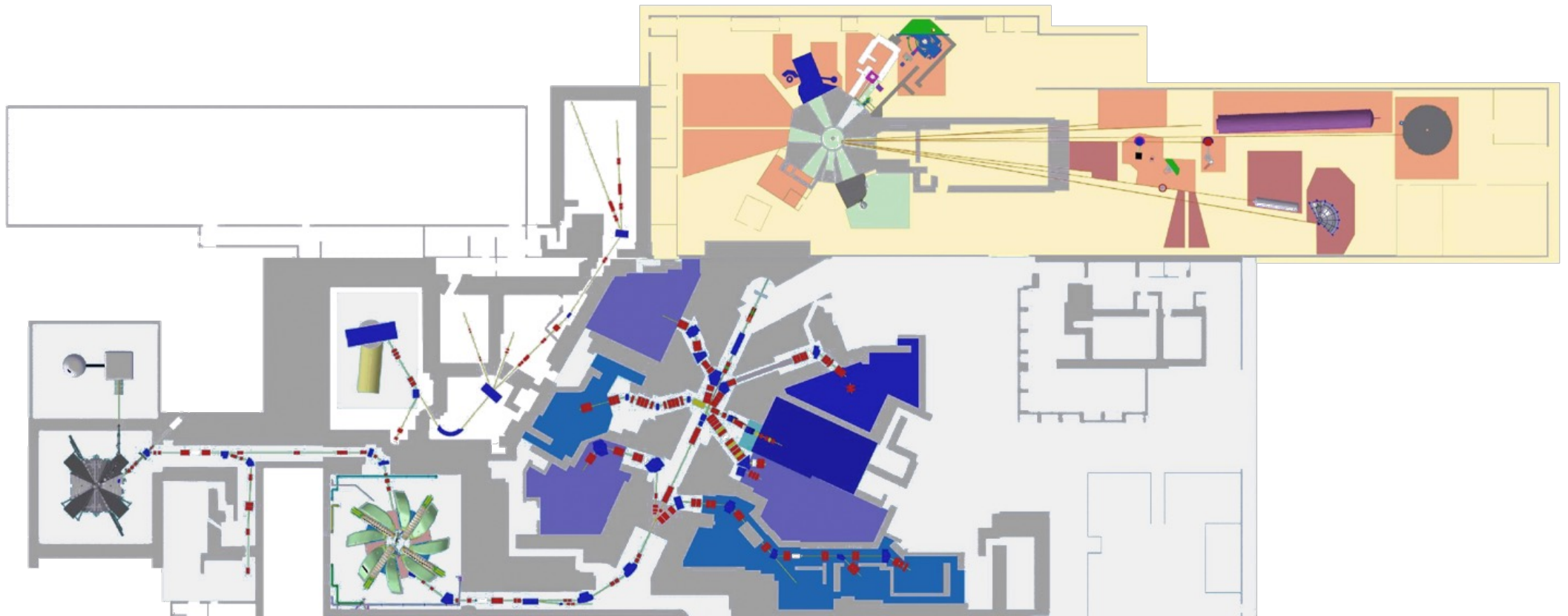

Generation of a proton beam

In the plasma chamber hydrogen atoms are separated into a mixture of protons and electrons by collisions with free electrons.

The protons are extracted from this plasma by a 60kV electric field and directed to the accelerator tube, which forms them into a beam with a particle velocity of 5% of the speed of light.

1 electron volt is the energy that a single positively charged particle possesses after it has passed through a potential difference of 1 volt. It is therefore about 0.16 trillionth of a joule.

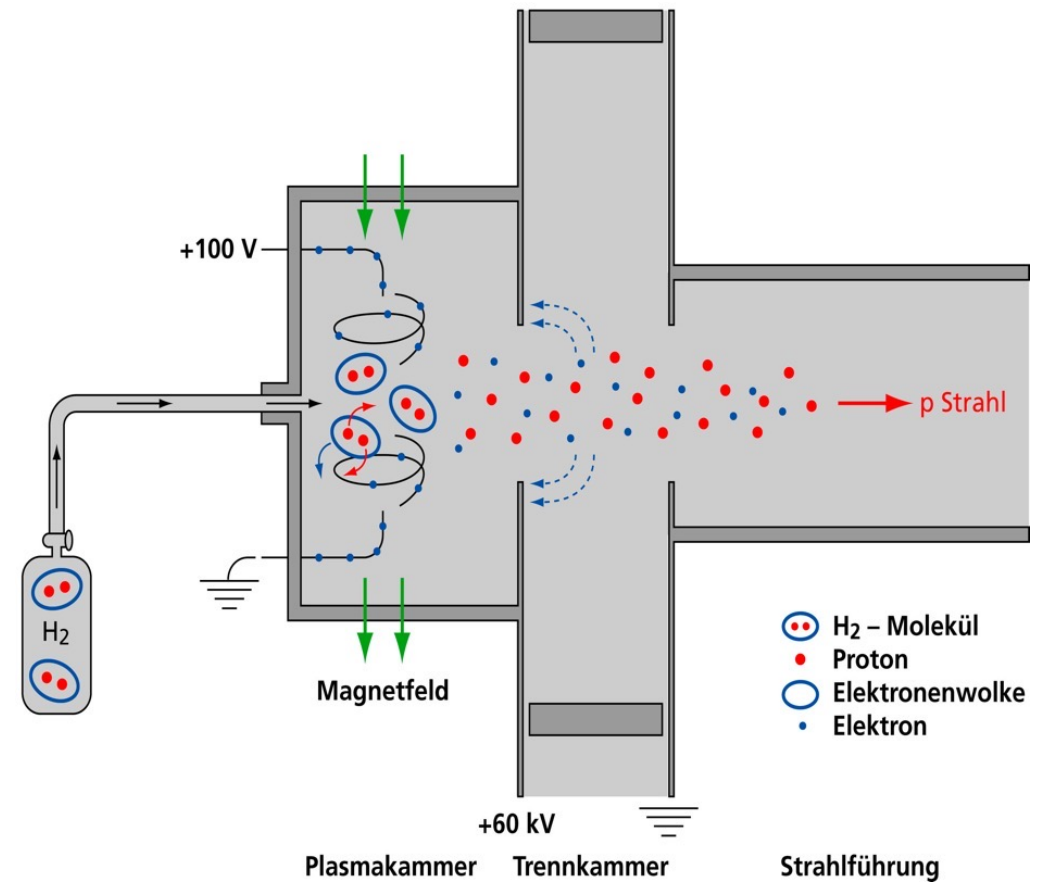

Cockcroft-Walton accelerator

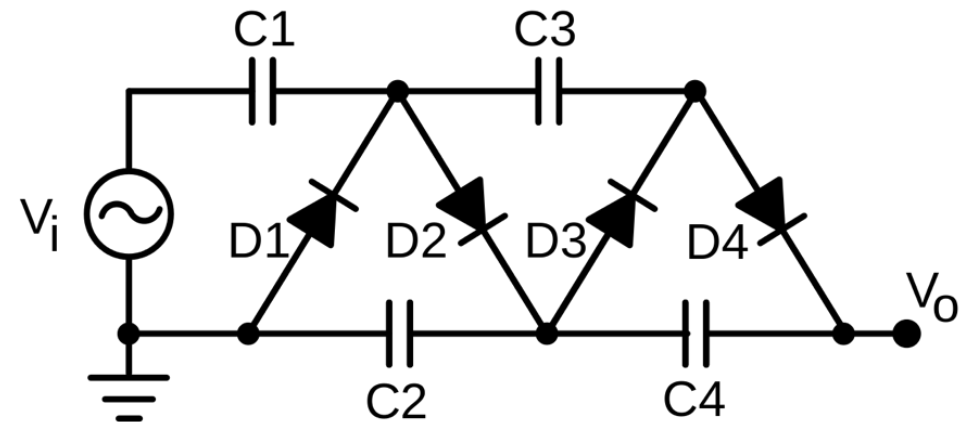

- Voltage multiplier
- Basic principle:
<https://www.youtube.com/watch?v=ljUmDU4Uzp8>
- Maximum $\sim 10\text{MV}$
- @PSI: 0.87MV

Accelerators – basic principles

Consider the acceleration between two electrodes in DC

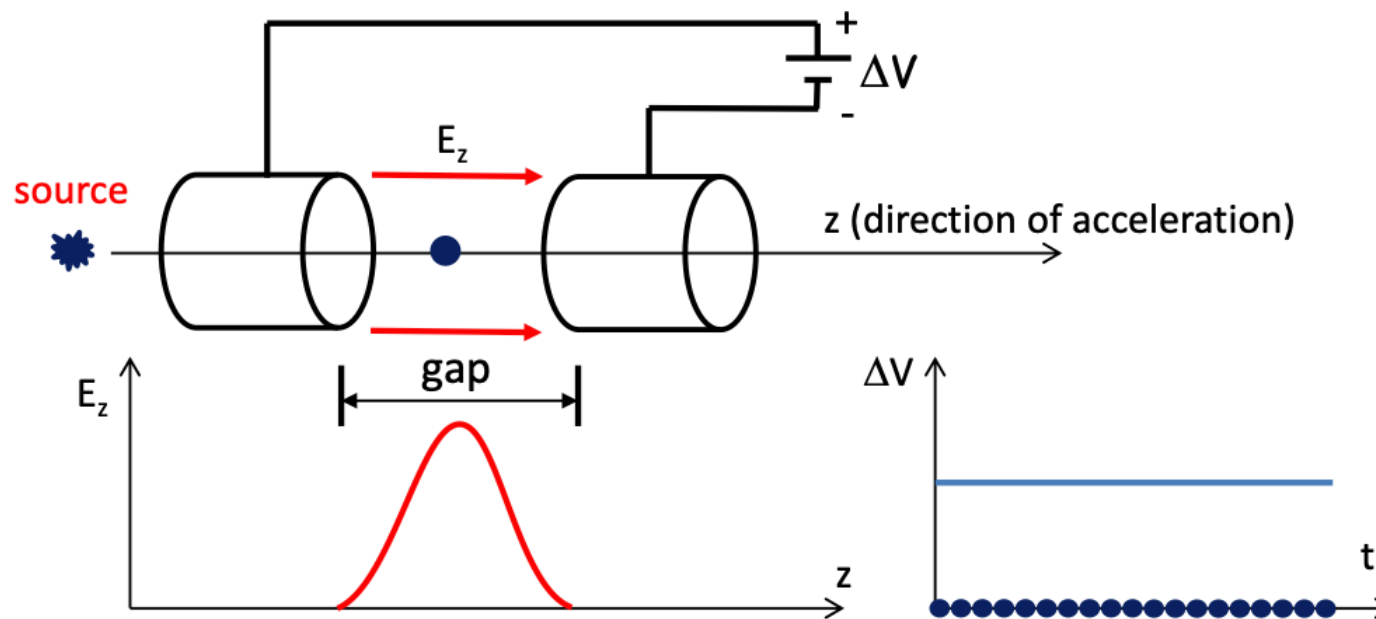

Energy gain per electrode: $\Delta E = q\Delta V$

<https://cas.web.cern.ch/sites/default/files/lectures/constantia-2018/alesinilinearaccelerators.pdf>

Accelerators – basic principles

Consider the acceleration between two electrodes fed by an RF generator

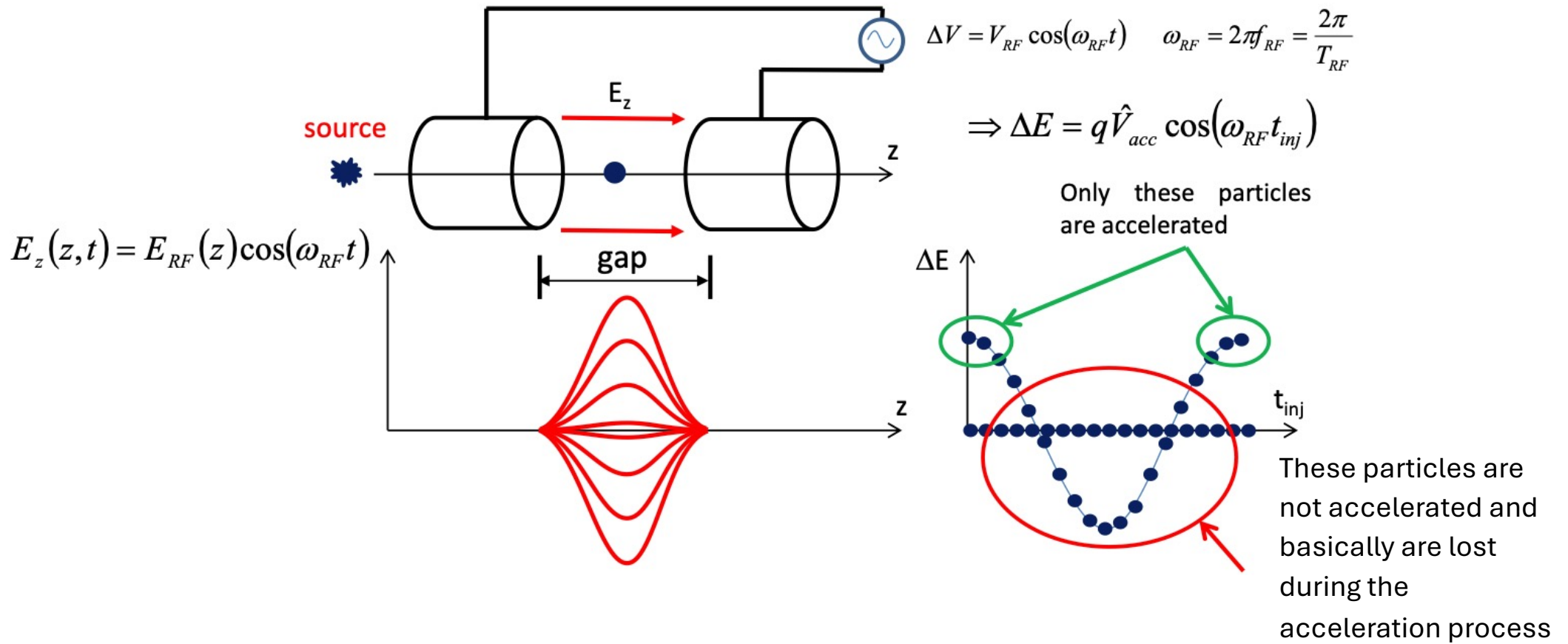

Accelerators – basic principles

In praxis: use a cavity which resonant frequency matches the RF generator frequency. Each cavity can be independently powered from the RF generator

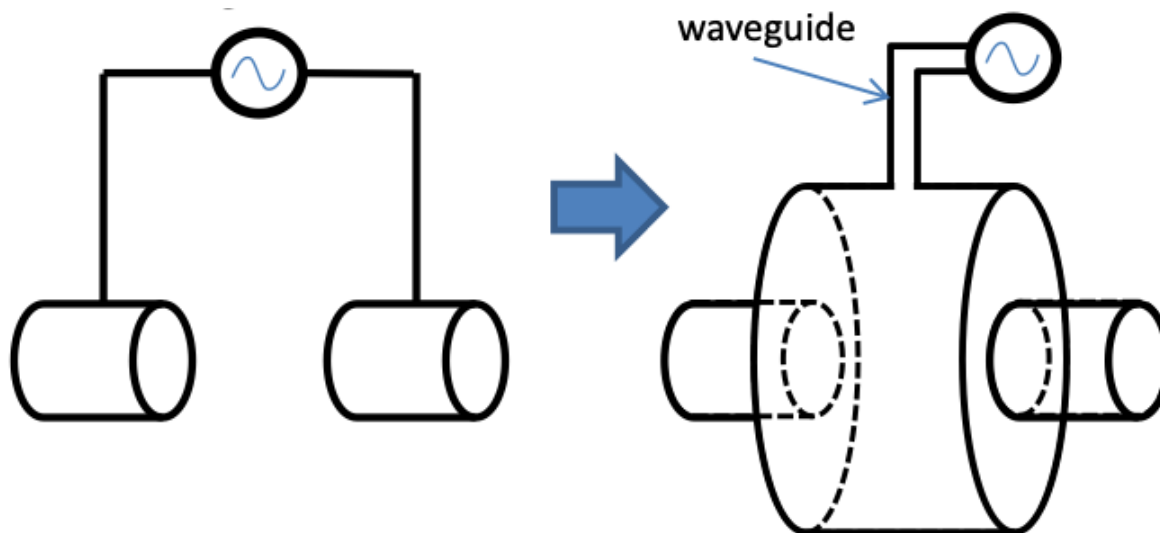

- The cavities are metallic closed volumes where the electromagnetic fields have a particular spatial configuration (resonant modes).
- The modes are excited by RF generators that are coupled to the cavities.
- The resonant modes are called Standing Wave (SW) modes (spatial fixed configuration, oscillating in time).

Cyclotron

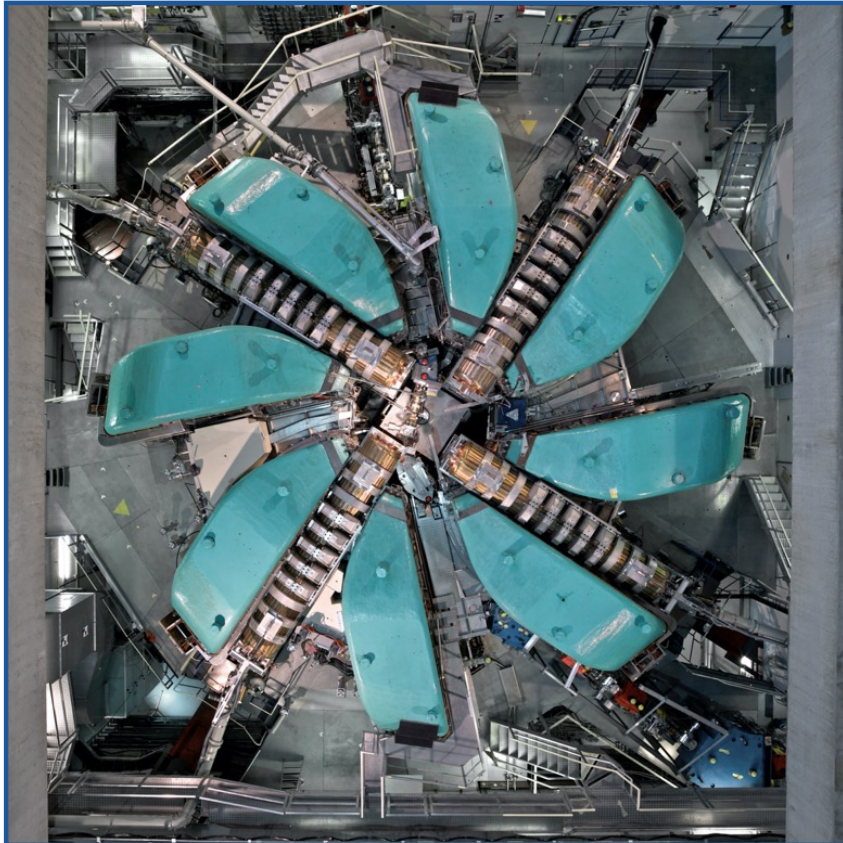

The main accelerator consisting of eight separate sector magnets and four high-frequency cavities, specially designed to accelerate a high-intensity proton beam.

Injection energy:	72 MeV
Extraction energy:	590 MeV
Beam current:	1.6 mA
Time between two packets:	19.75 ns

In the cyclotron, the proton beam is brought to a final energy of 590 MeV (82% of the speed of light). This means that a proton would fly around the earth approx. 6 times in one second (circumference of the earth approx. 40,000 km).

The proton beam current is approx. 2.4 mA, resulting in a beam power of over 1.3 MW.

Swiss Spallation Neutron Source

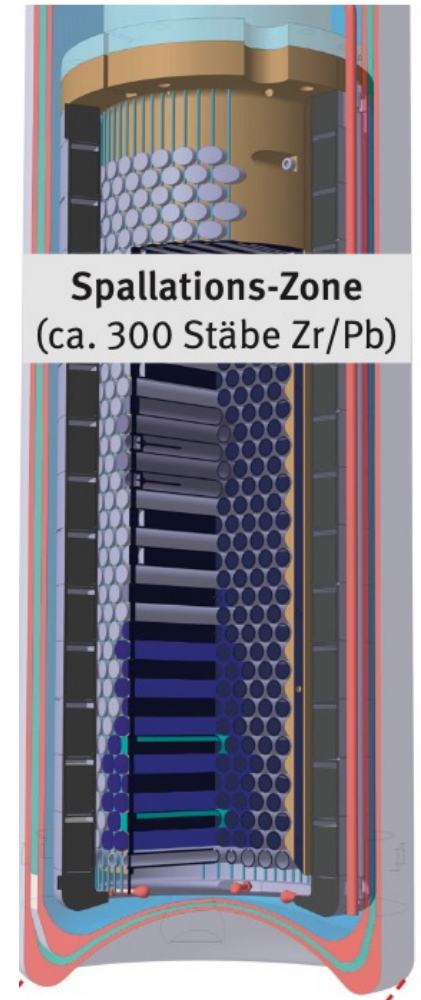
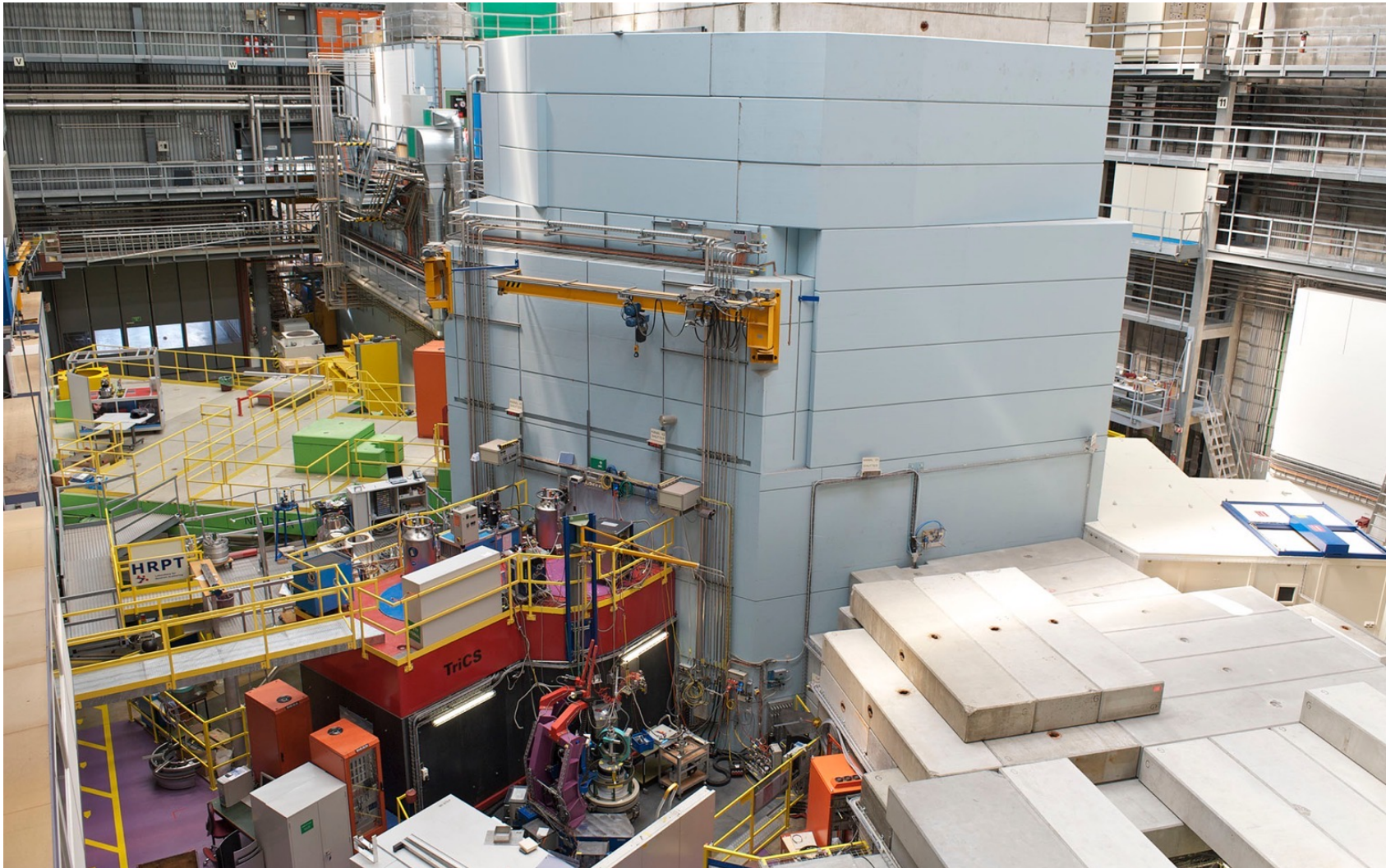

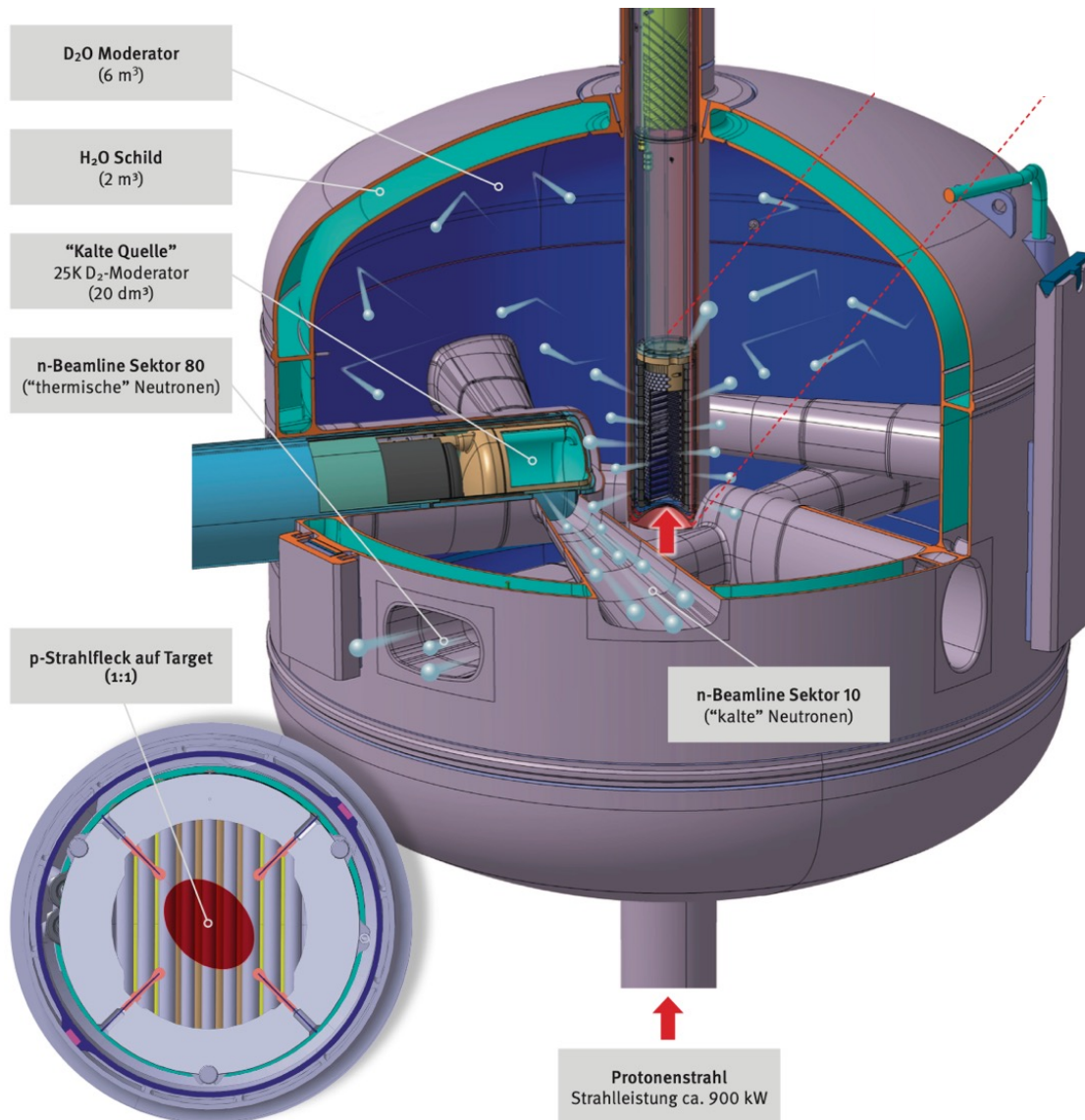

The neutrons that are released leave the target at a speed of about 20'000 km/s. Since this is too fast for materials science purposes, they are slowed down. This is done by atomic collisions in a moderator material that surrounds the target. After that, the neutrons still have a speed of about 2200 m/s, they are called thermal neutrons. If the neutrons are additionally decelerated in a very cold medium (liquid heavy hydrogen at -250°C), they become even slower. We then speak of cold neutrons, which still have a velocity of about 700 m/s.

Very fast neutrons that cannot be slowed down in the moderator have to be absorbed by the 5 m thick shielding made of iron and special concrete. In the process, their kinetic energy is converted into heat. The inner part of the shielding must therefore be cooled with water.

Neutron sources - flux

Reactors

DR3	Risø	2.0×10^{14} n/cm ² /s
ILL	Grenoble	1.5×10^{15} n/cm ² /s
FMR-II	Garching	8.0×10^{14} n/cm ² /s

Spallation sources

ISIS @ 160 kW	average	1.2×10^{13} n/cm ² /s
	peak	6.0×10^{15} n/cm ² /s
SNS @ 2 MW	average	4.0×10^{13} n/cm ² /s
	peak	3.0×10^{16} n/cm ² /s

Cooling down

Neutrons	Energy range	Wavelength [\AA]	Velocity [m/s]
ultra cold	$\leq 300 \text{ neV}$	≥ 500	≤ 8
very cold	300 neV - 0.12 meV	52.2 – 26.1	7.5 – 152
cold	0.12 meV - 12 meV	26.1 – 2.6	152 – 1515
thermal	12 meV - 100 meV	2.6 - 0.9	1515 - 4374
epithermal	100 meV - 1eV	0.9 - 0.28	4374 - $13.8 \cdot 10^3$
intermediate	1eV - 0.8MeV		
fast	$> 0.8\text{MeV}$		

Ultra cold neutron source

- The full intensity proton beam (1) – 1.5×10^{16} protons/s – impinges for up to 8s onto the spallation target (2) built out of 760 lead-filled Zircalloy tubes.
- Subsequently, neutrons are thermalized in the surrounding ultraclean heavy water (D₂O) (3) operating at a temperature of ~300 K. This water is also used to cool the spallation target.
- Solid deuterium at 5 K inside the D₂ vessel (4) allows further cooling of the neutrons, resulting in a cold neutron flux of a few times 10^{13} n/cm²/s.
- These neutrons are finally down-scattered to become ultracold via phonon interaction with the solid D₂.
- The UCN emanating at the top lose this boost energy in the 1 m rise in the vertical guide (5) and enter the ~2 m³ large UCN storage vessel (7) coated with diamond-like carbon.

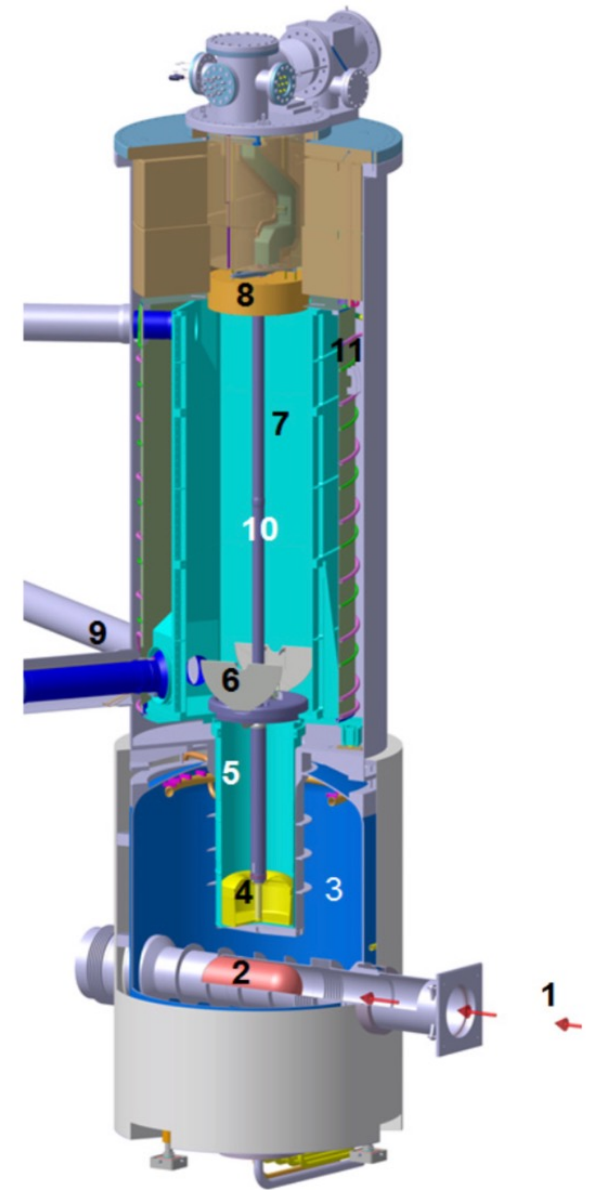

Spallation Neutron Source



Oak Ridge, USA
Currently most intense pulsed neutron source
Cost: ~1.4 billion dollar

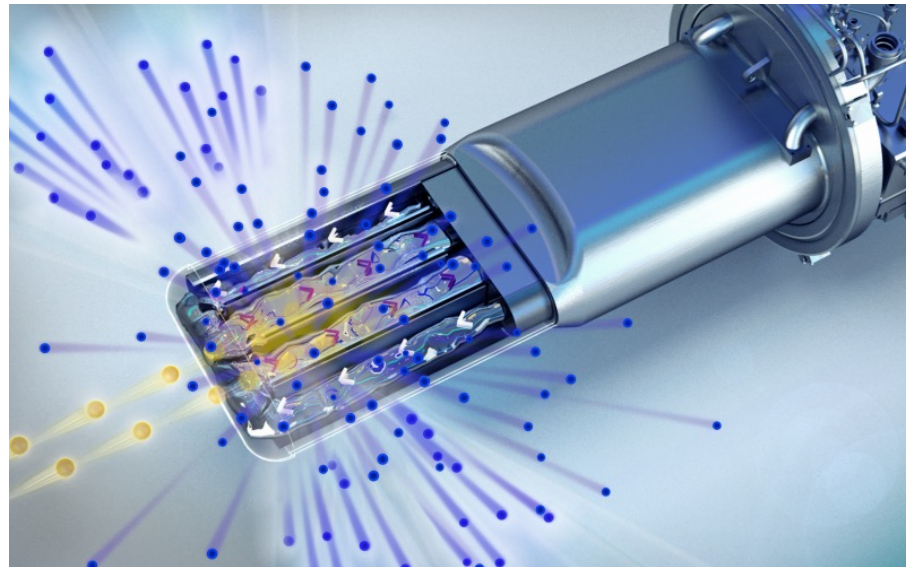

Spallation Neutron Source

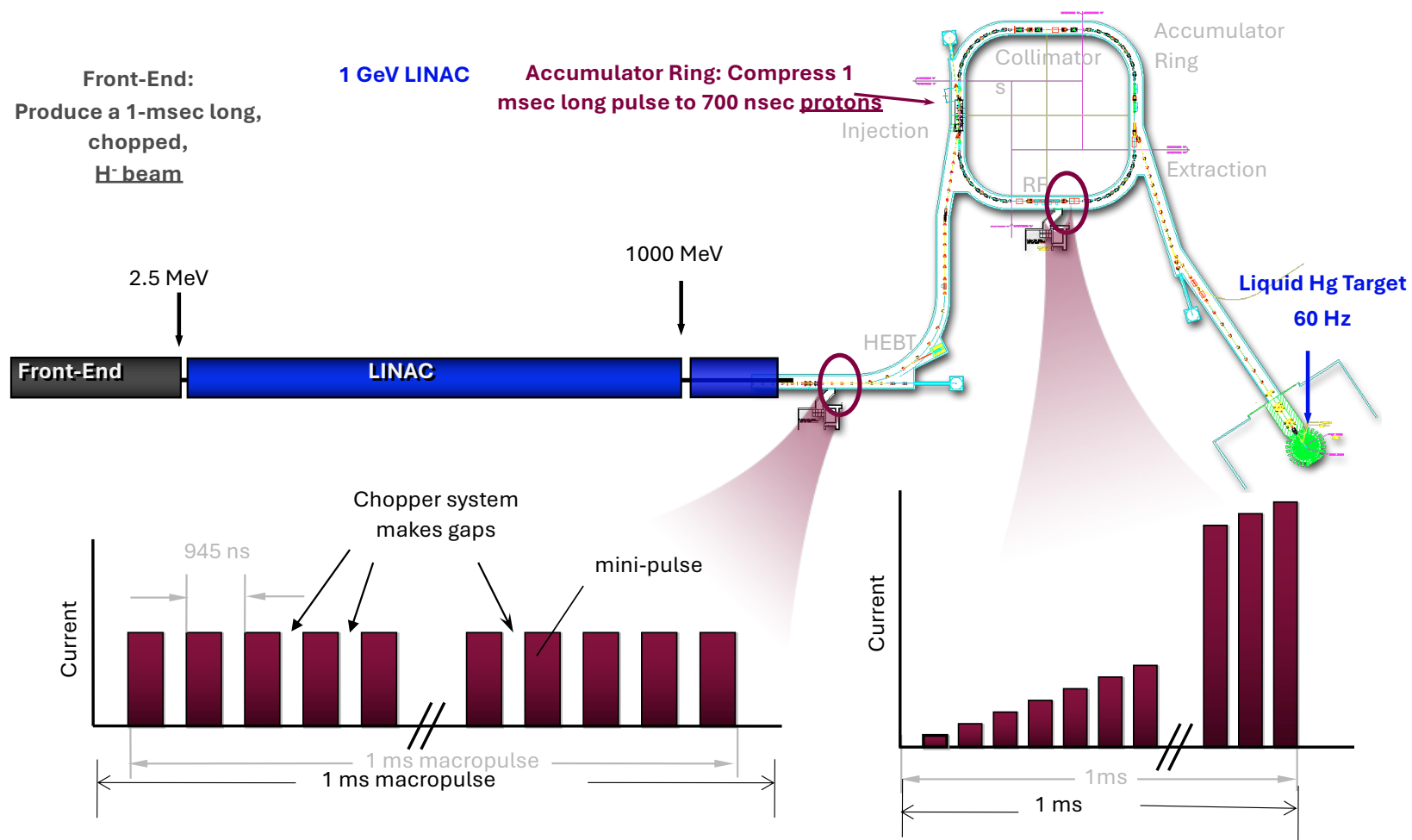

Spallation Neutron Source

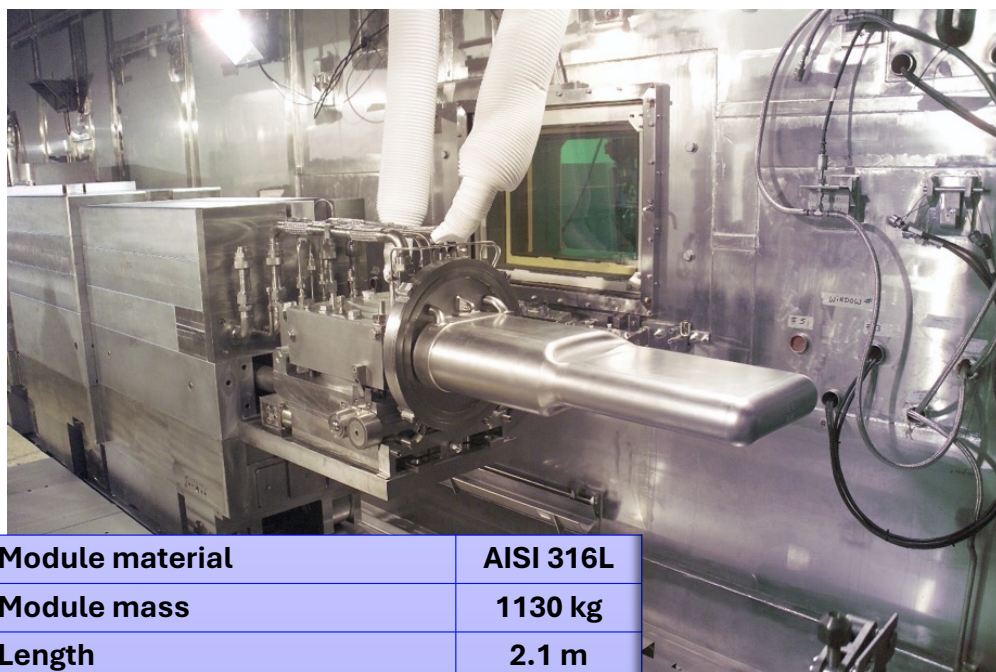

Module material	AISI 316L
Module mass	1130 kg
Length	2.1 m
Mercury mass inside module	794 kg
Mercury mass flow rate	19.4 t/min
Radiation damage limit	12 dpa

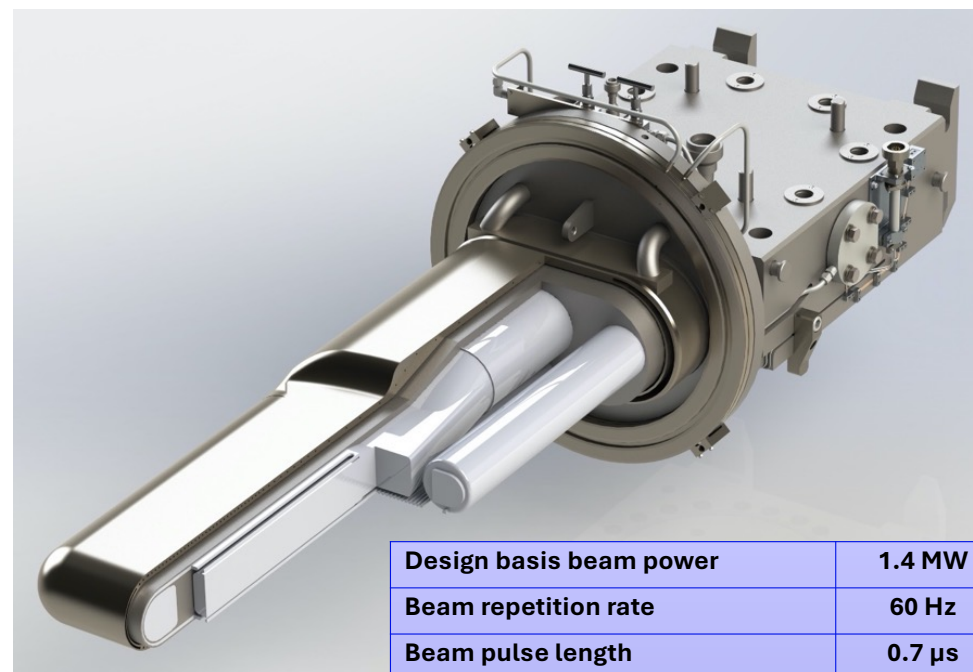

Design basis beam power	1.4 MW
Beam repetition rate	60 Hz
Beam pulse length	0.7 μ s
Energy per pulse	23 kJ
Proton energy	1 GeV

European Spallation Source

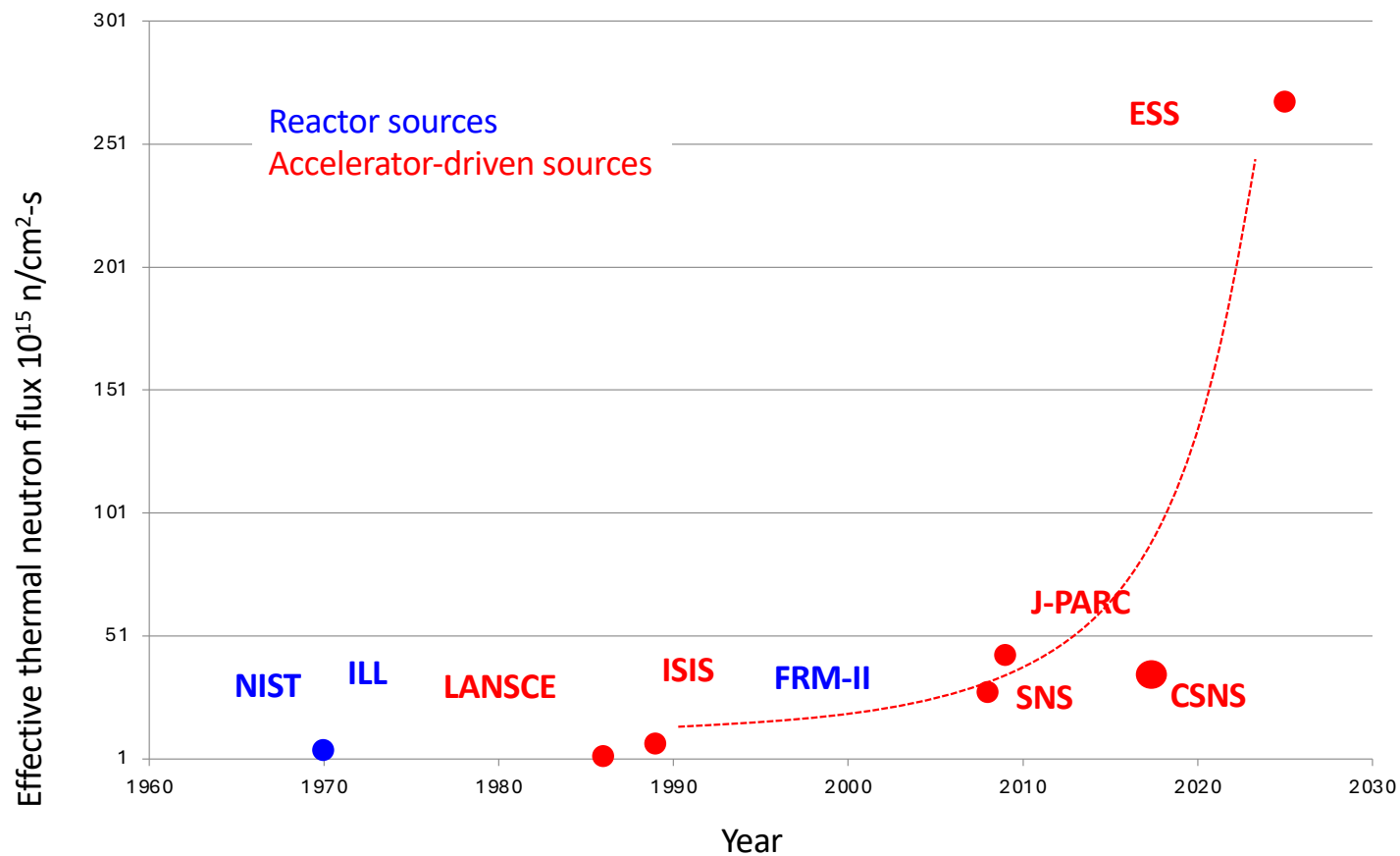

Table of contents



- Neutron sources
 - Neutron reactors
 - Spallation neutron sources
- **Synchrotrons**
- X-ray Free Electron Laser

Synchrotrons





Emittance

The product of the linear source size σ and the beam divergence σ' in the same plane is known as ϵ , the emittance in that plan

$$\epsilon_x = \sigma_x \sigma'_x$$

$$\epsilon_y = \sigma_y \sigma'_y$$

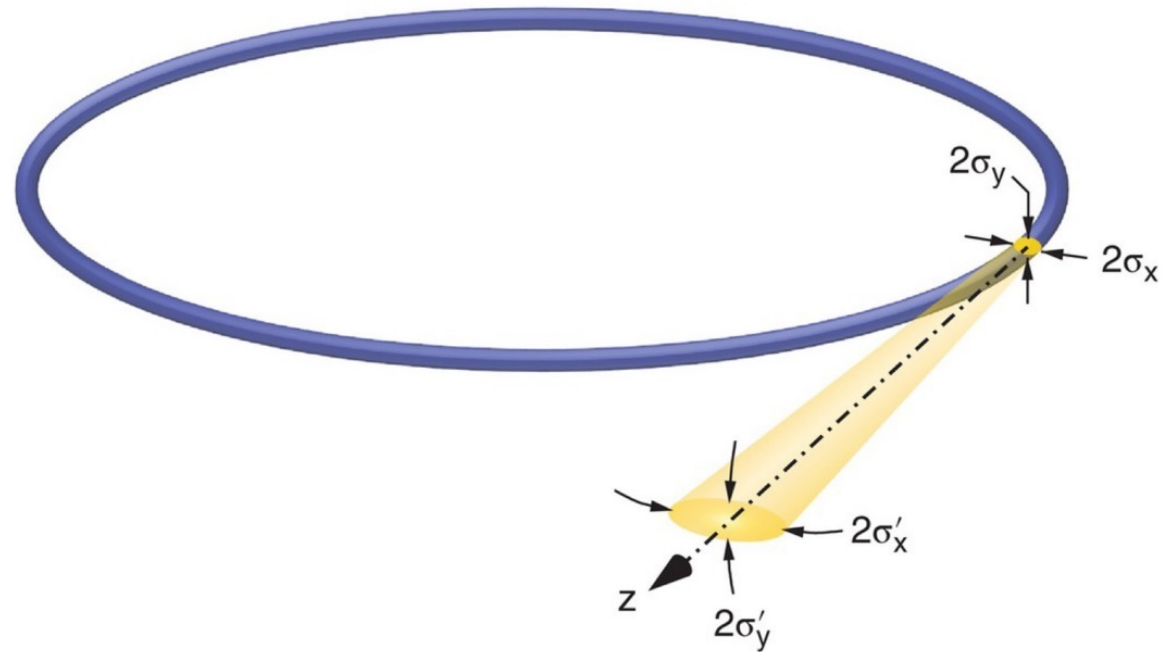

Brilliance

The appropriate figure-of-merit for light sources is the brilliance.

It takes into account:

- the number of photons produced per time unit (use second)
- the angular divergence of the photons (in mrad^2)
- the cross-sectional area of the photon beam (use mm^2)
- the number of photons falling within a certain bandwidth (BW) of the central wavelength (0.1% are customary)

The unit for brilliance is:

$\text{photons} / \text{s} / \text{mm}^2 / \text{mrad}^2 / 0.1\% \text{ (BW)}$

or, flux per total emittance

Brilliance

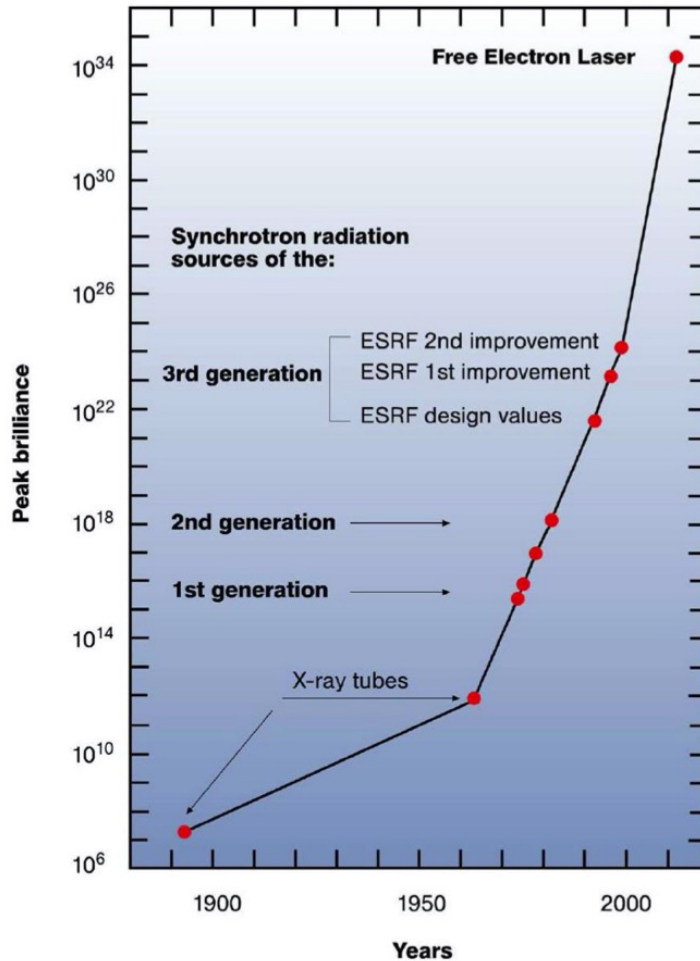

Classification of synchrotron light sources:

- **1st generation:** parasitic use of synchrotrons built for particle physics
- **2nd generation:** dedicated synchrotrons / storage rings built for photon science
- **3rd generation:** dedicated storage rings optimized for operation with insertion devices (wigglers and undulators)
- **4th generation:** diffraction-limited storage rings

Synchrotron layout

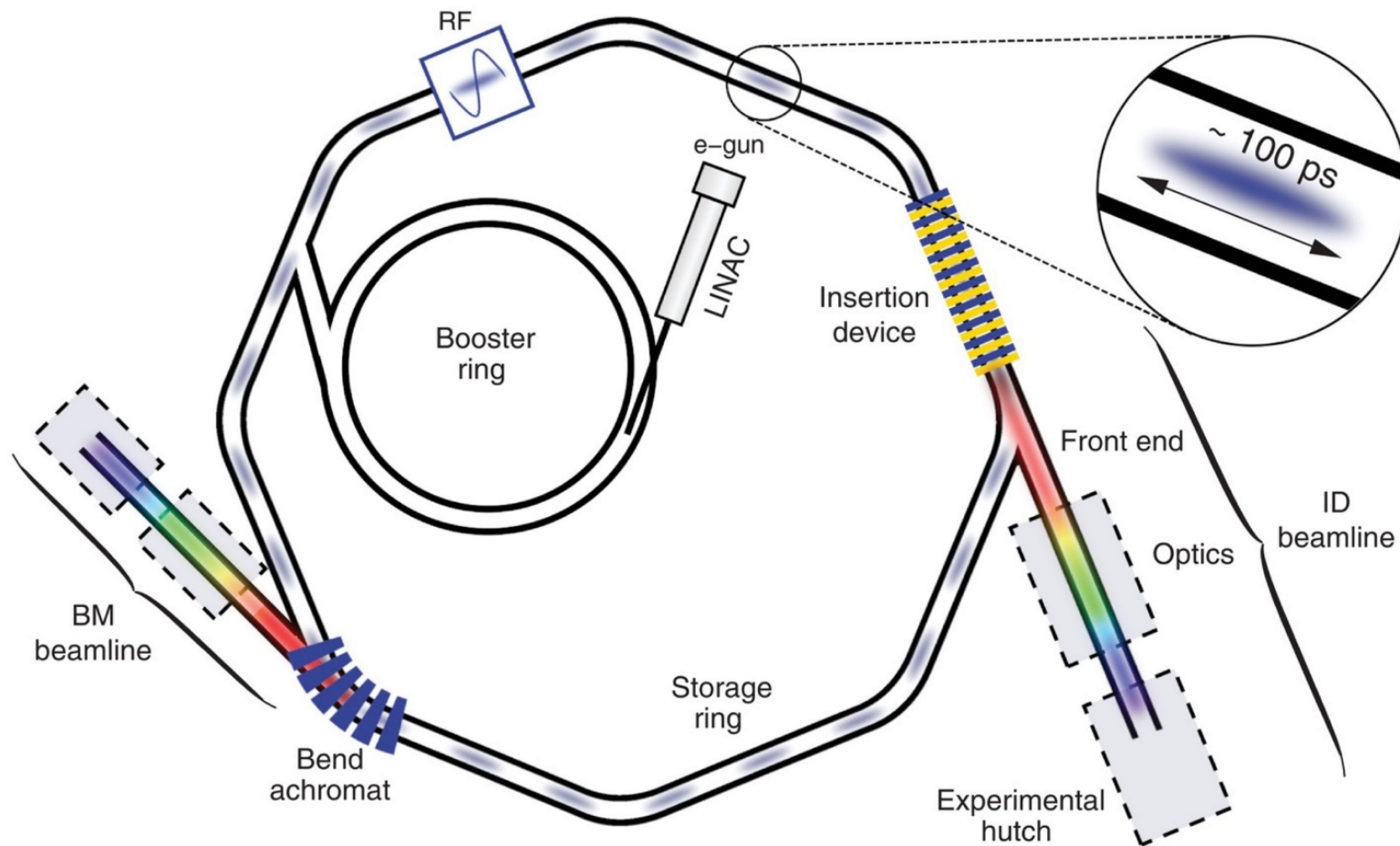

Swiss Light Source

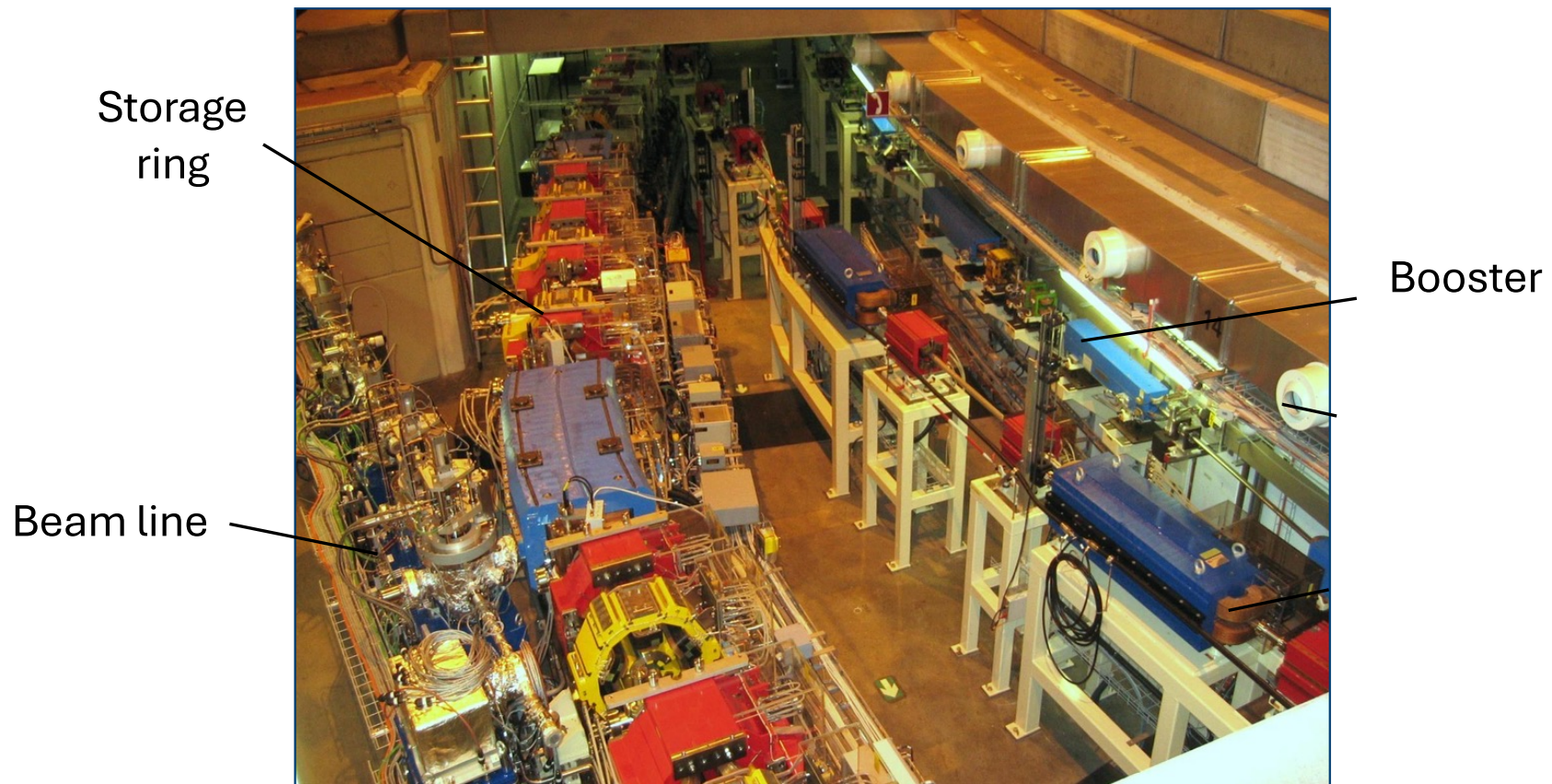

Acceleration

Electrons entering the resonant cavity at the right moment in its voltage cycle are accelerated by the electric field within the cavity generated by the klystron source.

‘Slow’ electrons entering the RF cavity at *A* will be given an extra boost, while ‘fast’ electrons (at *B*) receive less energy.

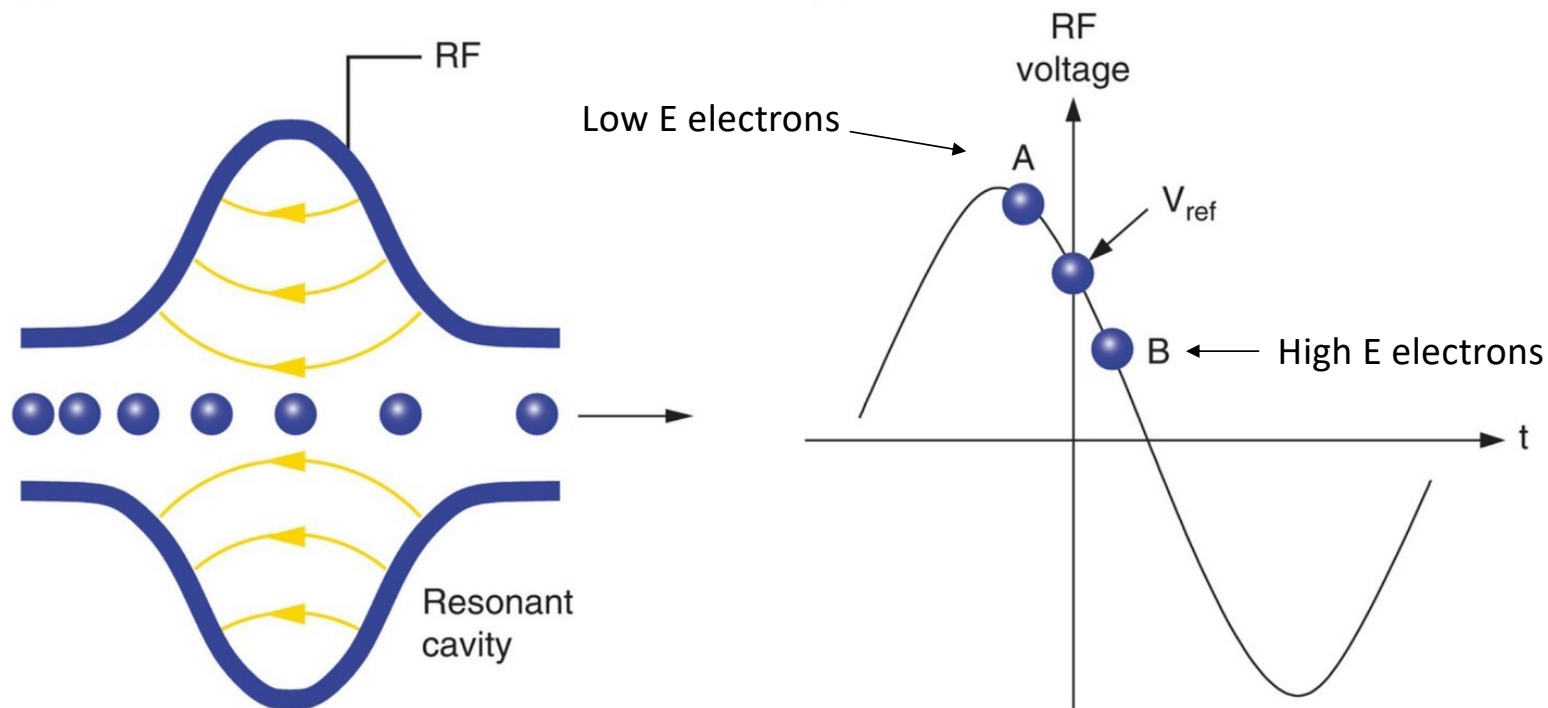

Generation of electromagnetic radiation (EMR)

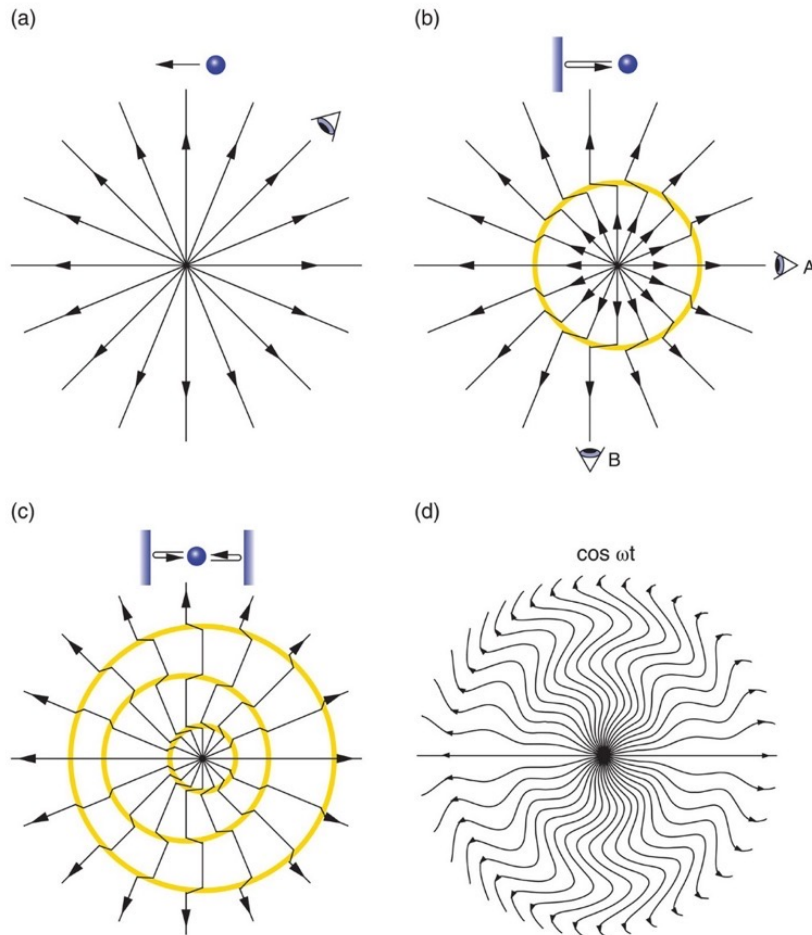

- a) At rest or constant velocity, no component of the field in any transverse direction
- b) Single abrupt acceleration
 - Distortion of electric field lines
 - Amplitude of radiation $\sim \cos \theta$
- c) Multiple abrupt accelerations
 - Set of pulses at regular intervals
 - Multiple frequencies
- d) Simple harmonic
 - Radiation with single frequency

Forces acting on charged particle by EMR

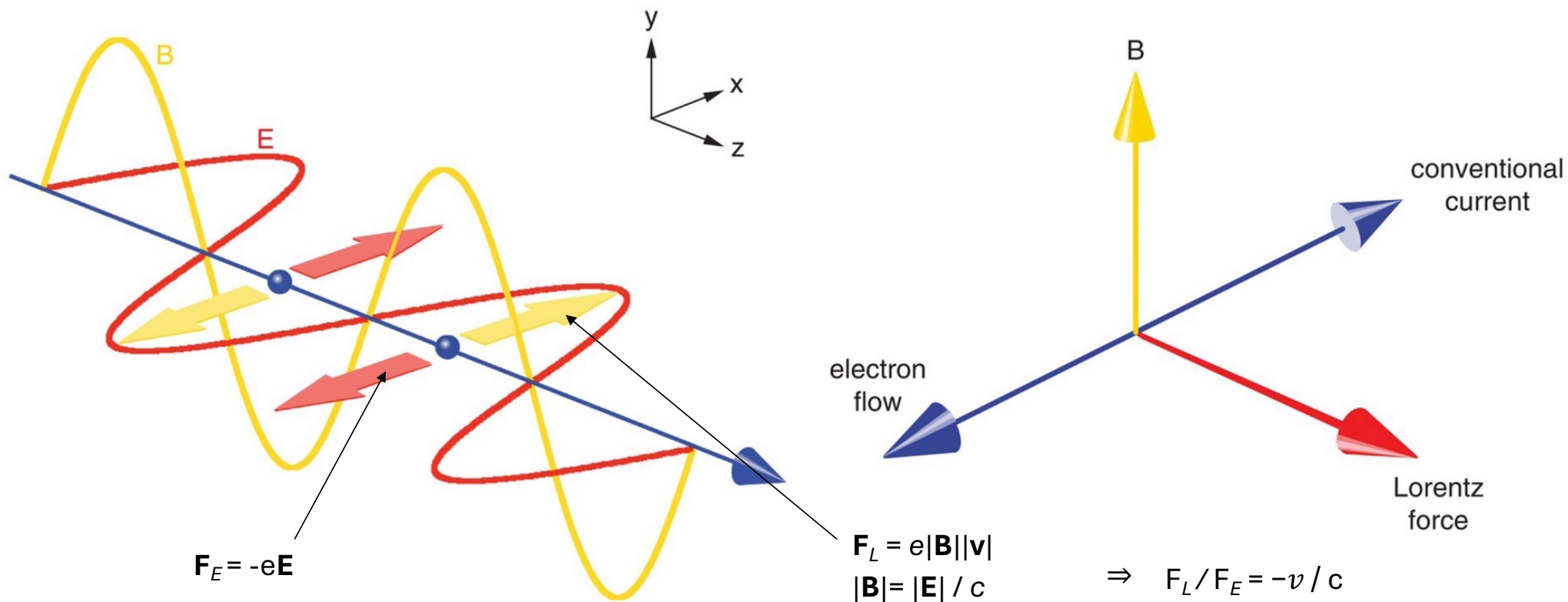

F_L only becomes nonnegligible compared to F_E for electrons travelling at relativistic velocities.

Radiation of an accelerating charged particle

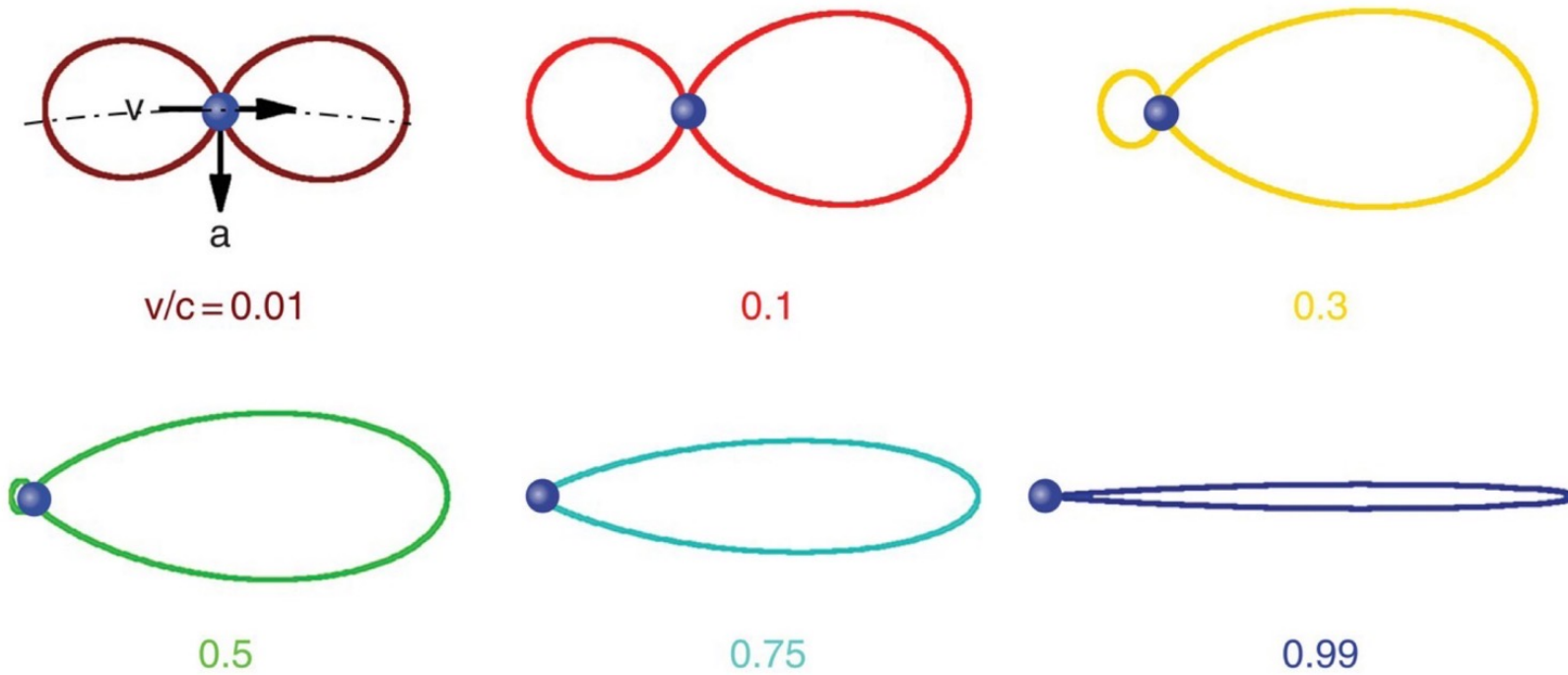

$$P = \frac{2}{3} \frac{e^4 c^3}{(m_e c^2)^4} \mathcal{E}^2 B^2 = 6.763 \times 10^{-18} \mathcal{E}^2 B^2$$

E.g. 3 GeV synchrotron storing a current of $I = 250$ mA and using bending magnets with field strengths of 1.4 T equates to a radiative power output due to circulation of the electrons alone of 186 W.

Bending magnet

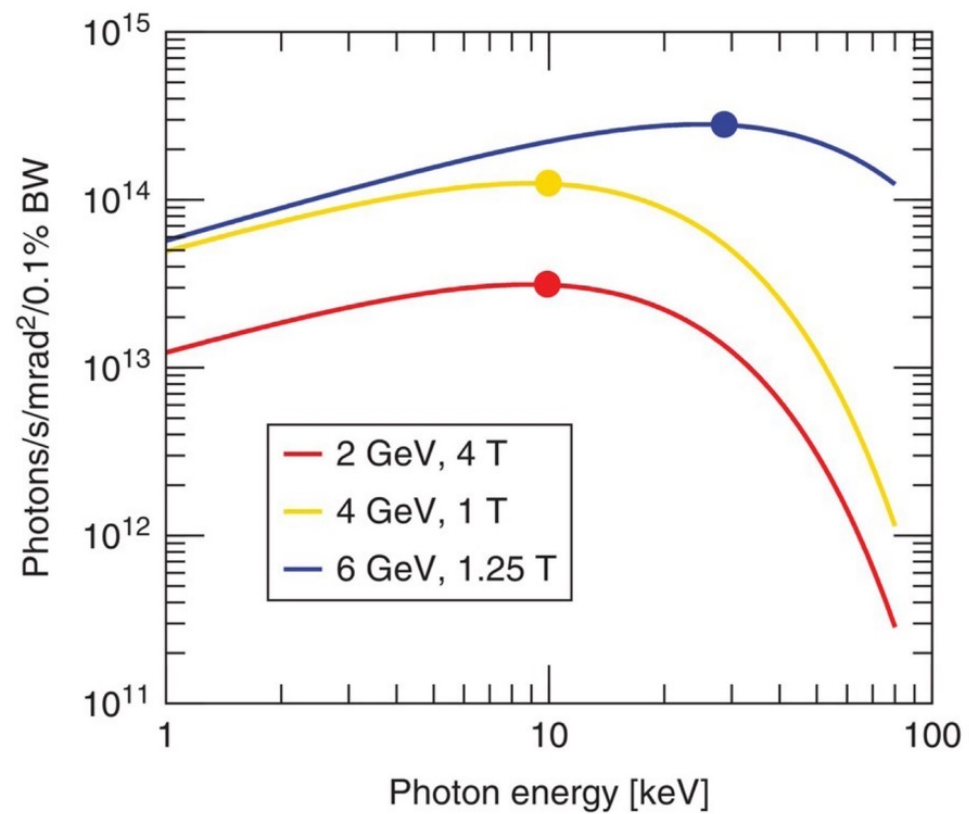
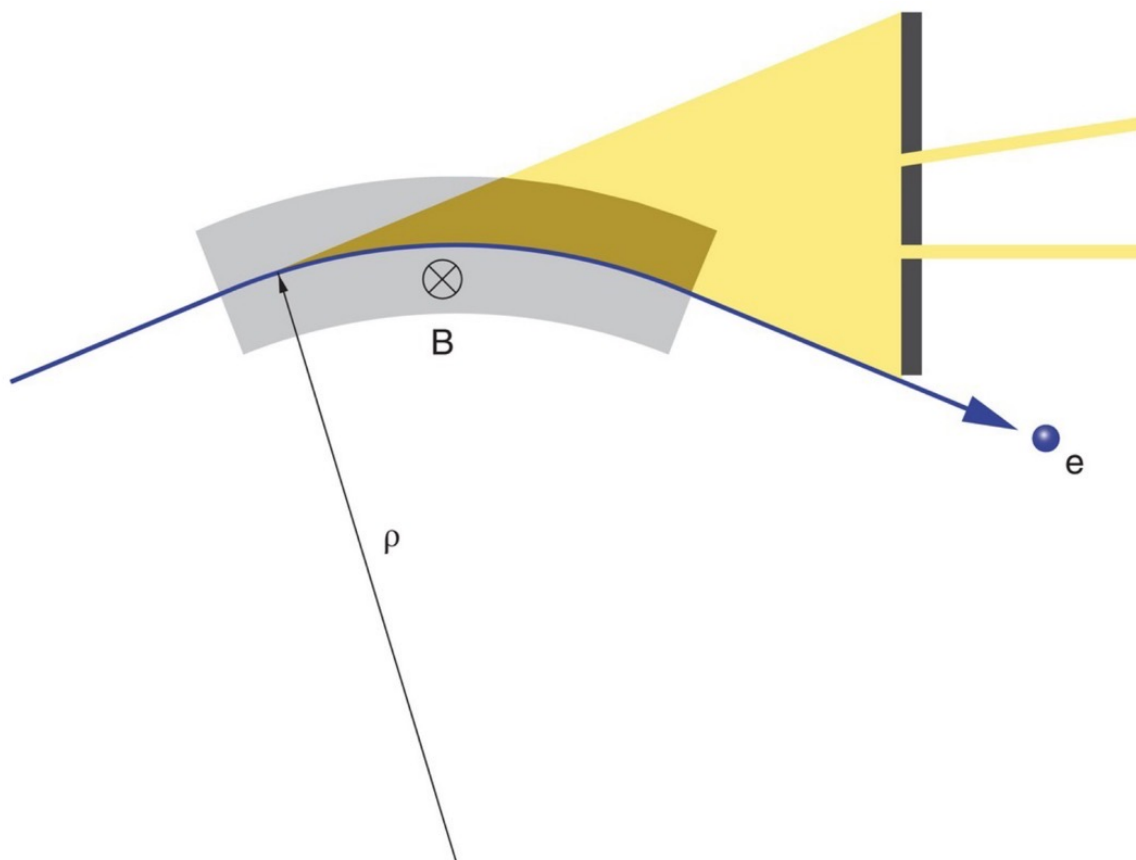

Electron beam path correction

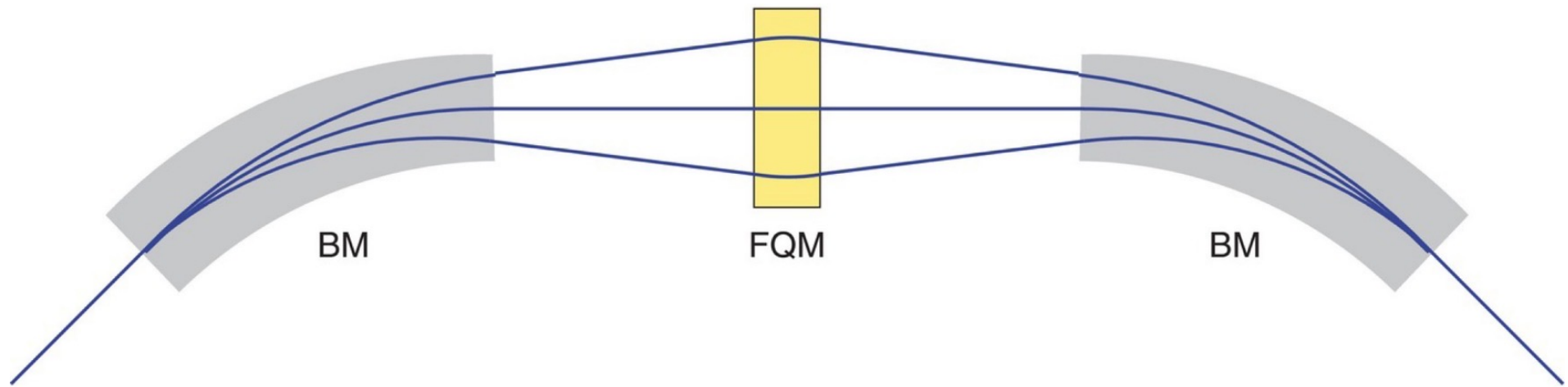

Angular dispersion of electrons of different energies as they pass through a bending magnet and the consequent increase in the electron-beam emittance can be corrected in a double-bend achromat by placing a **focussing quadrupole magnet** (FQM) symmetrically in between two identical dipole bends (BM). Lower-energy electrons are bent through larger angles by the dipoles than are those of higher energy.

Electron beam path correction

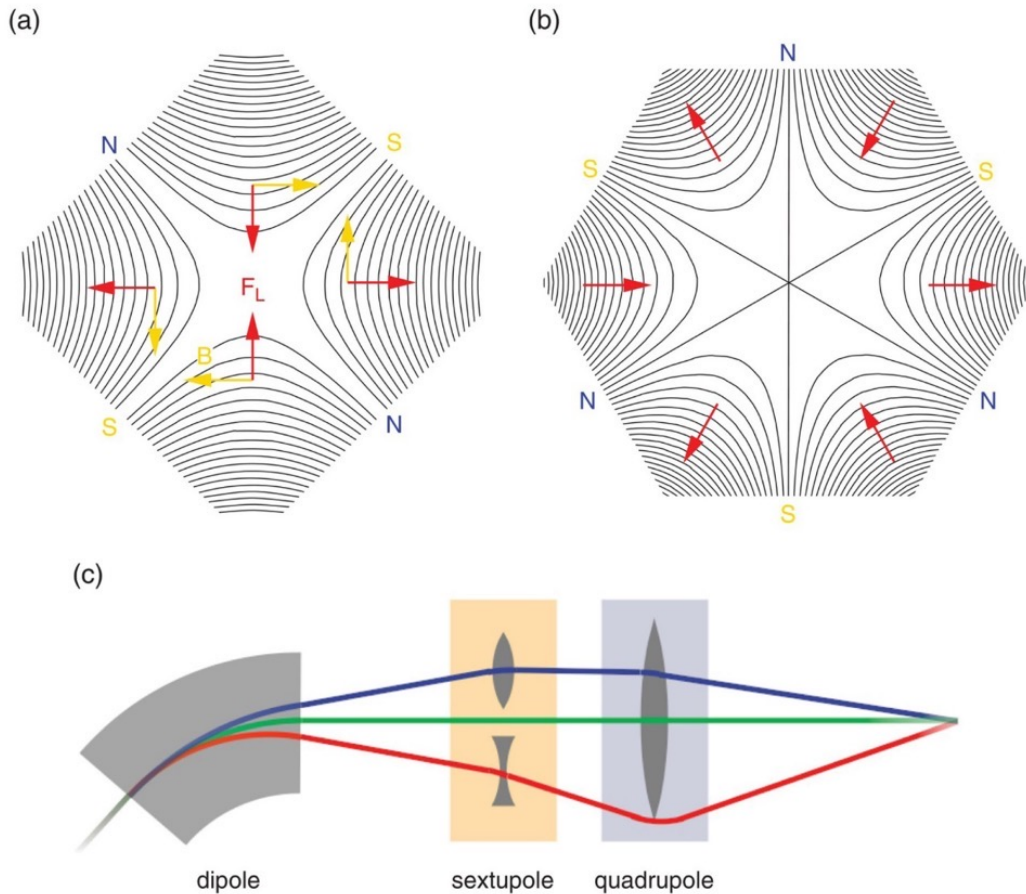

- In a quadrupole the Lorentz forces are such that in one plane (here, vertical) they focus the electron beam, while in the orthogonal plane (here, horizontal), the electrons are defocused. Therefore one could place two quadrupoles subsequently.
- Sextupoles have focal lengths that are inversely proportional to the distance of the electrons from the central axis
- The dispersion of the electrons' energies are sorted for their momentum by the sextupole in the plane perpendicular to its axis, which corrects for the quadrupole chromatic focussing error.

Magnetic lattice

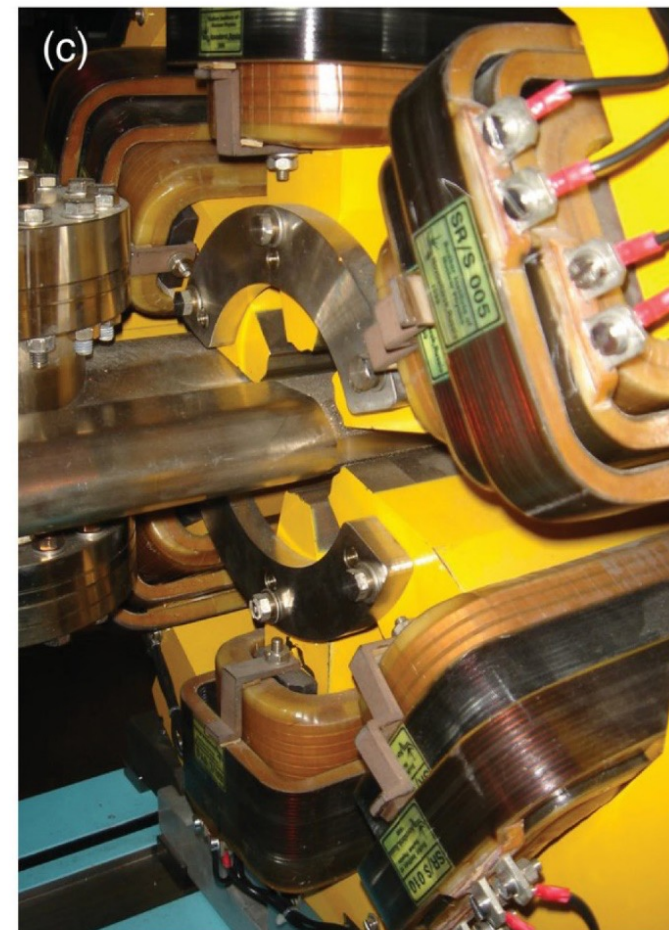
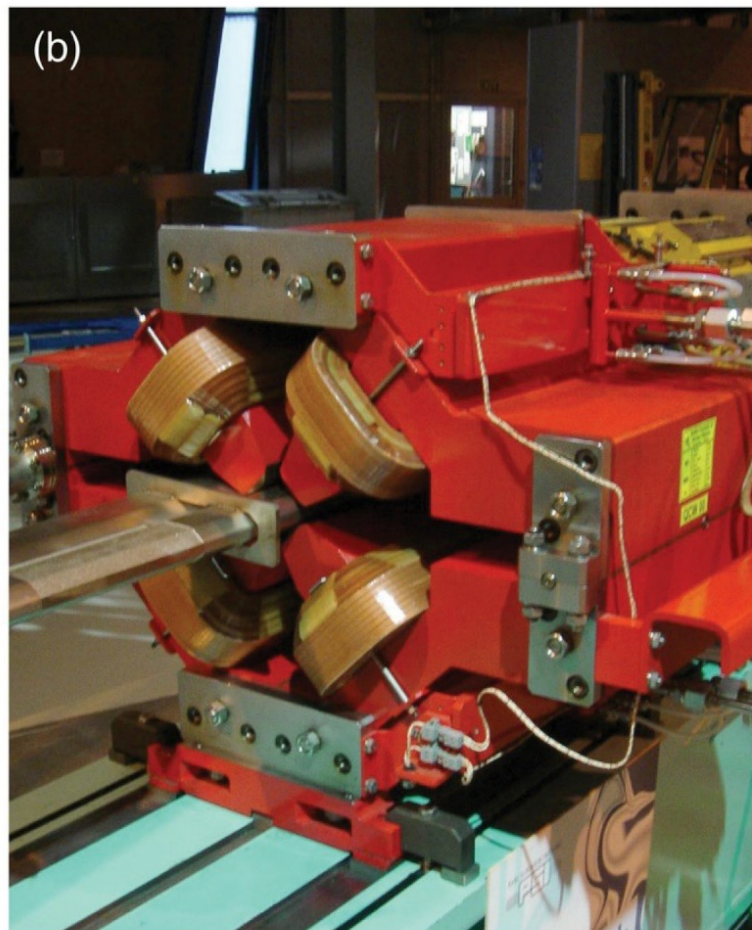
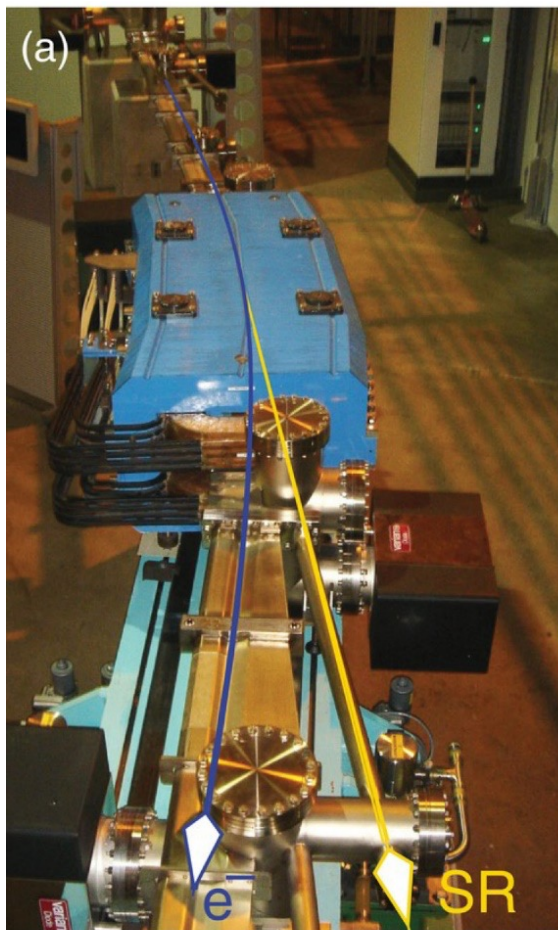

Insertion devices

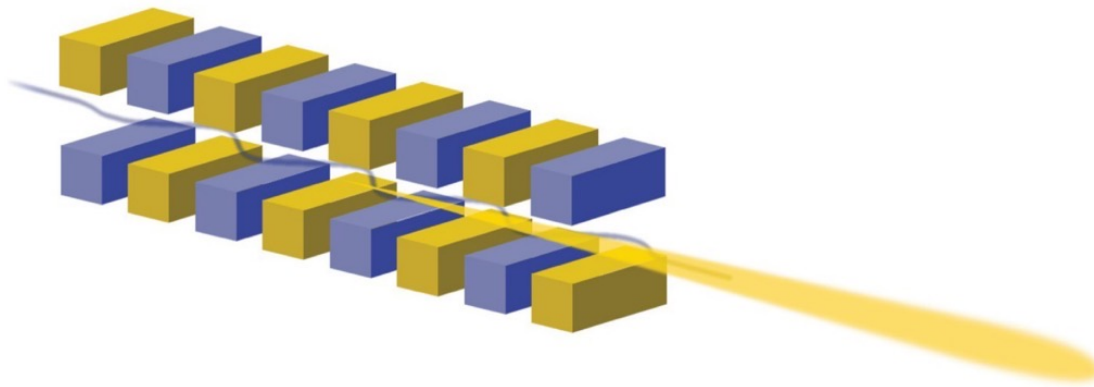

The lower magnet array of a U15 (15 mm period) undulator.

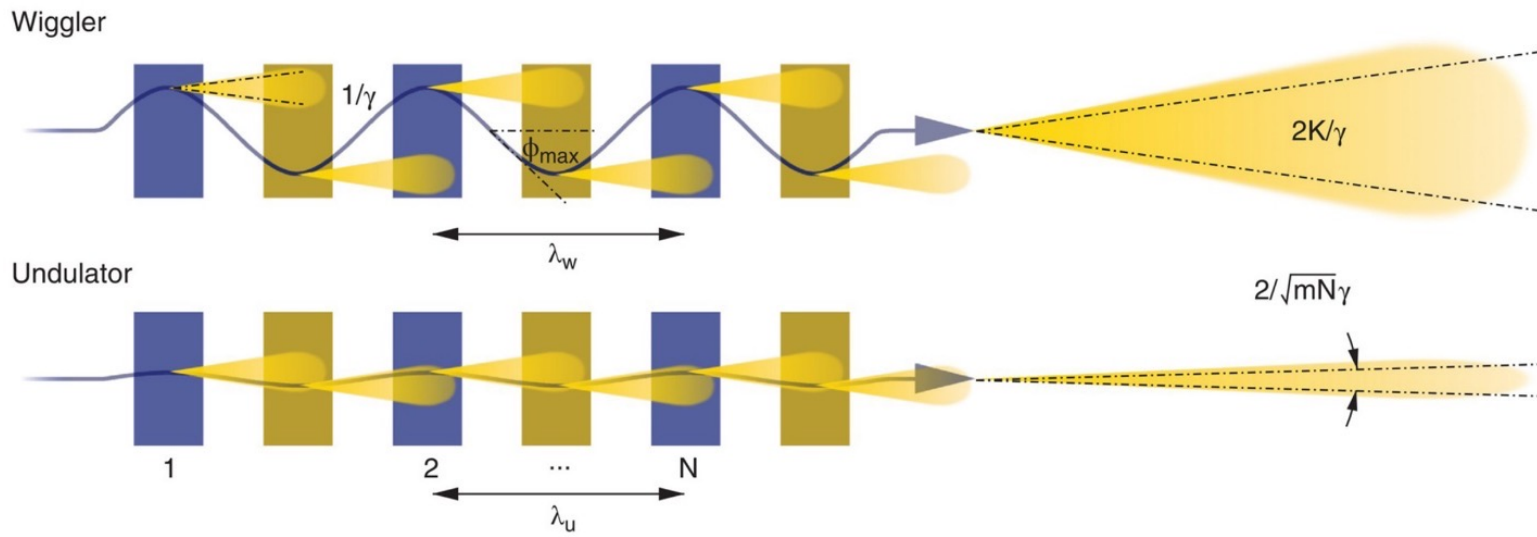

Undulator

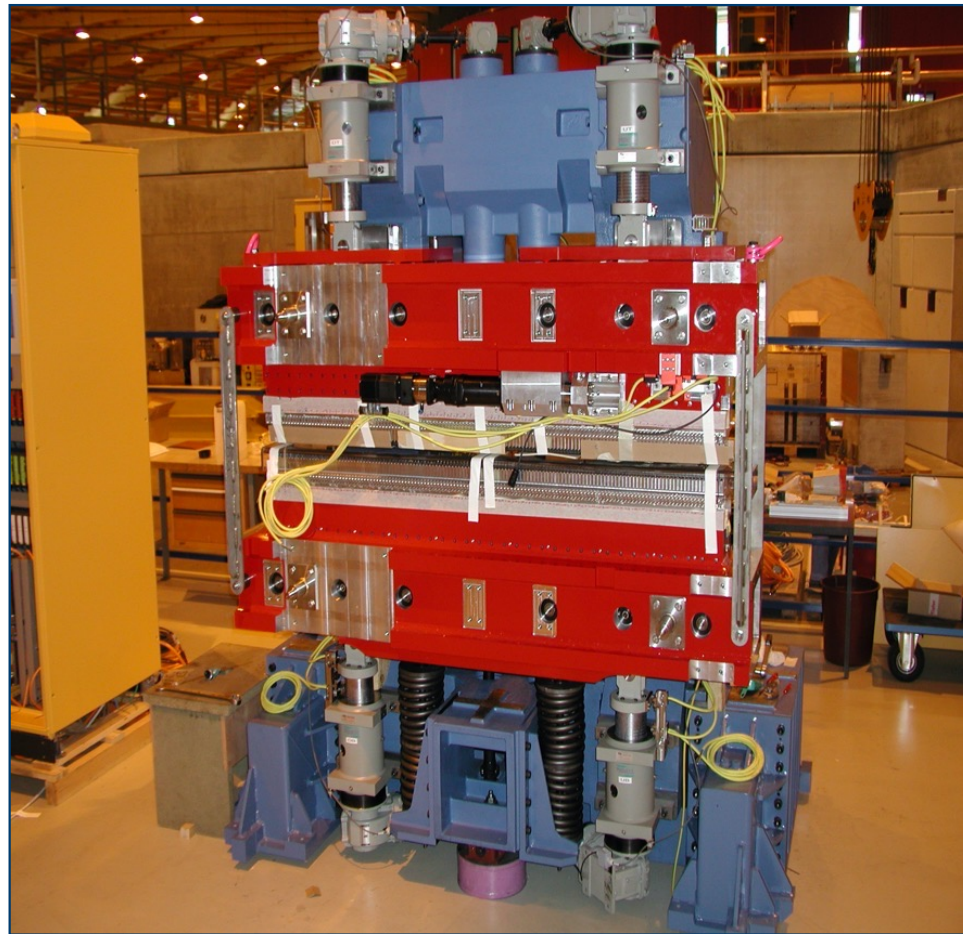

Permanent magnets:
62 periods à 56mm

Undulators

Constructive interference between electromagnetic wavefronts emanating from equivalent points on the undulations occurs when their separation is an integer multiple of the radiation wavelength. The curved path S taken by the electron travelling at the relativistic velocity v between A and B is highlighted in blue

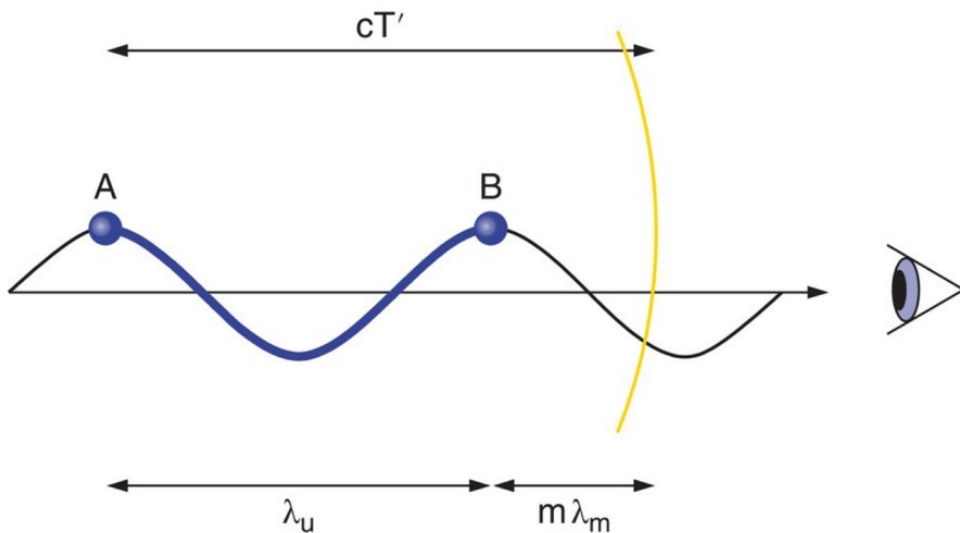

$$m\lambda_m = cT' - \lambda_u$$

$$\Delta E = \frac{2hc\gamma^2}{\lambda_u(1 + K^2/2)}$$

$$\phi_{\max} = K/\gamma$$

γ is the relativistic Lorentz factor

λ_u undulator spatial period

K magnetic deflection parameter

ϕ_{\max} = maximum angular deviation of electron oscillations

Comparison insertion devices

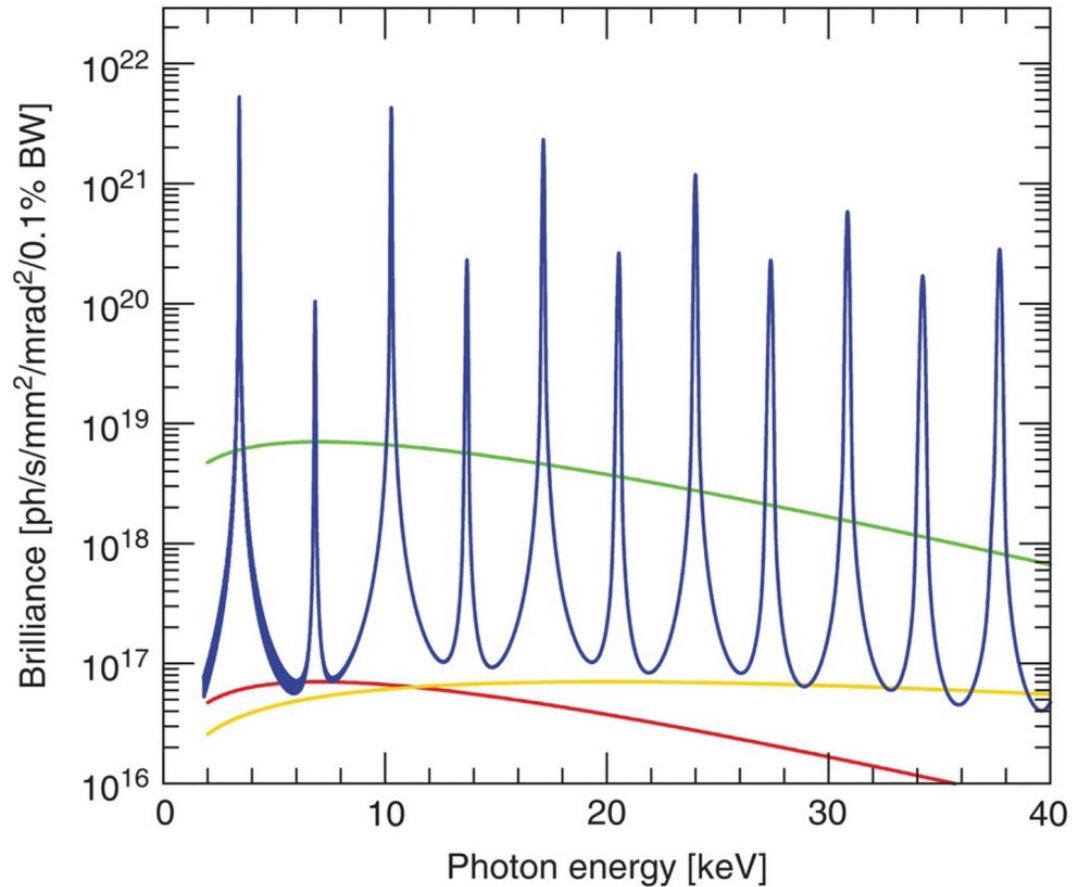

Comparison of brilliances at a 3 GeV DLSR running at 400 mA between a U14 undulator with $K = 1.6$ (blue), a bending magnet with $B = 1.41$ T (red), a superbend with $B = 4$ T (yellow), and a wiggler with the same field strength as the bending magnet and 100 periods (green).

Diffraction limited storage rings

Technological improvements in magnetic lattice technology has led to so-called diffraction limited storage rings (DLSR).

DLSR have 40x smaller horizontal emittance

- In third-generation facilities, the horizontal electron-beam width is, at approximately 100 μm , two orders of magnitude larger than the oscillation amplitude A ($\sim 1 \mu\text{m}$)
- In DLSR the horizontal electron-beam width is of the order of 10 μm .

Enhanced brilliance at spectral peaks

'Cleaner' energy spectra

Diffraction limited storage rings

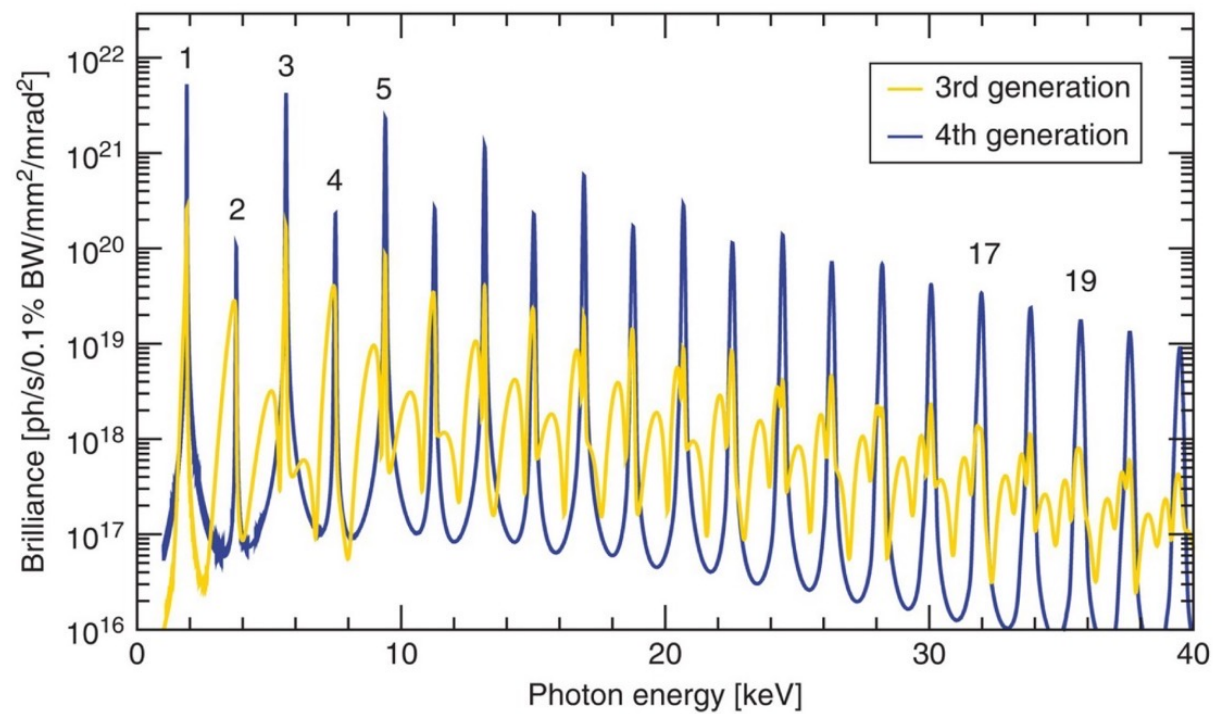
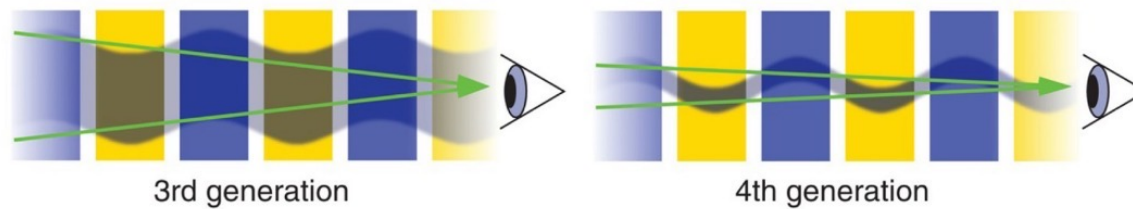

Polarization

Viewed in the electrons' orbital plane, the polarization of the radiation is linear in that plane, as the electrons appear to oscillate in the horizontal plane.

If the observer is above the plane of the storage ring, the electrons will appear to execute an elliptical orbit in a clockwise direction. This angular momentum from the observer's frame of reference is transferred to the emitted photons, which are left-circularly polarized

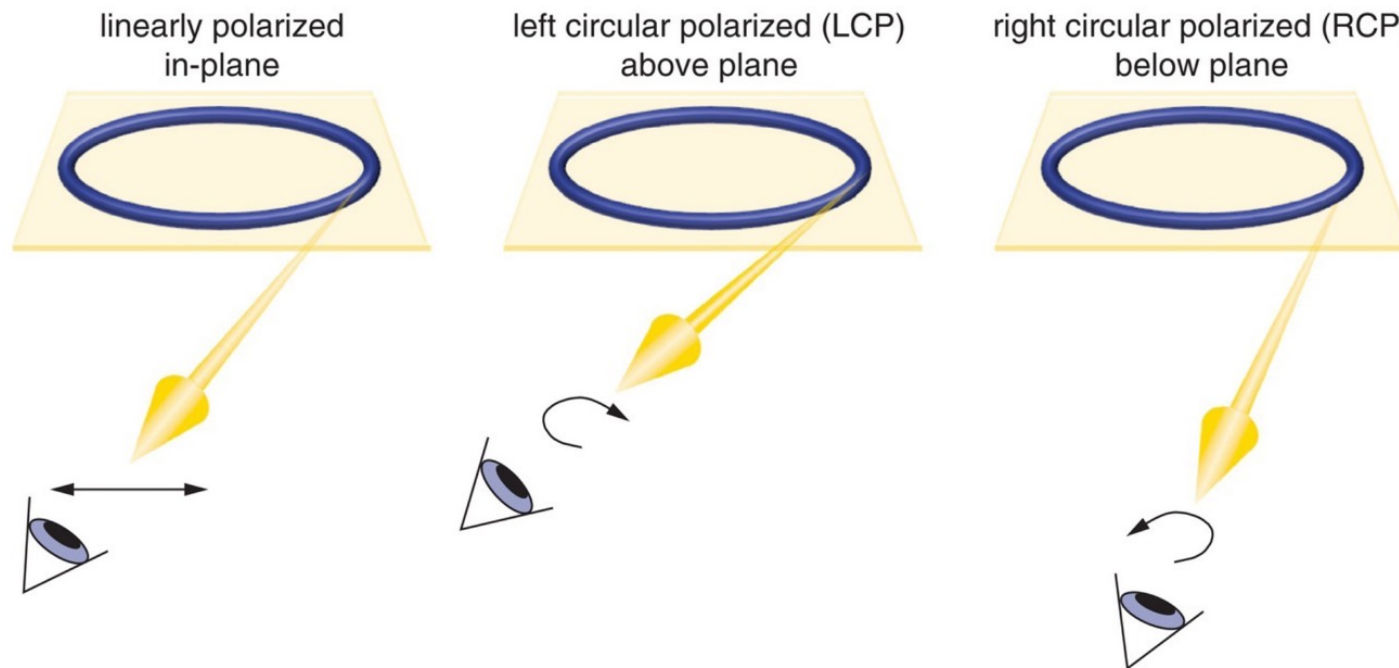

Synchrotrons around the world



lightsources.org/lightsources-of-the-world

Synchrotrons around the world

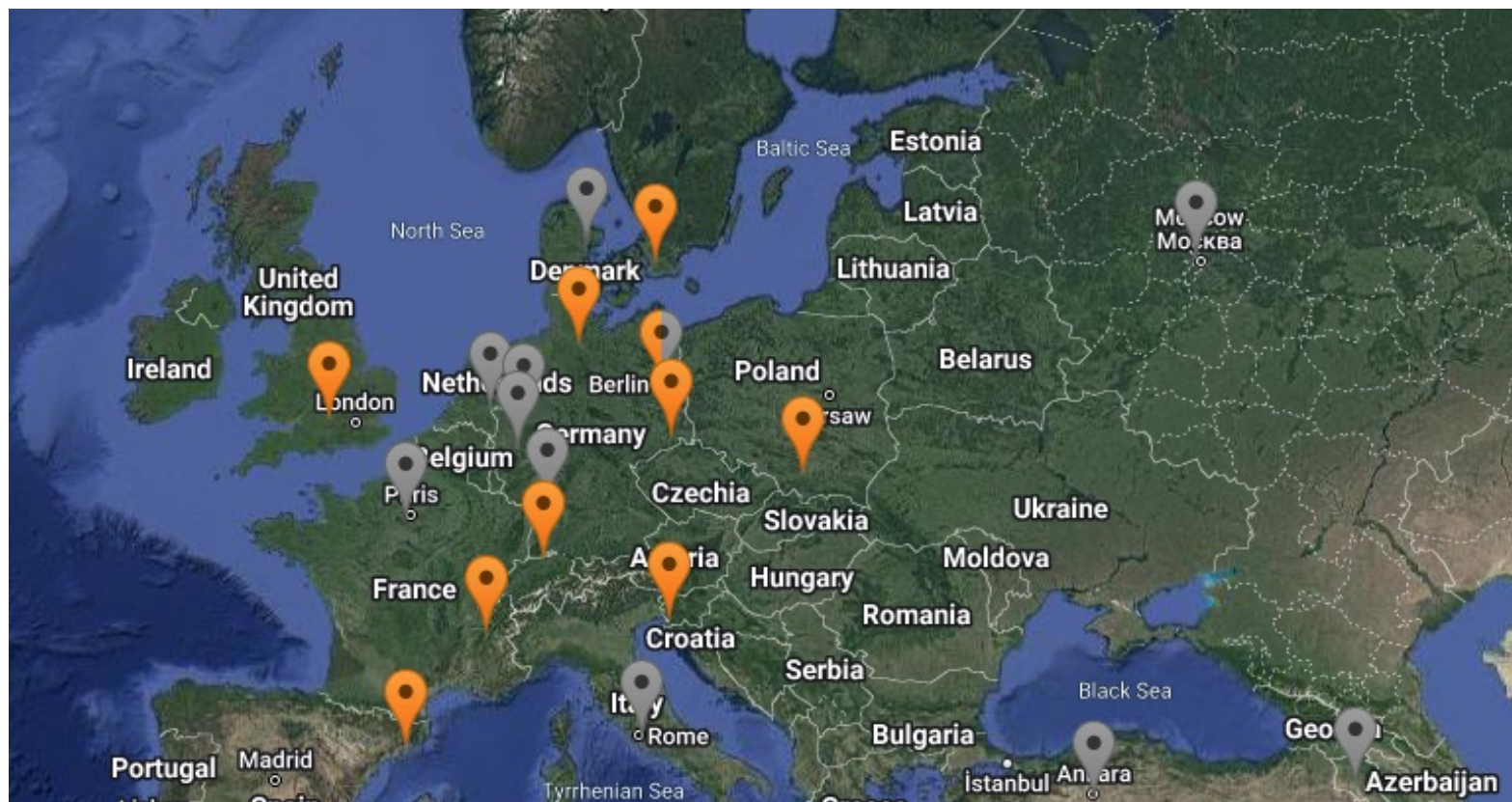

lightsources.org/lightsources-of-the-world

Table of contents

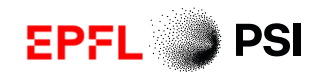

- Neutron sources
 - Neutron reactors
 - Spallation neutron sources
- Synchrotrons
- **X-ray Free Electron Laser**

X-ray free electron lasers

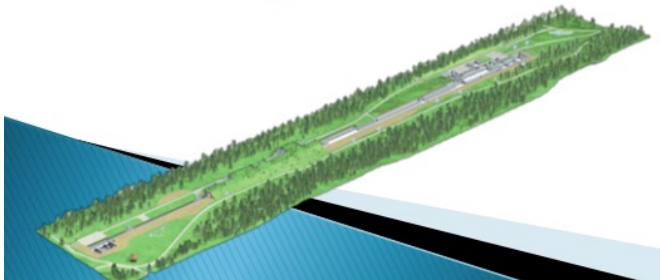

Optical short pulse lasers

Pulse duration: +++ (~fs)

Wavelength: - - - (~800 nm)

- Fastest processes can be analyzed
- Spatial resolution limited

Synchrotrons

Pulse duration: o (~ps)

Wavelength: +++ (~ 0.1 nm)

- Temporal resolution limited
- Wavelength allows for atomic resolution

X-ray free-electron lasers

Pulse duration: +++ (~fs)

Wavelength: +++ (~ 0.1 nm)

- Fastest processes can be analyzed
- Wavelength allows for atomic resolution

X-ray free electron lasers

	Optical lasers	Synchrotrons	FELs
Time atomic res.	Yes	No	Yes
Spatial atomic res.	No	Yes	Yes
Pulse energy	few mJ	< nJ	few mJ
Rep rate	< 0.1 MHz	~500 MHz	~0.1 – 1 MHz
Facility cost	Moderate (≥ 10 MEUR)	High (≥ 100 MEUR) (but government funded)	Very High (≥ 300 MEUR) (but government funded)
User accessibility	Poor, normally buy it yourself!	Good: ~50 user facilities worldwide (<50 beamlines each)	Fair: ~5 user facilities worldwide (<10 beamlines each)

XFEL around the world

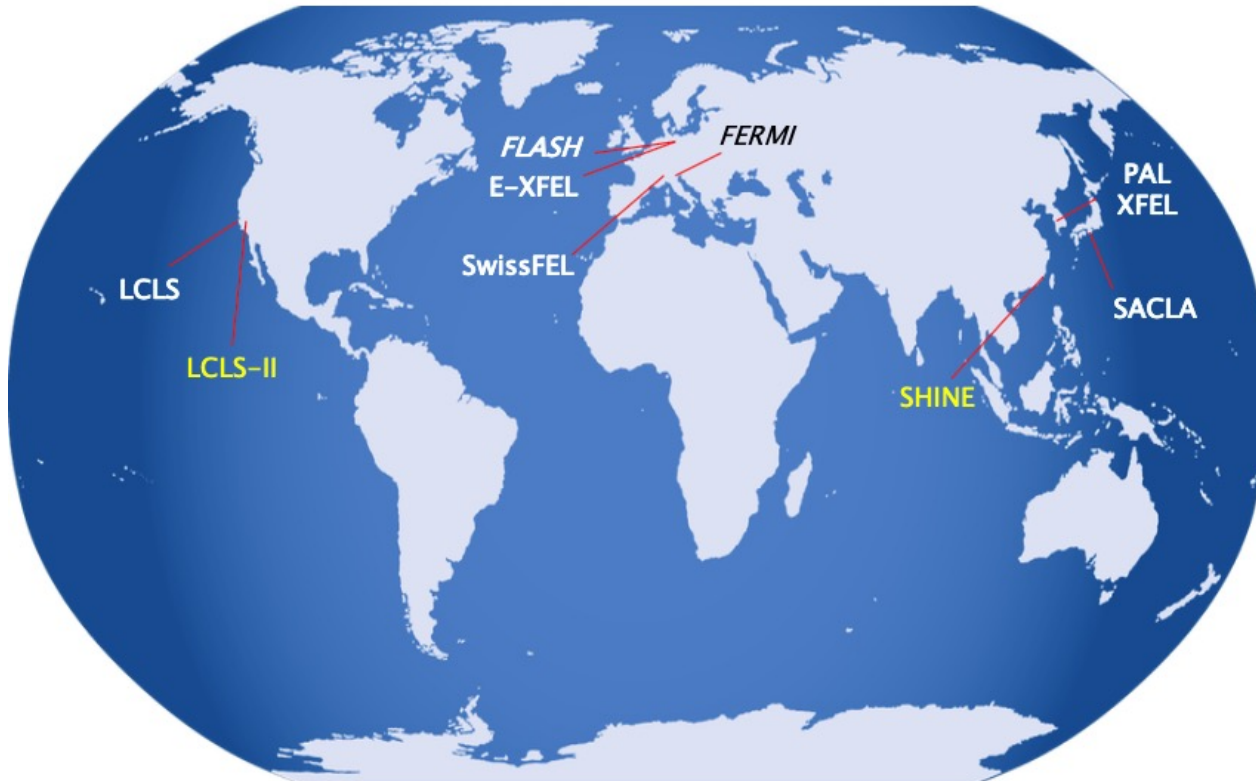

- **FLASH**: first soft X- ray with high repetition rate (MHz), 2007
- **LCLS**: first hard X- ray, 2009
- **SACLA**: compact hard X-ray, 2011
- **FERMI**: first soft X- ray seeded-FEL, 2013
- **PAL-XFEL**: hard X- ray with low (20 fs) timing jitter, 2016
- **E-XFEL**: hard X-ray with high repetition rate, 2017
- **SwissFEL**: compact hard X-ray driven by low emittance beam, 2017
- **Future facilities**: LCLS2 and SHINE (high repetition rate)

XFEL around the world

	LCLS	SACLA	PAL-XFEL	E-XFEL	SwissFEL
Country	USA	Japan	Korea	Germany	Switzerland
Starting oper. year	2009	2010	2017	2017	2018
Energy (GeV)	14.3	8.5	10	17.5	5.8
Length (km)	3.0	0.75	1.1	3.4	0.74
Construction cost (M\$)	415	370	400	1600	280
Pulses per second	120	60	60	27000	100
Emittance (nm)	400	1000	550	<600	200

Schematic XFEL

- Electron bunches are emitted from a low-emittance gun (LEG) irradiated by picosecond laser pulses. They are then accelerated in a short LINAC (LINAC 1), compressed longitudinally using one or more bunch-compressor magnet chicanes (BC), then further accelerated using a much longer LINAC (LINAC 2) before entering a long undulator, typically a few hundred metres in length.
- The SASE process along the undulator produces highly intense x-ray pulses with durations of the order of 50 fs.
- The electrons are deflected after the undulator using a bending magnet and subsequently dumped.

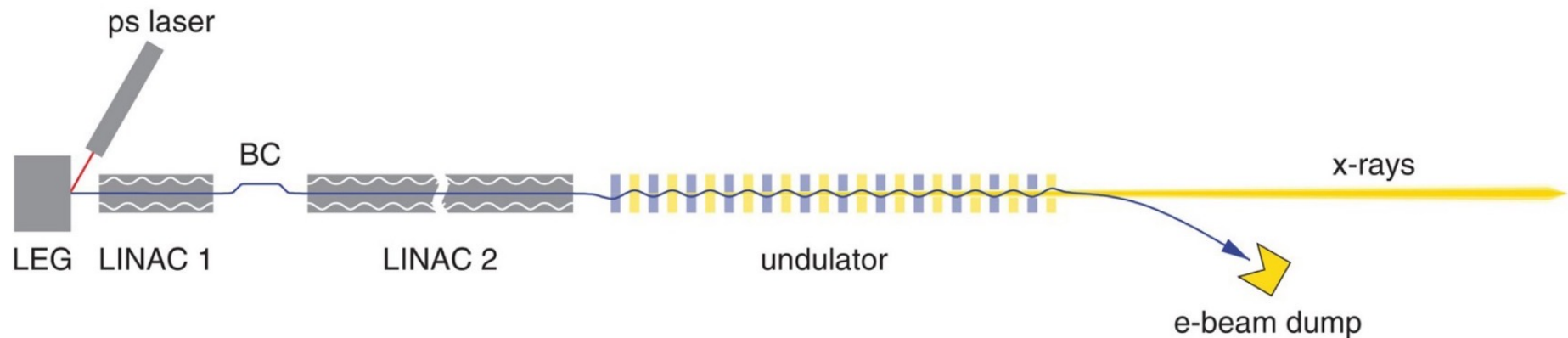

Electron gun

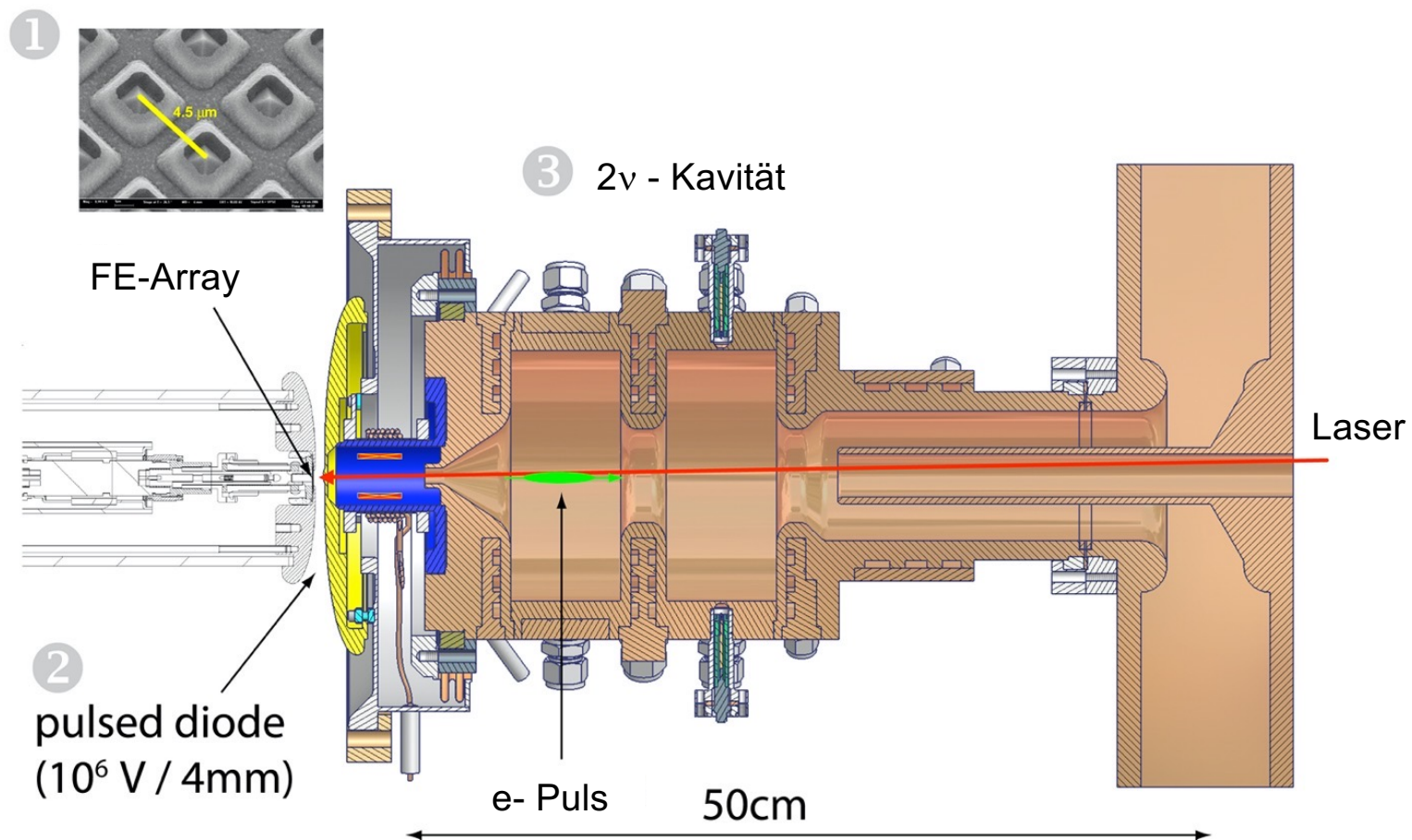

Bunch compression

- Leading electrons are accelerated less than those electrons towards the back of the bunch (this phenomenon is referred to as 'chirping')
- Compression is achieved by allowing an electron bunch to pass through a four-dipole chicane, whereby the faster electrons catch up with the slower electrons at the front, thanks to the shorter path they execute.

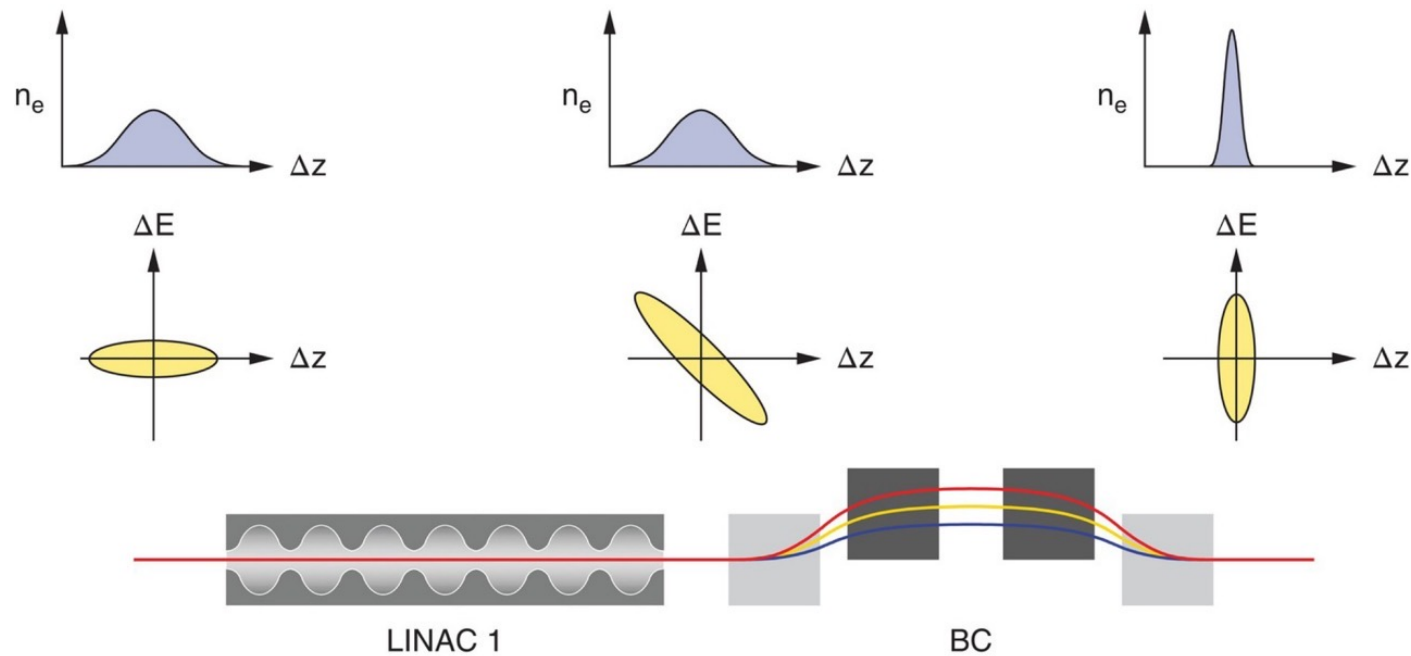

Brilliance

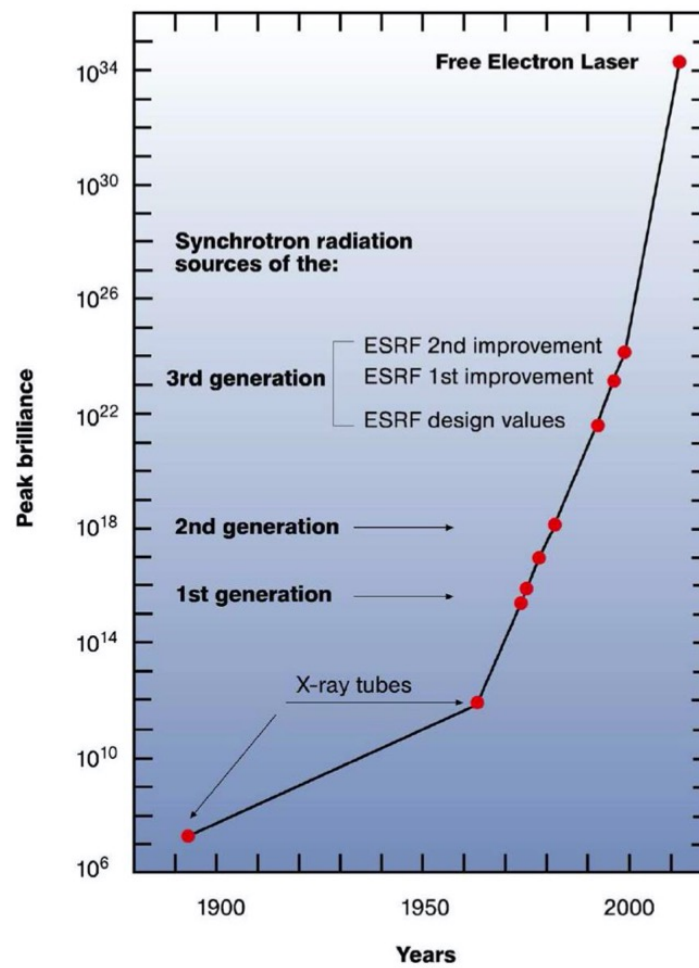

The SASE process

- Self-amplified spontaneous emission
- A typical synchrotron undulator may have a source size of $100 \times 10 \mu\text{m}^2$, and generate bunches of 50 ps duration containing 5×10^6 1 \AA photons. This equates to an areal power density of the order of $1.6 \times 10^{11} \text{ W m}^{-2}$, and an electric-field amplitude $E^0 \approx 10^7 \text{ V m}^{-1}$, and $B_0 \approx 40 \text{ mT}$, nearly two orders of magnitude smaller than that imposed by the undulator's magnet array. We can thus conclude that, *in a conventional third-generation facility, the impact of the electromagnetic field generated by undulator radiation on the electrons' trajectory is completely negligible.*
- In the case of XFELs, however, the beam is tailored to have as low an emittance and as high an electron density as possible, through the low-emittance gun and bunch compression

The SASE process

- Magnetic field of the emitted electromagnetic radiation always lies perpendicular to the electrons' trajectory -> no transfer of energy
- Difference in length between the path executed by the electron through a single undulator period and that of the electromagnetic field is a single wavelength
- Velocity along x (v_x) opposite to electric field -> deceleration the electron
- Velocity along x (v_x) in the same direction as electric field -> acceleration the electron
- This causes spatial redistribution of the electrons within the wavelength of the emitted radiation, causing microbunching

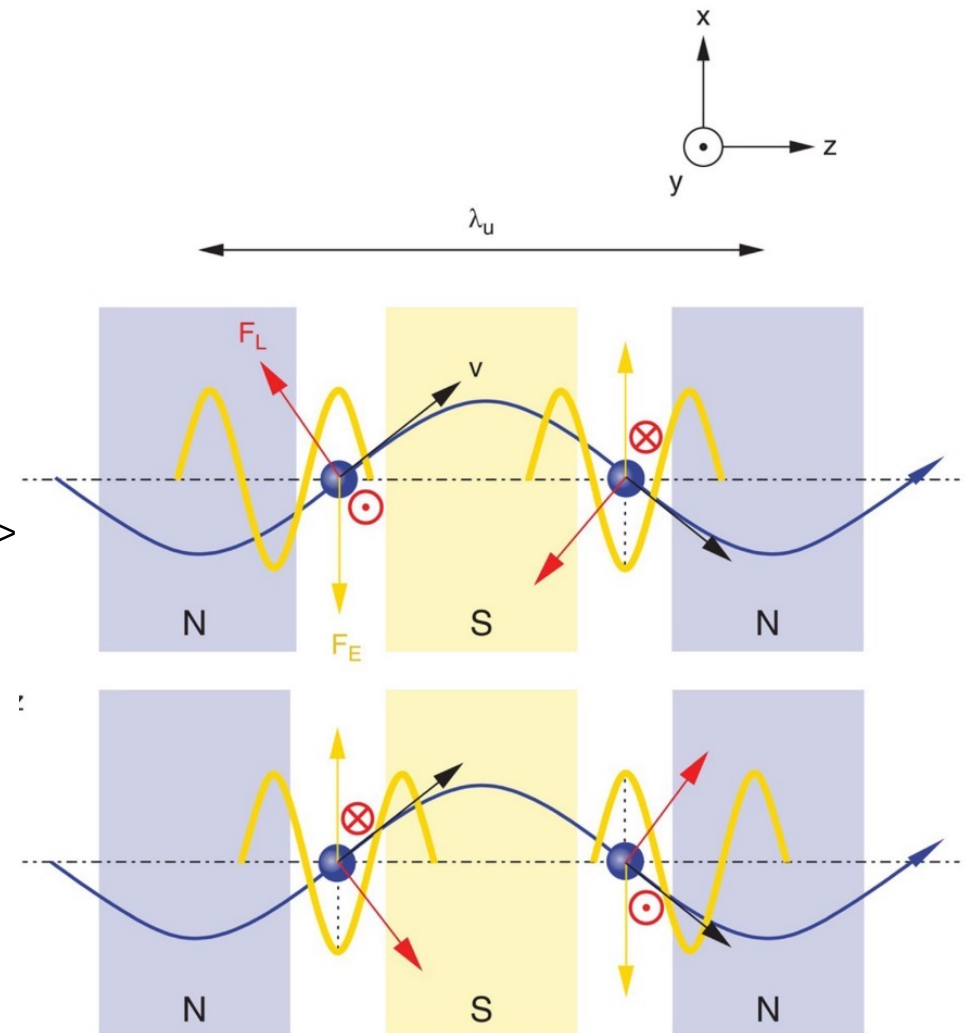

The SASE process

- If the positions of the electrons bear no correlation to the radiation they emit, the phases of that radiation are likewise random. Their summed amplitude is equal to the amplitude of the radiation emitted from one electron multiplied by the square root of the number of electrons in the bunch.
- If emission from all electrons are in phase. The amplitudes of the radiation from each of the n_e electrons add linearly, resulting in an increase in intensity by n_e^2 .

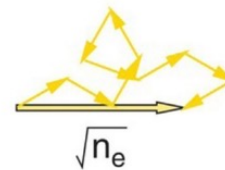
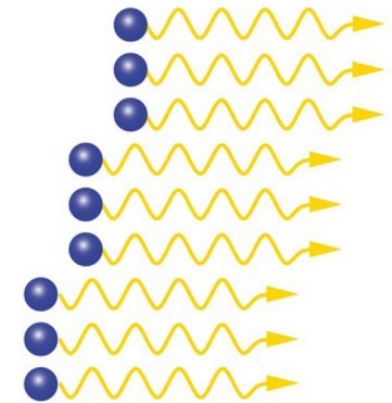
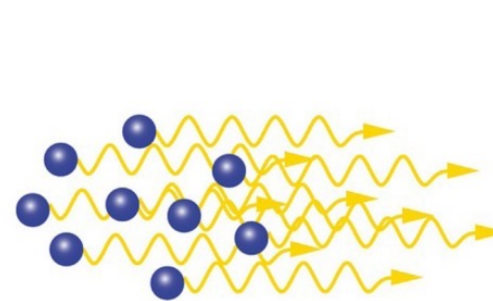

incoherent bunch

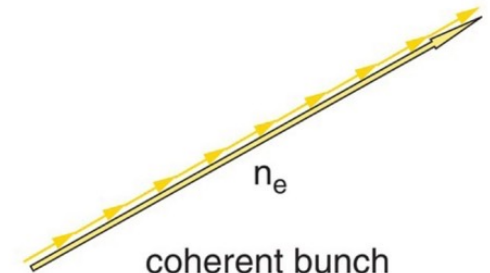

coherent bunch

The SASE process

- The more the electrons bunch and radiate in phase (that is, coherently), the stronger is the electromagnetic-field interaction with them, which in turn further enhances the microbunching phenomenon associated with coherent emission, thus increasing the degree of coherent emission ...
- This results in a longitudinal density modulation (microbunching) together with an exponential growth of the radiation power along the undulator until saturation.

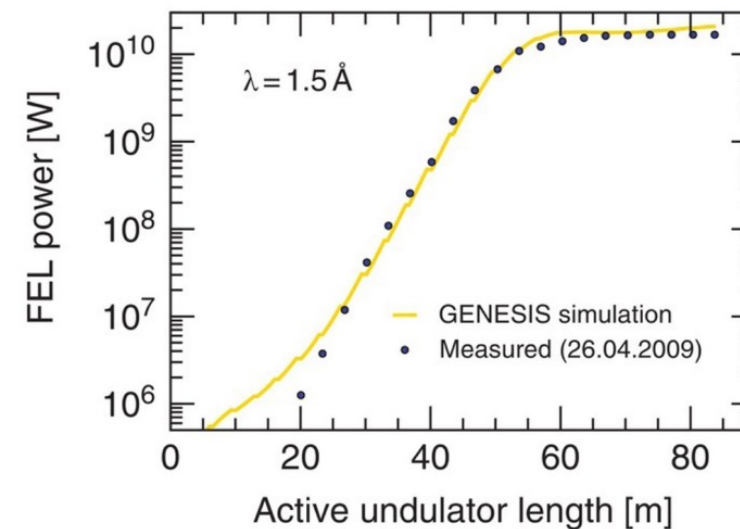
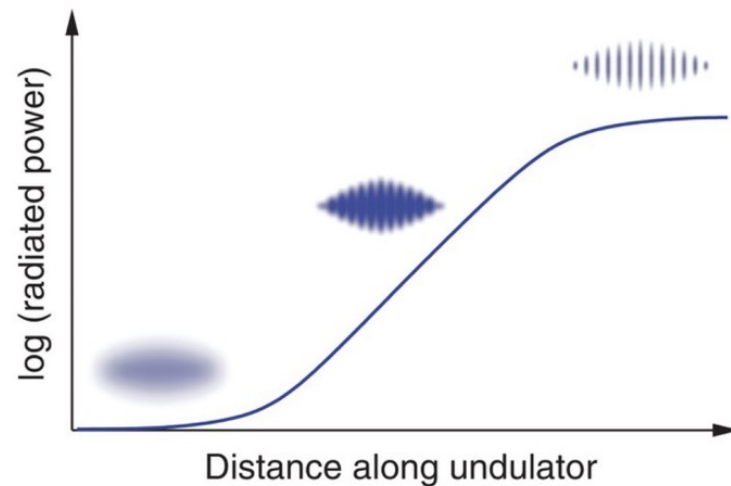

The SASE process

- The microbunches produced by the SASE process each contain approximately $n_e = 10^9$ electrons, resulting in a peak brilliance for XFELs approximately one billion times more intense than that from fourth-generation synchrotron sources.
- X-ray is fully transverse coherent, but not longitudinal

SwissFEL: Simulation for 1 Angstrom radiation

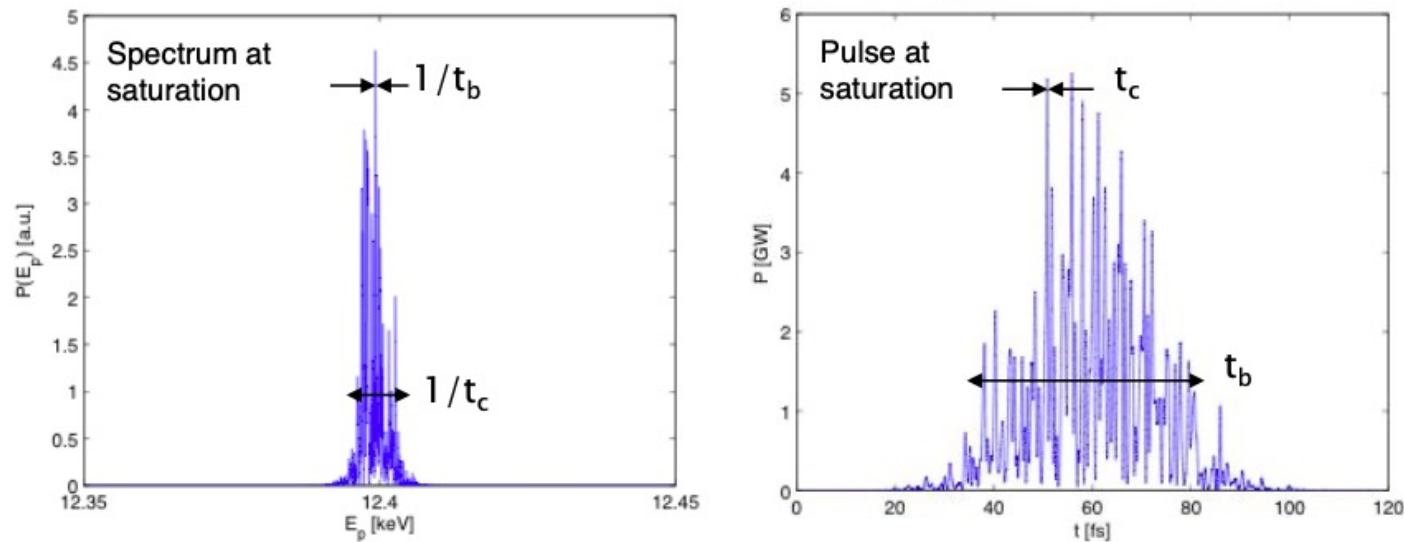



Aramis undulator

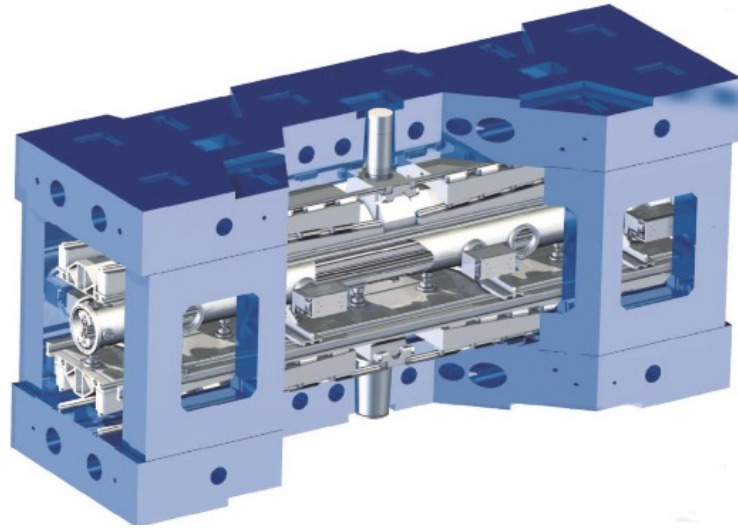

- In-vacuum, variable-gap undulators
- Undulator period 15 mm
- Nominal gap 4.5 mm for $K = 1.2$
- Array of 1060 permanent magnets (NdFeB with diffused Dy) per module
- 13 modules of 4 m length, total length 65 m



Coming next: beamlines and detectors

