

MSE 214 (Polymers)
Exercise 4 – Microstructure and Properties
15th October 2025

Question 1.

The degree of crystallinity can be determined via density measurements and calculated according to the following equation:

$$X_c = \frac{\rho_c(\rho - \rho_a)}{\rho(\rho_c - \rho_a)}$$

Where X_c is the crystallinity mass fraction, ρ is the density of the semi-crystalline polymer of interest, ρ_c is the density of the polymer if it was 100% crystalline and ρ_a is the density of the polymer if it was 100% amorphous.

Show how this equation for X_c can be obtained.

Hint: The mass of the semi-crystalline polymer of interest is the sum of the mass of the crystalline domains and the sum of the amorphous domains.

Question 2.

The polymer that you are working with has a glass transition temperature (T_g) that is too high for processing. Without using another polymer entirely, what is one strategy that you could employ to reduce the glass transition temperature? You are allowed to reprocess the polymer. You need to drop the T_g by at least 20°C .

Question 3.

When using polymers, why is it important to know their thermal processing history? Use an example to show why.

Question 4.

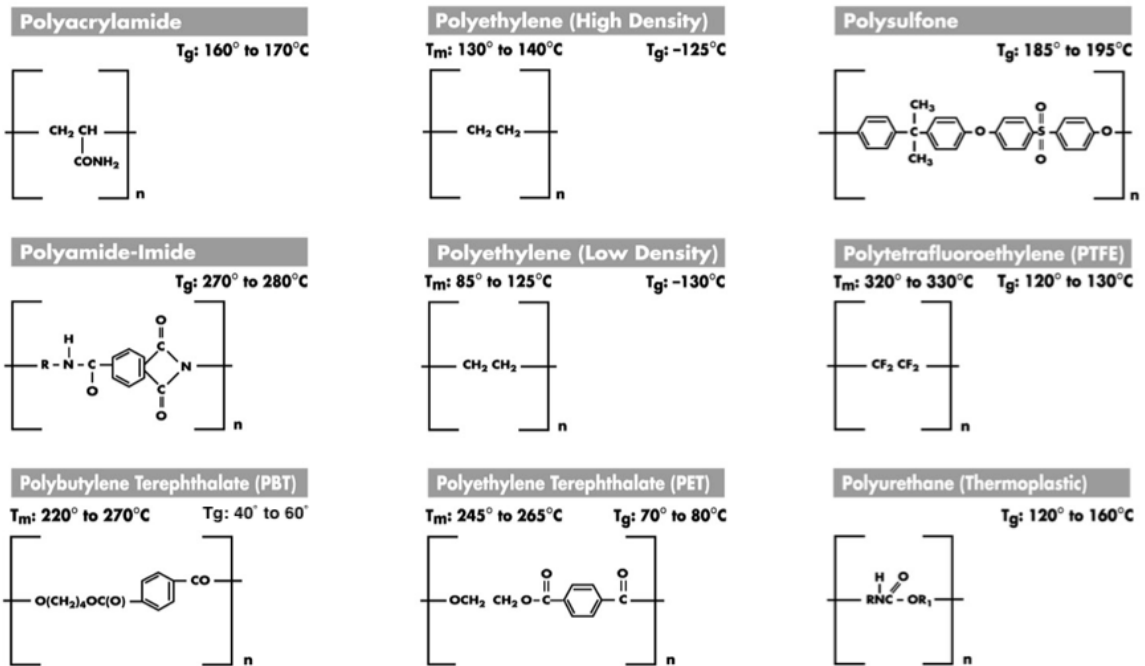

From the polymers above, pick the ones that can be used for the following applications. Outline your reasons why:

Hint: If no T_m is given, you can assume the polymer is amorphous.

- Tough material at room temperature
- Transparent shield in an oven operating at 200°C
- Flexible hose in Siberia during the winter (-25°C)
- Brittle and opaque (or translucent) material at room temperature

Question 5.

The Fox-Flory equation relates the T_g to molecular weight:

$$T_g = T_{g,\infty} - \frac{K}{M_n}$$

Where $T_{g,\infty}$ is the limiting T_g at high molecular weight, K is a constant for a given polymer, and M_n is the number average molecular weight.

Using the data below, determine the T_g (in °C) for the specified polymers at the given M_n values.

Polymer	$T_{g,\infty}$ (K)	K (K)	M_n (g/mol)
Polydimethylsiloxane	148	5900	4000
Polystyrene	373	120000	2000
Poly(methyl methacrylate)	387	210000	1000

Question 6.

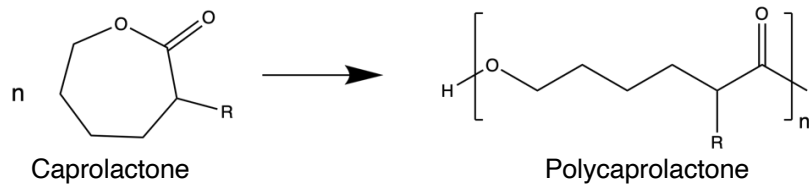

Polycaprolactones are importable biodegradable materials that are used to make a variety of FDA approved products.

- a) You desire to synthesize the most crystalline form of polycaprolactone possible. Using the schematic above as a guide, what R-group would you choose and why? Note: R here is used to represent any atom or group of atoms.
- b) You make a copolymer with monomers of caprolactone containing two different R-groups (A and B). Which of the following would display the highest crystallinity? Why?
1. A-A-A-A-A-B-B-B-B-B
 2. A-A-B-A-B-A-B-B-A-A-B

Question 7.

Differential scanning calorimetry (DSC) is often used to determine the thermal transitions that occur in a polymer during heating and cooling.

Below you will find a DSC scan of a polymer being heated to 300°C. Without going into too many details, the DSC scan essentially tells you the temperature of the thermal transition and whether that thermal transition is exothermic, endothermic, or neither.

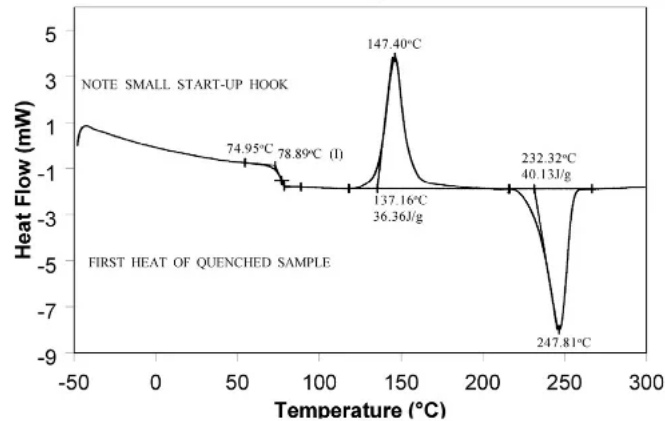

In this plot, positive changes in heat flow (Δ heat flow >0 , heat flow becomes more positive) are taken to be exothermic, and negative changes in heat flow (Δ heat flow <0 , heat becomes more negative) are taken to be endothermic.

- a) You can see two large peaks in the DSC scan, one at 147.40°C and one at 247.81°C. Your colleague, a materials scientist, tells you that one of them corresponds to (partial) crystallization of the polymer and another one corresponds to melting of the crystalline domains. Which peak corresponds to which phenomenon? Why?

Hint: Crystallization is often an energetically favorable process.

- b) If the polymer is 100% crystalline, the heat from melting would be 60 J/g. Using the DSC scan above, calculate the degree of crystallinity of the polymer at the start of the scan.

Hint 1: What is the heat of melting from this polymer? How much of that came from crystallization that happened during the DSC scan itself?

Hint 2: The degree of crystallinity can be approximated by:

$$\frac{H_{melt}^{obs}}{H_{melt}^{100\%}} \times 100\%$$

Where H_{melt}^{obs} is the observed heat of melting, and $H_{melt}^{100\%}$ is the heat of melting of a 100% crystalline polymer.