

Application du transport
electrique par des ions: les
batteries

Une application récente?

Découverte par Alessandro Volta, inspiré par le travail de Luigi Galvani



Peinture de Giuseppe Bertini: Alessandro Volta montre sa batterie à Napoleon en 1801

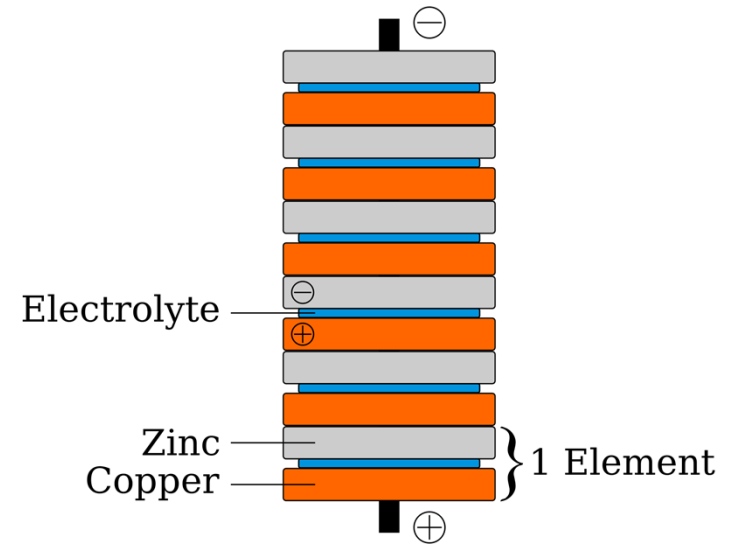

Principe de fonctionnement: Réaction d'oxydoréduction



- réduction de l'oxyde de fer : $\text{Fe}_2\text{O}_3 + 6 \text{e}^- \rightarrow 2 \text{Fe} + 3 \text{O}^{2-}$
- oxydation de l'aluminium : $2 \text{Al} + 3 \text{O}^{2-} \rightarrow \text{Al}_2\text{O}_3 + 6 \text{e}^-$

L'**aluminothermie** est une réaction d'oxydoréduction entre l'aluminium et certains **oxydes métalliques**. Il est utilisé par exemple pour souder les rails de chemin de fer.

Principe de fonctionnement: Réaction d'oxydoréduction

Quelques potentiels redox standard à 25°C

	Réducteur	Oxydant	E° (V)
Or	Au	Au ³⁺	1,50
Eau	H ₂ O	O ₂	1,23
Mercure	Hg	Hg ²⁺	0,85
Argent	Ag	Ag ⁺	0,80
Ion fer II	Fe ²⁺	Fe ³⁺	0,77
Cuivre	Cu	Cu ²⁺	0,34
Dihydrogène	H ₂	H ⁺	0
Plomb	Pb	Pb ²⁺	-0,13
Etain	Sn	Sn ²⁺	-0,14
Nickel	Ni	Ni ²⁺	-0,23
Cobalt	Co	Co ²⁺	-0,29
Cadmium	Cd	Cd ²⁺	-0,40
Fer	Fe	Fe ²⁺	-0,44
Zinc	Zn	Zn ²⁺	-0,76
Aluminium	Al	Al ³⁺	-1,67
Magnésium	Mg	Mg ²⁺	-2,37
Sodium	Na	Na ⁺	-2,71
Potassium	K	K ⁺	-2,92
Lithium	Li	Li ⁺	-3,02

Du moins réducteur

au plus oxydant



au plus réducteur

Du moins oxydant

Principe de fonctionnement: Réaction d'oxydoréduction

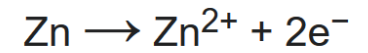
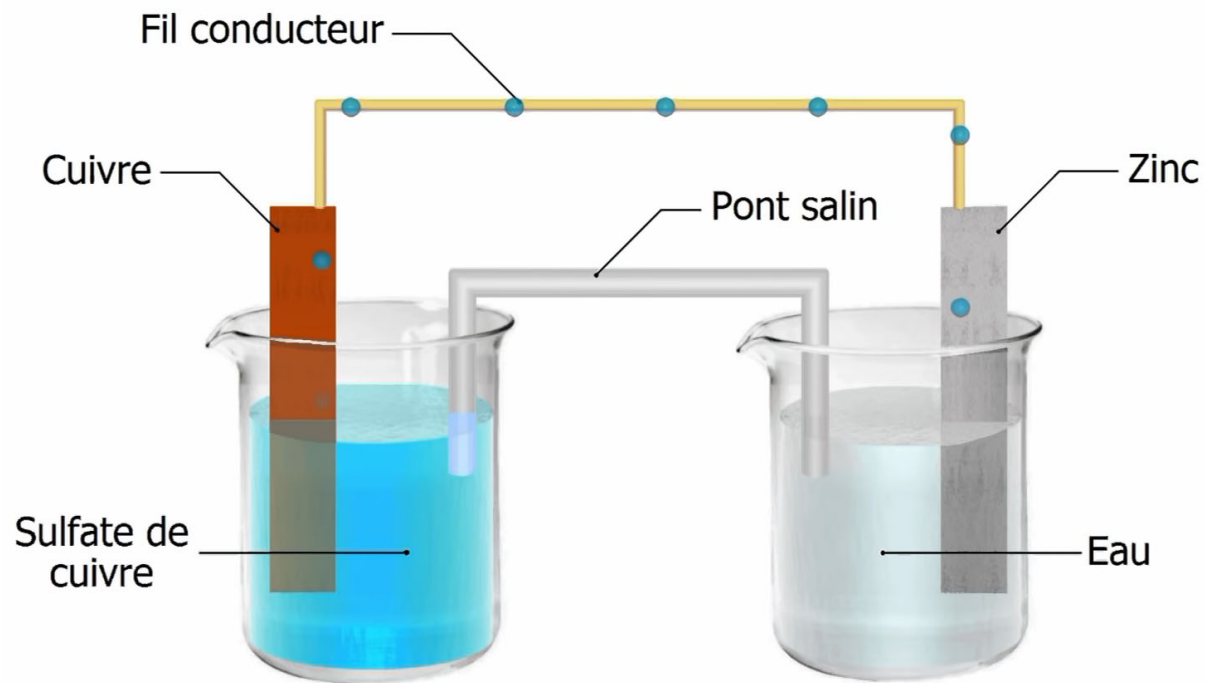

Sulfuric acid:

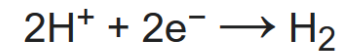

Principe de fonctionnement: Réaction d'oxydoréduction

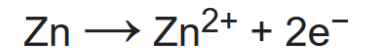
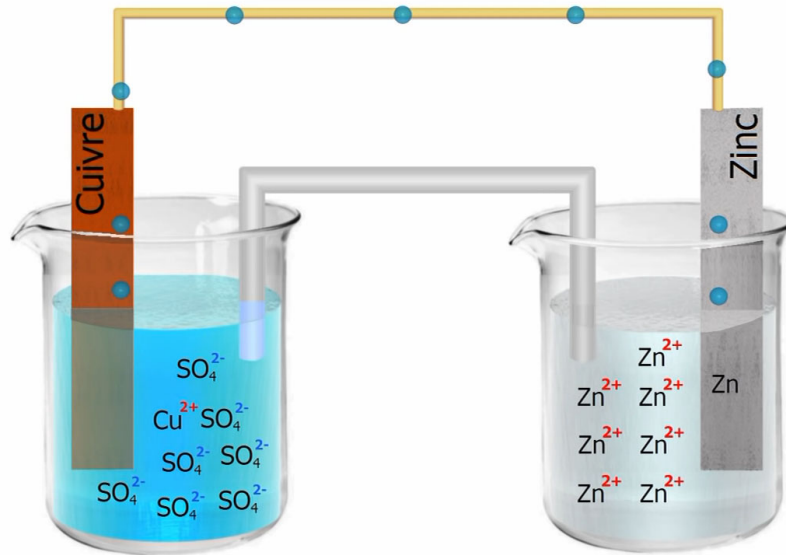

Sulfuric acid:

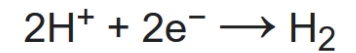

<https://www.youtube.com/watch?v=LyPxLJeHbjo>

Principe de fonctionnement: Réaction d'oxydoréduction

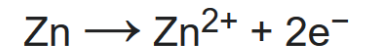
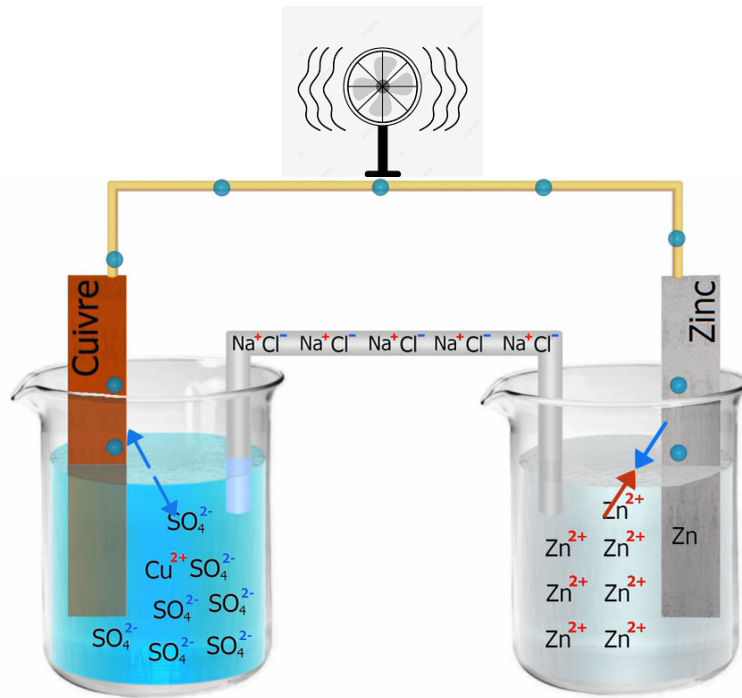

Sulfuric acid:

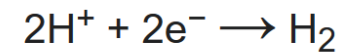

<https://www.youtube.com/watch?v=LyPxLJeHbjo>

Types de piles électriques

• Une **pile zinc-carbone** (ou pile Léclanché) est principalement utilisée pour des applications nécessitant peu d'énergie, comme une horloge murale ou une télécommande. C'est une pile non rechargeable.



Elle est constituée par une électrode en **zinc (Zn)** et le dioxyde de manganèse (**MnO₂**), avec un électrolyte constitué de chlorure de zinc et de chlorure d'ammonium

• Une **pile alcaline** est une pile compacte non rechargeable, qui fournit plus de 3 fois plus d'énergie que la pile zinc-carbone.



Le Zn est substitué par le Li.

• La **batterie lithium-ion** est actuellement la batterie la plus populaire, elle contient beaucoup d'énergie et est rechargeable. Elle se retrouve dans votre smartphone et votre ordinateur portable, entre autres.

• La **batterie au plomb** est utilisée dans le moteur à combustion de bon nombre de voitures. Cette batterie a été inventée en 1859, devenant la première batterie rechargeable.

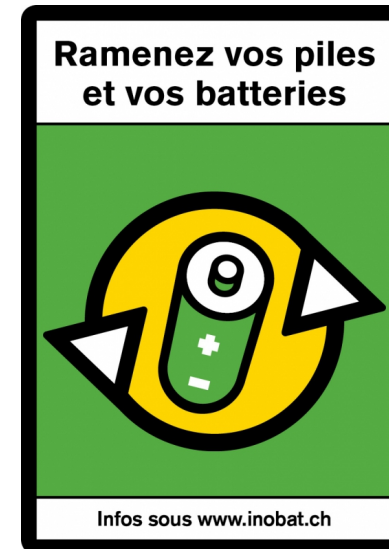

The Nobel Prize in Chemistry 2019



Ill. Niklas Elmehed. © Nobel Media.

John B. Goodenough

Prize share: 1/3



Ill. Niklas Elmehed. © Nobel Media.

M. Stanley
Whittingham

Prize share: 1/3



Ill. Niklas Elmehed. © Nobel Media.

Akira Yoshino

Prize share: 1/3

The Nobel Prize in Chemistry 2019 was awarded jointly to John B. Goodenough, M. Stanley Whittingham and Akira Yoshino "for the development of lithium-ion batteries."

DESIGNING LITHIUM-ION BATTERY CATHODES

JOHN B. GOODENOUGH

Presented by
Arumugam Manthiram
Director, Texas Materials Institute
The University of Texas at Austin

<https://www.nobelprize.org/prizes/chemistry/2019/goodenough/lecture>

EARLY WORK

1950-1980



Goodenough s'était intéressé aux oxydes et avait étudié des propriétés très variées

- Magnetic materials for first RAM memory
- Cooperative atomic orbital ordering
- Rules for sign of magnetic interactions
- Solid sodium-ion electrolyte: NASICON

<https://www.nobelprize.org/prizes/chemistry/2019/goodenough/lecture>

THE LITHIUM-ION BATTERY

HOW IT WORKS

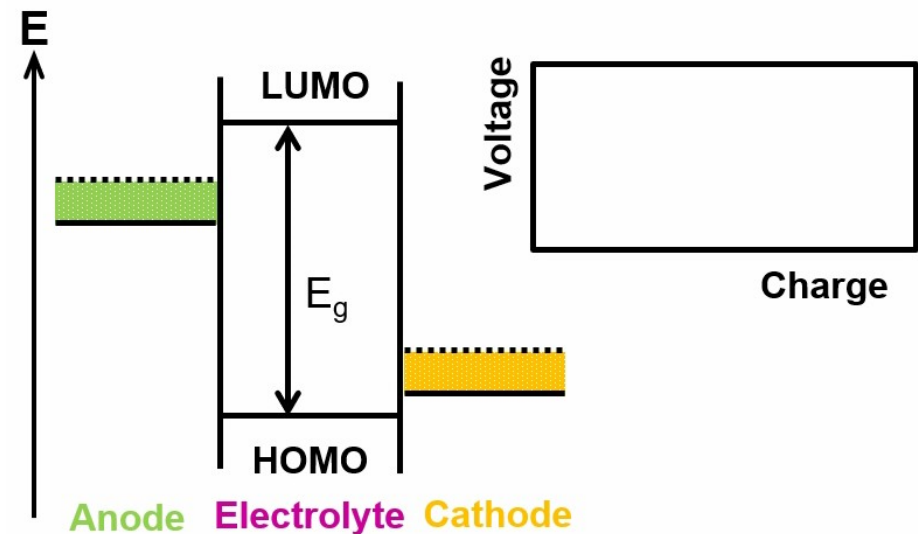
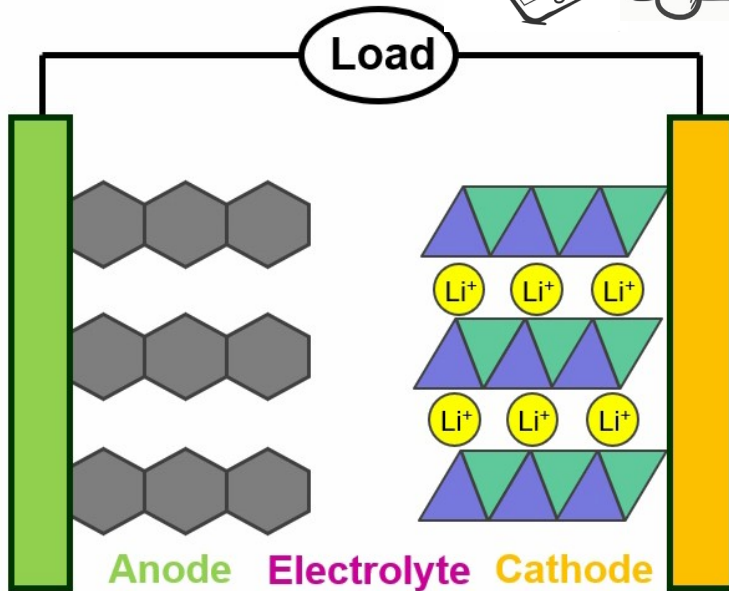
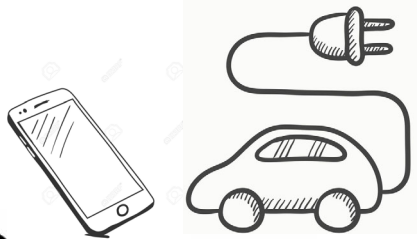

WHAT FACTORS

DETERMINE CHOICES FOR
NEW BATTERY CHEMISTRY?



1. Cost
2. Energy
3. Power
4. Cycle Life
5. Safety
6. Environment



MATERIALS

ENERGY DENSITY

User Time = (Cell Voltage) x (Amount of Lithium ions Stored)

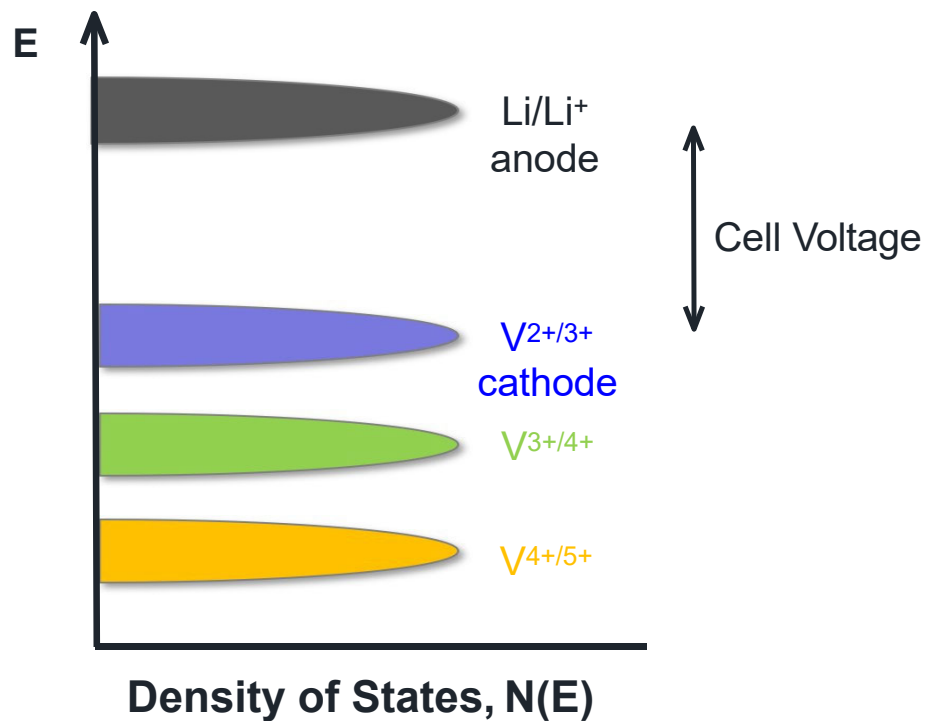

<https://www.nobelprize.org/prizes/chemistry/2019/goodenough/lecture>

INSERTING LITHIUM

HOW THE CHEMISTRY WORKS

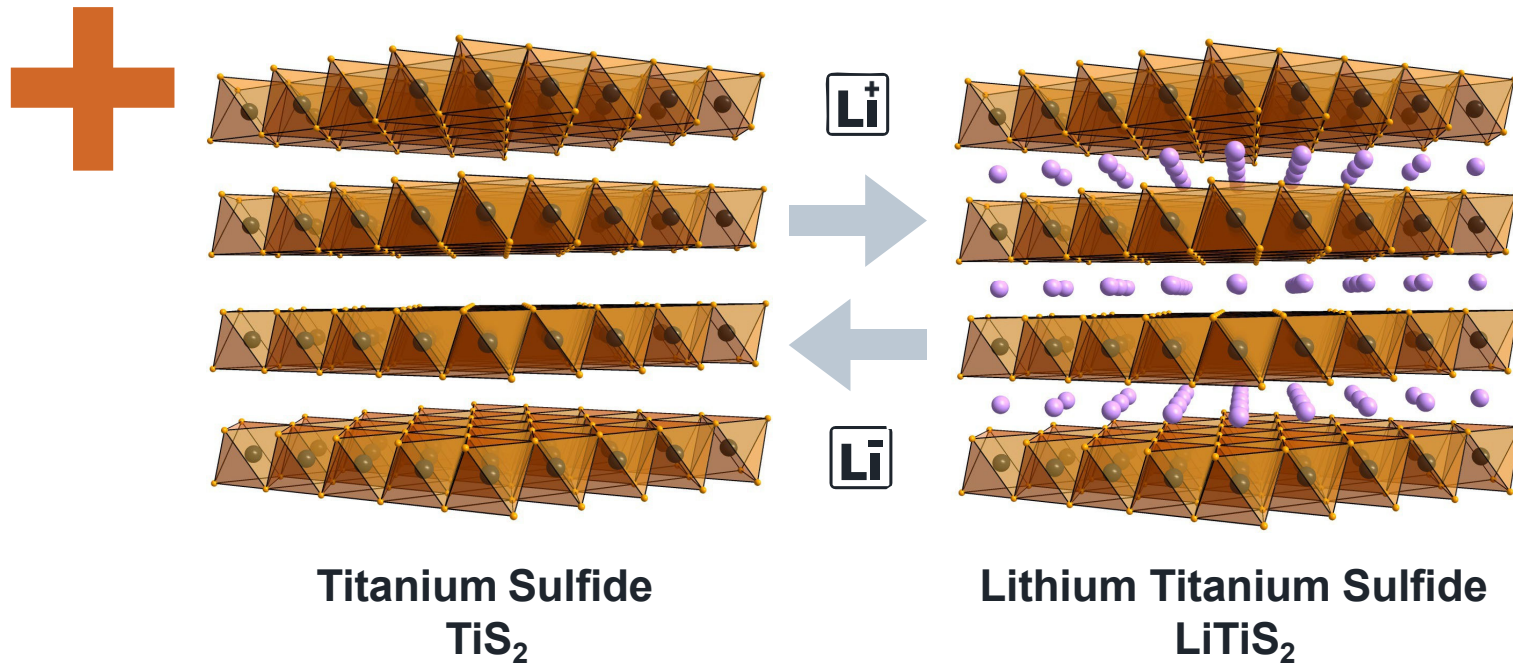

<https://www.nobelprize.org/prizes/chemistry/2019/goodenough/lecture>

ENERGY DENSITY

FROM SULFIDE TO AN OXIDE

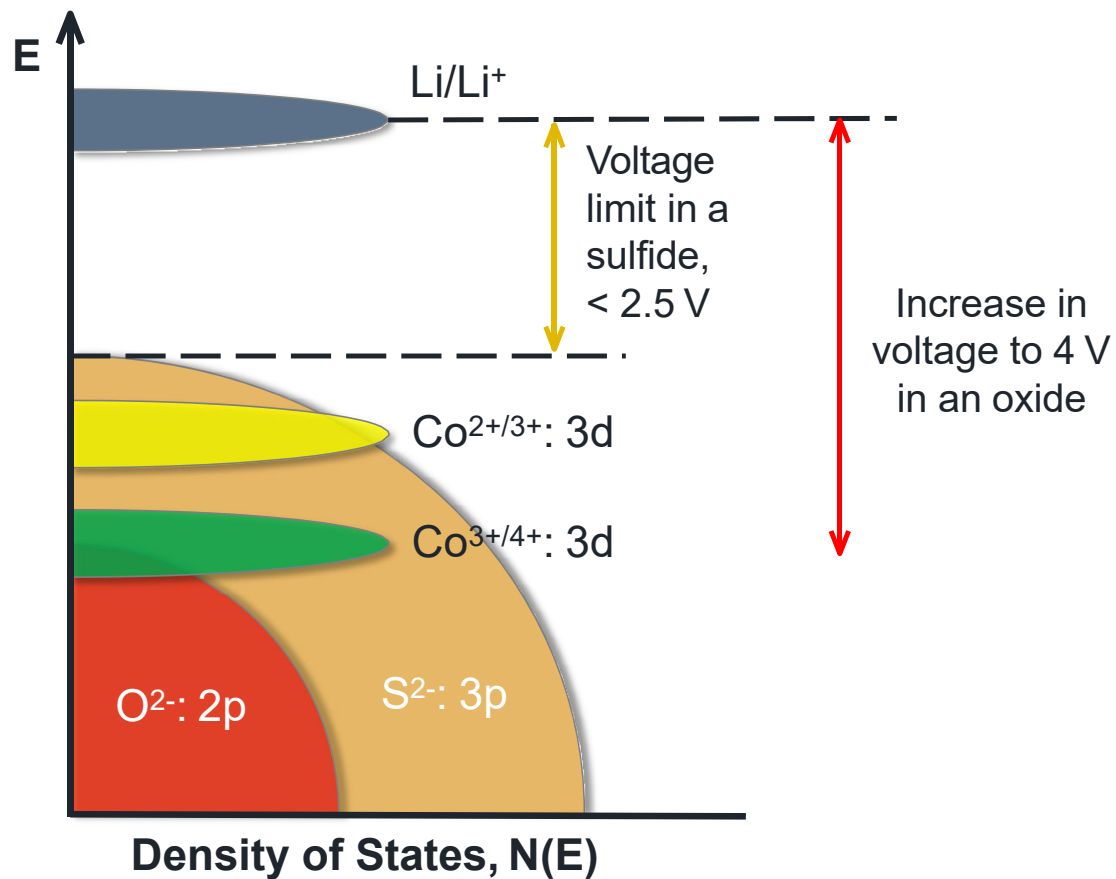

<https://www.nobelprize.org/prizes/chemistry/2019/goodenough/lecture>

MATERIALS CLASS 1

1980: LAYERED OXIDE

Citation: Mizushima, Jones, Wiseman, Goodenough — *Materials Research Bulletin* **15**, 783 (1980)

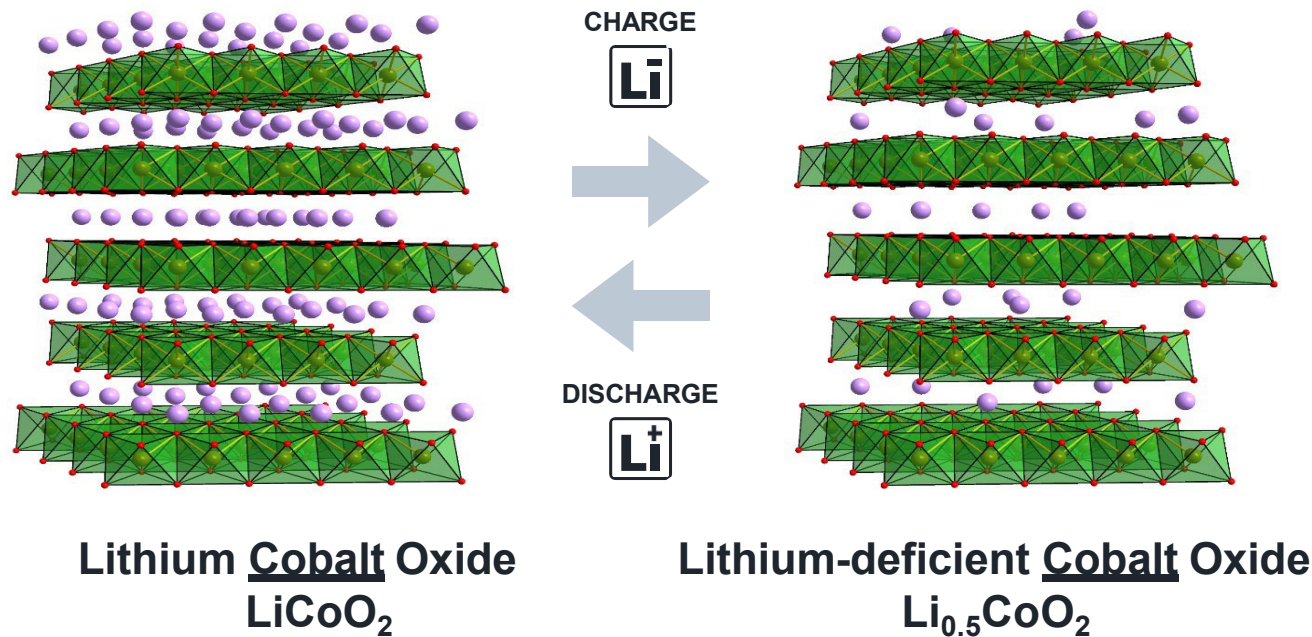

<https://www.nobelprize.org/prizes/chemistry/2019/goodenough/lecture>

MATERIALS CLASS 2

1983: SPINEL OXIDE

Citation: Thackeray, David, Bruce, Goodenough — *Materials Research Bulletin* **18**, 461 (1983)

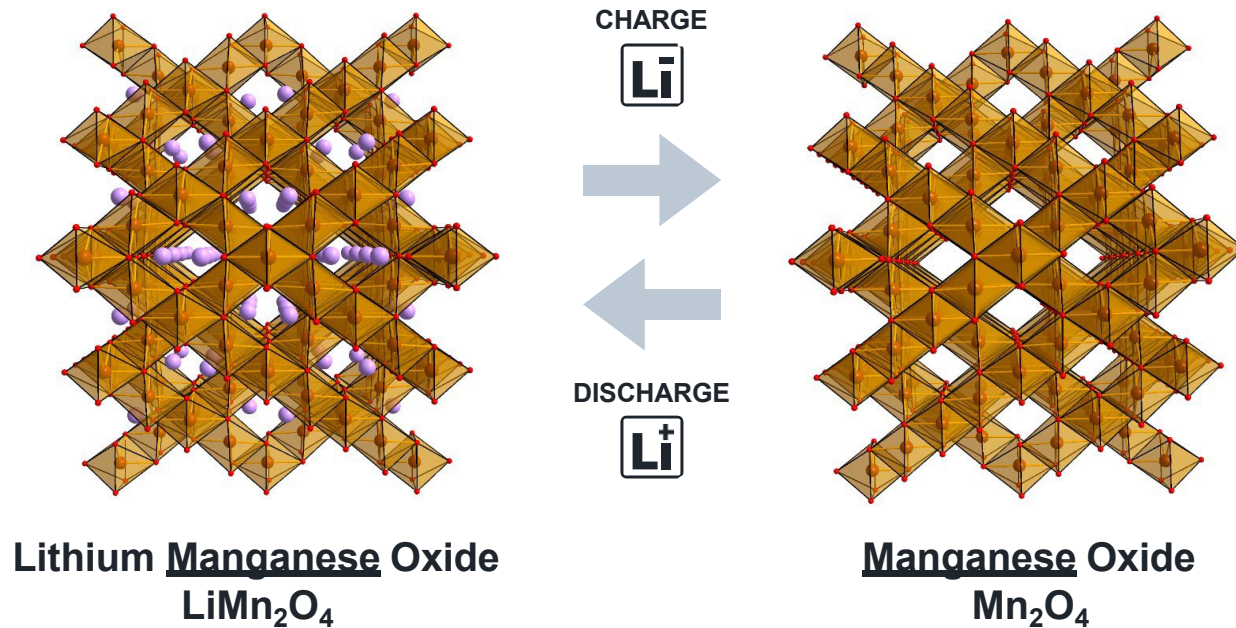

<https://www.nobelprize.org/prizes/chemistry/2019/goodenough/lecture>

MATERIALS CLASS 3

1987-89: POLYANION OXIDE

Citation: Manthiram, Goodenough — *Journal of Solid State Chemistry* **71**, 349 (1987)

Manthiram, Goodenough — *Journal of Power Sources* **26**, 403 (1989)

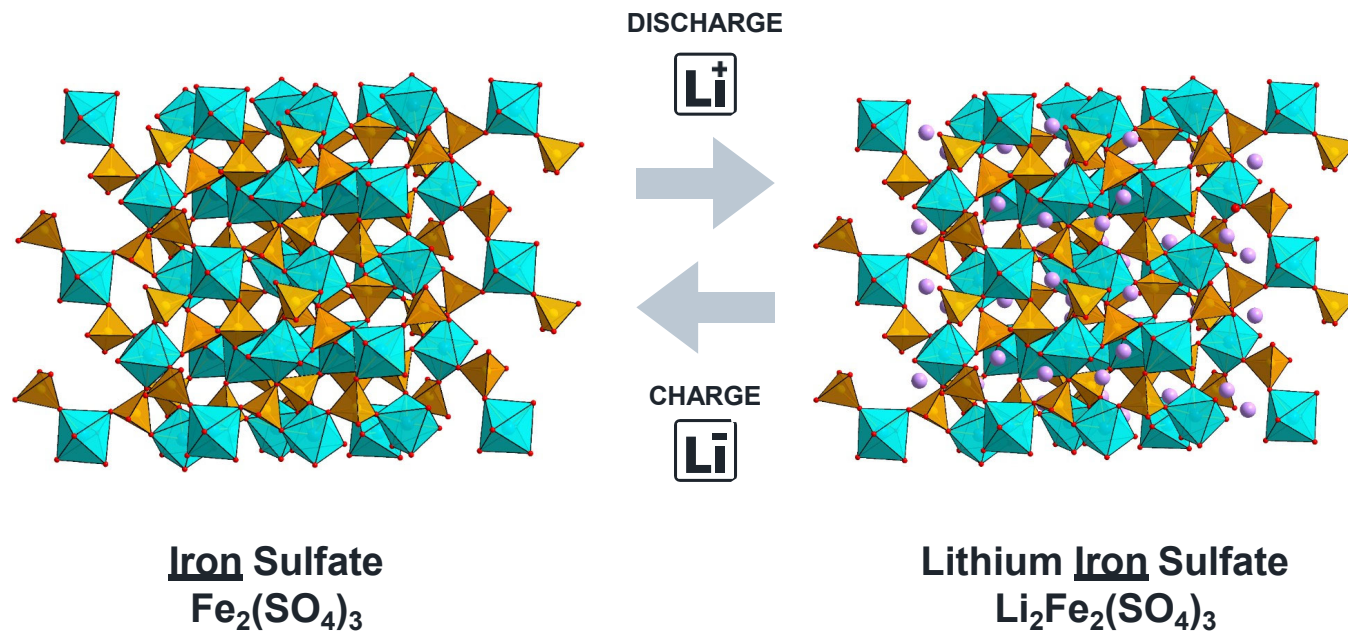

<https://www.nobelprize.org/prizes/chemistry/2019/goodenough/lecture>

MATERIALS CLASS 3

1997: POLYANION (OLIVINE) OXIDE

Citation: Padhi, Nanjundaswamy, Goodenough — *Journal of the Electrochemical Society* **144**, 1188(1997)

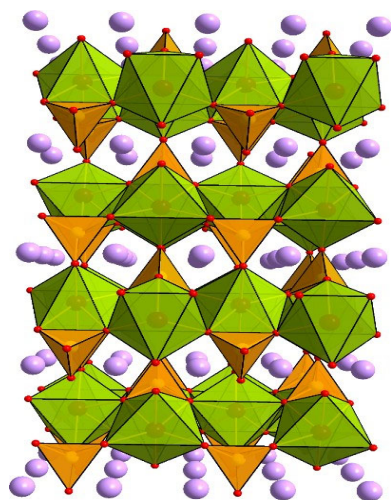

Lithium Iron Phosphate
 LiFePO_4

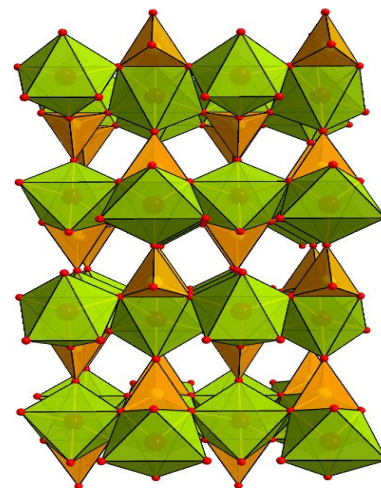
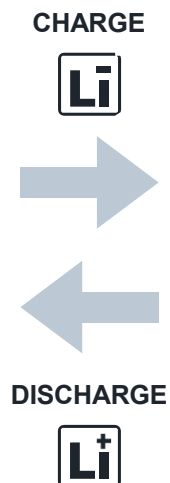

Iron Phosphate
 FePO_4

<https://www.nobelprize.org/prizes/chemistry/2019/goodenough/lecture>



KEY FINDINGS

AND HISTORICAL SIGNIFICANCE

- A fundamental study of the properties of transition- metal oxides led to the identification of oxide cathodes
- Pushed boundaries at the intersection of solid-state chemistry and physics
- The three classes of materials discovered still remain the only viable cathodes — and the basis for future development
 - Layered oxide
 - Spinel oxide
 - Polyanion oxide

<https://www.nobelprize.org/prizes/chemistry/2019/goodenough/lecture>

MOVING FORWARD



- Liberating society from fossil fuels
- Harvesting electric power from solar and wind energy
- Electricity storage as chemical energy is the key
- Affordable, safe battery technologies

<https://www.nobelprize.org/prizes/chemistry/2019/goodenough/lecture>

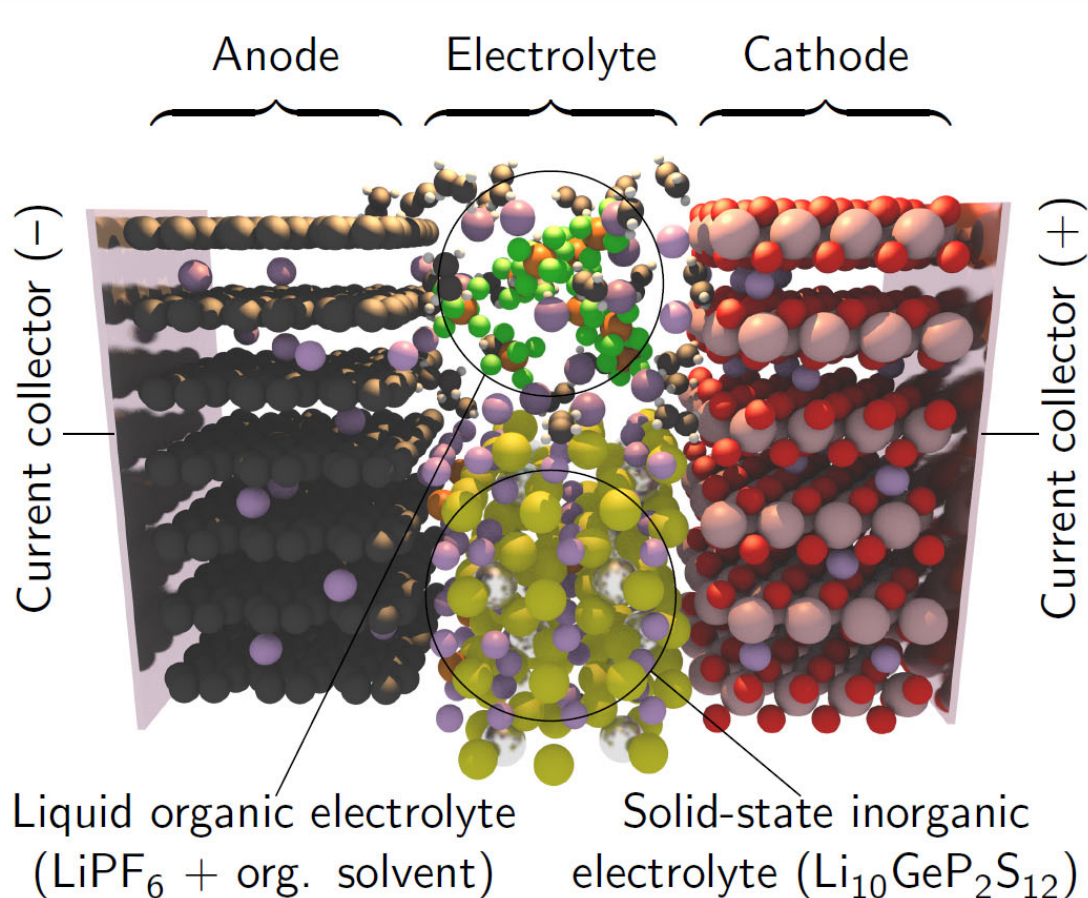

Alternatives currently under research

Anode

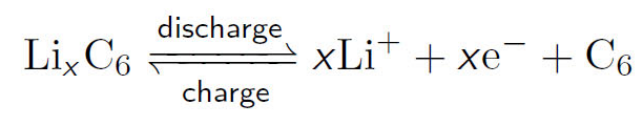

Cathode

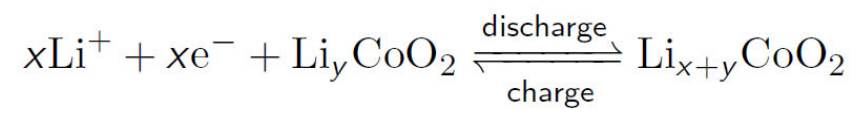

Electrolyte

- ▶ Electronic insulator
- ▶ Li-ion conductor

A lightweight, hardwearing battery that can be charged hundreds of times before its performance deteriorates. The advantage of lithium-ion batteries is that they are not based upon chemical reactions that break down the electrodes, but upon lithium ions flowing back and forth between the anode and cathode

Slide courtesy from Dr L. Kahle, THEOS

LE TEMPS

2011

MOBILITÉ

«La voiture électrique est une aberration»

Ingénieur spécialisé en moteurs nouvelle génération, Lino Guzzella enseigne à l'Ecole polytechnique fédérale de Zurich. Il explique pourquoi la voiture électrique est, selon lui, vouée à l'échec



Propos recueillis par Pierre Chambonet

Publié jeudi 28 avril 2011 à 21:44



1894, Louis Krieger (Paris, France) Lead acid battery – 60 km range

Lithium-ion car

2008 : First Tesla Roaster



2010 : Nissan Leaf



2012 : Tesla Model S



EPFL

Intercalation reactions

Lithium-ion battery

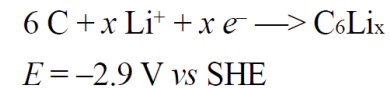
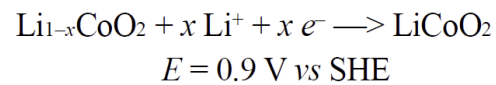
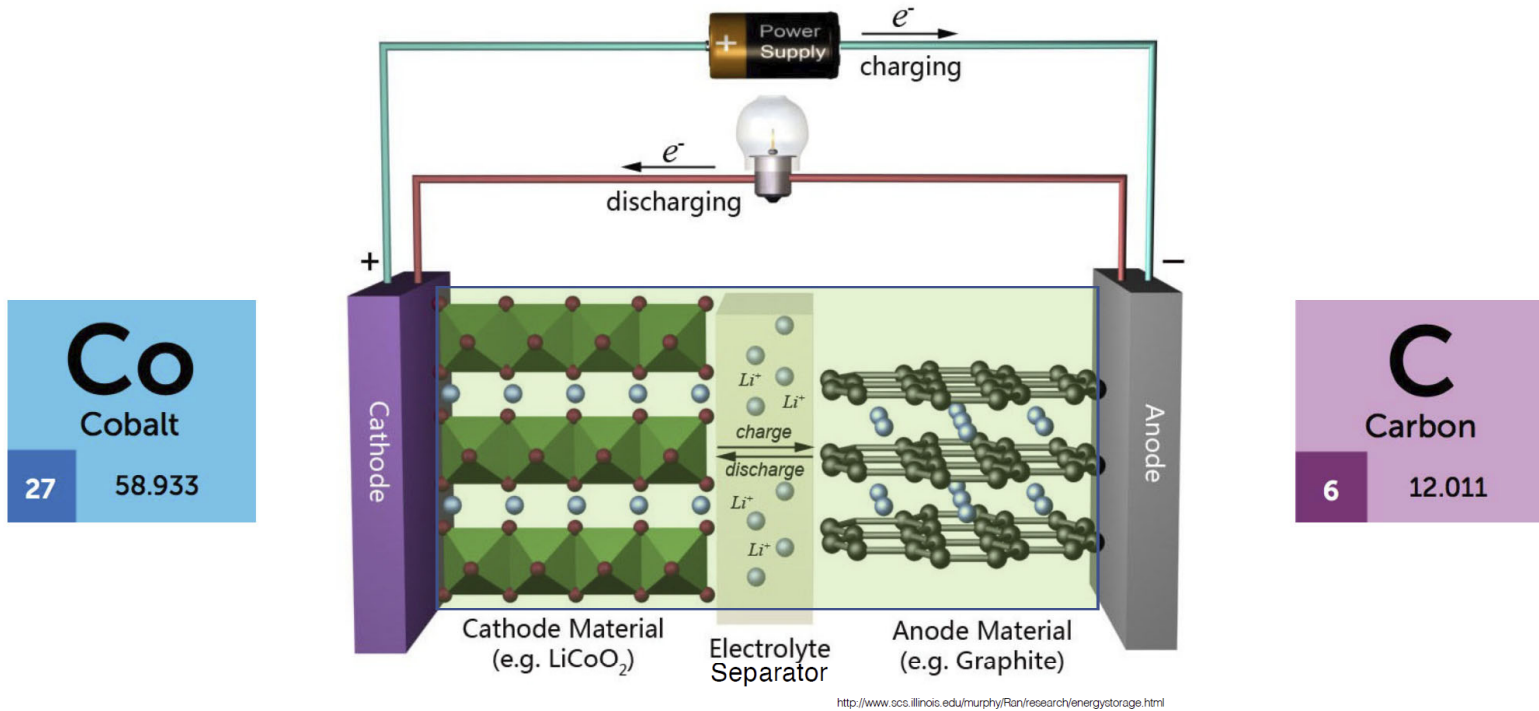

© Leçon honoraire Prof. H. Girault

1 kWh - 3 kg battery with 160 g lithium

EPFL

Packaging, Assembly and Cooling

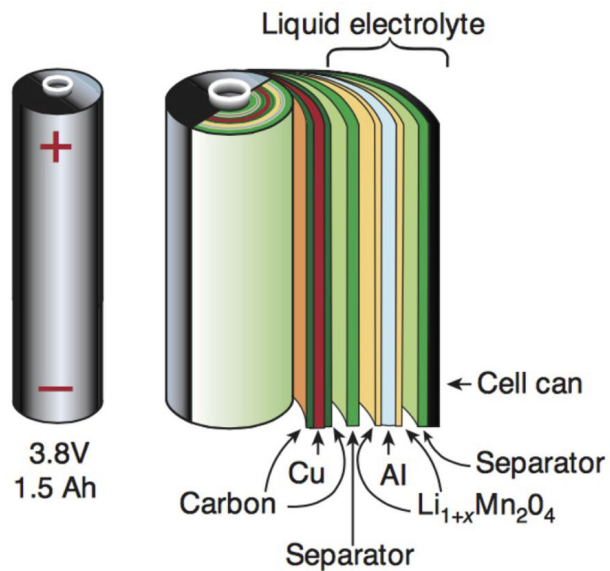

J.-M. Tarascon & M. Armand
Nature, 359 (2001) 359



7104 18650-cells in Model S 85 kWh
4416 2170-cells in Model 3 57.5 kWh

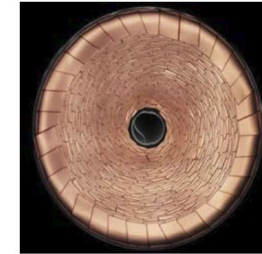

Copper contacts all along the tape
folded to decrease the resistance
and facilitate heat dissipation

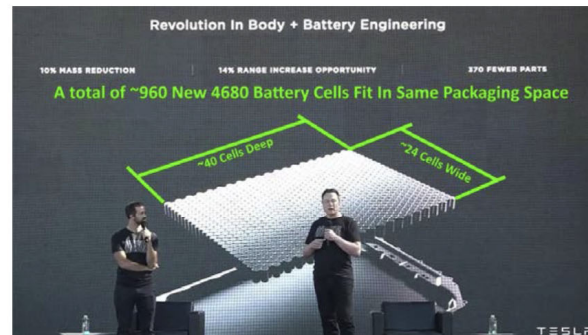

Integration of the battery in the car body parts.

BYD : Blade battery

Build Your Dreams



For the same space, the blade battery holds 50% more energy than similar battery chemistries, according to BYD.

At 96cm long and 9cm wide, BYD can pack 50% more cells into the battery pack compared to conventional LFP batteries, according to the company

Can be charged from 10% to 80% of its full capacity within 33 minutes

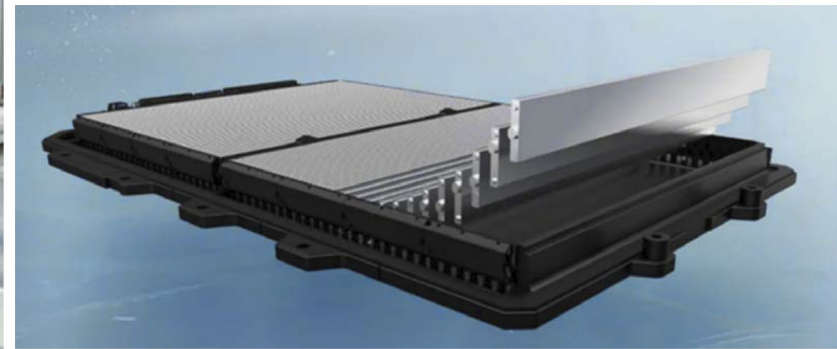

The Blade Batteries are produced in Chongqing, China, where BYD invested 10 billion yuan (€1.3 billion) to achieve an annual output of 20 GWh.

© Leçon honoraire Prof. H. Girault

EPFL

1'400 GWh lithium-ion battery cell annual production planned in Europe (70 NdD)

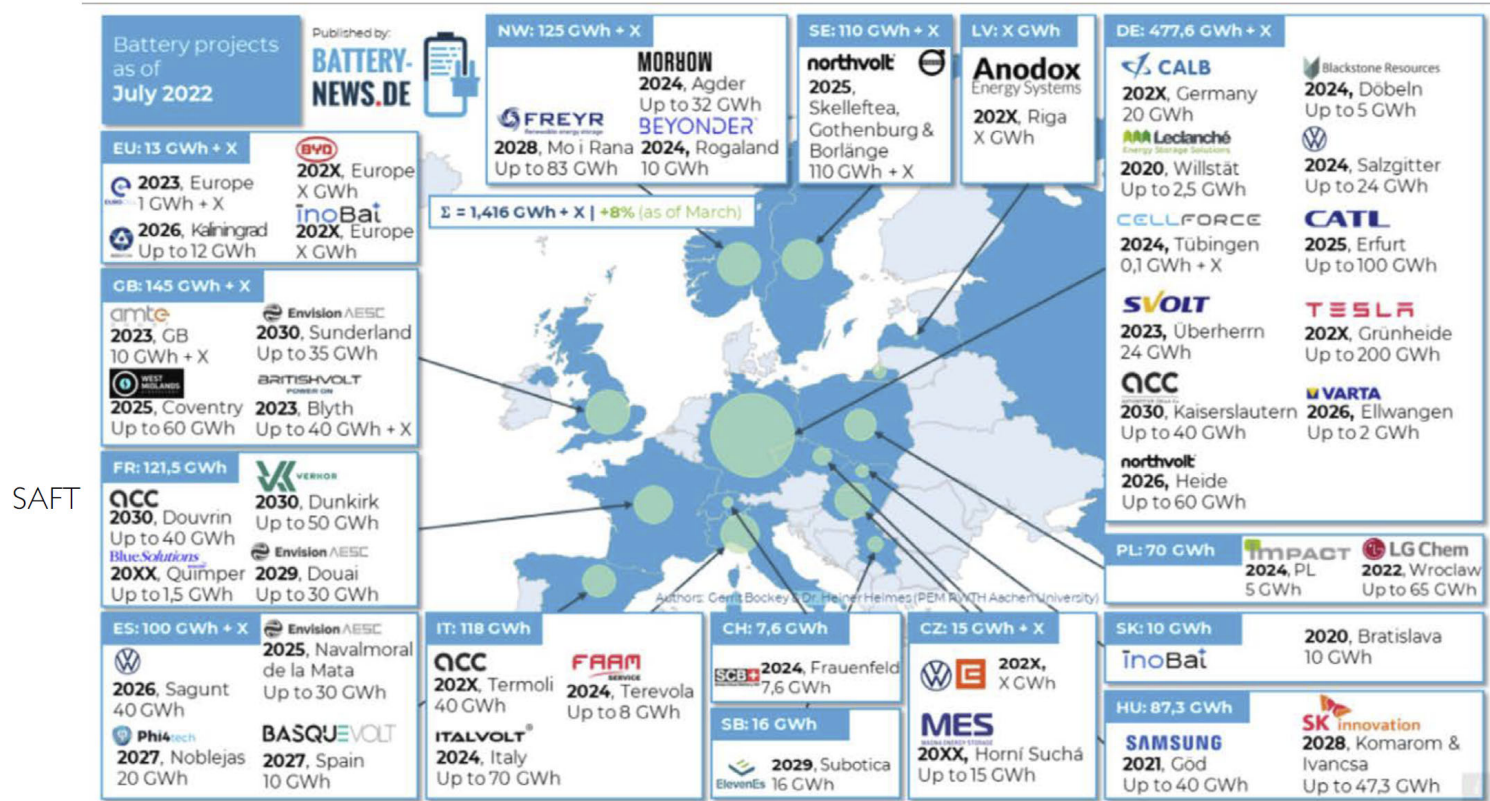

SAFT

August 18, 2022

© Leçon honoraire Prof. H. Girault

500 kWh - 750 kW - Lithium titanate Battery

EPFL Smartgrid

The medium-voltage infrastructure

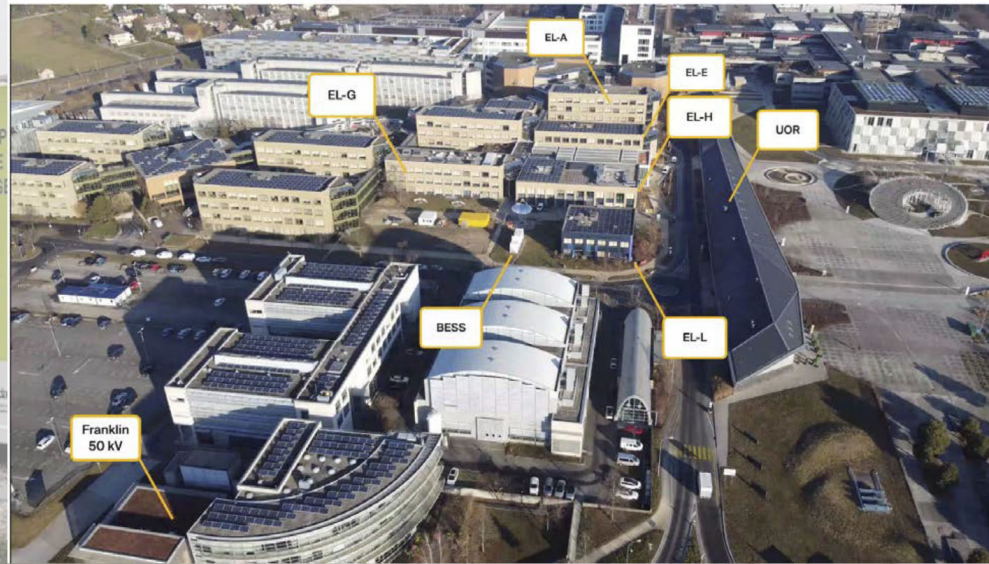

Mario Paolone – Jean-Yves LeBoudec
<https://www.youtube.com/watch?v=q-FTFrdeTig>

© Leçon honoraire Prof. H. Girault

Vanadium Redox Flow battery

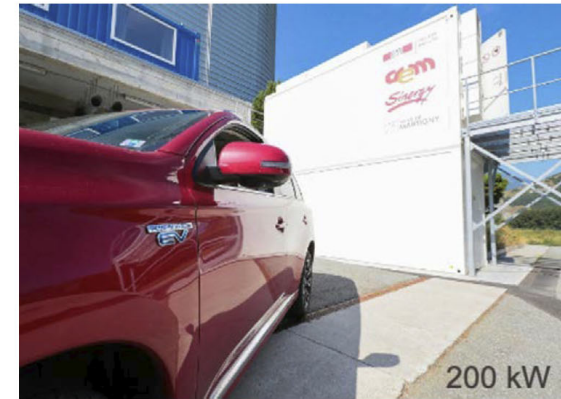
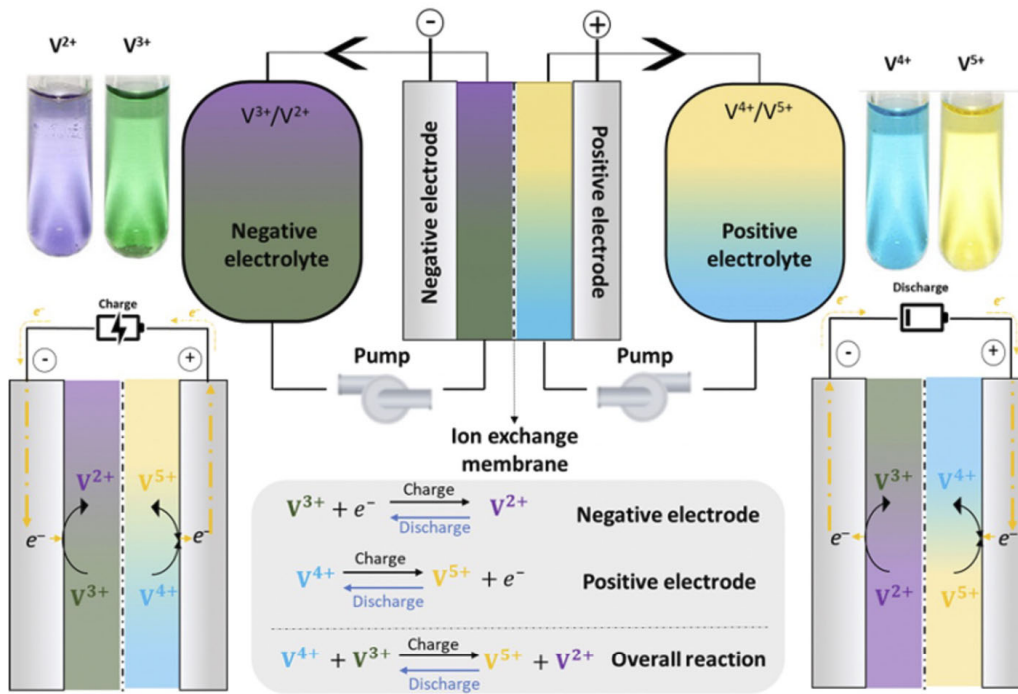

Dalian Rongke Power has connected a 100 MW/400 MWh redox flow battery storage system to the grid in Dalian, China (30-09-2022). CNY 1.9 billion (\$410 million)