

# Commande embarquée de moteurs

1 Prise en main du Microcontrôleur  
Timers - PWM

*Christian Koechli*

# Composants de l'électronique de commande

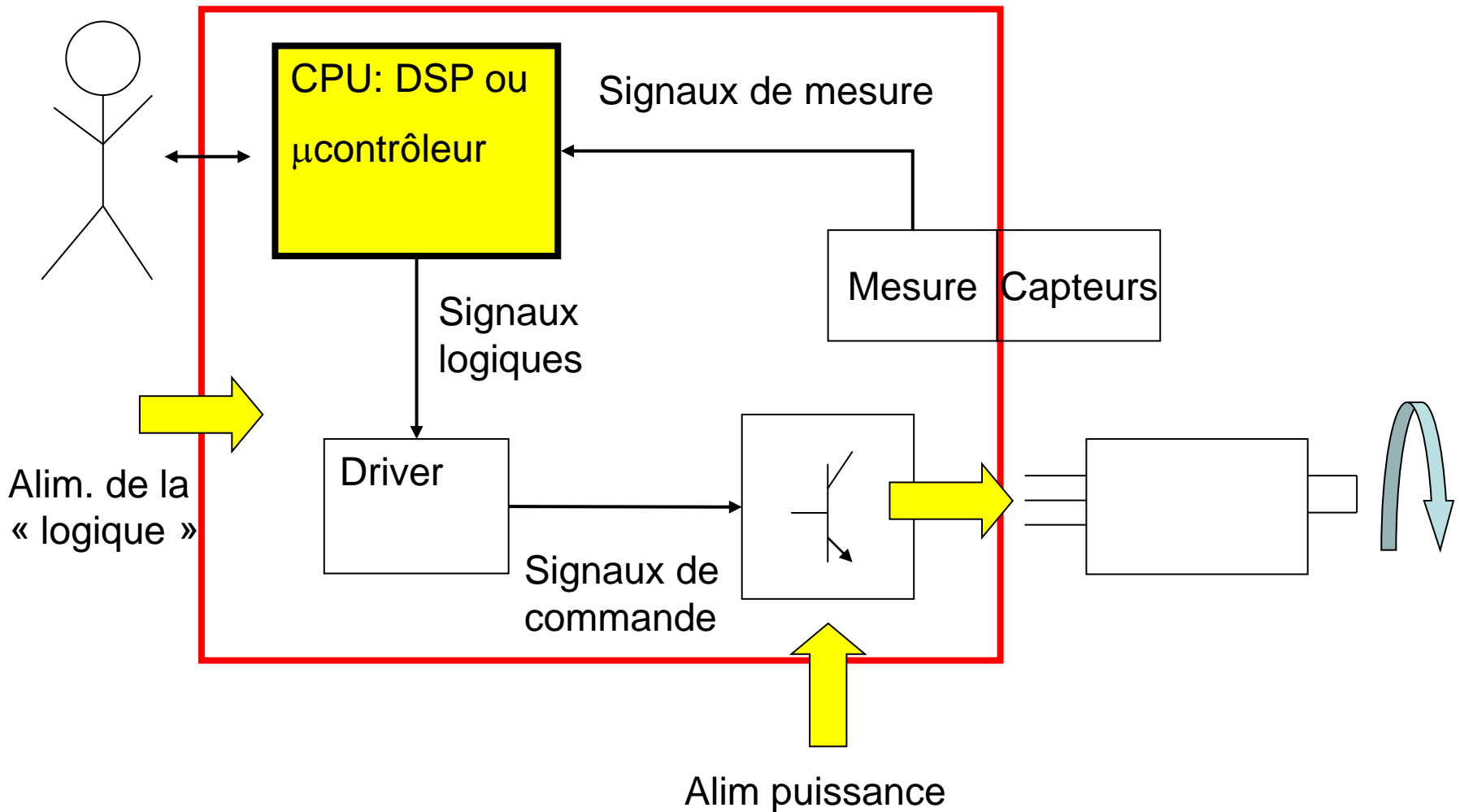

# Compteur

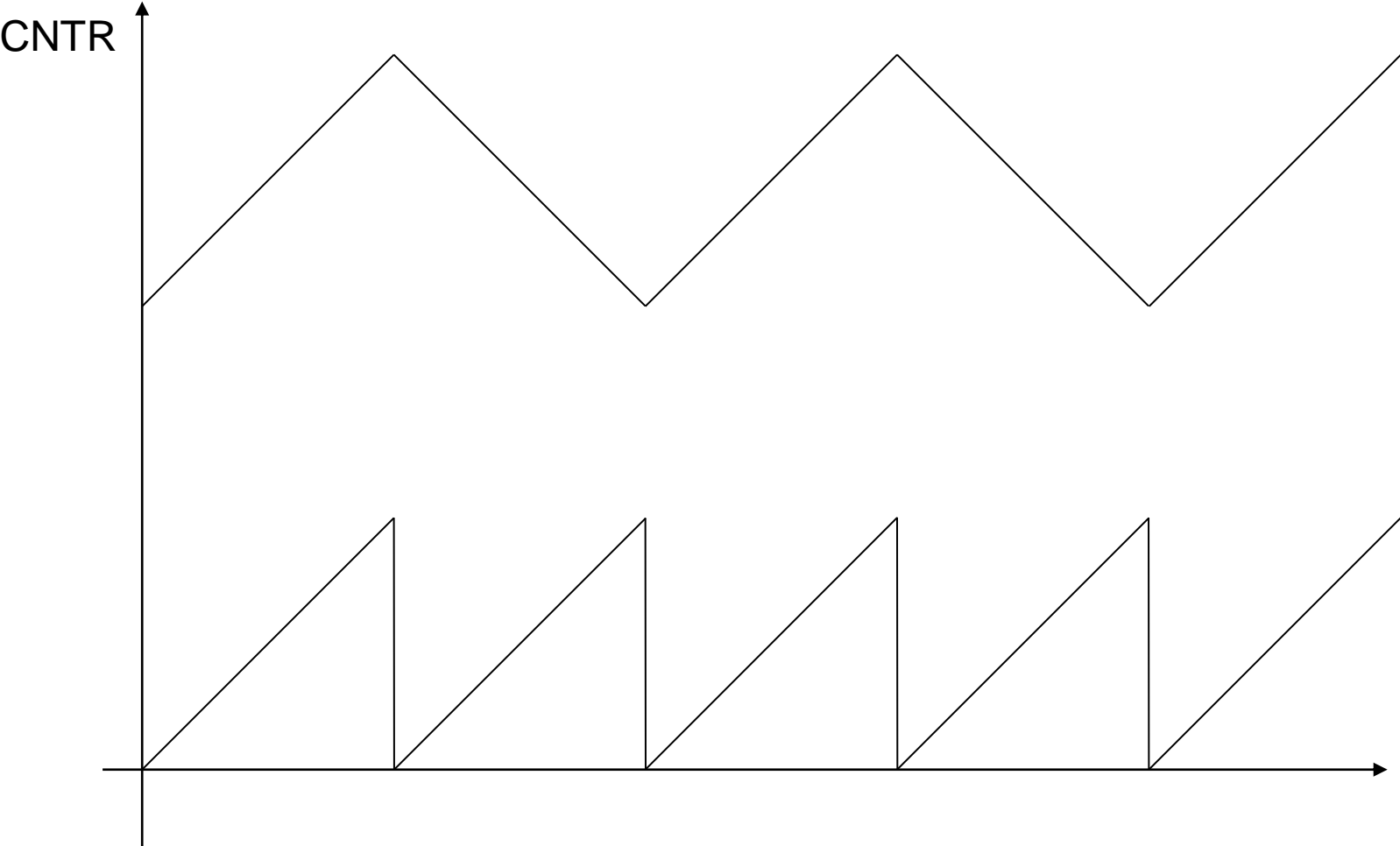

# Compare - PWM (MLI)

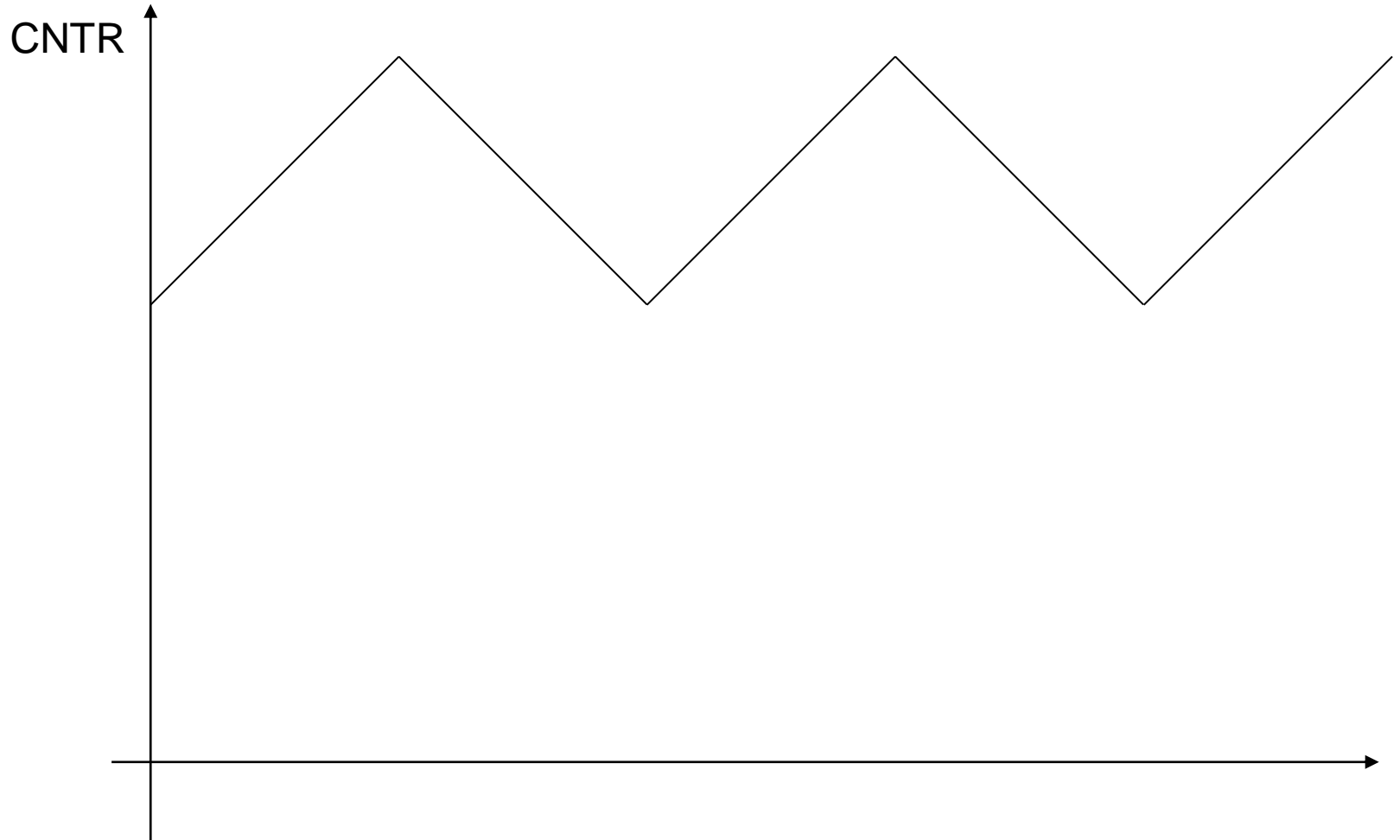

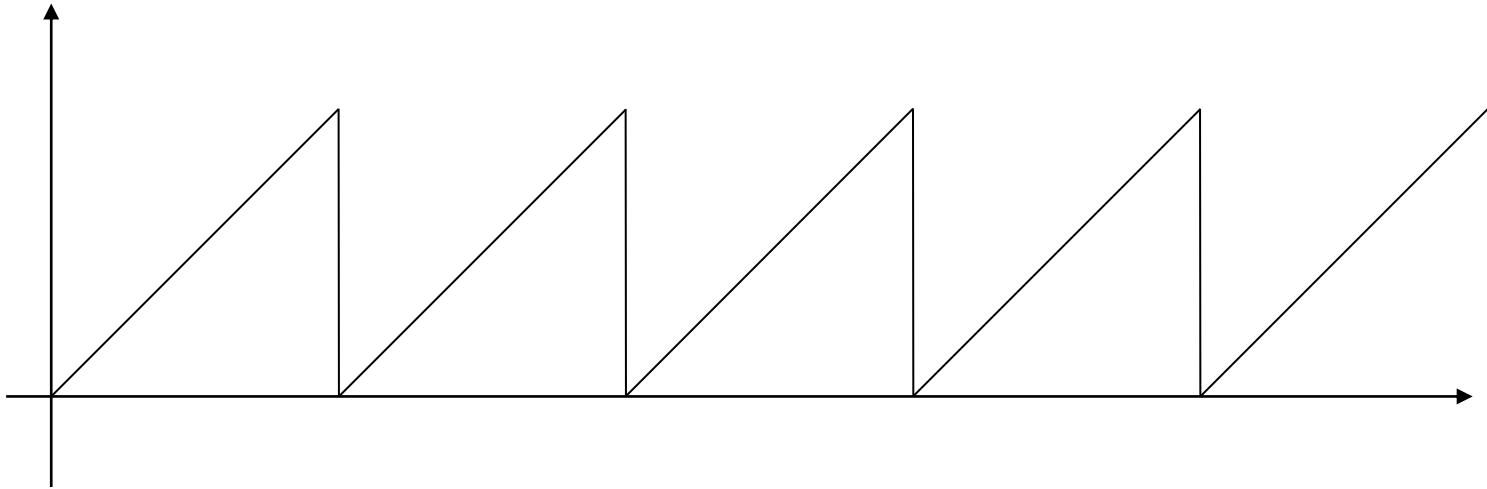

# Input capture



# Timers

- 1 advanced control timer 16-bit (TIM1)
- 4 General purpose timers (TIM2-TIM5)
  - 2x 32-bit (TIM2 & TIM5)
  - 2x 16-bit (TIM3 & TIM4)
  - Utilisation DMA,  
interface capteur incrémental (QEP)
- 3 General purpose timers 16-bits (TIM9-TIM11)

# TIM9

Notes:	
	Preload registers transferred to active registers on U event according to control bit
	event
	interrupt

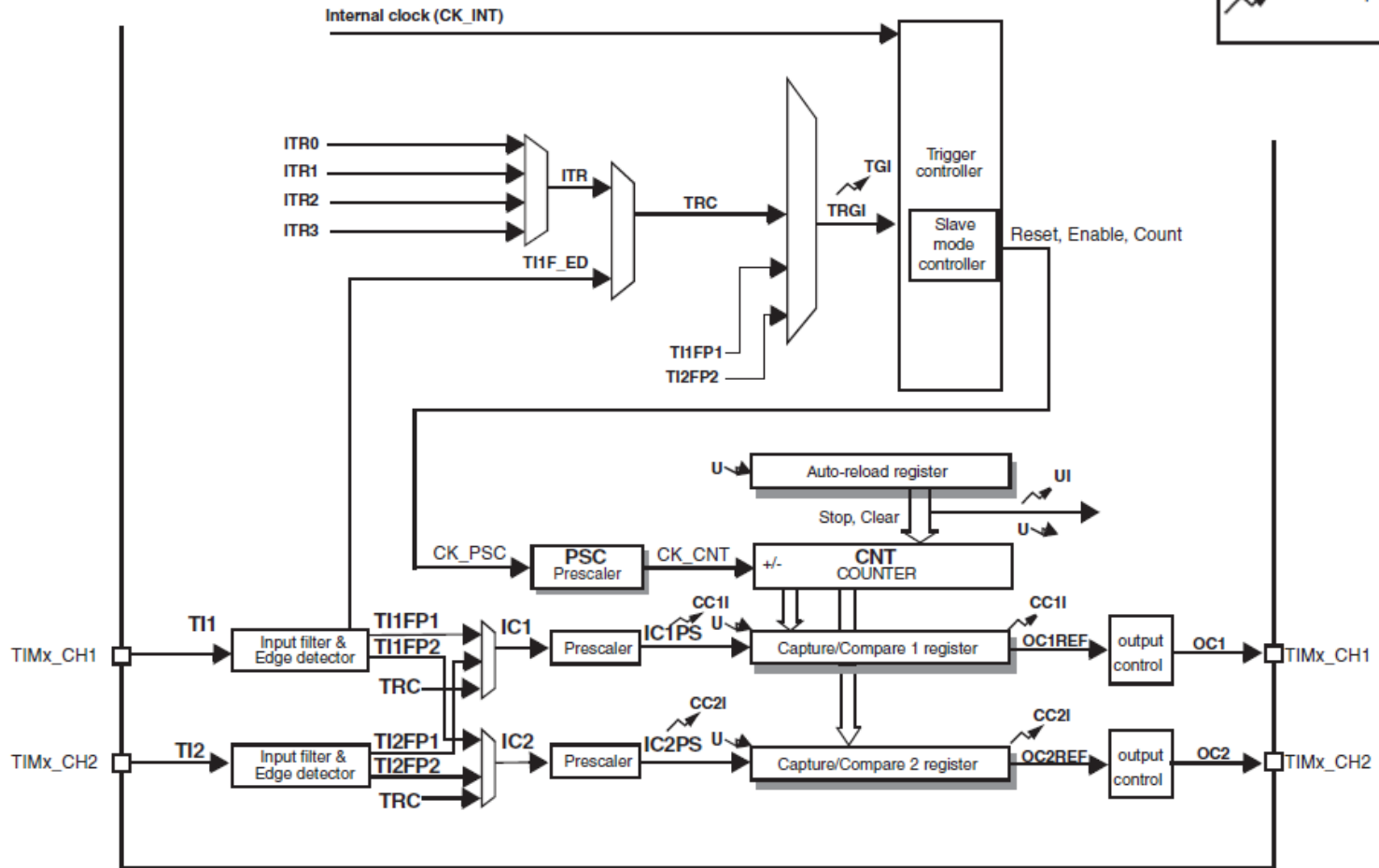

# TIM1

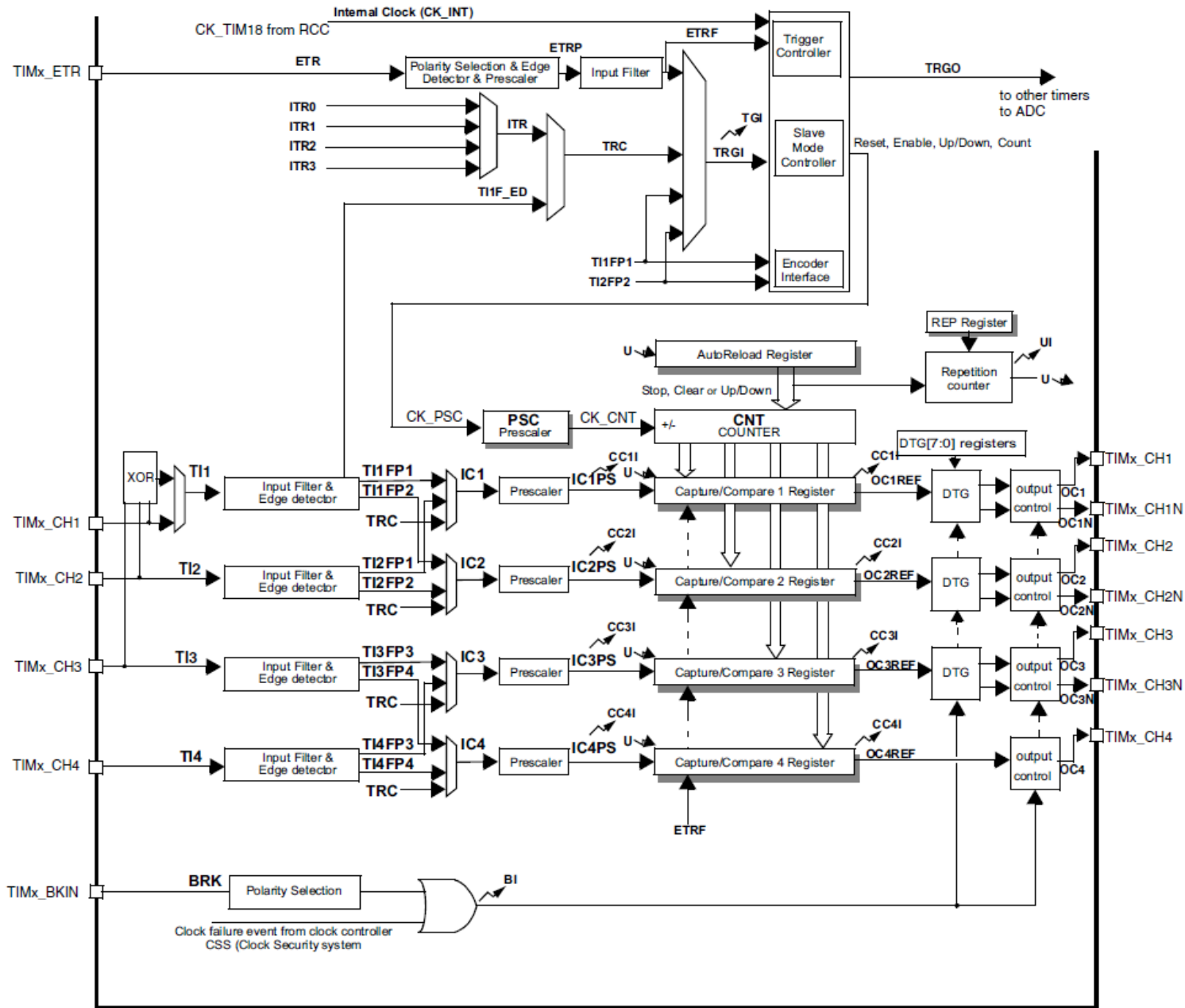

# Mode et exemple d'événements

Figure 59. Update rate examples depending on mode and TIMx\_RCR register settings

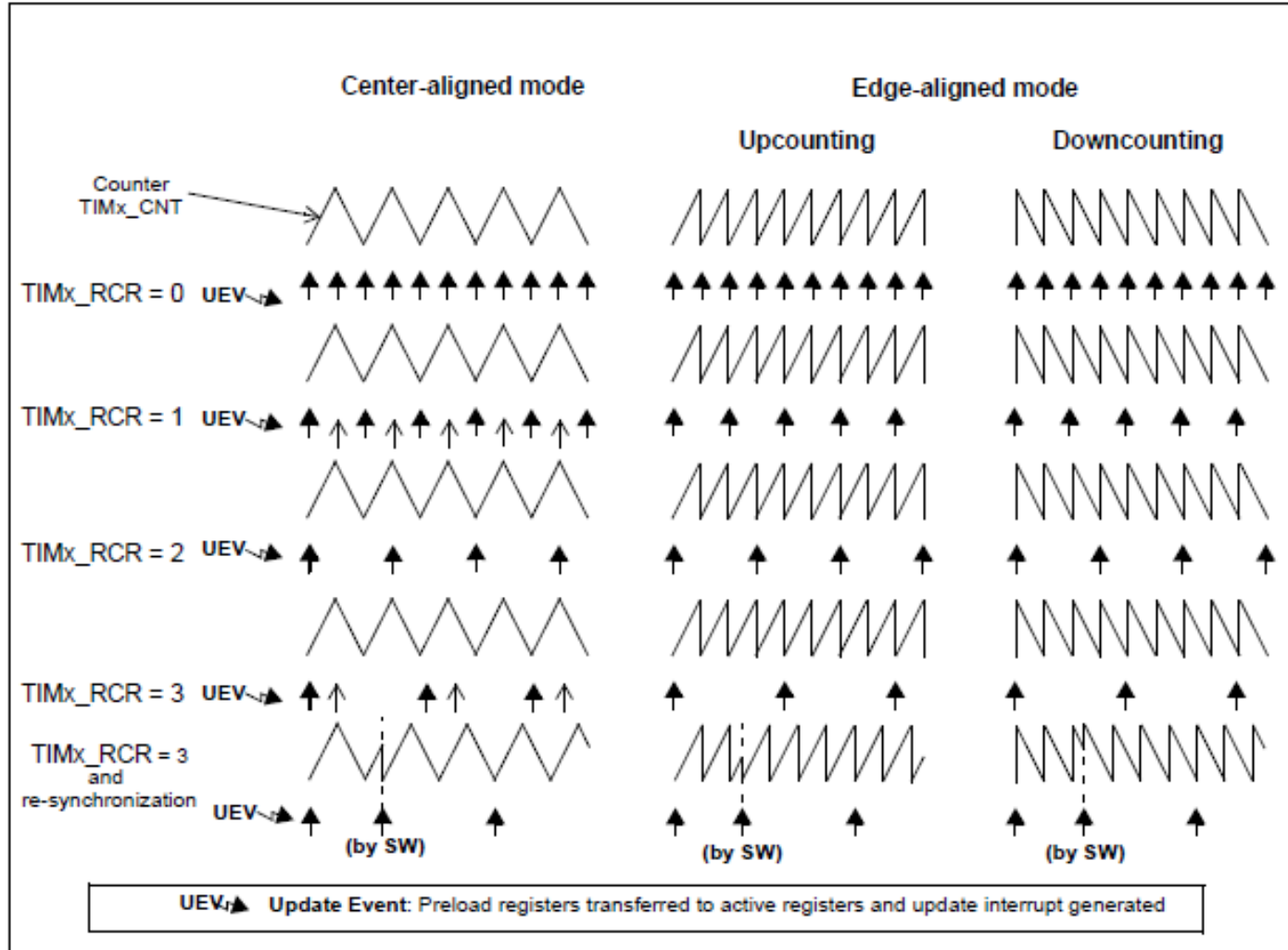

# Configuration 1

- Slave mode, trigger source, clock source
- Channels:
  - Capture
  - Output compare
  - PWM
  - Forced Output
- Break Input
- One pulse

# Configuration 2

- Prescaler
- Mode: UP / Down / Center align mode(1-3)  
(interrupt flag set when counting 1=down, 2=up, 3=UP and down)
- Period
- Trigger Output (TRGO)
- Break state/polarity
- Dead Time

# Dead time

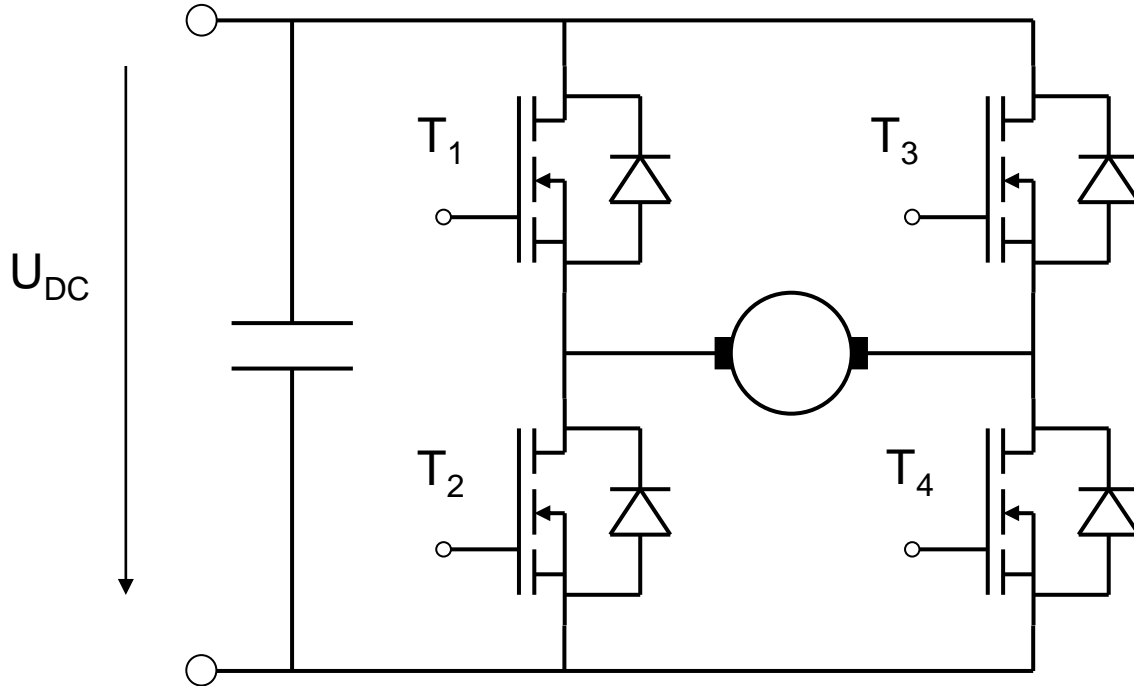

# PWM Channel configuration

- PWM Mode 1 = Active Low
- PWM Mode 2 = Active High
- Pulse = Niveau de comparaison
- Polarity = signal de sortie lorsqu'actif

# Watchdog timers

- Assurent que le uc n'est pas planté
- Compteurs à ne jamais laisser atteindre 0
- 2 possibilités:
  - Independent watchdog (IWDG)
  - Window Watchdog (WWDG)