

# Commande embarquée de moteurs

## 1 Prise en main du Microcontrôleur Microcontrôleur

*Christian Koechli*

# Composants de l'électronique de commande

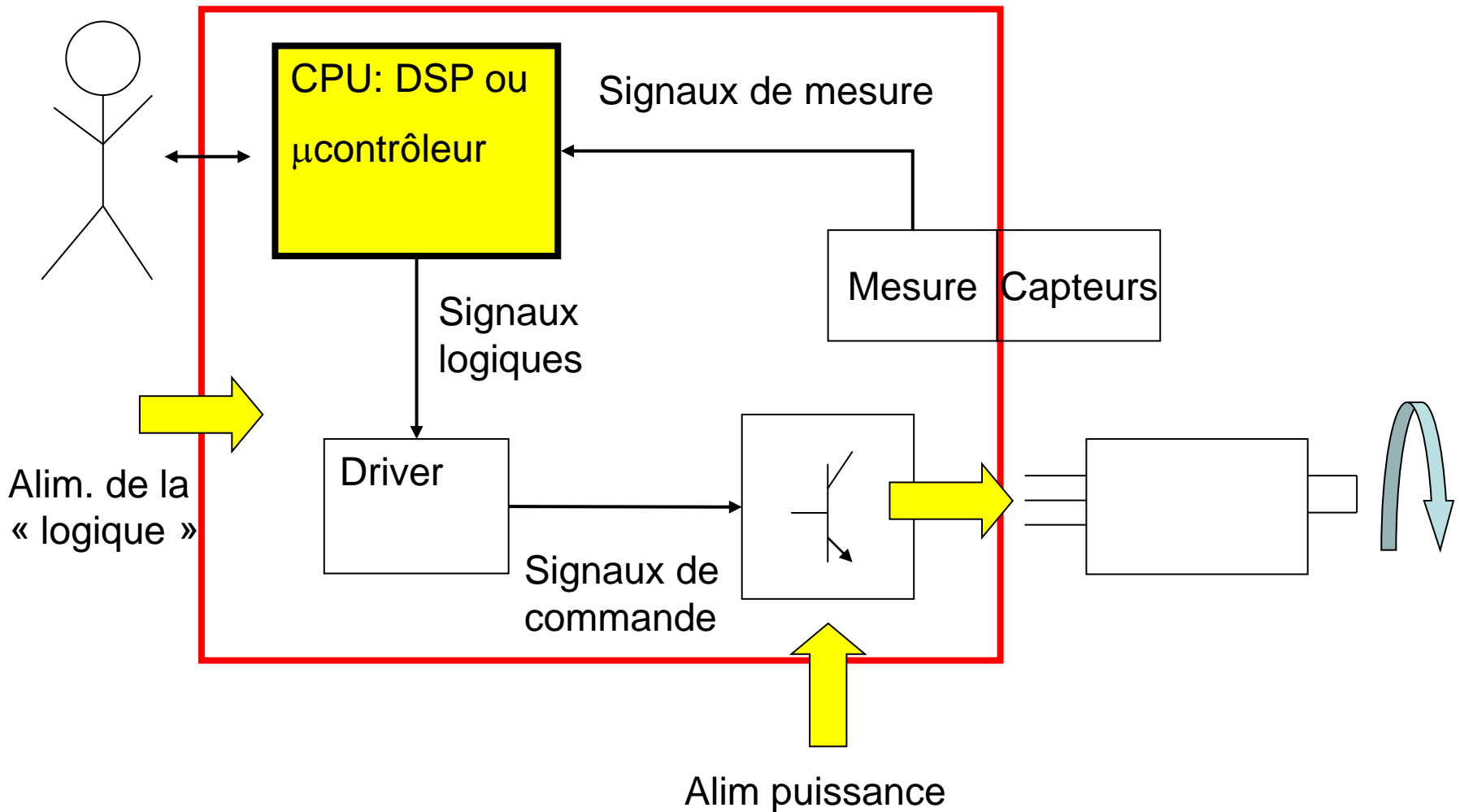

# Tâches du CPU

- Calculer les paramètres de commutation et de réglage
- Effectuer la commande des transistors (Pwm)
- Mesurer les grandeurs de réglage (AD, IO)
- Communiquer avec l'utilisateur (CAN, RS232, SPI, I2C, AD, IO)
- Surveiller que rien ne casse

# μC: STM32F401RE

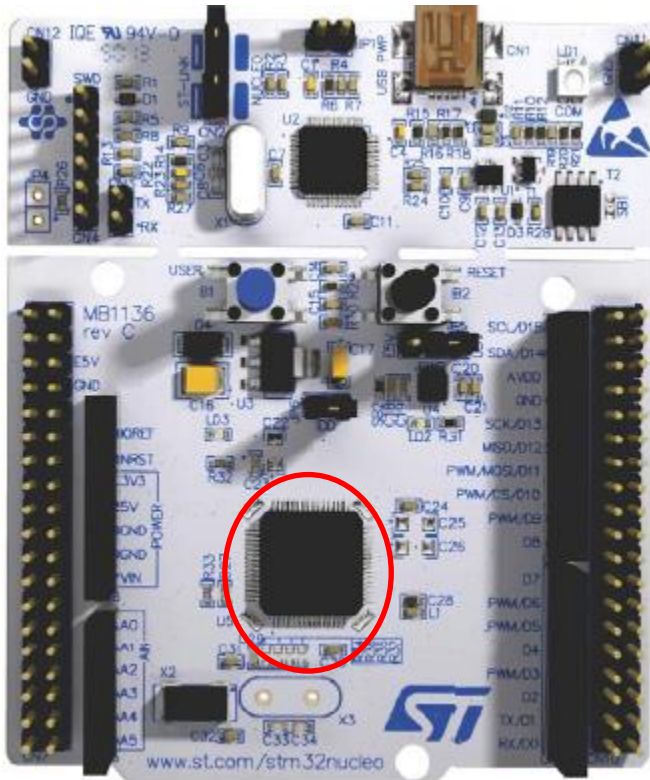

- ARM Cortex M4 (32bit) avec FPU + DSP
- 512KB flash /96KB RAM
- 84Mhz
- 64 pattes
- Basse consommation
- 4.5\$ (1000 pièces)



# Famille STM32









## STM32 32-bit Arm® Cortex®-M MCUs

Category	MCU Model	CoreMark	Frequency	Cortex Core	Special Features
High Performance	STM32H7	3224	480 MHz	Cortex-M7	Optimized for Mixed-signals applications
	STM32F2	398	120 MHz	Cortex-M3	
	STM32F4	608	180 MHz	Cortex-M4	
Mainstream	STM32G0	142	64 MHz	Cortex-M0+	Optimized for Mixed-signals applications
	STM32F0	106	48 MHz	Cortex-M0	
	STM32F1	177	72 MHz	Cortex-M3	
	STM32F3	245	72 MHz	Cortex-M4	Optimized for Mixed-signals applications
Ultra-low-power	STM32L0	75	32 MHz	Cortex-M0+	
	STM32L1	93	32 MHz	Cortex-M3	
	STM32L5	442	110 MHz	Cortex-M33	
	STM32L4+	409	120 MHz	Cortex-M4	Optimized for Mixed-signals applications
	STM32L4	273	80 MHz	Cortex-M4	
Wireless	STM32WB	216	32 MHz / 64 MHz	Cortex-M0+ / Cortex-M4	Optimized for Mixed-signals applications, Cortex-M0+ Radio Co-processor
	STM32WL	161	48 MHz	Cortex-M4	

Legend: ● Optimized for Mixed-signals applications ● Cortex-M0+ Radio Co-processor

## STM32 Solutions

-  Artificial Neural Networks
-  Graphic User Interface
-  STM32 Motor Control
-  STM32 Connectivity
-  STM32Cube Ecosystem
-  STM32 Community
-  STM32 Education

- ART Accelerator™ enabling 0 wait state executing from internal Flash
- Up to 2x USB2.0 OTG FS/HS (except for access lines)
- SDIO
- USART, SPI, I<sup>2</sup>C
- I<sup>2</sup>S + audio PLL
- 16 and 32-bit timers
- Up to 3x 12-bit ADC (0.41 μs)
- Up to 2x 12-bit DAC
- External memory controller
- Low voltage 1.71 to 3.6 V

STM32 F4	FCPU (MHz)	Flash (bytes)	RAM (KB)	Ethernet I/F IEEE 1588		Camera I/F	SDRAM I/F		SAI3 I/F	Chrom-ART Graphic Accelerator™	TFT LCD controller	MPI DSI		
				2x CAN			Dual Quad-SPI	SPDIF RX						
<b>Advanced lines</b>														
STM32F469 <sup>2</sup>	180	512 K to 2 M	384	•	•	•	•	•	•	•	•	•		
STM32F429 <sup>2</sup>	180	512 K to 2 M	256	•	•	•	•	•	•	•	•	•		
STM32F427 <sup>2</sup>	180	1 to 2 M	256	•	•	•	•	•	•	•	•	•		
<b>Foundation lines</b>														
STM32F446	180	256 K to 512 K	128	•	•	•	•	•	•	•	•	•		
STM32F407 <sup>2</sup>	168	512 K to 1 M	192	•	•	•	•	•	•	•	•	•		
STM32F405 <sup>2</sup>	168	512 K to 1 M	192	•	•	•	•	•	•	•	•	•		
Product lines	FCPU (MHz)	Flash (Kbytes)	RAM (KB)	RUN current (μA/MHz)	STOP current (μA)	Small package (mm)	FSMC (NOR/PSRAM/LCD support)	QSPI	DFSDM	CAN 2.0B	DAC	TRNG	DMA Batch Acquisition Mode	USB 2.0 OTG FS
<b>Access lines</b>														
STM32F401	84	128 to 512	up to 96	Down to 128	Down to 10	Down to 3x3								•
STM32F410	100	64 to 128	32	Down to 89	Down to 6	Down to 2.553x 2.579					•	•	BAM	-
STM32F411	100	256 to 512	128	Down to 100	Down to 12	Down to 3.034x 3.22							BAM	•
STM32F412	100	512 to 1024	256	Down to 112	Down to 18	Down to 3.653x 3.651	•	•	•	•		•	BAM	• +LPM <sup>4</sup>
STM32F413 <sup>2</sup>	100	1024 to 1536	320	Down to 115	Down to 18	Down to 3.951x 4.039	•	•	•	•		•	BAM	• +LPM <sup>4</sup>

Notes:

1. 1.7 V min on specific packages
2. The same devices are also found with embedded HW AES encryption (128-/256-bit) named STM32F423
3. Serial Audio Interface
4. Link Power Management

Flash size / RAM size (bytes)



ARM® Cortex®-M4 (DSP + FPU) – Up to 180 MHz • ART Accelerator™ • SDIO • USART, SPI, I²C • I²S + audio PLL • 16 and 32-bit timers • 12-bit ADC (0.41 μs) • True Random Number Generator • Batch Acquisition Mode • Low voltage 1.7 to 3.6 V • Temperature: • -40 °C to 125 °C	Access lines	FCPU (MHz)	Flash (Kbytes)	RAM (KB)	RUN current (μA/MHz)	STOP current (μA)	Small package (mm)	FSMC (NOR/PSRAM/LCD support)	QSPI	DFSDM	CAN 2.0B	DAC	TRNG	DMA Batch Acquisition Mode	USB 2.0 OTG FS	
	STM32F401	84	128 to 512	up to 96	Down to 128	Down to 10	Down to 3x3									•
	STM32F410	100	64 to 128	32	Down to 89	Down to 6	Down to 2.553x 2.579					•	•	BAM		-
	STM32F411	100	256 to 512	128	Down to 100	Down to 12	Down to 3.034x 3.22								BAM	•
	STM32F412	100	512 to 1024	256	Down to 112	Down to 18	Down to 3.653x 3.651	•	•	•	•			•	BAM	• +LPM¹
	STM32F413²	100	1024 to 1536	320	Down to 115	Down to 18	Down to 3.951x 4.039	•	•	•	•			•	BAM	• +LPM¹

Notes:

1. Link Power Management
2. The same devices are also found with embedded HW AES encryption (128-/256-bit) named STM32F423

# STM32F401RE

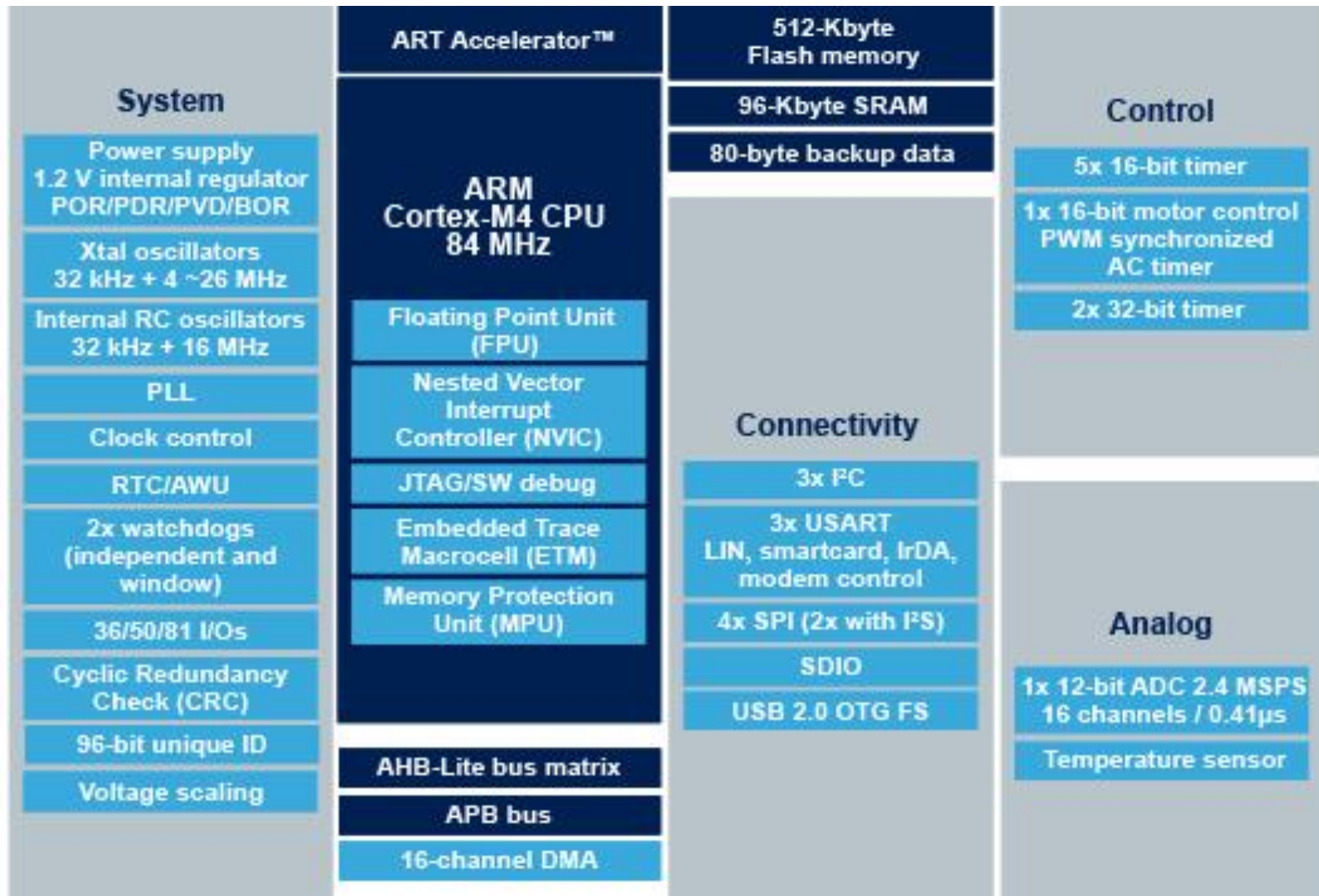

# Interruptions

- 16 ARM Cortex M4
- 52 lignes d'interruption masquables (NVIC)
- 16 niveaux de priorité

# Interruption / événement

- Une interruption coupe l'exécution du programme
- La plupart des routines d'interruption peuvent/doivent être reprogrammées
- Un événement n'interrompt pas le programme
- Il permet de déclencher l'action d'un autre périph. sans intervention du «CPU»

# DMA

- Accès direct à la mémoire au lieu d'interrompre le CPU

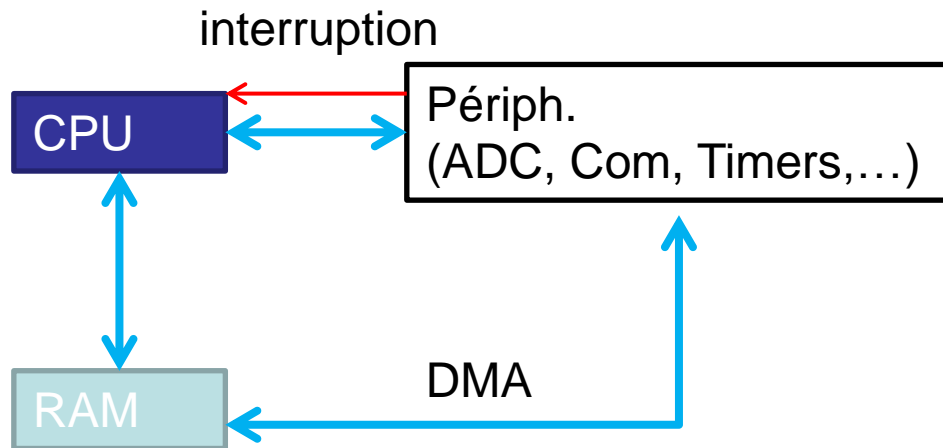

# Conclusion

- Unité de calcul
- Périphériques
- Interruptions
- DMA