

EPFL



MICRO-435 Quantum and Nanocomputing

Edoardo Charbon
Mariagrazia Graziano

NANOMAGNETIC CIRCUITS

I-NHL

CIRCUITS & PHASES

LOGIC GATES

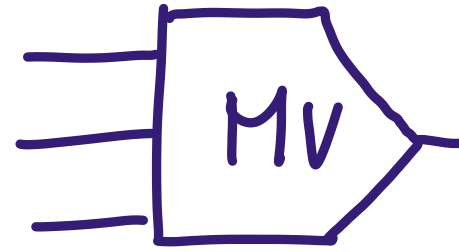

MAJORITY
VOTER

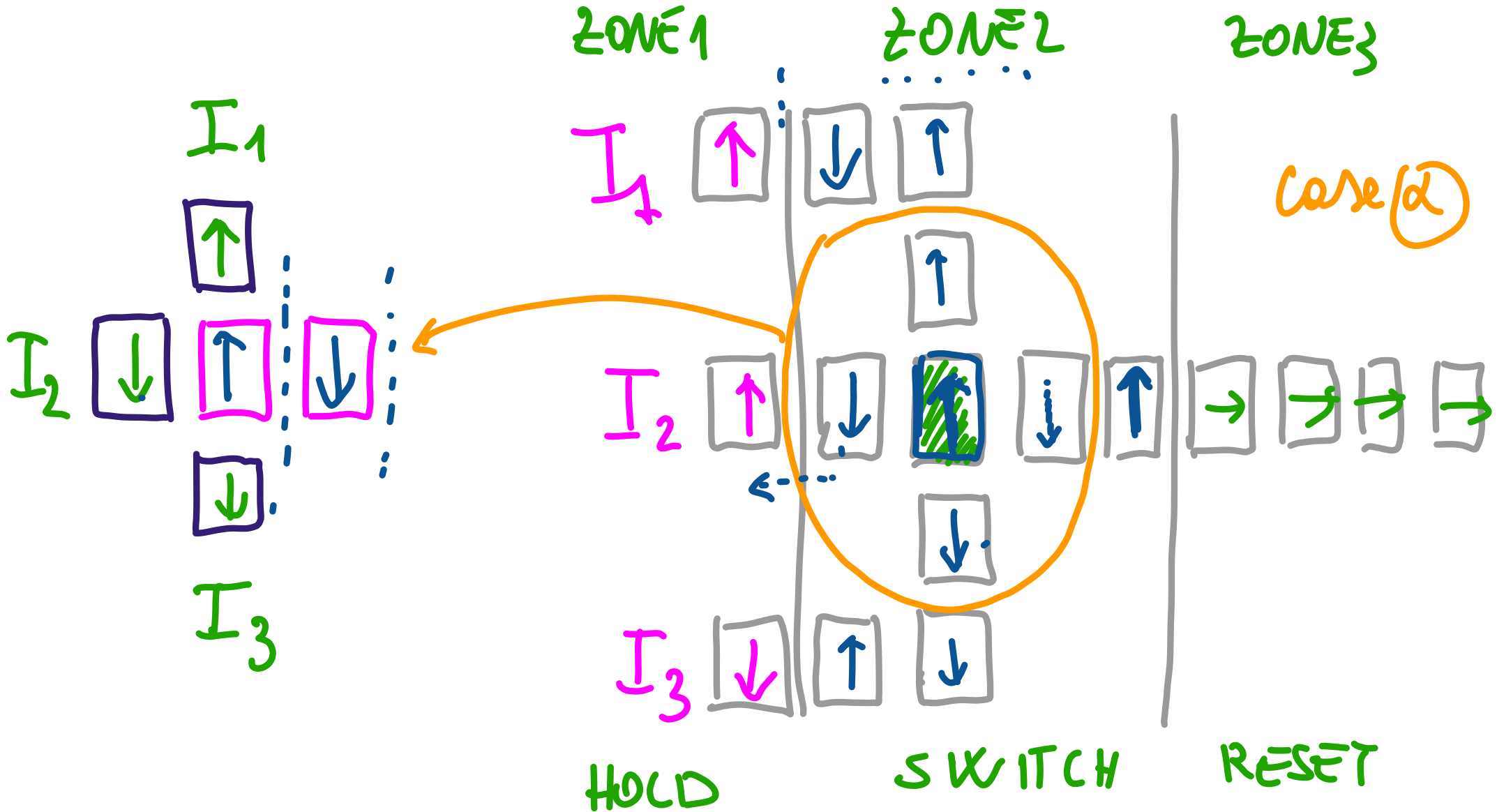

Case β



Case γ

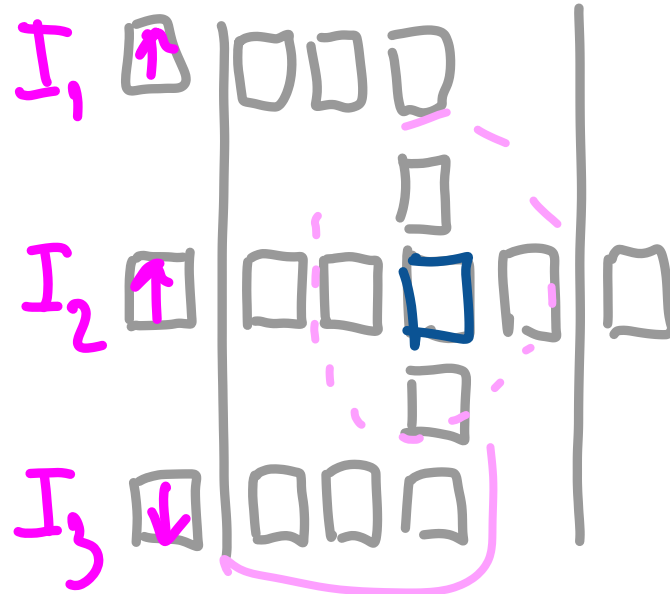

Case δ

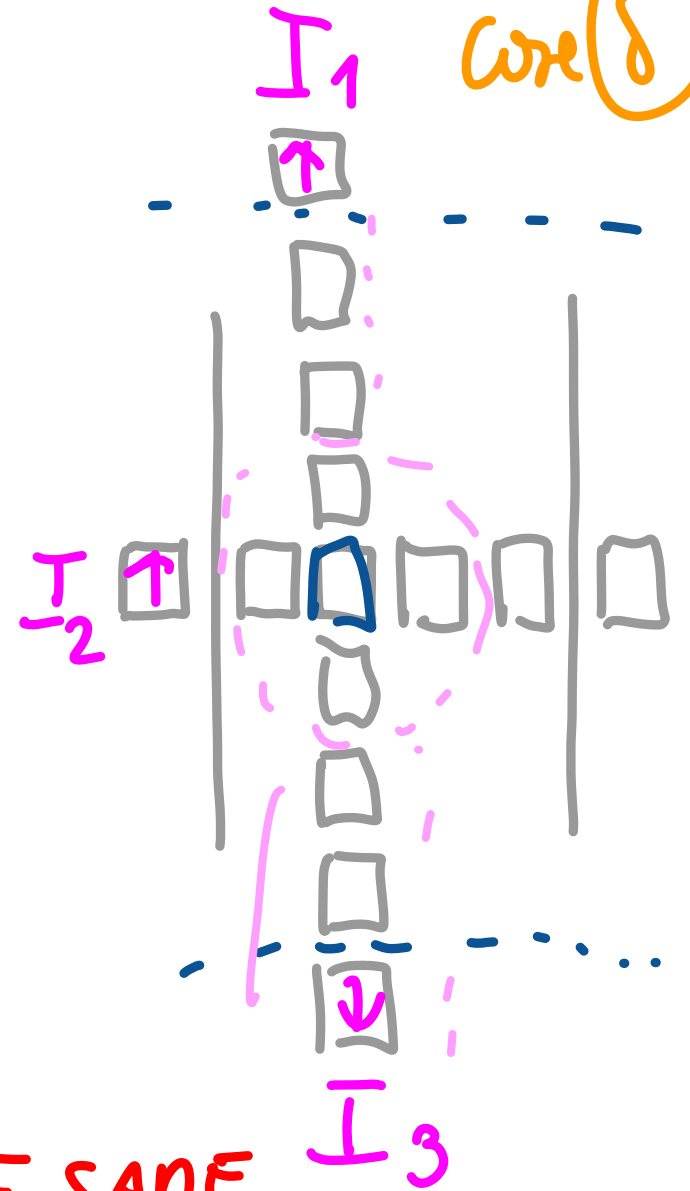

ACTIVE

VERIFY CASES β, γ, δ :

ARE THEY SAME AS α ? WHICH ONE IS BETTER?

M.V. WORKS BETTER IF VIRTUAL CLOCK IS USED

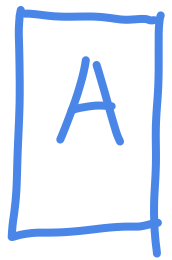
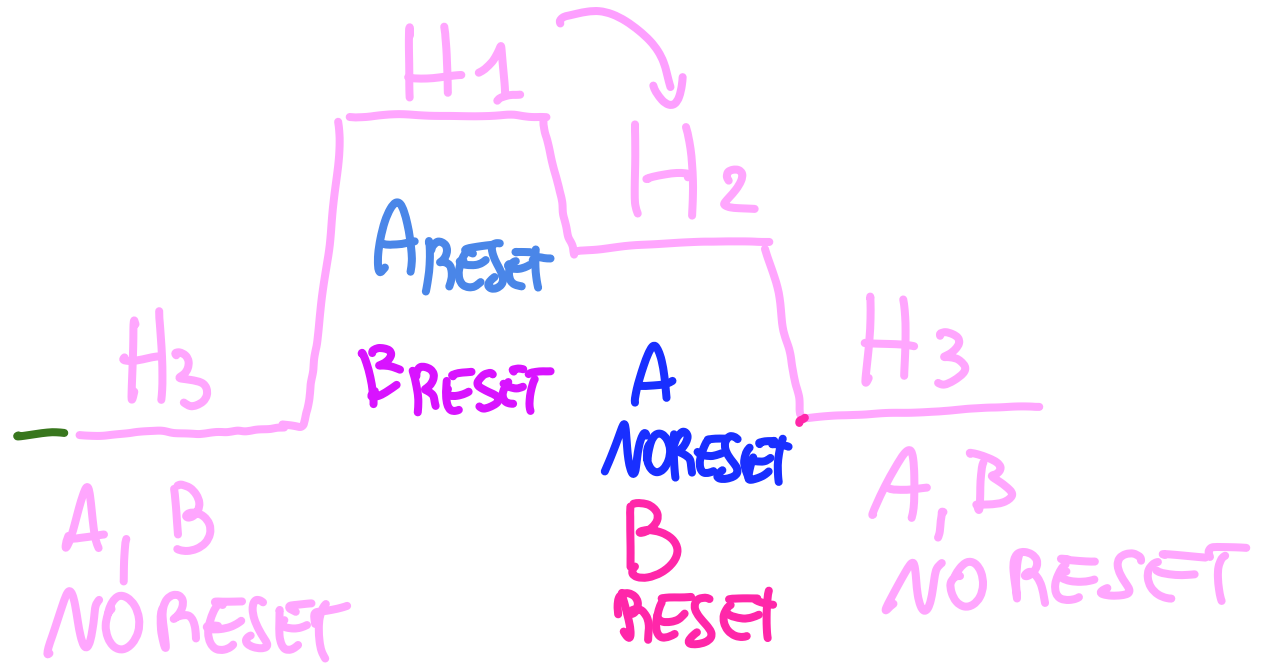
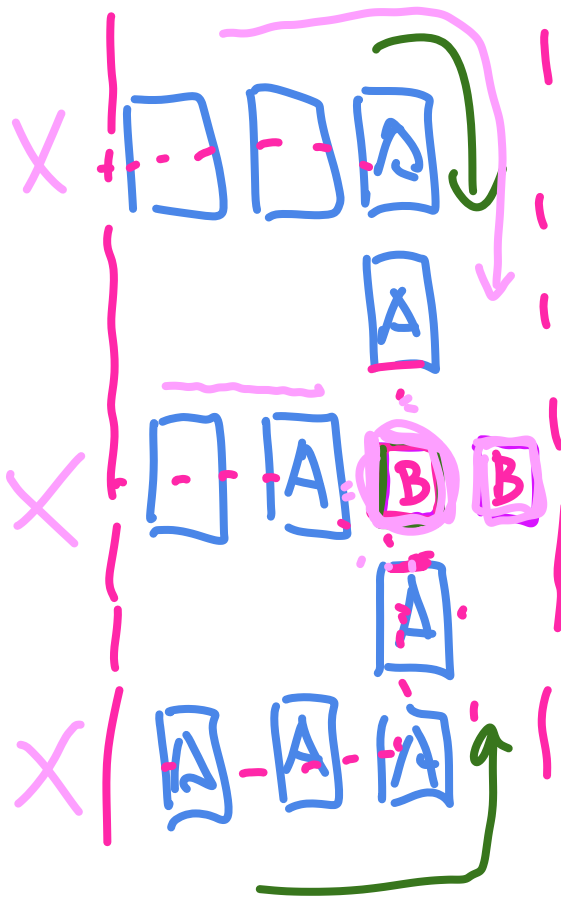

REQUIRES SMALLER H FOR RESET

DIFFERENTI- A.R.

H₃ hold old values Π

H₁ MV all in RESET

H₂ B magnet RESET
A pos'n SWITCH

H₂ REL., H₃, B SWITCHES

MICROMAGNETIC SIMULATION OF VIRTUAL CLOCK - M.V.

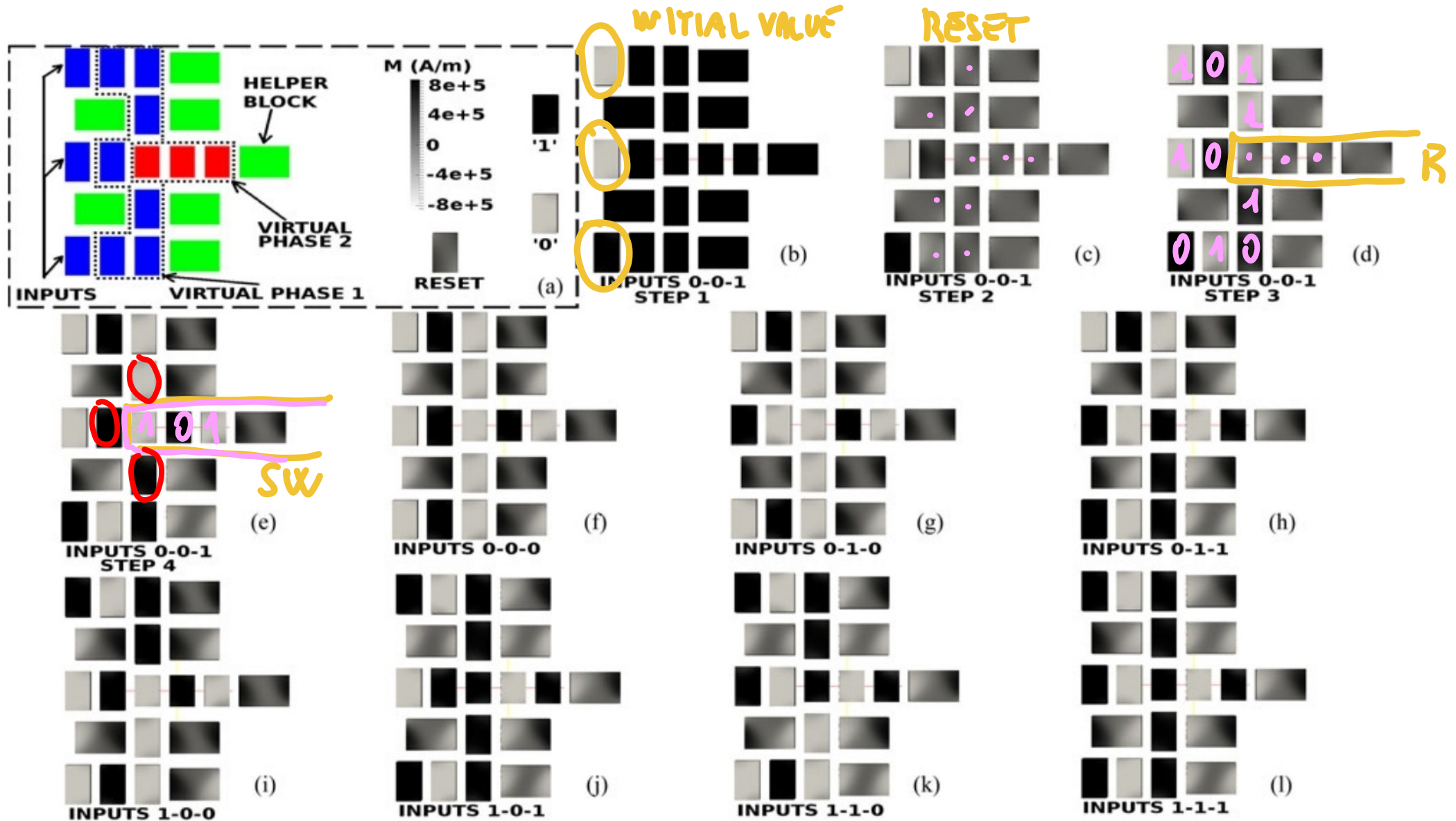
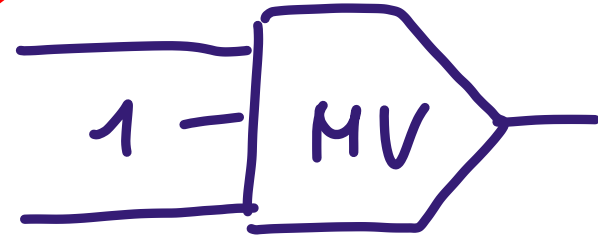

Fig. 5. Majority voter with Virtual Clock. a) Gate layout. The three input wires are in the first virtual clock phase, while the other magnets are in the second virtual clock phase. Helper blocks are required to assure a correct propagation of signals. b) Simulation with inputs equal to 0-0-1. Magnets are initialized to logic '1'. c) Magnets are then forced in the RESET state. d) When the magnetic field start to be removed, only the input wire magnets switch. e) Finally also the central and output magnets switch correctly. f) Final state with inputs equal to 0-0-0. g) Final state with inputs equal to 0-1-0. h) Final state with inputs equal to 0-1-1. i) Final state with inputs equal to 1-0-0. j) Final state with inputs equal to 1-0-1. k) Final state with inputs equal to 1-1-0. l) Final state with inputs equal to 1-1-1.

MV →

AND, OR

homework
↑
verify



NOT THE ONLY WAY TO DO
AND, OR

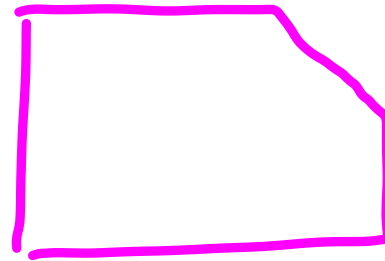
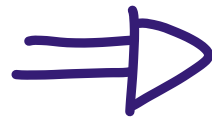
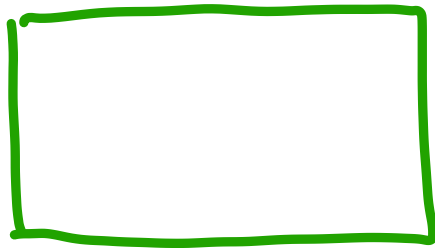

RECTANGULAR
MAGNETS
CUT IN ONE
CORNER TO



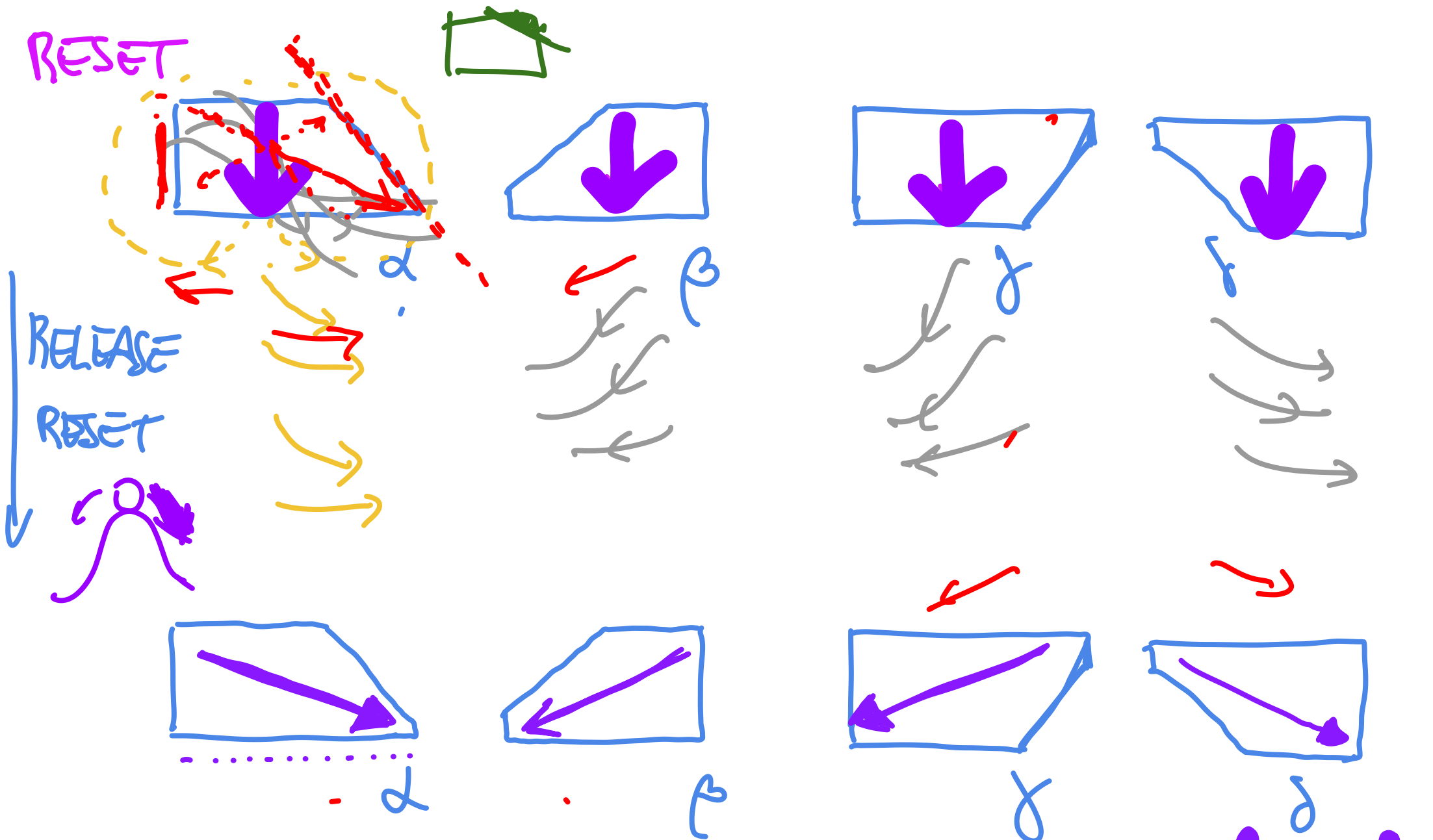

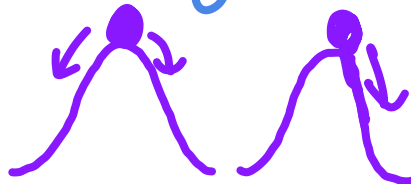

FAVOUR MAGNETIZATION



EASY AXYS WITH WCLINATION
 ONE DIRECTION FAVOURED By CUT



ANOTHER WAY TO DO LOGIC

IN1		1	0	1	
			1	1	
IN2			1	1	
IN1		1	0	1	0
					
IN2		0	1	1	0

Verify the side of the CUT

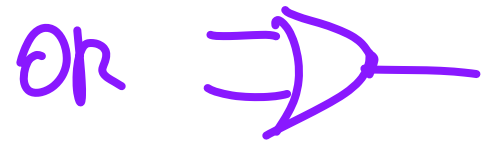

ACTIVE
VERIFY!

AND



INVERTER

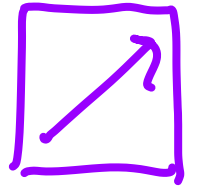
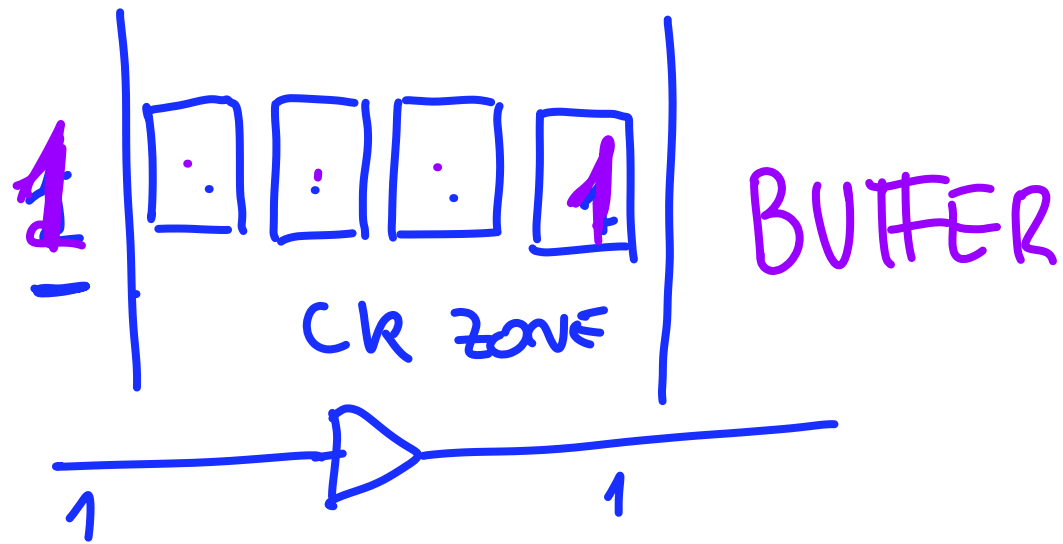

PLAY

-> D.A.R.

-> DISTANCES

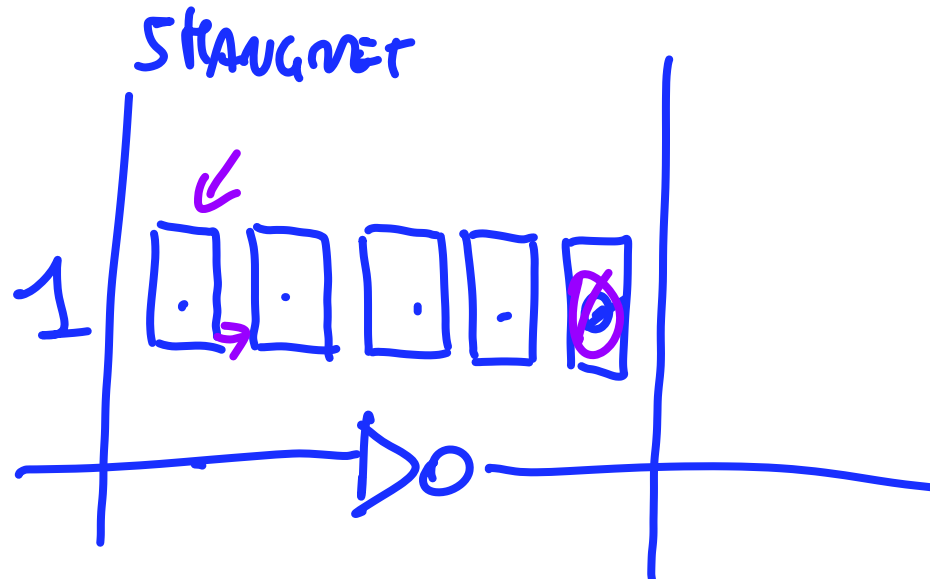

BETTER

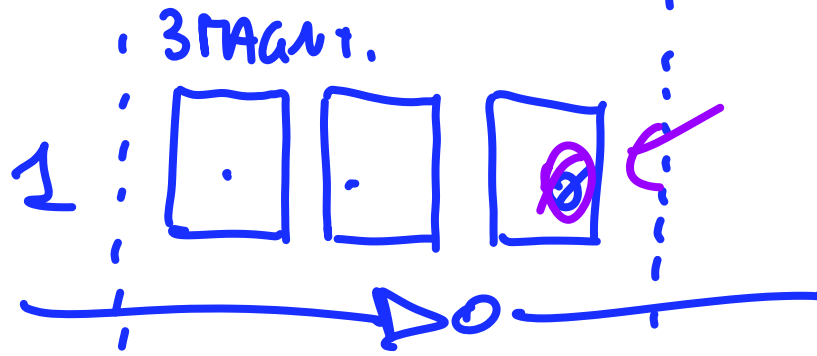

WAY 1

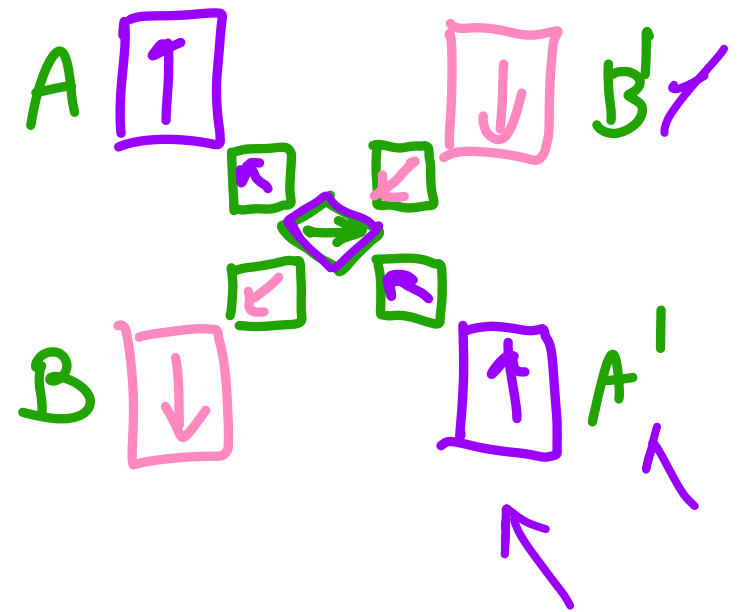
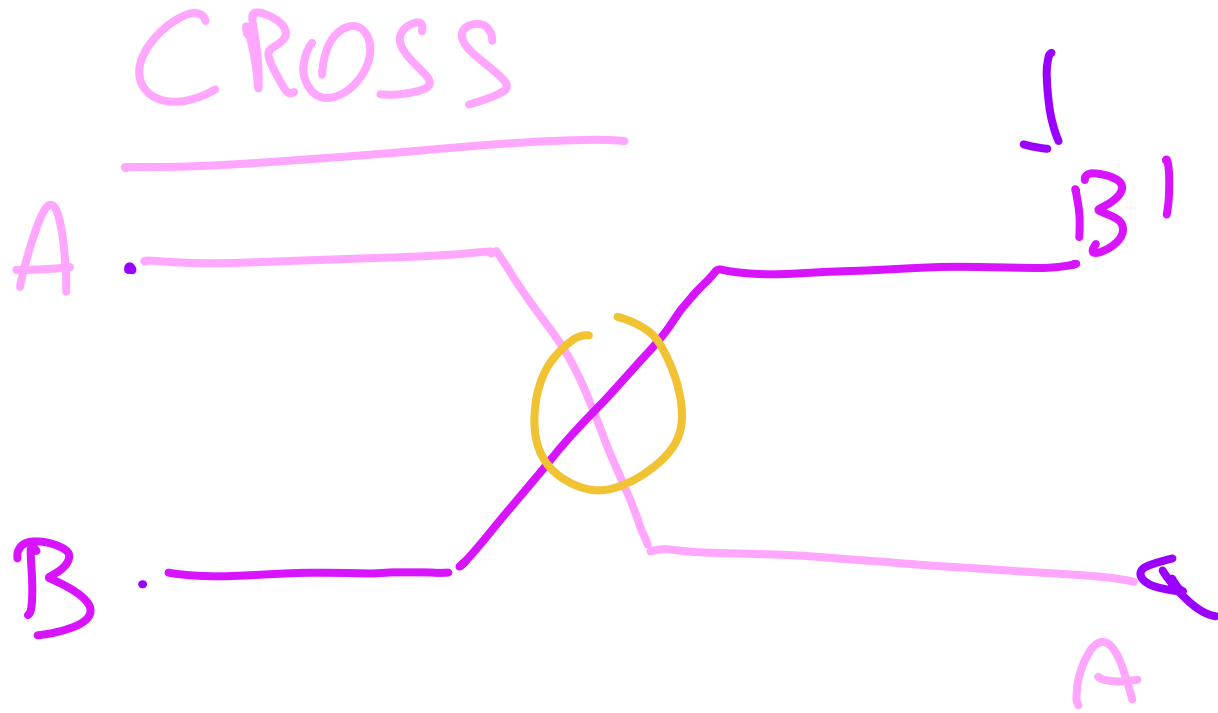

WAY 2

SECTION VIEW

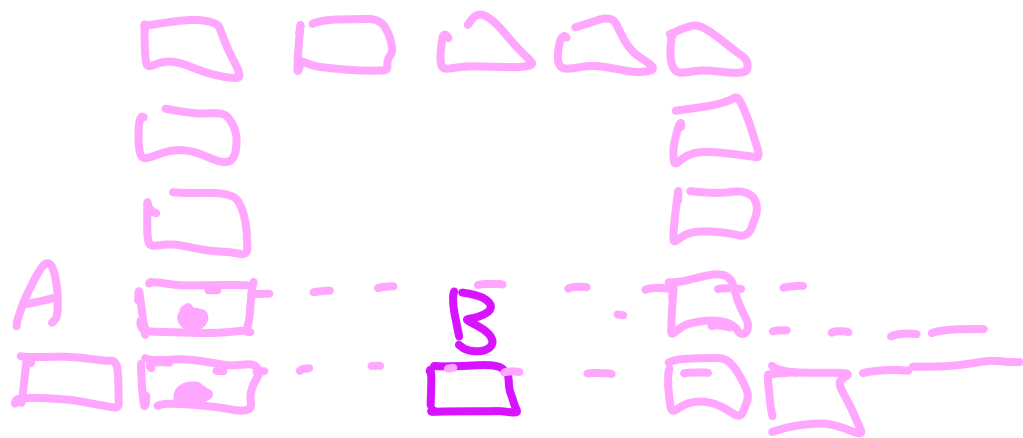

TOP VIEW

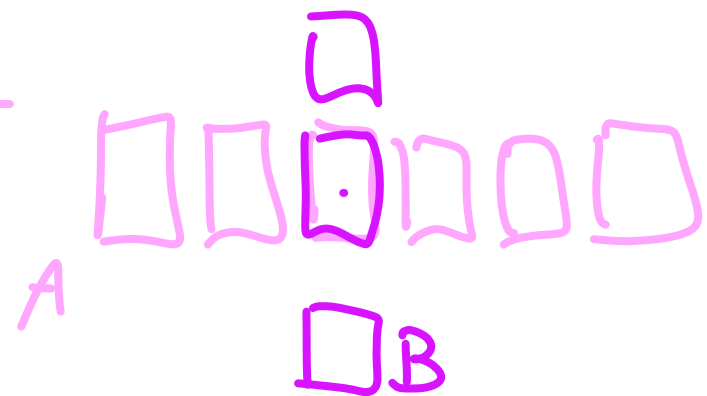

OBJECTIVES

I-NMML CIRCUITS

EXERCISES

EXAMPLES

EX. (1)

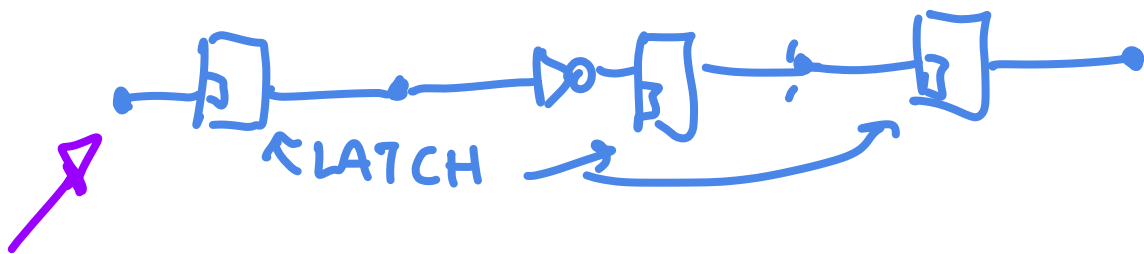
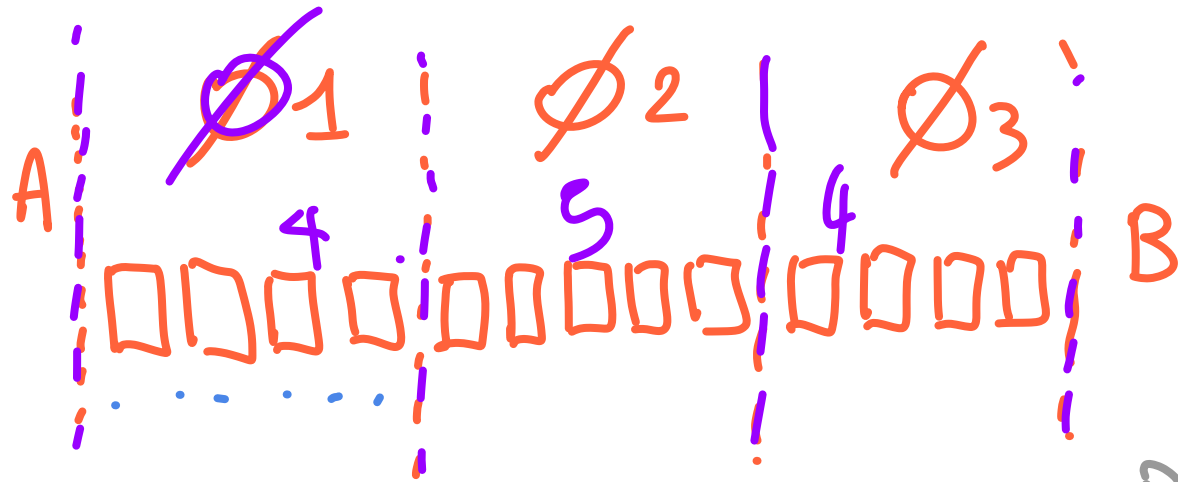
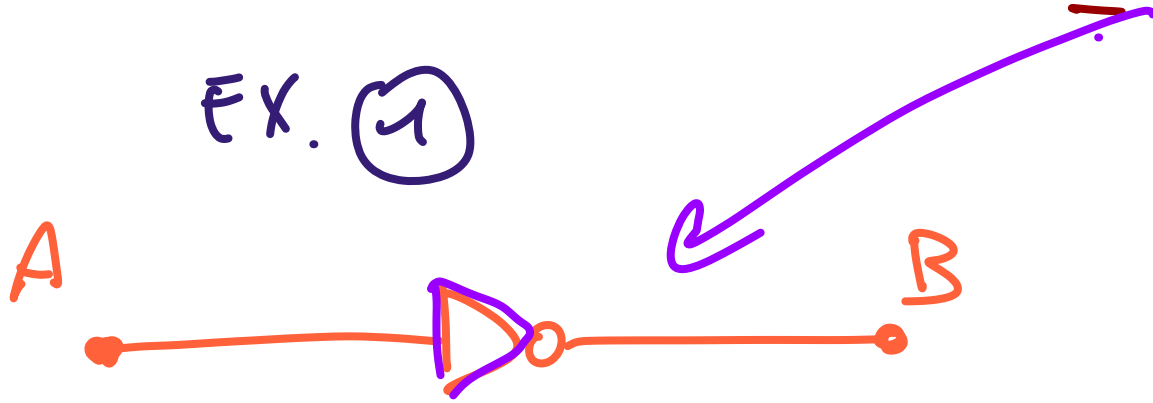

DESIGN LAYOUT
4 MAGNETS \checkmark
ZONE
3 ZONES

EQUIVALENT LOGIC
CIRCUIT

MORE CORRECT MODEL
TAKING INTO ACCOUNT
SYNCHRONIZATION

EXAMPLE 2

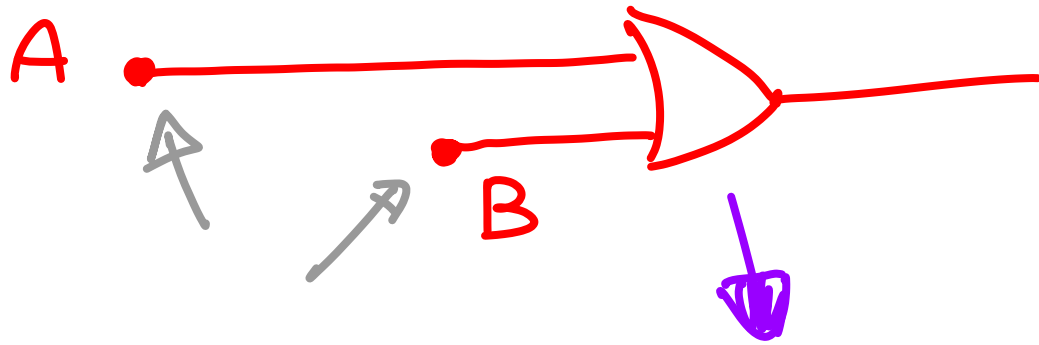

LAYOUT = TIMING

PAY ATTENTION TO SKEW / DESKEW NETS.

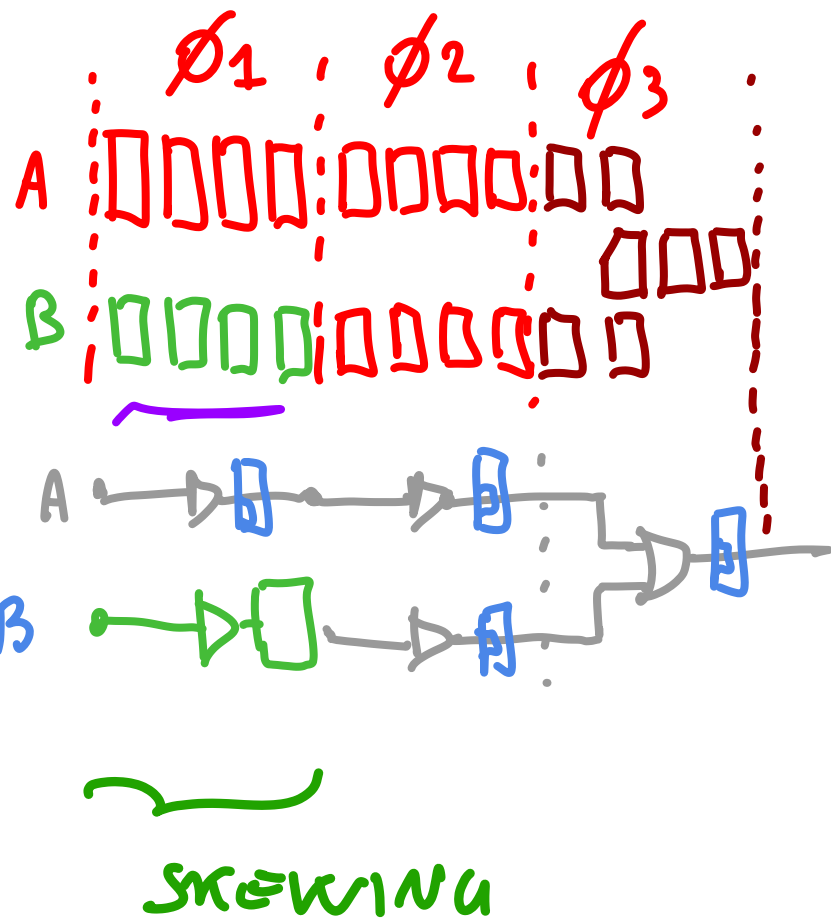
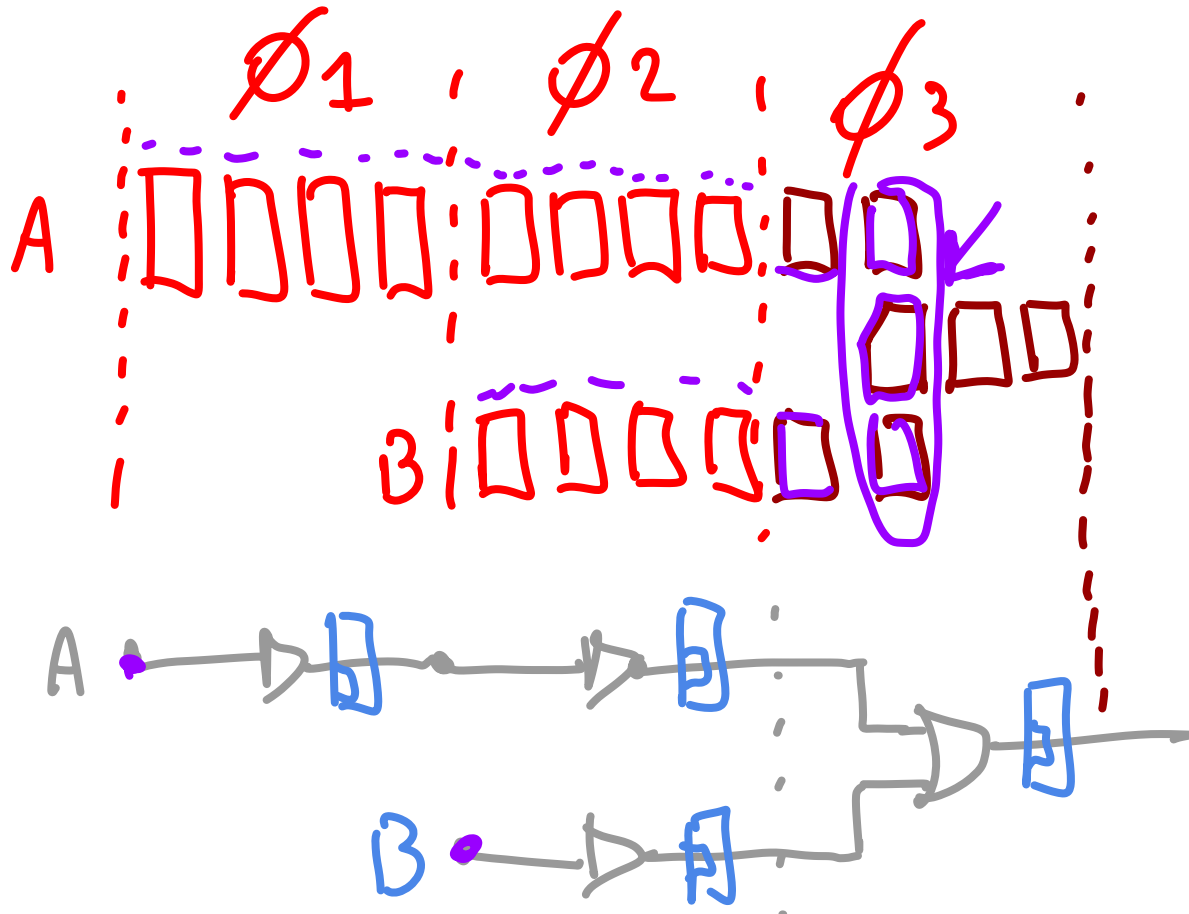

EXAMPLE (3)

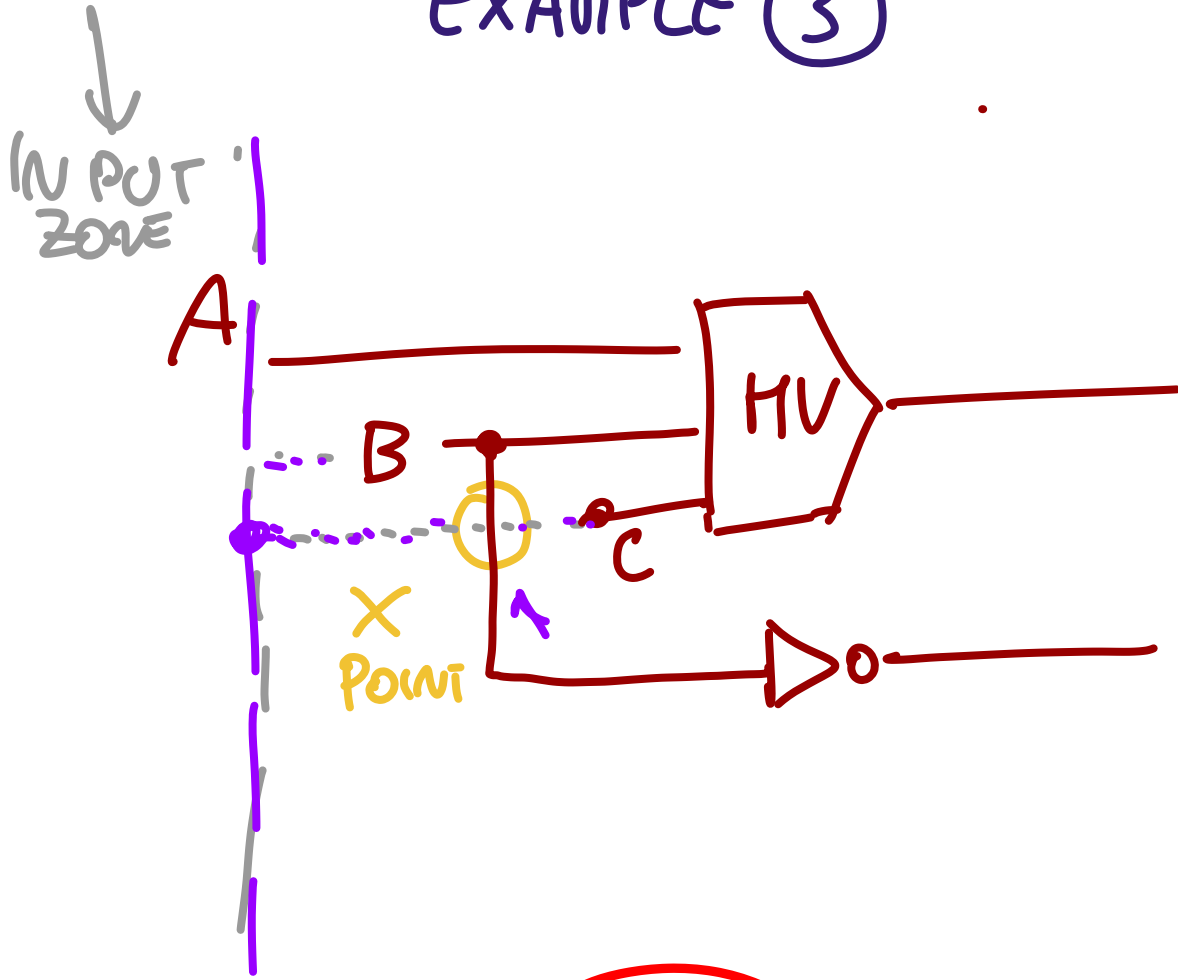

ACTIVE

- COMPENSATE LATENCY (SKEW)

- USE CROSSWIRE

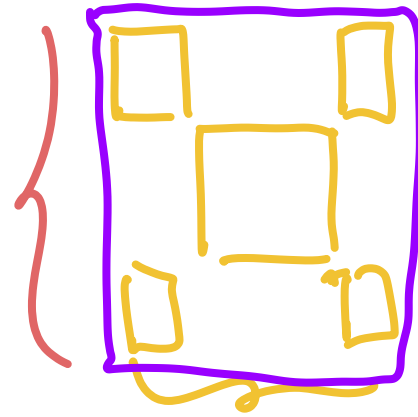

4 MAGNETS

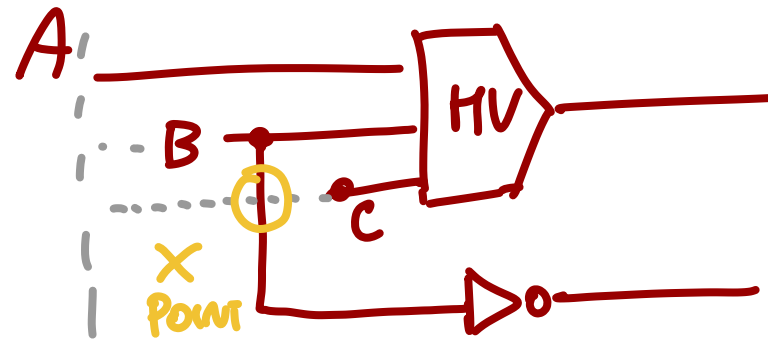

EXAMPLE (EXERCISES)

④

HALF-ADDER

H.A.

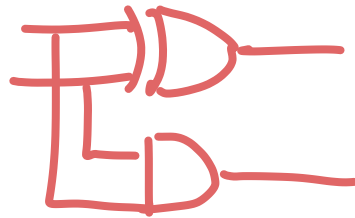

4.1 WITH M.V.

4.2. WITH CUT
MAGNETS

⑤

FULL-ADDER (FA) USING 2 H.A.

⑥

3 bits RIPPLE-CARRY-ADDER (RCA)

WITH INPUT FROM SAME ZONES

SCALING UP TO BIG CIRCUITS

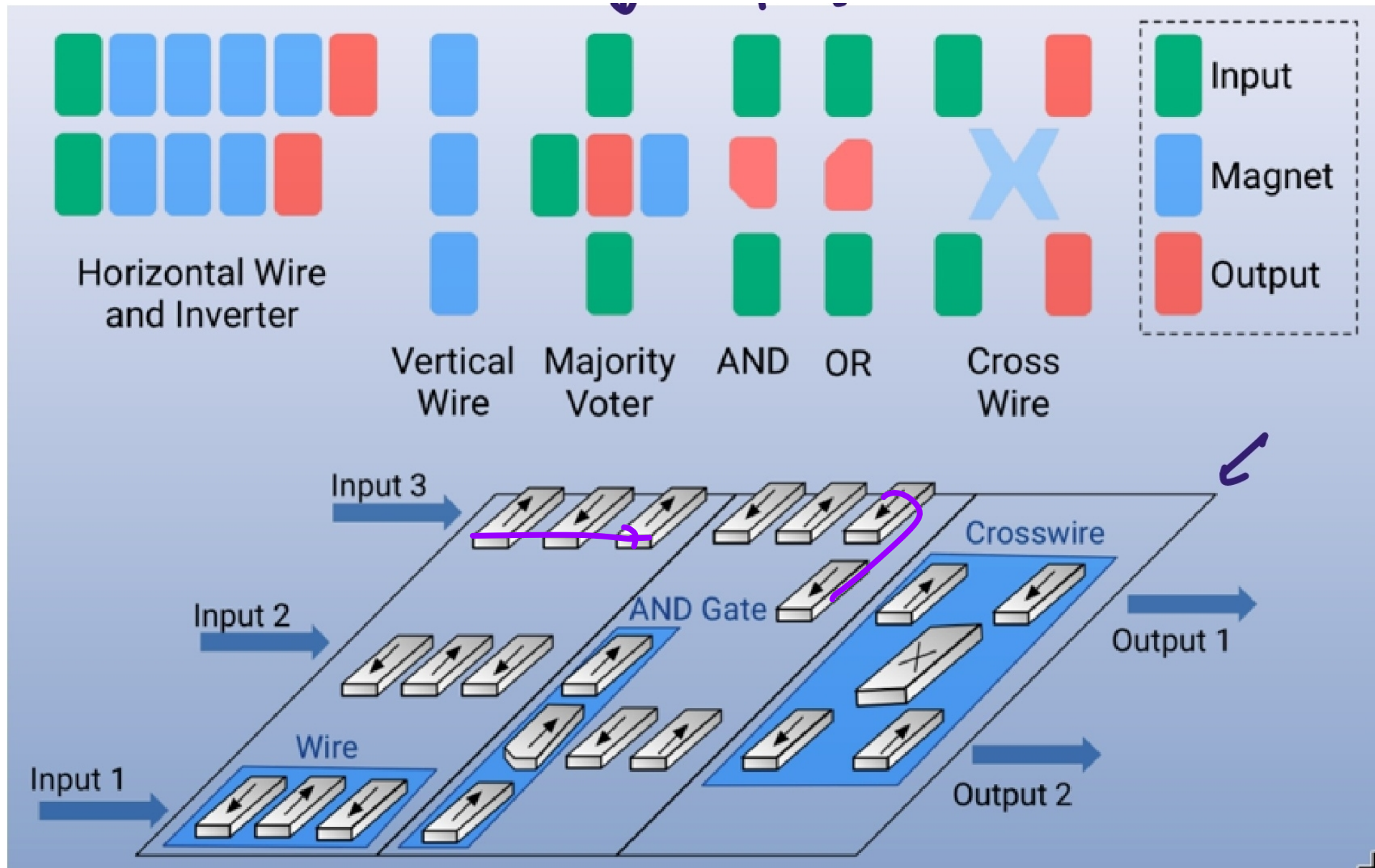

IN A STANDARD CIRCUIT

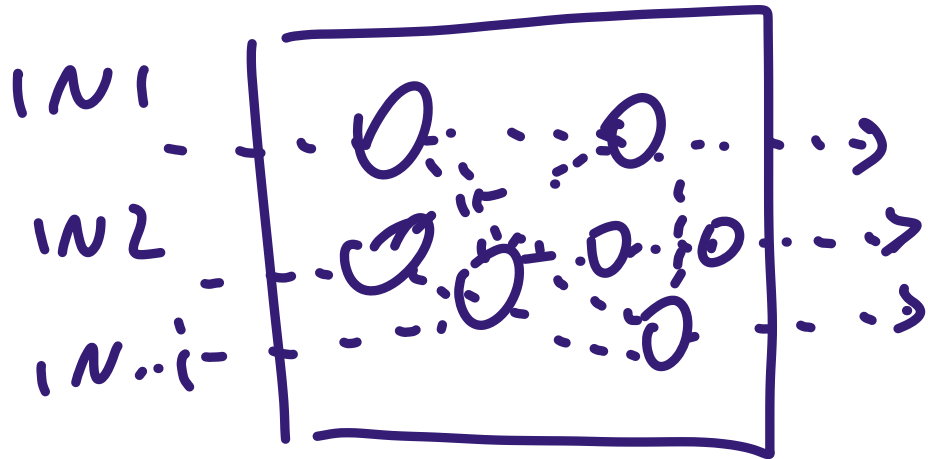

INFORMATION PROPAGATES
IN ALL DIRECTIONS
(NO α , WE HAVE 20
METAL LAYERS...
EASY GATE)

WHAT IN 1-NHL?

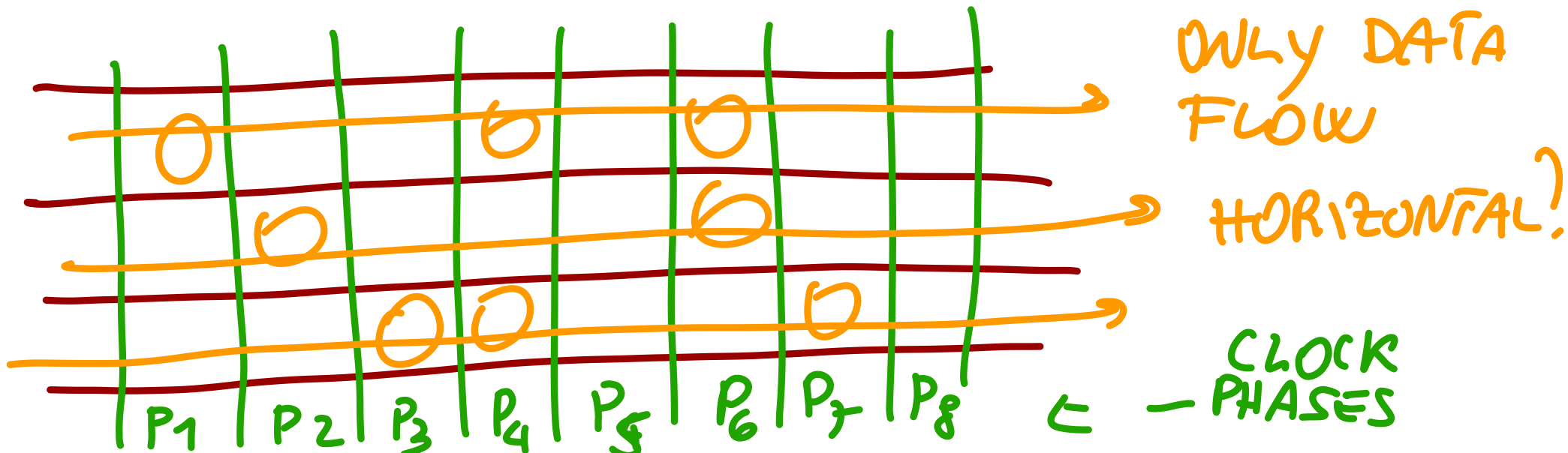

HOW TO DELIVER CLOCK IN BIGGER CIRCUITS : SNAKE CLOCK

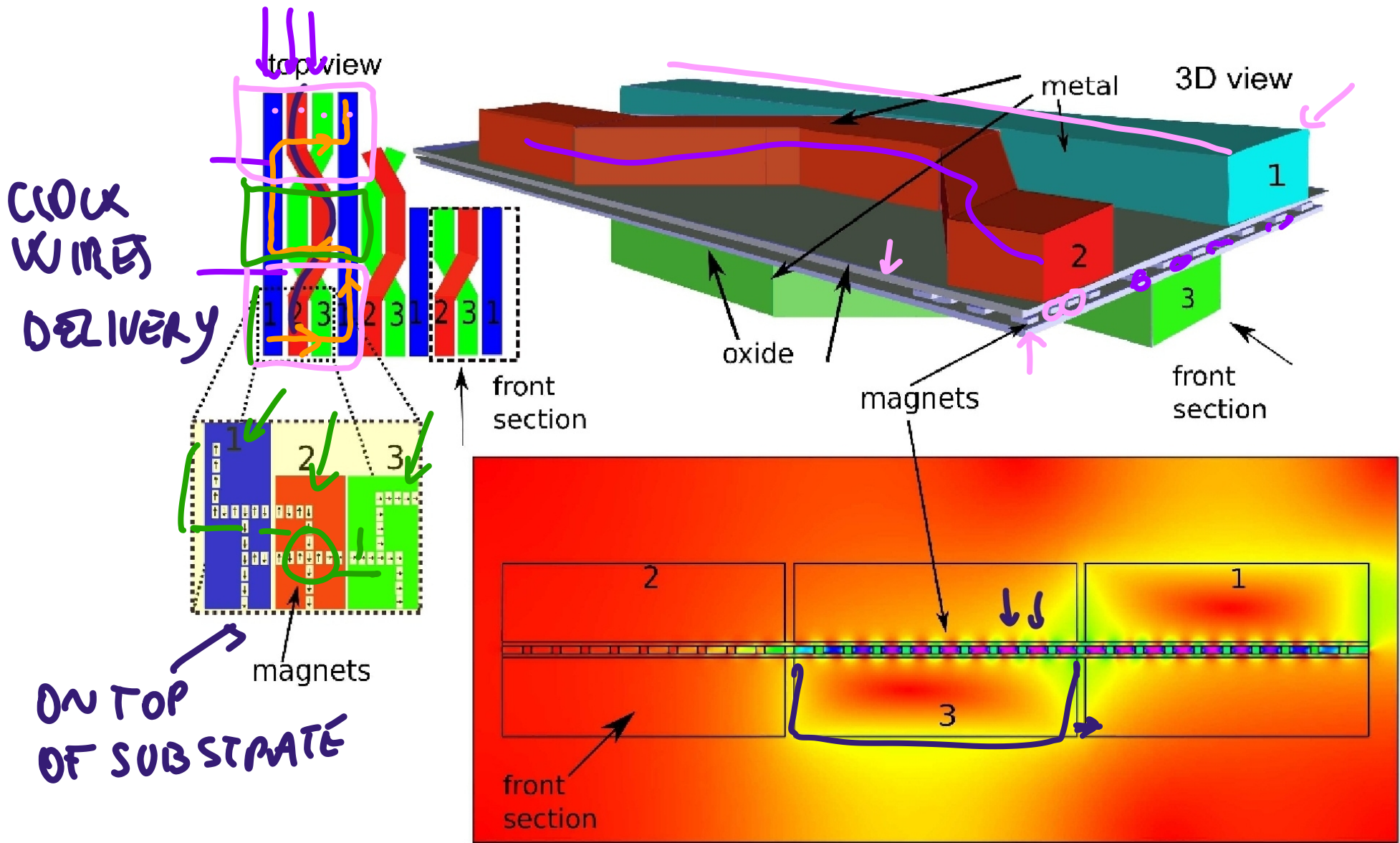

→ Comsol Multiphysics simulation - clock distribution

A POSSIBILITY: SNAKE CLOCK AS
EXAMPLE TO ADAPT A TECH. LIMIT TO...

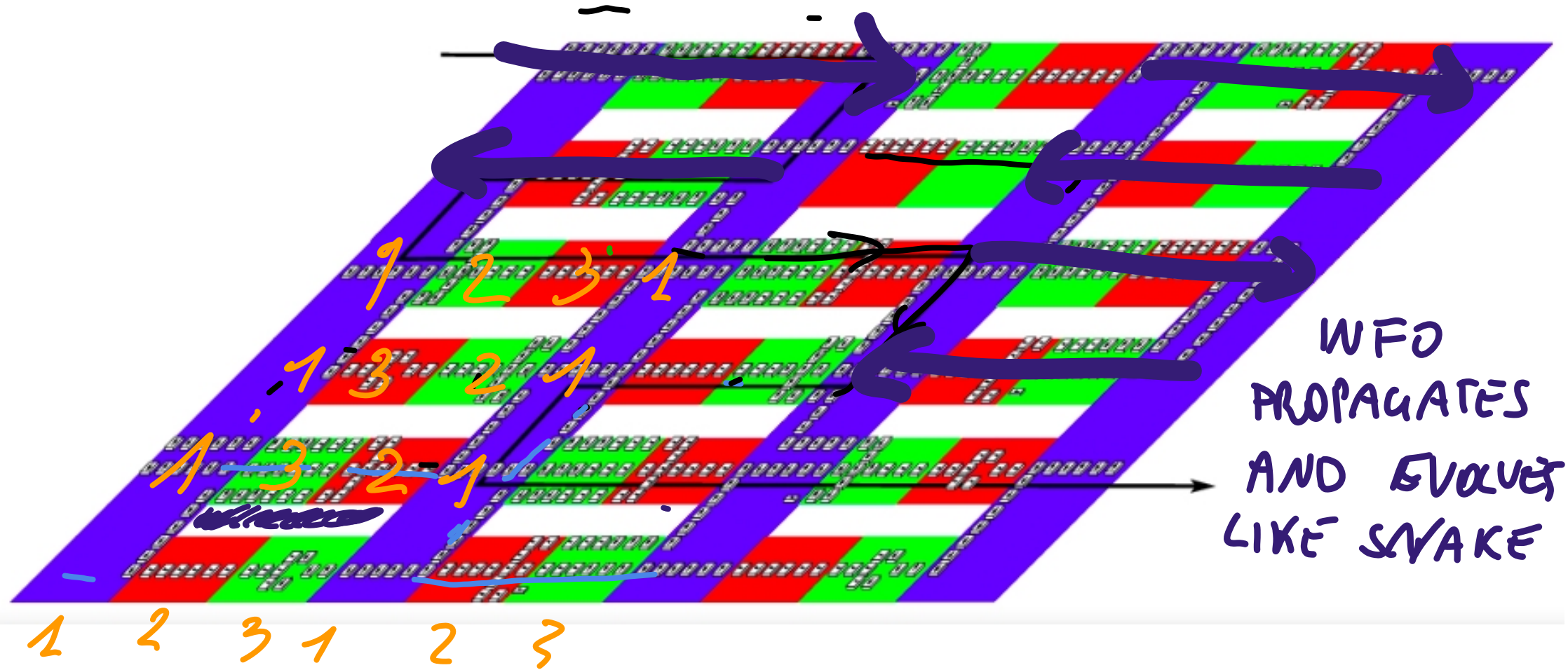

..... A REAL NECESSITY: BIGGER CIRCUITS
AND COMPLEX INFO PROPAGATION

FEM ANALYSIS OF M.F. APPLIED

PHASES PARTIALLY SUPERPOSED

Control mutation impact on magnets of applied make clock

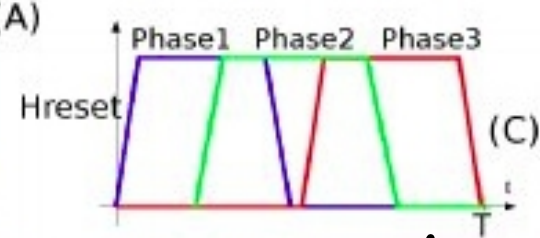
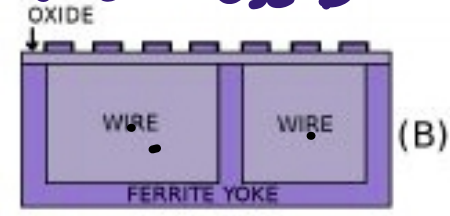
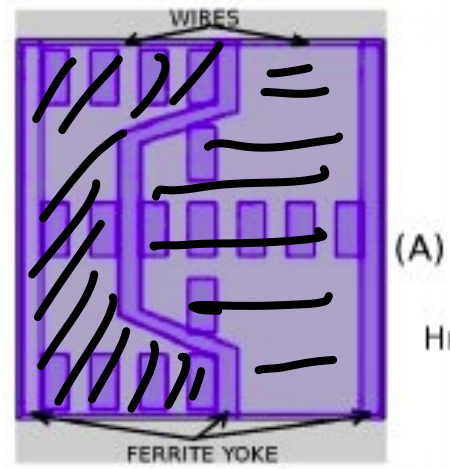

RESET APPLIED TO PHASE 1

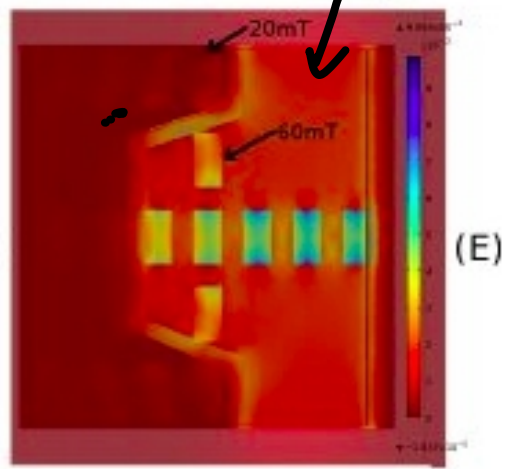
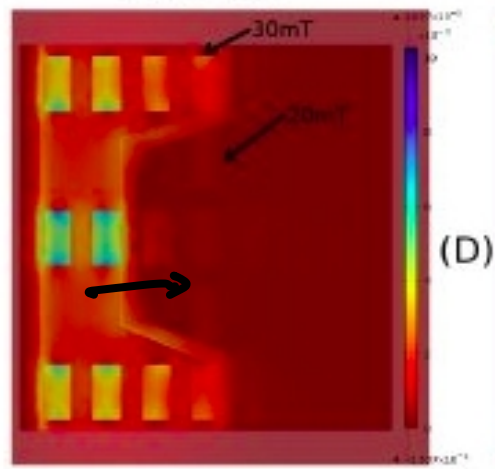

RESET APPLIED TO PHASE 2

MAGN. ALONG HARD AXIS IN P. 1

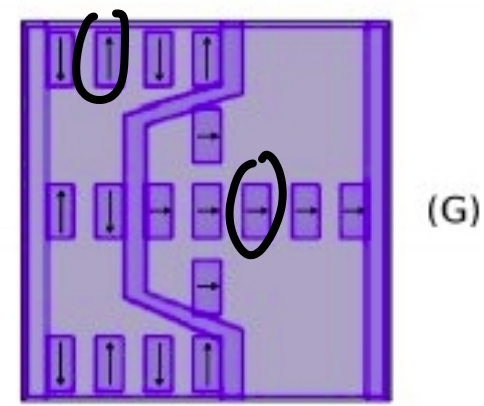
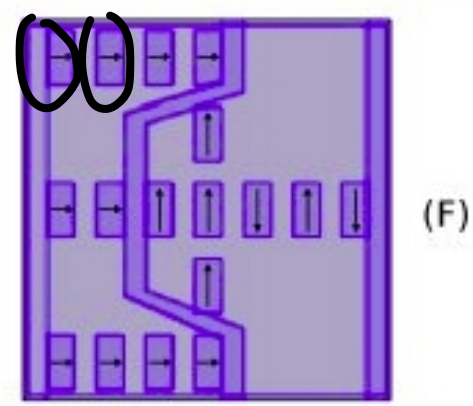

MAGN. ALONG HARD AXIS IN P2, INFO IN P. 1

EVAL IN P. 2

HOW TO DESIGN GATES AND SIMULATE THEM logic gates micromagnetic simulations (MAGSIMS)

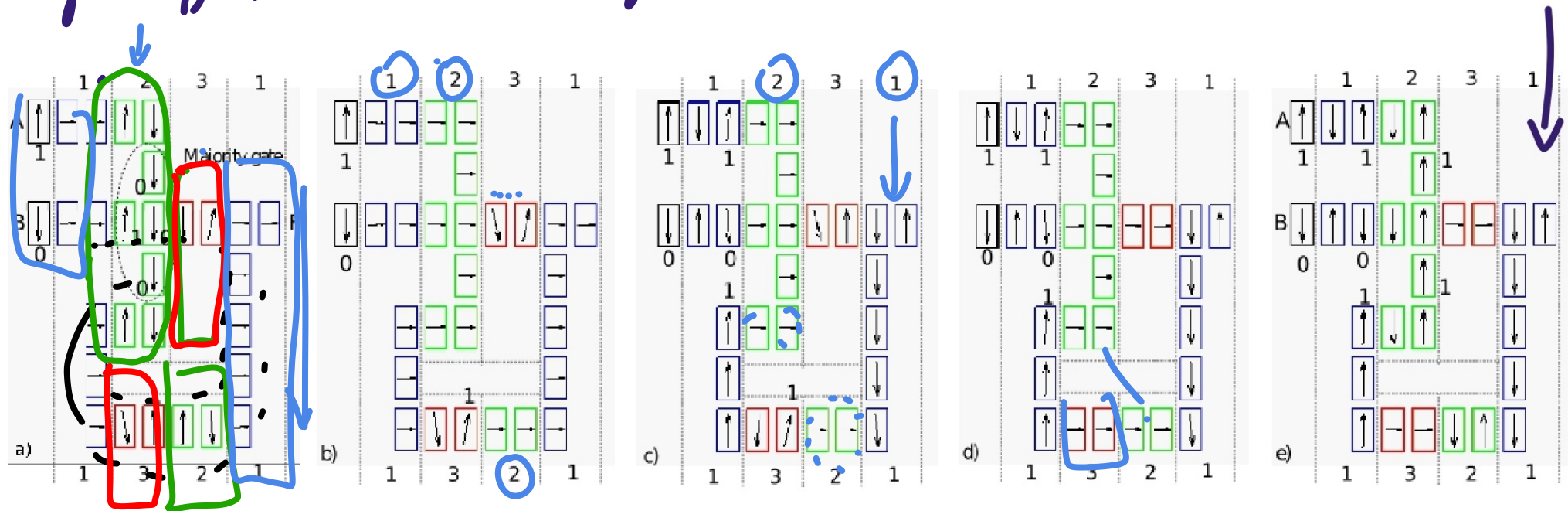

Micromagnetic simulations (MAGSIMS) of a LOGIC GATE
....

→ Null Convention Logic: a solution to layout=timing constraint which is associated to NanoMGneticLogic intrinsic micropipelining

Here NCL-TH22

$$F = AB + F(A+B)$$

snake clock application, micromagnetic simulation in time

HOW TO DESIGN BIG CIRCUITS AND SIMULATE THEM

logic simulation

conceptual model

symbol

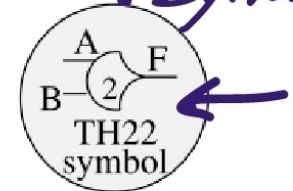
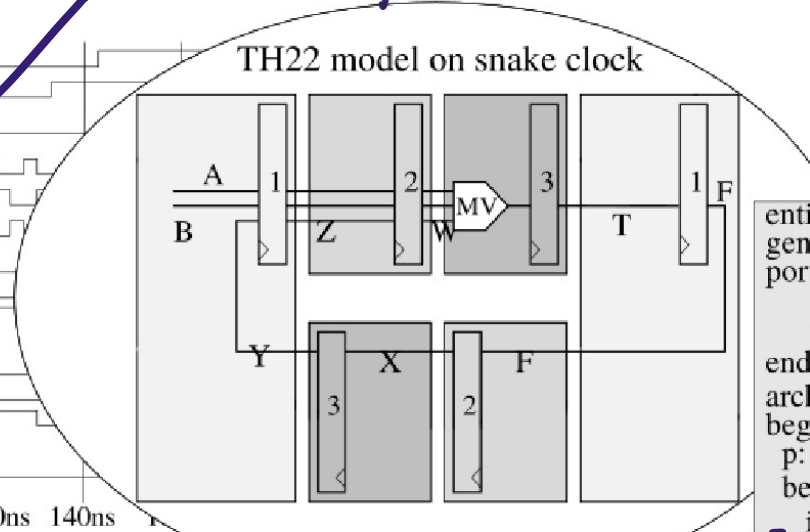
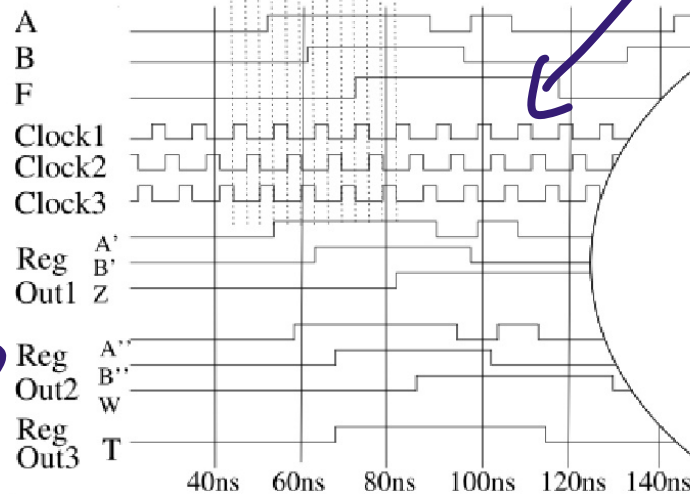

```
entity reg is
generic (nbit: integer :=32);
port (din: in std_logic_vector (nbit-1 downto 0);
      dout: out std_logic_vector (nbit-1 downto 0);
      reset, clock: in std_logic);
end reg;
architecture behav of reg is
begin
p: process (clock, reset)
begin
-- Register
if reset = '1' then
dout <= (others => '0');
elsif (clock'event and clock='1') then
dout <= din;
end if;
end process;
end behav;
```

```
entity TH22 is
port (A,B, clk1,clk2,clk3: in std_logic; F: out std_logic);
end TH22;
architecture behav of TH22 is
.....components declaration of MV and Register gates.....
signal MVO, T, P, X, Y : std_logic; signal Z, W : std_logic_vector(2 downto 0);
begin
R1 reg: generic map (nbit=>3) port map (din(0)=>A, din(1)=>B, din(2)=>Y, dout=>Z, reset='0', clk=>clk1);
R2 reg: generic map (nbit => 3) port map (din=>Z, dout=>W, reset = '0', clk=>clk2);
M1 mv: port map (a=>W(0), b=>W(1), c=>W(2), y=>MVO);
R3 reg: generic map (nbit => 1) port map (din=>MVO, dout=>T, reset = '0', clk=>clk3);
R4 reg: generic map (nbit => 1) port map (din=>T, dout=>P, reset = '0', clk=>clk1);
R5 reg: generic map (nbit => 1) port map (din=>P, dout=>X, reset = '0', clk=>clk2);
R6 reg: generic map (nbit => 1) port map (din=>X, dout=>Y, reset = '0', clk=>clk3);
F<=P;
end behav;
```

TH22 VHDL model

```
entity mv is
port(a,b,c: in std_logic);
end mv;
architecture behav of mv is
begin
y <= (a and b)or(a and c)or(b and c);
end behav;
```

VHDL model of TH22

RISC PROCESSOR SIMULATED

+

BIOSEQUENCE PROCESSOR DESIGNED

& SIMULATED



IT WORKS

~ 400 MHz



ARCH. TECHNIQUES
USED TO SOLVE

NO
MULTILAYER
YET



LARGE
AREA

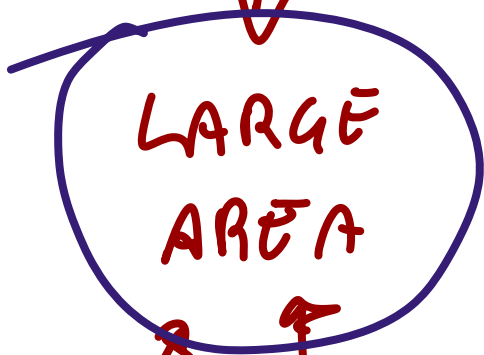

NO LEAKAGE
BUT

POWER FOR CLOCK
DUE TO

LESSONS LEARNED!

EXAMPLES

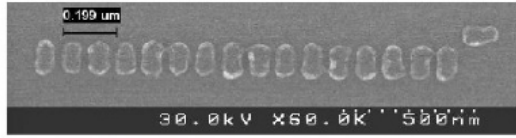

SEM

WIRE

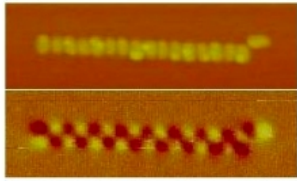

AFM

MFM

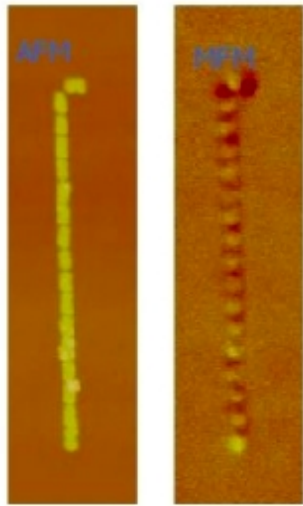

WIRE

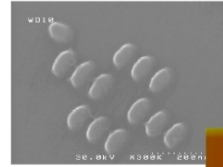

INV

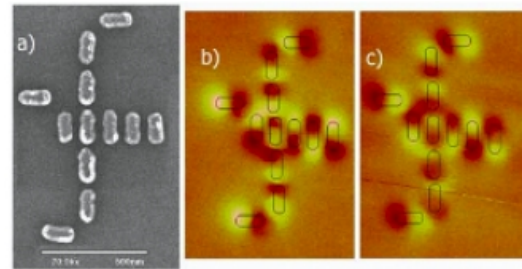
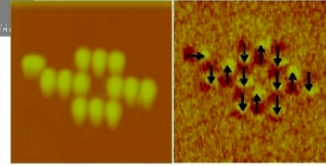

HV

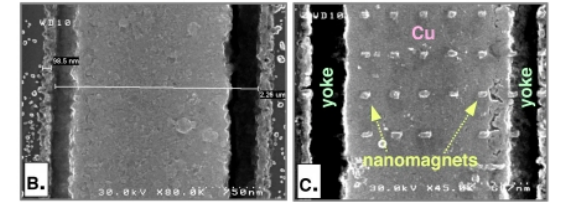
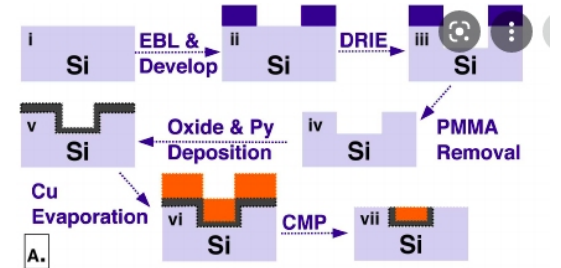

CLOCK

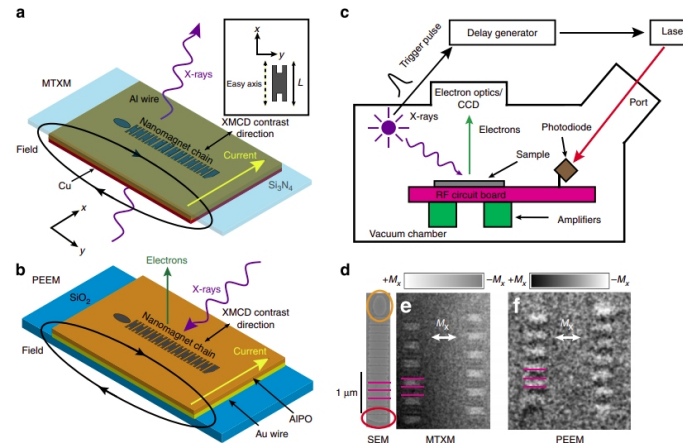
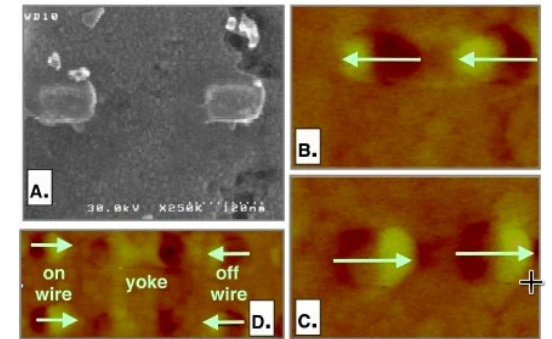

very recent (20)
picosecond switching
observed!

RECENT DEMONSTRATION OF SUBNANOSECOND SIGNAL PROPAGATION IN UCL

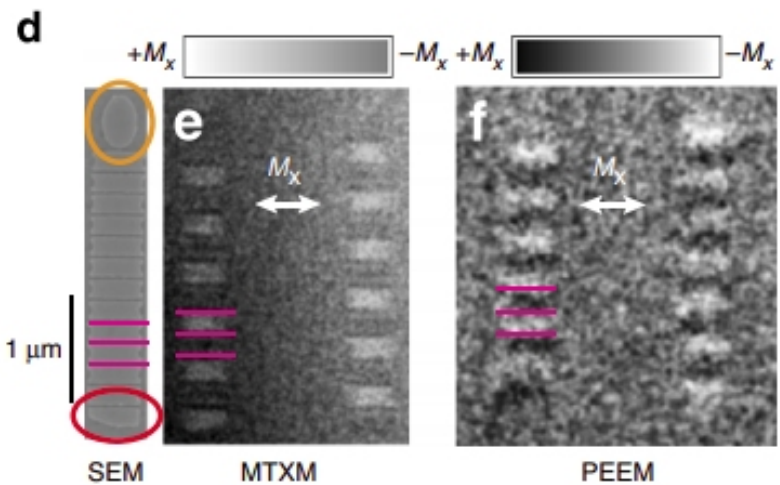
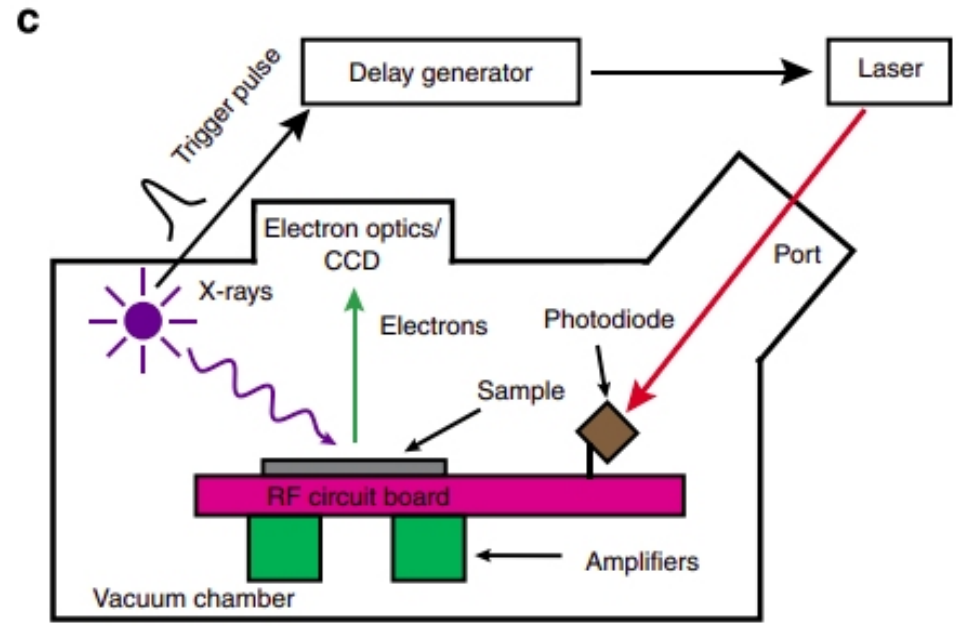
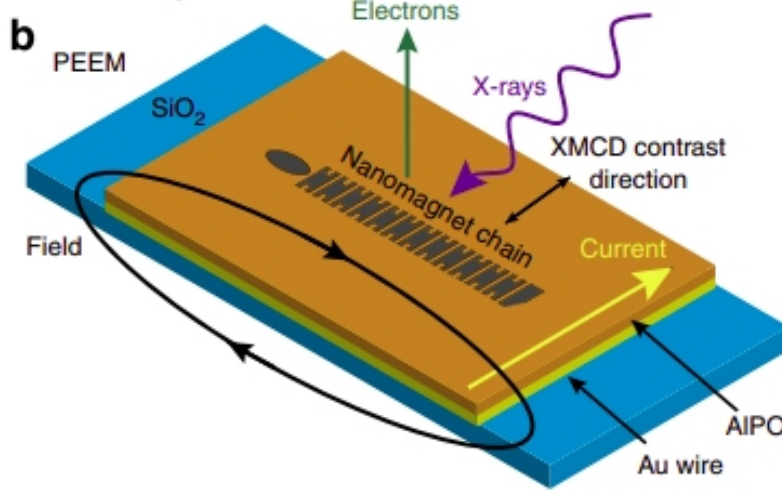
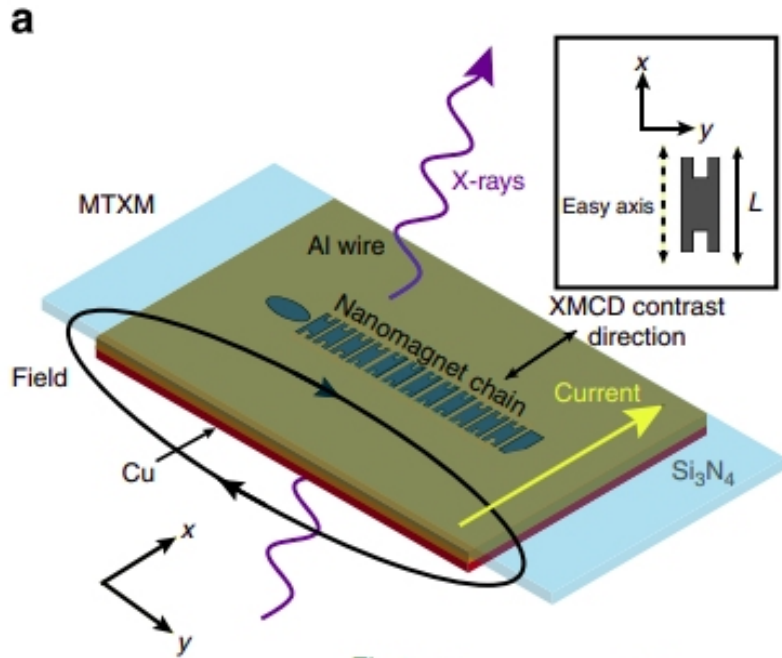

DOI 10.1038/ncomms557466

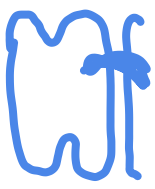

MODIFIED SHAPE

OBSERVED EVOLUTION OF SWITCH PROPAGATION

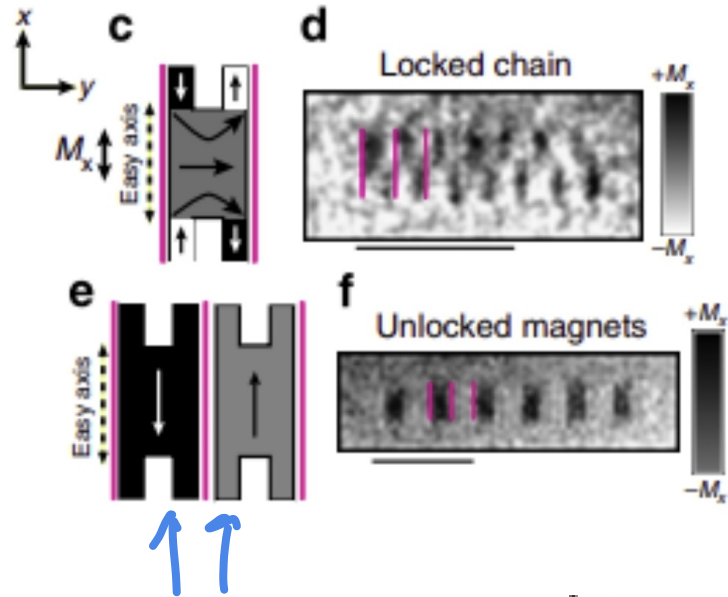

100ps per SWITCH
 ⇒ 5GHz
 2π rad / PHASE
 4 MAG → 2.5 GHz

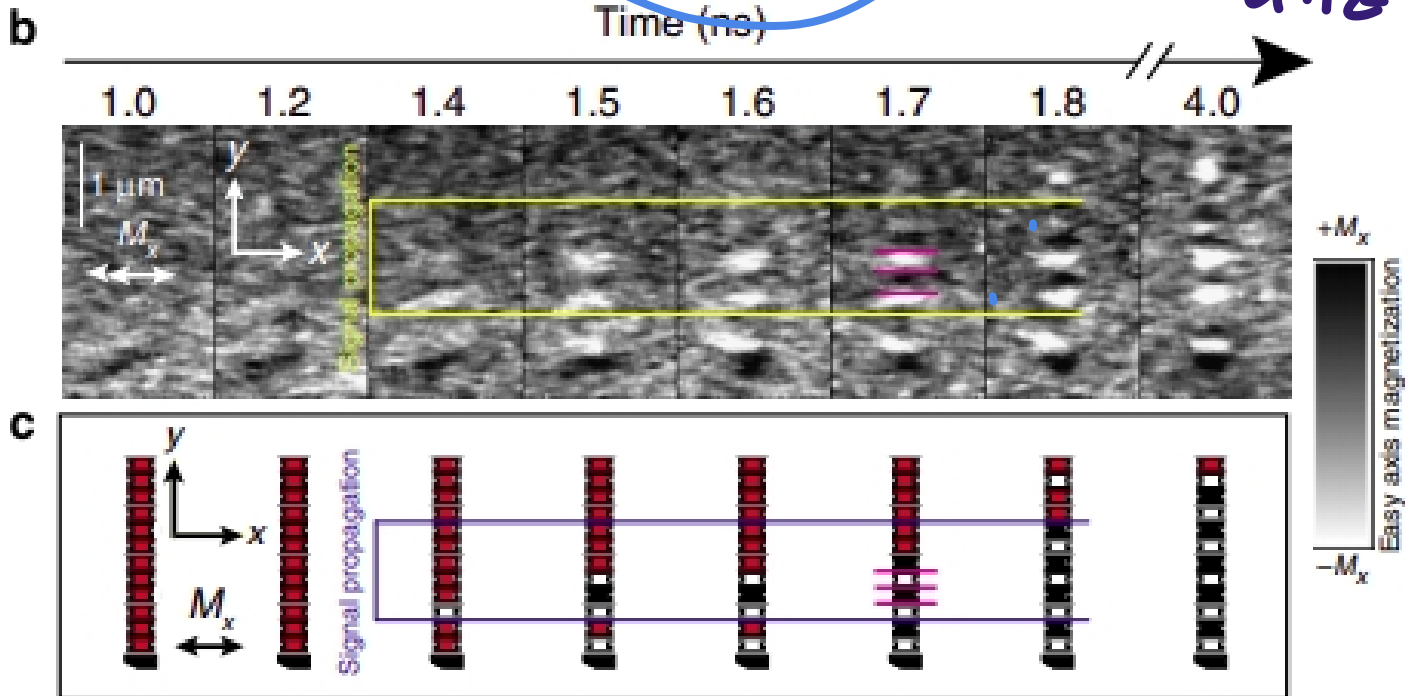
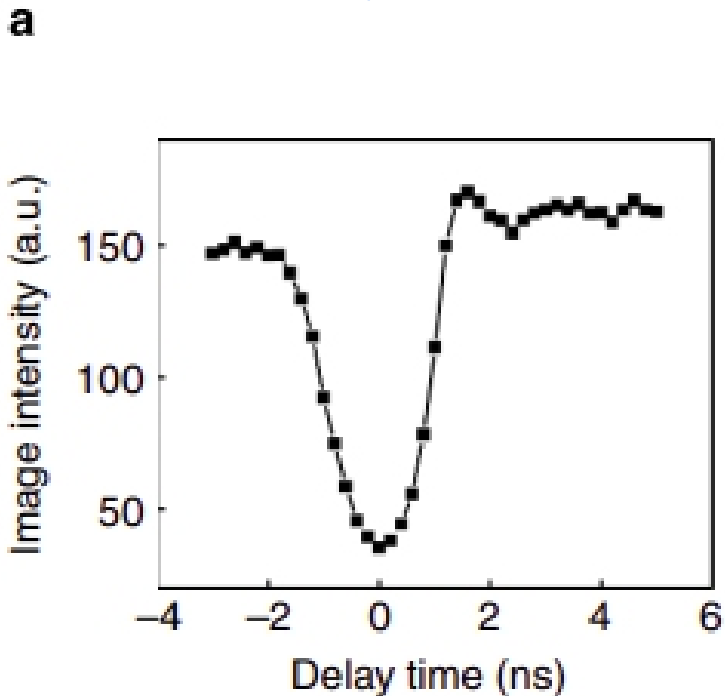

EPFL

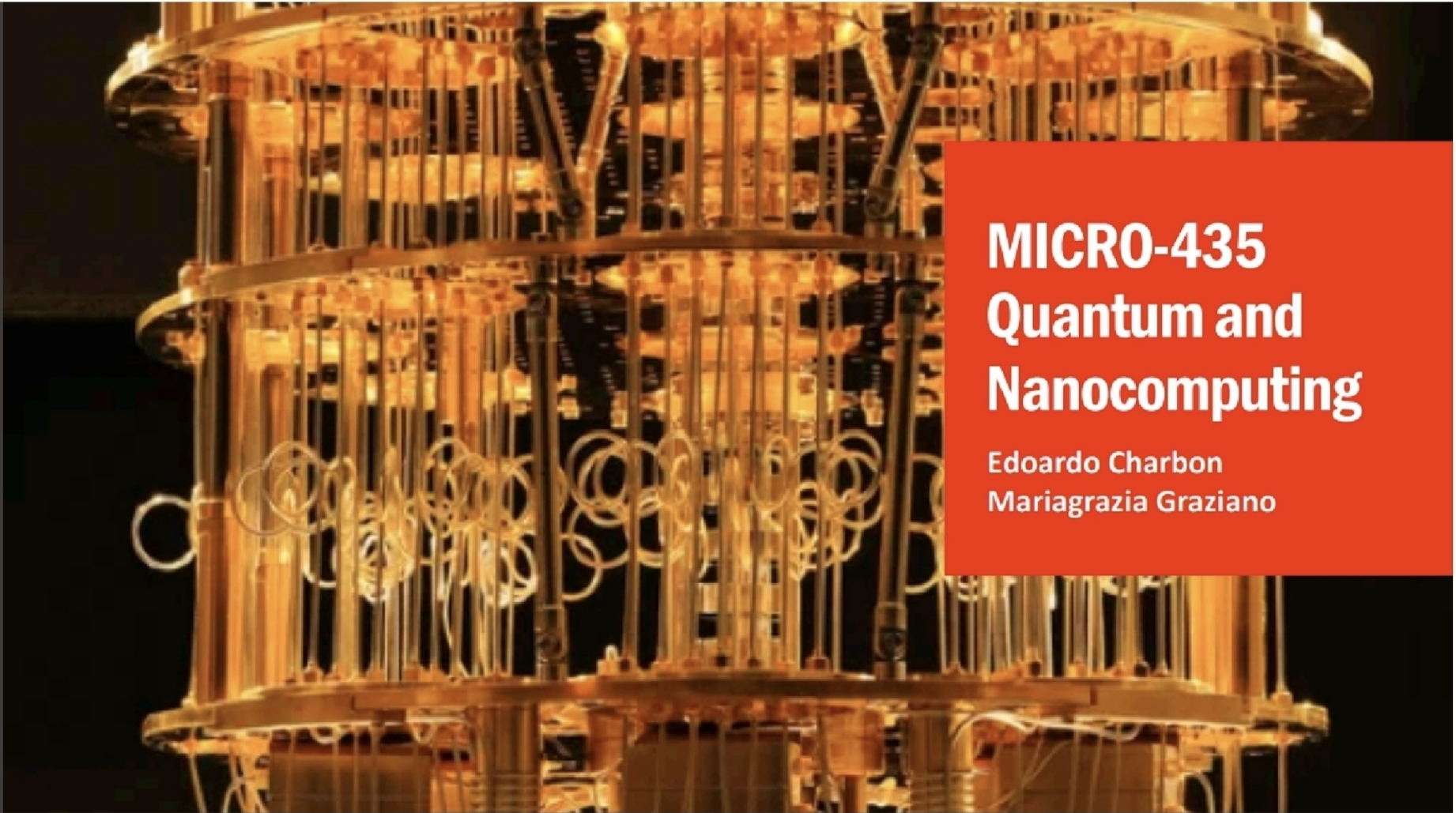

MICRO-435 Quantum and Nanocomputing

Edoardo Charbon
Mariagrazia Graziano

NML - LLG
MICROMAGNETIC SIMULATIONS

NANOMAGNETIC LOGIC

OBJECTIVES

MAGNETIZATION DYNAMICS - LLG

MICROMAGNETIC SIMULATIONS

GENERAL
NANOMAGNETIC
ELEMENTS

```
graph TD; A[GENERAL NANOMAGNETIC ELEMENTS] --> B[MAGNETIZATION DYNAMICS - LLG]; A --> C[MICROMAGNETIC SIMULATIONS];
```

A BIT OF THEORY ON

MAGNETIZATION DYNAMICS

$$\frac{dM}{dt}$$

The goals are

- 1) to understand what happens to a general magnetic element when a magnetic field is applied
- 2) to see how this dynamic is modeled in micromagnetic simulations
- 3) to understand how the model is simplified when nanomagnets are the focus

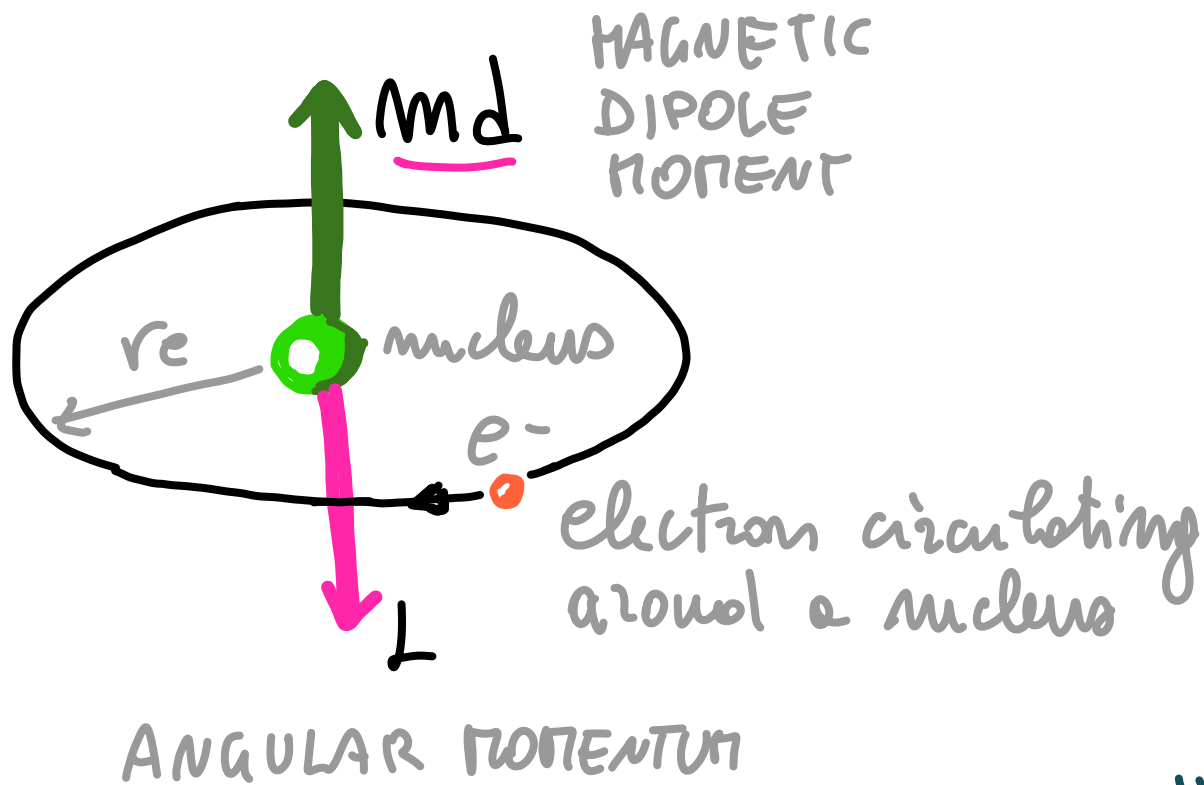

IN A FERROMAGNETIC MATERIAL EVERY ATOM HAS A MAGNETIC DIPOLE MOMENT

USING BOHR MODEL,

WHEN AN ELECTRON e^- CIRCLES AROUND THE NUCLEUS

GENERATES A CIRCULAR CURRENT I_e

THE CURRENT I_e EMBRACING AREA A RESULTS IN A DIPOLE MOMENT AMPLITUDE

$$M_d = I_e \cdot A$$

• If the orbit radius is r_e $A \rightarrow \pi r_e^2$

• If the motion around the nucleus has

ROTATION FREQUENCY ω_0 $I_e \rightarrow -\frac{e\omega_0}{2\pi}$

then
$$m_d = I_e A = -\frac{e\omega_0}{2\pi} \pi r_e^2 = \underbrace{-\frac{e\omega_0}{2} r_e^2}$$

THE NUCLEUS EXERTS A FORCE on the circulating e

that has mass m_e

This generates the ANGULAR MOMENTUM L

having amplitude

$$\underbrace{L = \omega_0 m_e r_e^2}$$

ACCORDING TO BOHR MAGNETON AS:

→ the ENERGY LEVELS of an atom are discrete → the angular momentum is quantized

→ the MAGNETIC dipole is consequently quantized, and ASSUMES VALUES that ARE INTEGER MULTIPLE OF BOHR MAGNETON

$$\mu_B = \frac{2}{2mc} h \quad (\leftarrow \text{Planck's constant})$$

$$m_d = -m_L \cdot \mu_B, \quad m_L = 0, \pm 1, \pm 2, \dots$$

When the Bohr magneton represents the smallest dipole moment of an electron

DIPOLE MOMENT AND ANGULAR MOMENTUM ARE ASSOCIATED BY THE GYROMAGNETIC RATIO γ

$$\vec{m}_d = \gamma \cdot \vec{L}$$

if a single electron

$$\gamma = -\frac{e}{2mc}$$

BUT ELECTRONS HAVE SPIN, THAT
GENERATE A. MAGNETIC MOMENT

→ THE RELATION IS CORRECTED TO

$$\vec{M}_d = g \cdot \gamma \cdot \vec{I} = -g \frac{e}{2m_e} \cdot \vec{I}$$

$g \in$ LANDE CYROMAGNETIC SPLITTING FACTOR
depending on the value

- only orbital momentum
- only spin momentum
- both and other contributions

re considered

IF AN EXTERNAL FIELD H_{eff} IS APPLIED, WITH A CERTAIN

ANGLE α TO m_d \Rightarrow A TORQUE T IS IMPOSED TO
DIPOLE THE MAGNETIC MOMENT

$$\vec{T} = \mu_0 \cdot \vec{m}_d \times \vec{H}_{eff}$$

TORQUE IS PERPENDICULAR TO
 m_d and H_{eff}

THE TORQUE DETERMINES A

PRECESSION MOTION

OF \vec{m}_d AROUND THE DIRECTION OF H_{eff}

(if $\alpha = 0$ there is no precession)

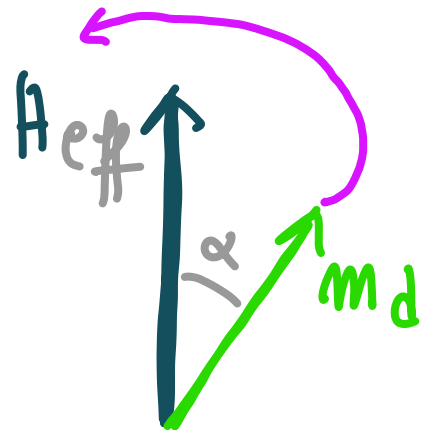

PRECESSION MOVEMENT

TORQUE REPRESENTS THE GRADIENT W.R.T. TIME
OF THE ANGULAR MOMENTUM

$$\vec{T} = \frac{d\vec{L}}{dt}$$

$$\vec{m}_d = \gamma \vec{L} \quad \vec{L} = \frac{\vec{m}_d}{\gamma}$$

substituting
the value of T
given before

$$T = \frac{d}{dt} \left(\frac{\vec{m}_d}{\gamma} \right) = \frac{1}{\gamma} \cdot \frac{d\vec{m}_d}{dt} = \mu_0 \vec{m}_d \times H_{\text{eff}}$$

THEN THE GRADIENT OF m_d W.R.T. TIME IS

$$\frac{d\bar{m}_d}{dt} = \mu_0 \cdot g \gamma \bar{m}_d \times H_{eff} = \mu_0 \cdot g \cdot \frac{e}{2m_e} \cdot m_d \times H_{eff}$$

that is

$$\frac{d\bar{m}_d}{dt} = \gamma_{LLG} \cdot m_d \times H_{eff}$$

DESCRIBES THE NOTION OF AN UNDAMPED MAGNETIC MOMENT IN A FIELD

with $\gamma_{LLG} = \mu_0 g \frac{e}{2m_e} = 2.21 \cdot 10^3 \frac{m}{As}$

IS THE LANDAU-LIFSHITZ CYROMAGNETIC RATIO

IF A MAGNETIC MATERIAL IS CONSIDERED
IN A CERTAIN VOLUME THE RESULTING

MAGNETIC DIPOLE IS THE MAGNETIZATION M

$$\rightarrow \frac{d\bar{M}(\mathbf{r}, t)}{dt} = -\gamma\mu_0 [\bar{M}(\mathbf{r}, t) \times \bar{H}_{\text{eff}}(\mathbf{r}, t)]$$

THIS TERM REPRESENTS THE PRECESSION
MOVEMENT (LANDAU - LIFTSCHITZ eq.) OF MAGNETI-
ZATION VECTOR SUBJECT TO FIELD H_{eff}

IN A REAL MAGNETIC STRUCTURE ALSO DISSIPATION
 MUST BE CONSIDERED (OTHERWISE \vec{M} WOULD NEVER
 STOP PRECESSING AROUND H !)

\Rightarrow DISSIPATION IS INCLUDED (GILBERT & KELLY)
 WITH A DAMPING TERM

$$\rightarrow \frac{d\vec{M}(r,t)}{dt} \Big|_{\text{DISSIPATION}} = \frac{\alpha}{M_S} \left[\vec{M}(r,t) \times \frac{d\vec{M}(r,t)}{dt} \right]$$

α = GILBERT DAMPING M_S SATURATION MAGNETIZATION

SUMMING THE 2 TERMS GIVES

LANDAU-LIFSHITZ-GILBERT EQ. (LLG)

$$\frac{dM(r,t)}{dt} = \underbrace{-\gamma \mu_0 [M(r,t) \times H_{\text{eff}}(r,t)]}_{} + \leftarrow \text{PRECESSION}$$

DAMPING \rightarrow

$$- \frac{\alpha \gamma \mu_0}{\Gamma_S} \left[M(r,t) \times \underbrace{(M(r,t) \times H_{\text{eff}}(r,t))}_{} \right]$$

AFTER AWHILE THE PRECESSION STOPS AND THE MAGNETIZATION TURNS TO THE DIRECTION H_{eff}

DISSIPATION DESCRIBES ENERGY TRANSFER FROM MOTION TO HEAT

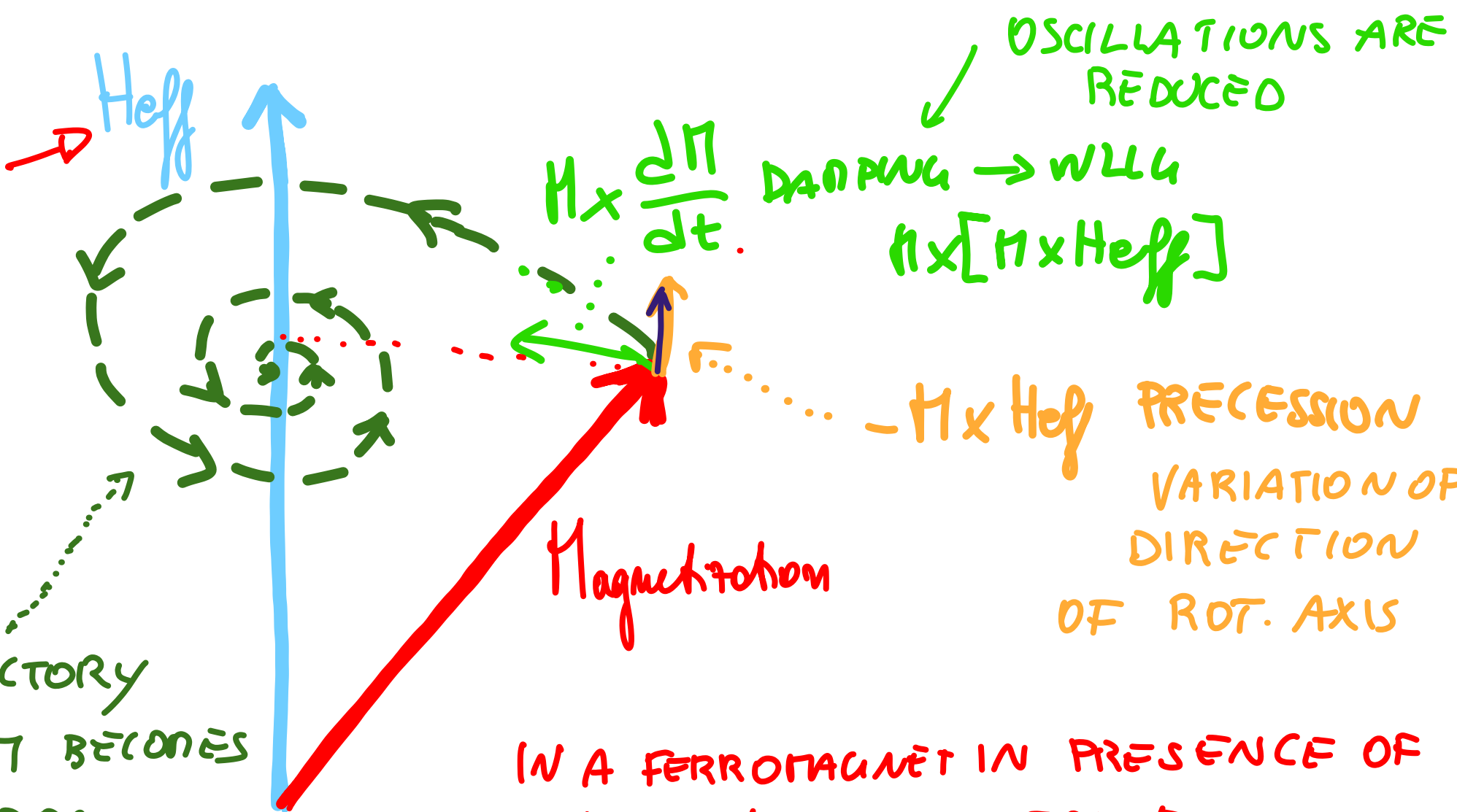

OSCILLATIONS ARE REDUCED

DAMPING \rightarrow WILL
 $M \times [M \times H_{eff}]$

$$M \times \frac{dM}{dt}$$

$-M \times H_{eff}$ PRECESSION
 VARIATION OF
 DIRECTION
 OF ROT. AXIS

Magnetization

TRAJECTORY
 OF M BECOMES
 A SPIRAL
 FORCED BY
 H_{eff} .

IN A FERROMAGNET IN PRESENCE OF
 A FIELD MAGNETIZATION EVOLVES
 AS A SPIRAL TOWARD H_{eff} .

H_{eff} REPRESENTS IN EACH MOMENT THE
EFFECTIVE FIELD (CONSIDERED CONSTANT)
AND INCLUDES SEVERAL COMPONENTS

$$H_{eff} = H_{exc} + H_{anis} + H_{zeem} + H_{DIP} + H_{AOD} + H_{THERM}$$

Depending on the situation some are negligible

H_{ex}: EXCHANGE ENERGY IS RESPONSIBLE OF THE MAGNETIC ORDERING SETTING, INCLUDES
→ QUANTUM EFFECT BETWEEN CONTIGUOUS SPINS THAT ALIGN IN A PARALLEL MAGNETIZATION DIRECTION → LOCAL CONTRIB.,
few tens of nm

H_{anis}: MAGNETO CRYSTALLINE ANISOTROPY, TENDS TO BLOCK ATOM IN A CERTAIN \hat{M} , DUE TO PROPERTY OF MATERIAL

H_{ZEEH} : external MAGNETIC FIELD APPLIED

H_{DEH} : DEMAGNETIZATION DUE TO MAGNETOSTATIC ENERGY (STRAY FIELD ENERGY) DUE TO INTERACTION ALONG THE MAGNETIC FLUXES AROUND; CALLED DEMAGN. BECAUSE IT TENDS TO REDUCE M for MINIMIZING ENERGY; CONTRIBUTE TO SHAPE ANISOTROPY

H_{ADD}: ADDITIONAL TERMS THAT MIGHT BE
PRESENT (e.g. MAGNETOSTRICTION,
SPIN TRANSFER TORQUE...)

H_{THERM} To be considered when $T \neq 0$ AND
• CONSIDER τ , τ_c , and thermal noise

LLG IN MICROMAGNETIC ANALYSIS

LLG ARE USED AS MODEL FOR ALL MAGNETIC SYSTEMS EVOLVING IN TIME UNDER THE INFLUENCE OF A MAGNETIC FIELD

NORMALLY IN MICROMAGNETIC SIMULATIONS THE MULTIDOMAIN LLG VERSION IS APPLIED

MULTIDOMAIN
LLG
MICROMAGNETIC
SIMULATION

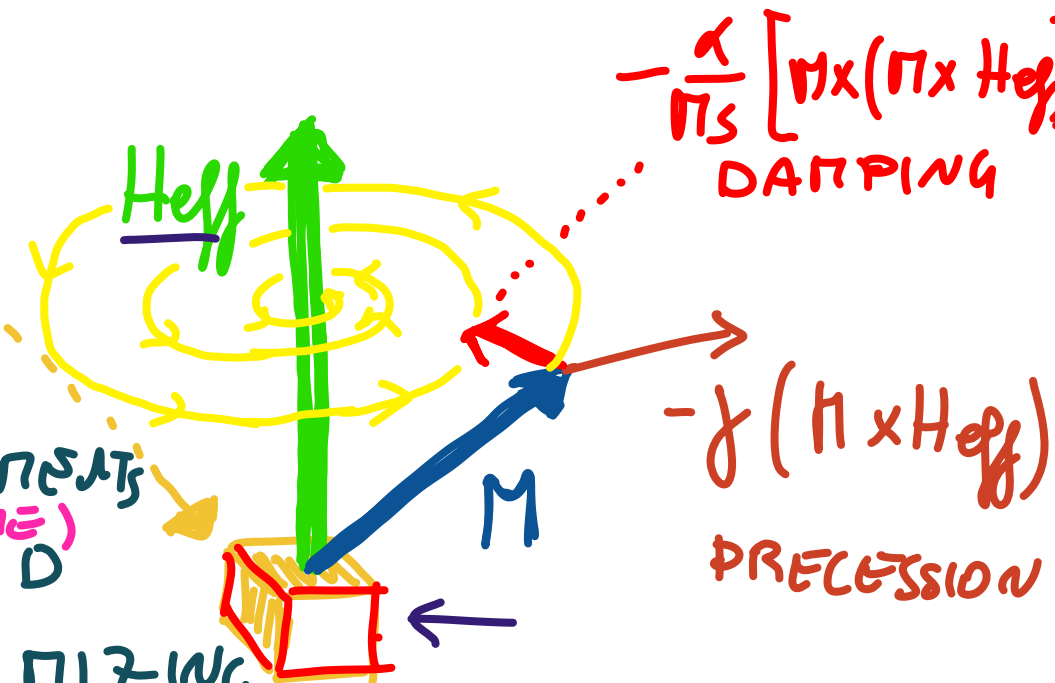
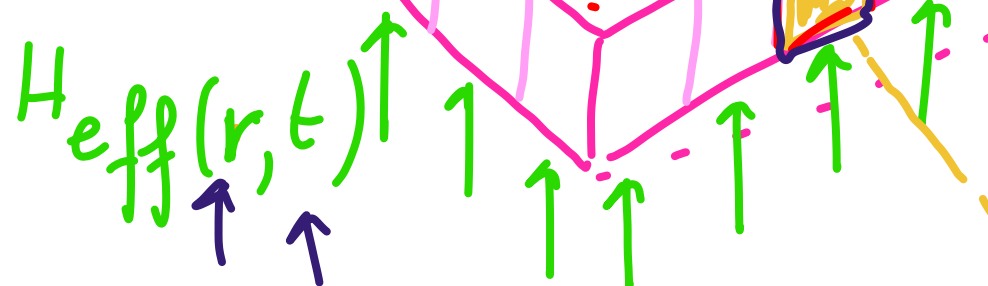
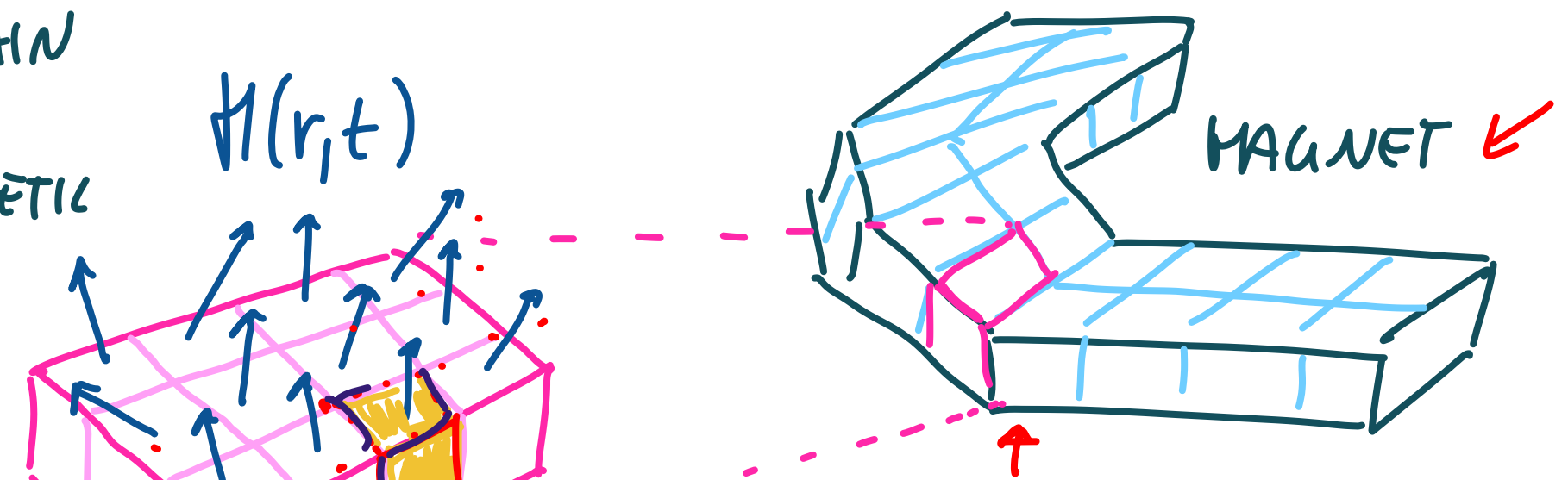

THE MAGNETIC STRUCTURE IS
DISCRETIZED INTO FINITE ELEMENTS
IN A 3D GRID, LLG ARE SOLVED
(IN TIME)

FOR EACH ELEMENT, MINIMIZING

THE TOTAL ENERGY — 3D PARTIAL DIFFERENTIAL EQUATIONS
CONSIDERING ALL THE INTERACTIONS

$$-\frac{\alpha}{M_s} [M \times (\nabla \times H_{eff})]$$

DAMPING

$$-\gamma (M \times H_{eff})$$

PRECESSION

MOST POPULAR SIMULATORS

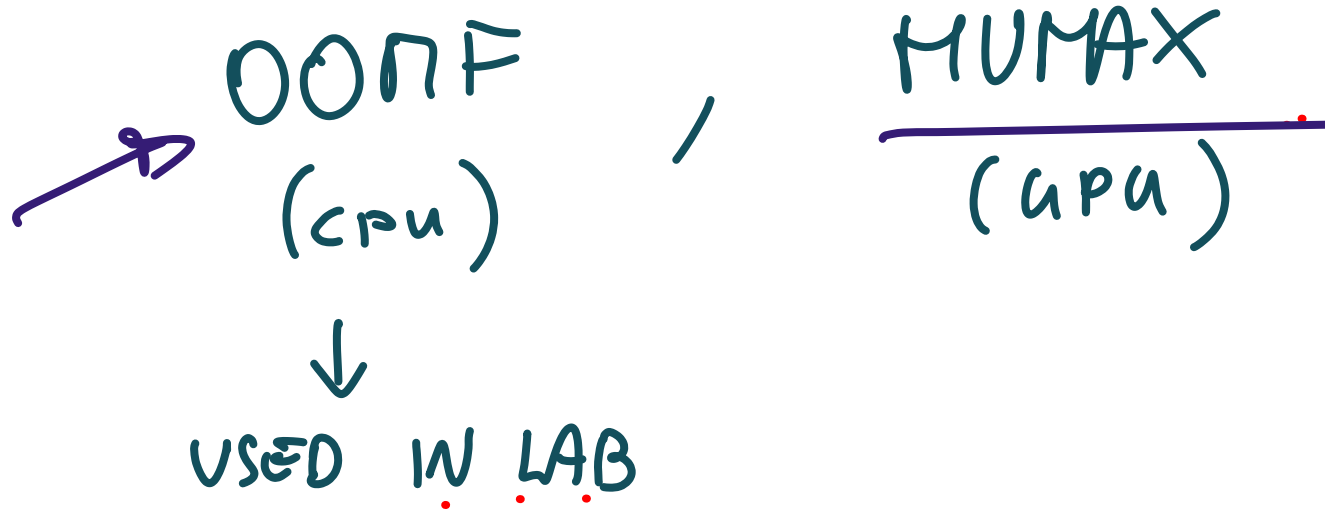

NOTE: THE NANOMAGNET, EVEN IF SINGLE DOMAIN IS SIMULATED USING THE MULTIDOMAIN P. D. D. EQ.

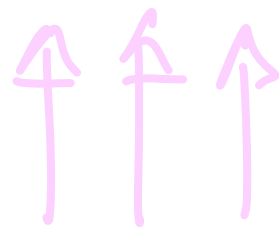

IMPORTANT FOR CORRECTLY READING THE SIM. RESULTS!!

$$\frac{\delta M(r,t)}{\delta \epsilon} = \underbrace{-\gamma \hat{M}(r,t) \times H_{\text{eff}}(r,t)}_{\text{PRECESSION}} - \underbrace{\frac{d\chi}{\pi_s} \left\{ \hat{M}(r,t) \times [H(r,s) \times H_g(r,t)] \right\}}_{\text{DAMPING}}$$

PARTIAL DERIVATIVE DIFFERENTIAL EQ. \uparrow \uparrow
 MAGNETIZATION VECTOR NORMALIZED W.R.T. π_s \leftarrow
 VECTOR \uparrow \leftarrow time \leftarrow VECTOR PRODUCT \uparrow
 \rightarrow x, y, z IN SPACE



LLG MULTI DOMAIN

IF WE WANT TO MODEL THE SINGLE DOMAIN TO MORE RAPIDLY CALCULATE THE INFLUENCE BETWEEN SINGLE NANOMAGNET \rightarrow SINGLE DOMAIN APPROXIMATION \downarrow

SINGLE DOMAIN APPROXIMATION

IN ORDER TO SIMPLIFY

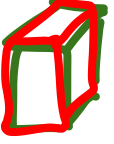
a) 1 DOMAIN ASSOCIATED TO 1 FRESH ELEMENT

b) THE ELEMENT  is approximated with
AN ELLIPSOIDAL ELEMENT  i index of
current ellipsoidal
approximation

c) $H_{eff} \rightarrow H_{eff}^{(i)}(t)$ is simplified to what
is sufficient \downarrow

$$H_{\text{eff}}^{(i)}(t) = \underbrace{H_{\text{Zeem}}^{(i)}}_{\text{EXTERNAL FIELD}} + \underbrace{N^{(i)} \mu_1^{(i)}}_{\text{SELF (DE)MAGNETIZATION}} + \sum_{\substack{j \text{ NEIGHBOURS} \\ j \neq i}} \underbrace{C_{ij}^{(i)} \cdot \mu_1^{(j)}}_{\text{MAGNETOSTATIC ENERGY DUE TO NEIGHBOURS}} \quad H_{\text{dem}}$$

EXTERNAL FIELD

SELF (DE)MAGNETIZATION
 → SELF-INFLUENCE

$N^{(i)}$ MAGNETIC
 DEMAGNETIZATION
 TENSOR

MAGNETOSTATIC
 ENERGY DUE TO
 NEIGHBOURS

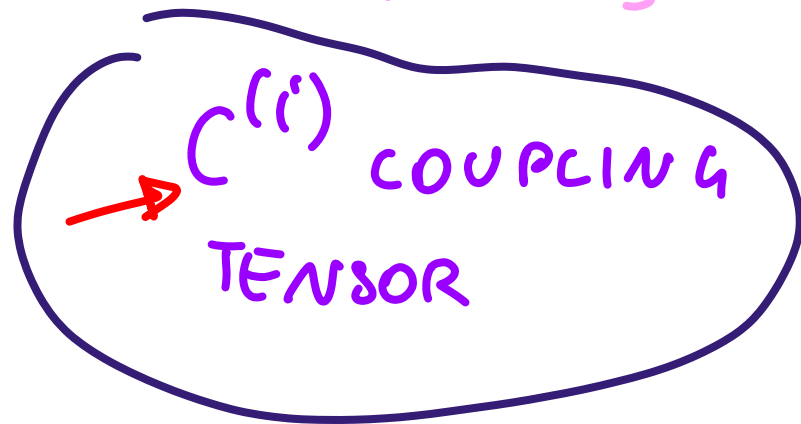
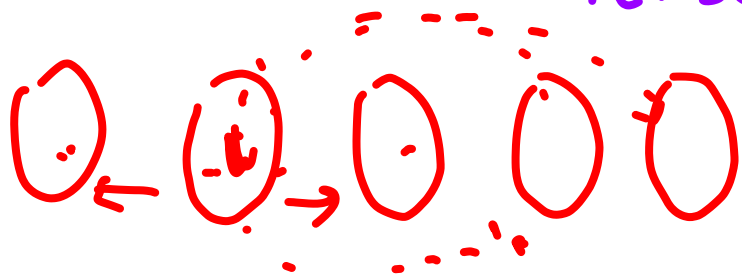

H_{anis} , H_{exec} ARE NORMALLY NEGLECTED IN THIS APPROX.

AS A CONSEQUENCE THE SIMPLIFIED LLG | SINGLE DOMAIN BECOMES

$$\frac{dM^{(i)}(t)}{dt} = \underbrace{-\gamma M^{(i)}(t) \times H_{\text{eff}}^{(i)}(t)}_{\text{precession}} + \underbrace{-\frac{\alpha\gamma}{M_S} \left\{ M^{(i)}(t) \times \left[M^{(i)}(t) \times H_{\text{eff}}^{(i)}(t) \right] \right\}}_{\text{damping}}$$

MAGNETIZATION OF
A SINGLE ELIPSOIDAL
ELEMENT NORMALIZED
W.R.T. M_S

TO SOLVE THE SYSTEM IN TIME EVOLUTION FOR ALL THE SINGLE-MAGNETS

↳ MAGNETIC FCN-LOOP BASED ON SINGLE-DOMAIN LLG eq.

CONSIDERS

→ TIME VECTOR :

$t_k \in \{t_0, t_1, \dots, t_{max}\}$

• CONVERGENCY
using
 ϵ STABILITY

INIT : t_0 , $M_0^{(i)}$ STATUS

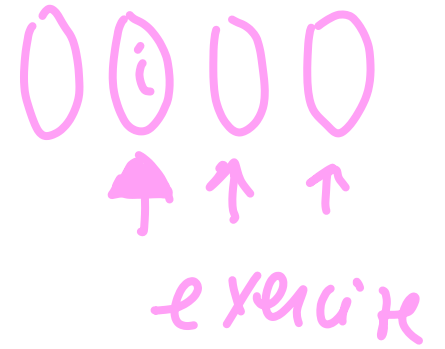

• $\forall t_k \in t_1 \dots t_{max}$

• $\forall i$ element in the system

SOLVE $\frac{dM^i(t)}{dt}$, FIND $M_{t_k}^i$

• USE $M_{t_k}^i$ to FIND $M_{t_{k+1}}^i$ in next time step

UNTIL

→ t_{max} IS REACHED

OR

$$M_{t_{k+1}}^i - M_{t_k}^i < \epsilon_{STABILITY}$$

FOR EVERY i
IN THE SYSTEM

CRISTALLIZATION

- LLG : MAGNETIZATION DYNAMIC
- MULTIDOMAIN LLG
- SINGLE DOMAIN LLG