

Homework #5

You are tasked with sending two control signals for two different qubits using a single channel. In order to do this, you will design a circuit to implement a frequency multiplexing scheme as shown in the following schematic:

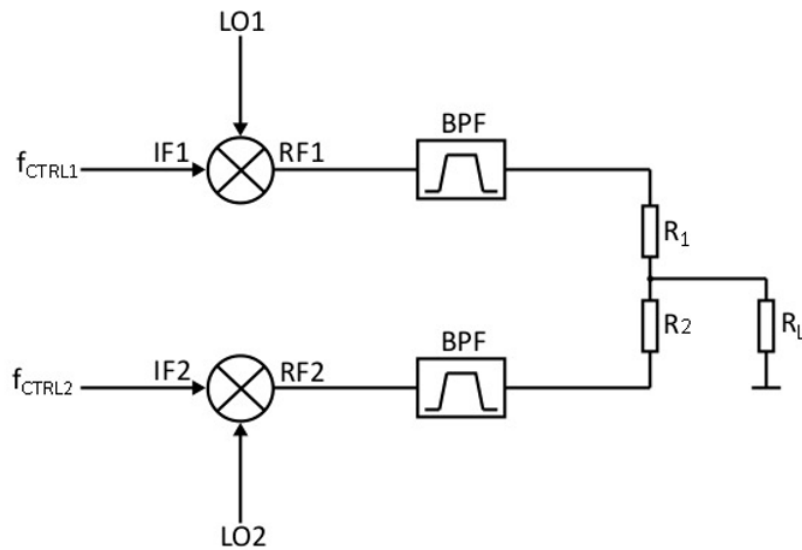

a) (10 points) Model the mixer with the following circuit:

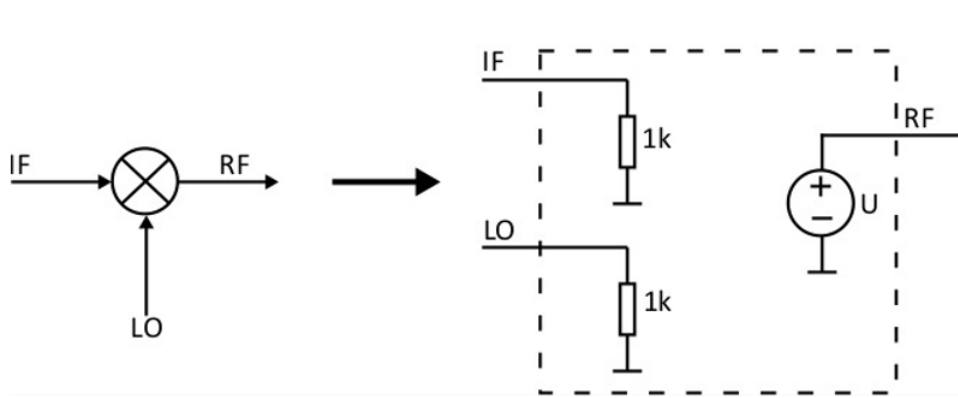

where U is an arbitrary behavioral voltage source (component *bv* in LTspice) with value $V = V(IF) * V(LO)$, where IF and LO are the names (labels) of the two input ports.

b) (15 points) Plot the frequency spectra of the two inputs IF and LO and the output RF of the mixer when IF is a sinusoidal waveform with a DC offset of 0 V, an amplitude of 1 V and frequency 50 kHz and LO is a sinusoidal waveform with a DC offset of 0 V, an amplitude of 1 V and frequency 1 MHz. What does the mixer do? Where are the frequency peaks of RF ?

c) (15 points) Place the two mixers as shown in the first schematic. $LO1$ is a sinusoidal signal with a DC offset of 0 V, an amplitude of 1 V and frequency 1 MHz. $LO2$ is a sinusoidal signal with a DC offset of 0 V, an amplitude of 1 V and frequency 3 MHz. $CTRL1$ is a rectangular signal with

a DC offset of 0 V , an amplitude of 1 V and frequency 50 kHz . $CTRL2$ is a triangular signal with a DC offset of 0 V , an amplitude of 1 V and frequency 50 kHz . Plot the frequency spectra of $RF1$ and $RF2$.

d) (10 points) In order to avoid aliasing, you will need to bandpass filter the two signals before combining them. Assuming you want a 1 MHz bandwidth for each signal, what are the values for f_{C1} , f_{L1} , f_{H1} and f_{C2} , f_{L2} , f_{H2} ?

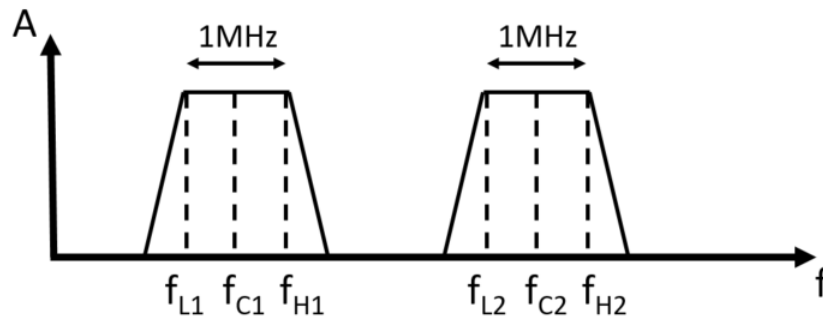

e) (20 points) With the values from d) you can now design the two bandpass filters using an online tool: "<https://rf-tools.com/lc-filter/>". Choose an Elliptic filter type of order 5, with standard component values. Leave the other options as default. Simulate the two filters using the component values indicated by the online tool and plot their transfer functions (Bode plots). What is the advantage of the Elliptic filter compared to the other types?

f) (10 points) Complete the main schematic by adding the filters after

the mixers and using $R_1 = R_2 = 1\text{ k}\Omega$ and $R_L = 1\text{ M}\Omega$. Plot the spectrum of the output signal (voltage across R_L). Does the circuit work?

g) (20 points) You realize you need to send an additional control signal. Modify the schematic and add $CTRL3$, a rectangular signal with a DC offset of 0 V , an amplitude of 1 V and frequency 50 kHz . Fill out the table below and plot the spectrum of the output signal.

Parameter	Value
$LO3$	
f_{C3}	
f_{L3}	
f_{H3}	