

Selected Topics in Advanced Optics

Week 11 – part 1

Olivier J.F. Martin
Nanophotonics and Metrology Laboratory



Metamaterials

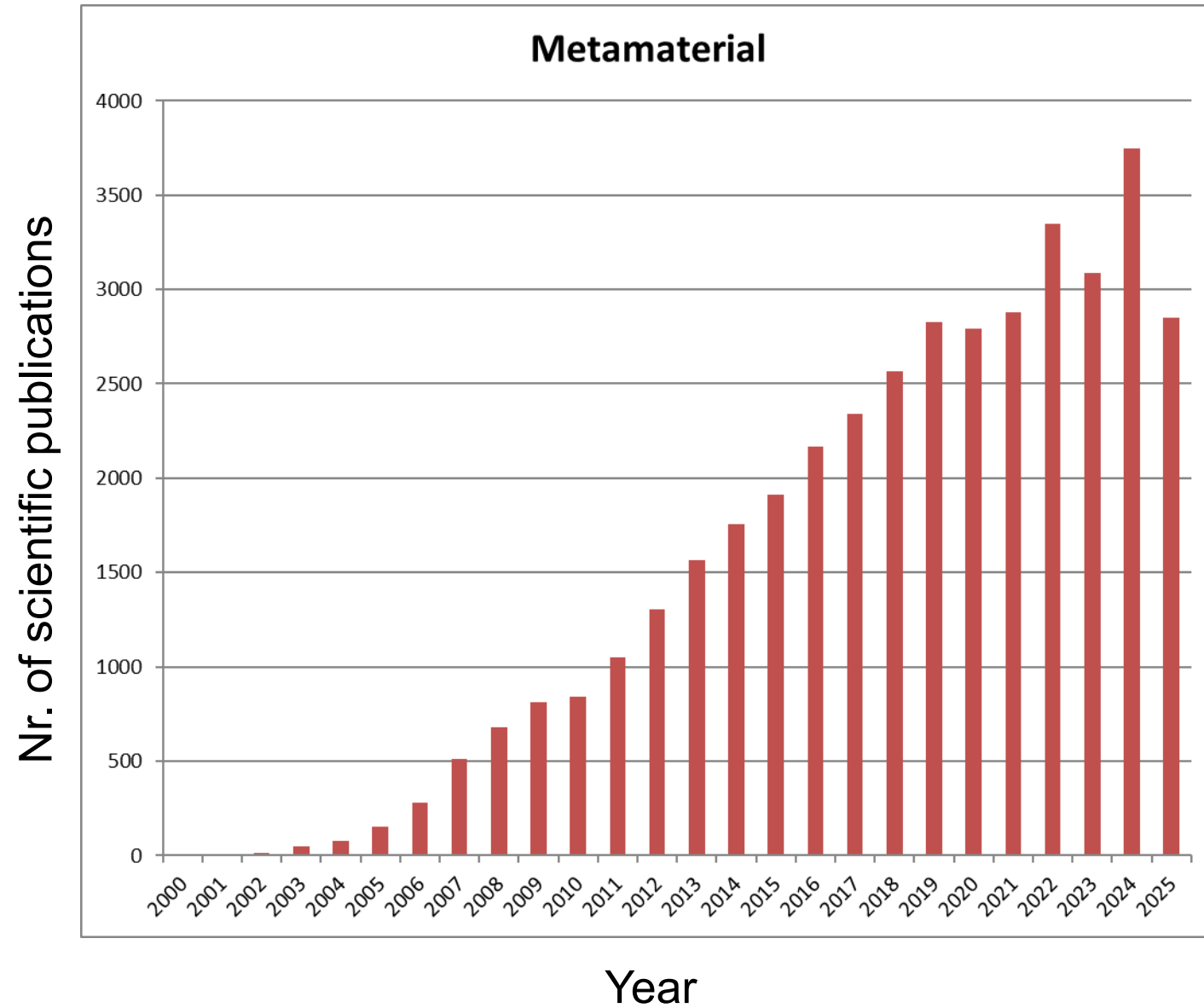

Some references

- W. Cai, and V. Shalaev, Optical Metamaterials: Fundamentals and Applications (Springer, Heidelberg, 2009).
- S.A. Ramakrishna, and T.M. Grzegorczyk, Physics and Applications of Negative refractive Index Materials (SPIE Press, Bellingham, 2009).

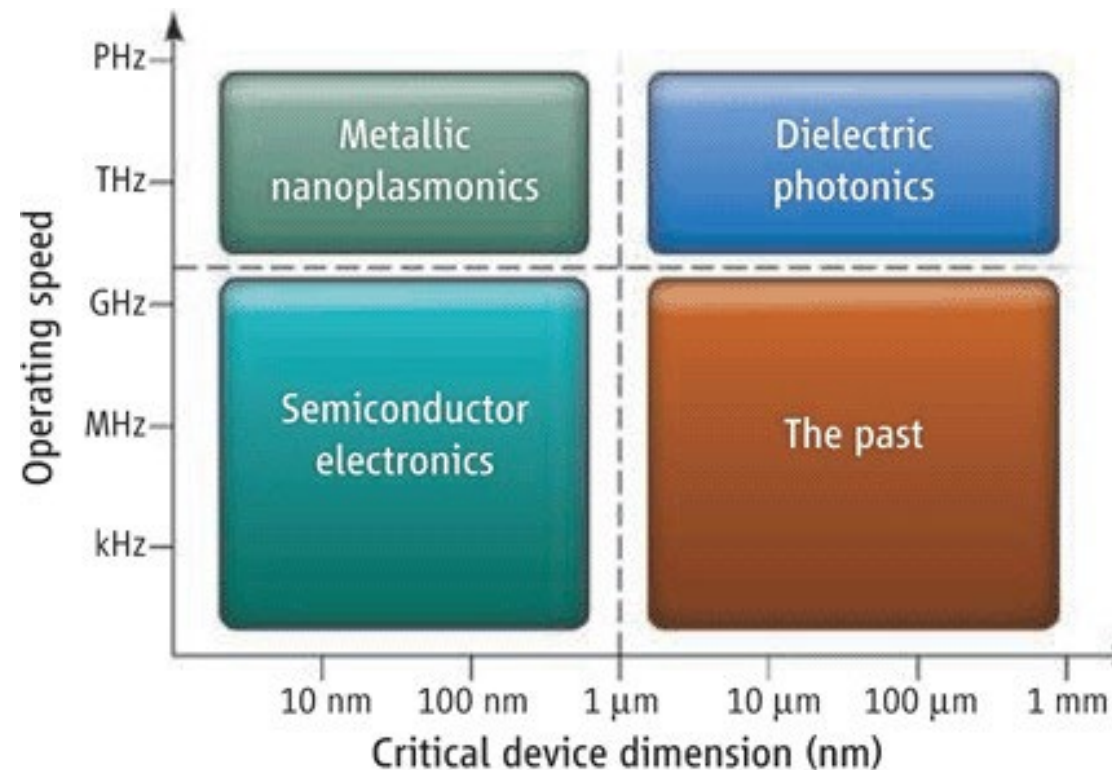

Metamaterials

- When it interacts with electromagnetic radiation, any material behaves in a different way depending on the relationship between the illumination wavelength and the features size:

$$d \gg \lambda$$

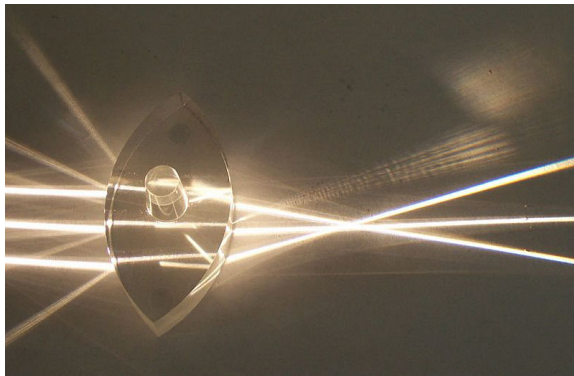

$$\lambda \sim d$$

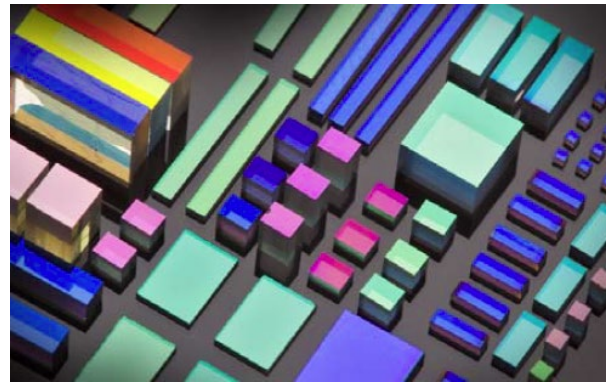

$$\lambda' \sim d$$

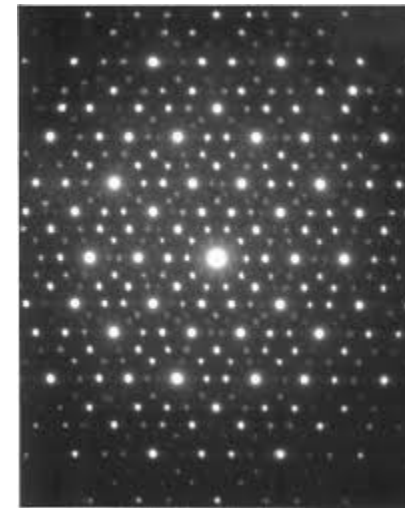

- Only materials where $d \gg \lambda$ can be described in terms of homogeneous ϵ , μ or n , k .

Metamaterials

- A material made from natural atoms/molecules:

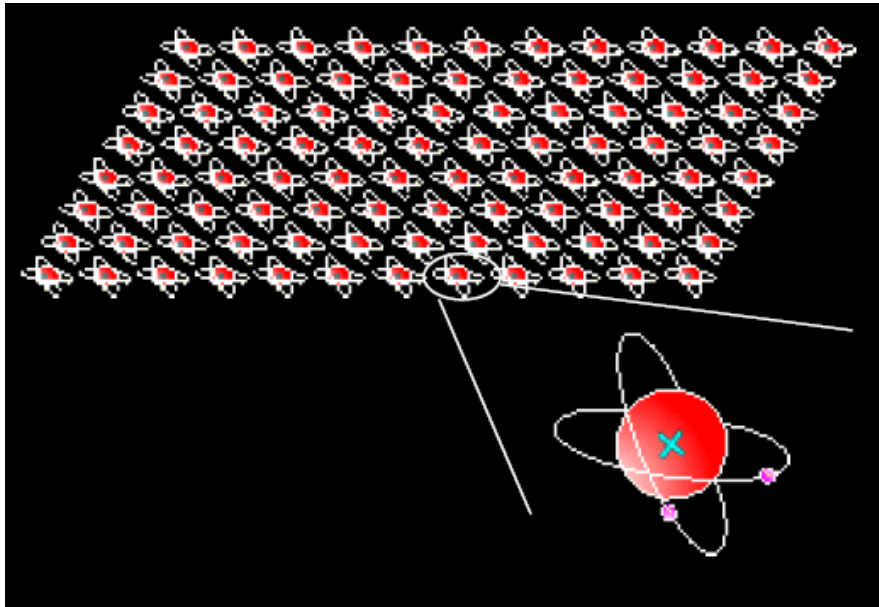

- A metamaterial made from nanostructures or «artificial atoms» (meta-atoms)

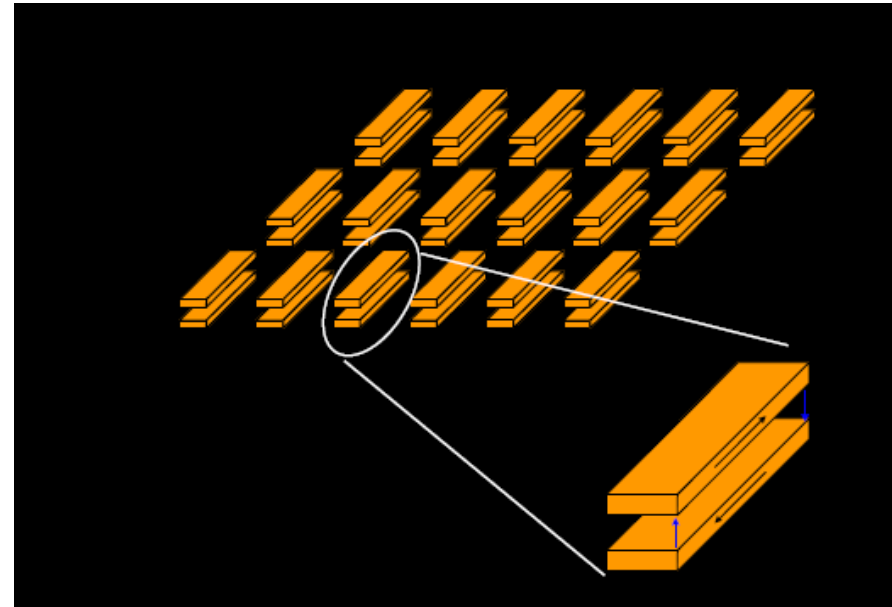

- To behave as a homogeneous material described by macroscopic quantities such as ϵ and μ , the wavelength must be much larger than the dimensions of the «atoms»

Metamaterials vs. Photonic crystals

- Photonic crystals
 - Structures $\sim \lambda$
 - Very precise fabrication
 - Interference-driven

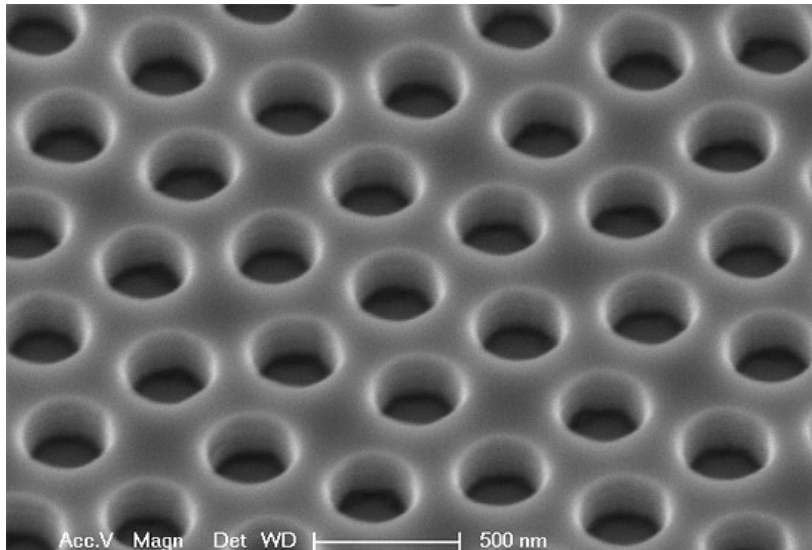

- Metamaterials
 - Structures $\ll \lambda$
 - Fabrication should not matter (homogeneization)
 - Driven by the response of the individual atoms

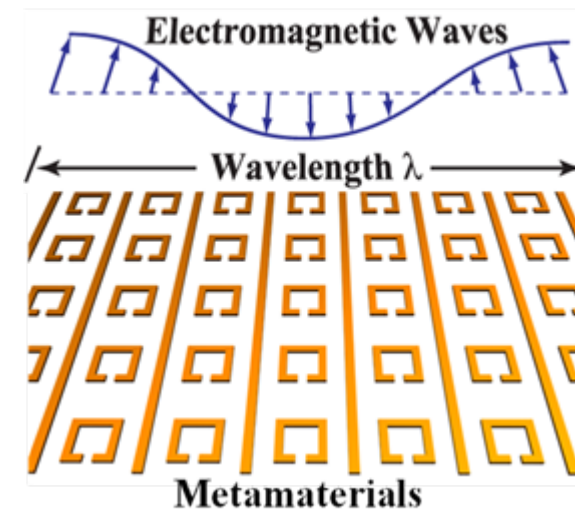

Metamaterials vs. Photonic crystals

- Photonic crystals

- Scaling law:

$$\text{Energy : } u = \frac{a}{\lambda} = \frac{\omega a}{2\pi c}$$

$$\text{Wave vector : } \tilde{k} = \frac{ka}{2\pi}$$

a : period

- As long as materials parameters are the same

- Metamaterials

- No real scaling law

- Operation at the frequency where the «atoms» are resonant

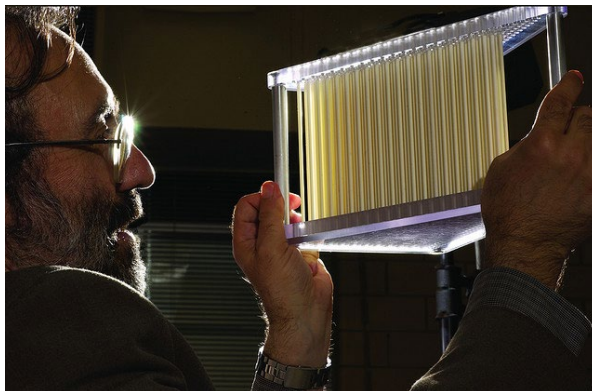

Microwave frequencies

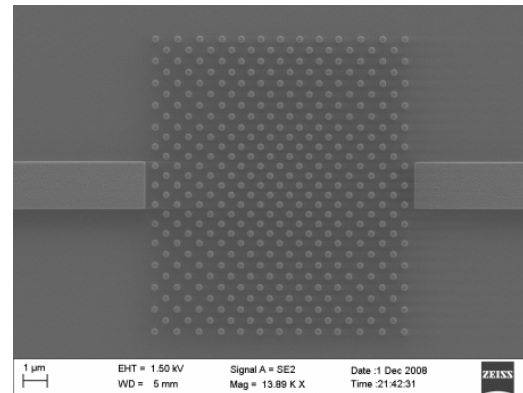

Optical frequencies

Selected Topics in Advanced Optics

Week 11 – part 2

Olivier J.F. Martin
Nanophotonics and Metrology Laboratory

EPFL

Electromagnetic properties and refractive index

SOVIET PHYSICS USPEKHI

VOLUME 10, NUMBER 4

JANUARY-FEBRUARY 1968

338.30

THE ELECTRODYNAMICS OF SUBSTANCES WITH SIMULTANEOUSLY NEGATIVE VALUES OF ϵ AND μ

V. G. VESELAGO

P. N. Lebedev Physics Institute, Academy of Sciences, U.S.S.R.

Usp. Fiz. Nauk 92, 517-526 (July, 1964)

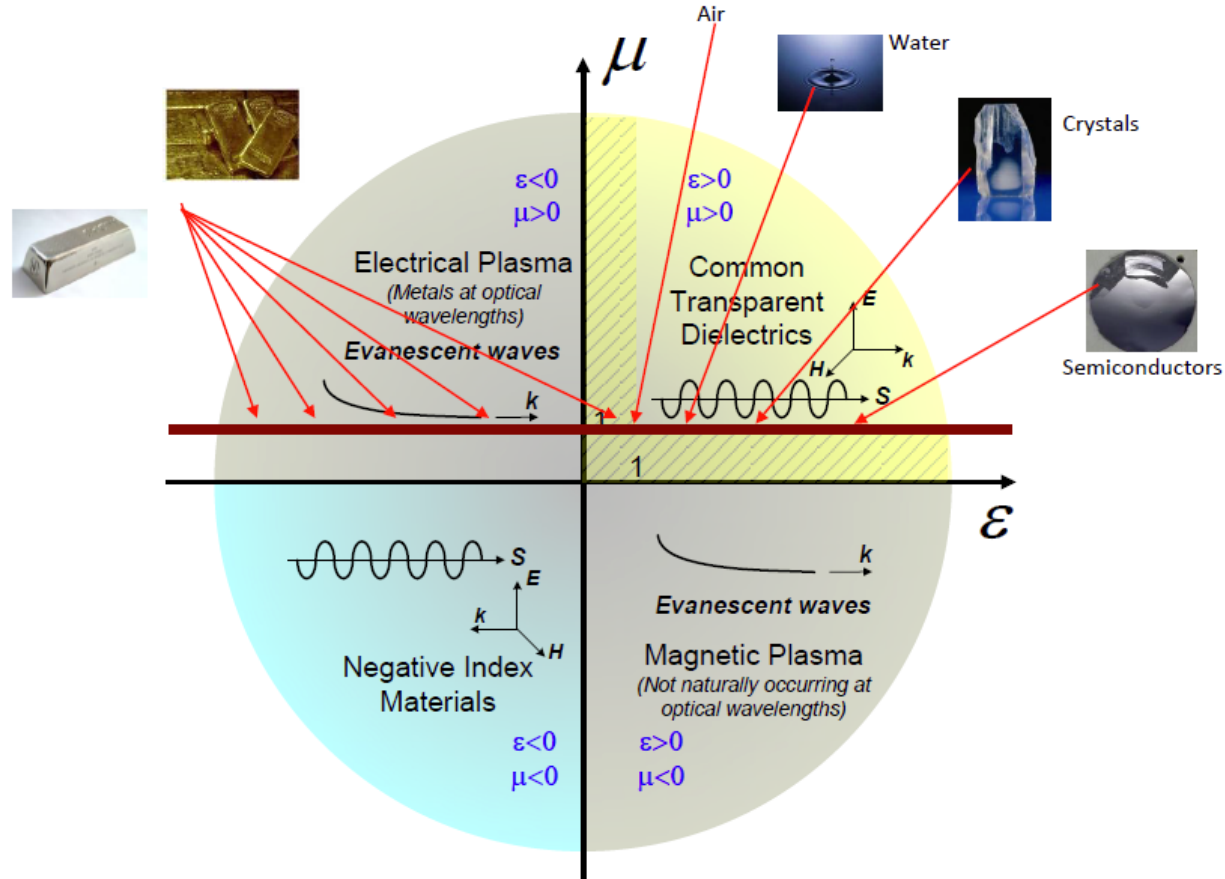

Negative refraction

- Snell law $n_1 \sin(\theta_1) = n_2 \sin(\theta_2)$ is reversed !

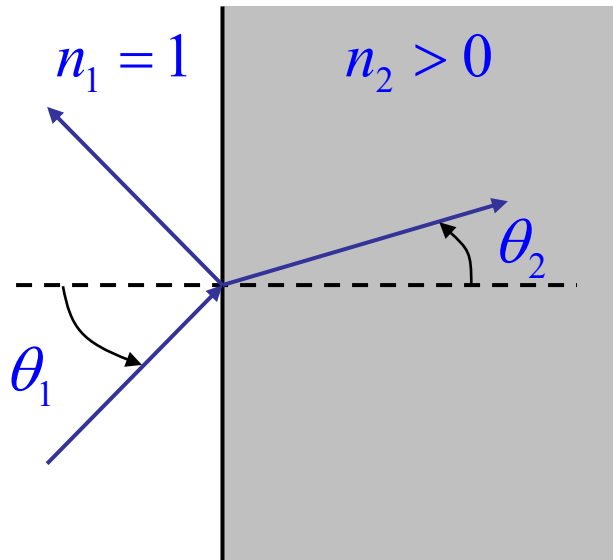

- Negative refraction:

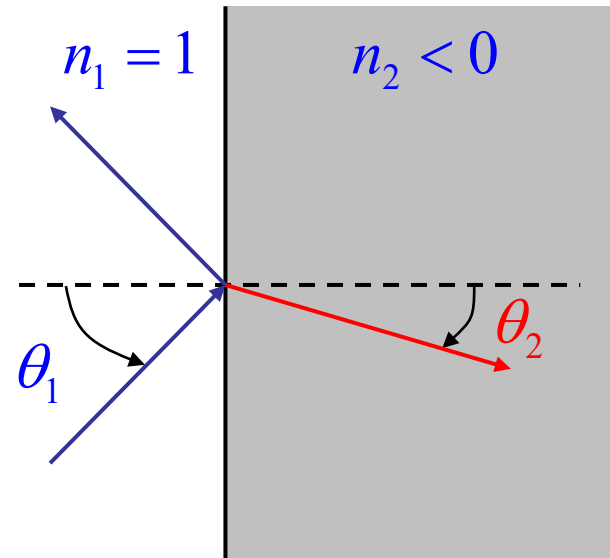

Negative refraction metamaterials

Experimental Verification of a Negative Index of Refraction

R. A. Shelby, D. R. Smith, S. Schultz

We present experimental scattering data at microwave frequencies on a structured metamaterial that exhibits a frequency band where the effective index of refraction (n) is negative. The material consists of a two-dimensional array of repeated unit cells of copper strips and split ring resonators on interlocking strips of standard circuit board material. By measuring the scattering angle of the transmitted beam through a prism fabricated from this material, we determine the effective n , appropriate to Snell's law. These experiments directly confirm the predictions of Maxwell's equations that n is given by the negative square root of $\epsilon \cdot \mu$ for the frequencies where both the permittivity (ϵ) and the permeability (μ) are negative. Configurations of geometrical optical designs are now possible that could not be realized by positive index materials.

www.sciencemag.org SCIENCE VOL 292 6 APRIL 2001



Negative refraction metamaterials

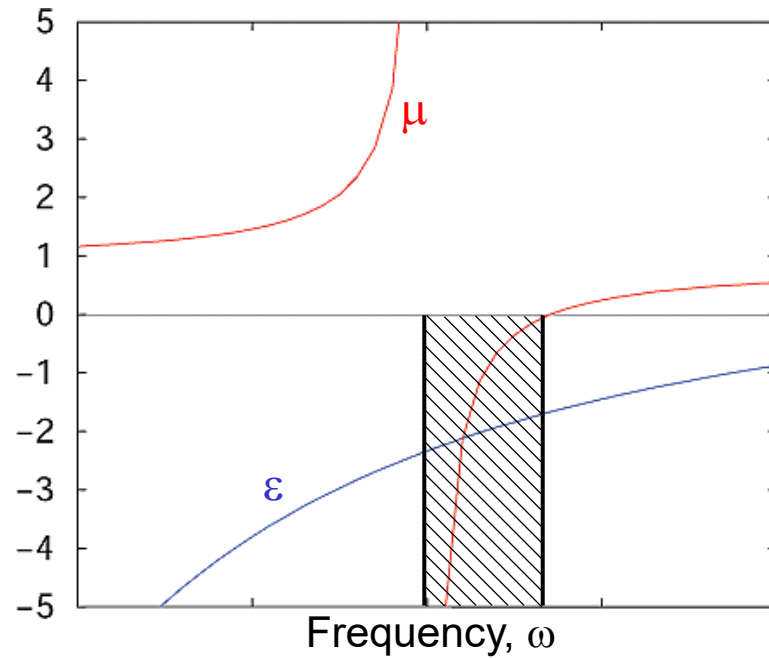

→ ←
 $\epsilon < 0$ and $\mu < 0$ in this range

- The refractive index $n = \sqrt{\epsilon} \sqrt{\mu}$ is negative !

Engineering the magnetic permeability – Split-ring resonator

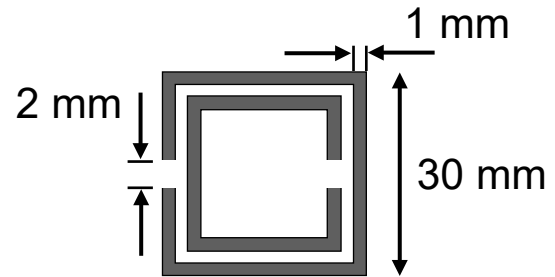

- 5 μm thick Al foil
- Rohacell substrate ($\epsilon=1.07$)

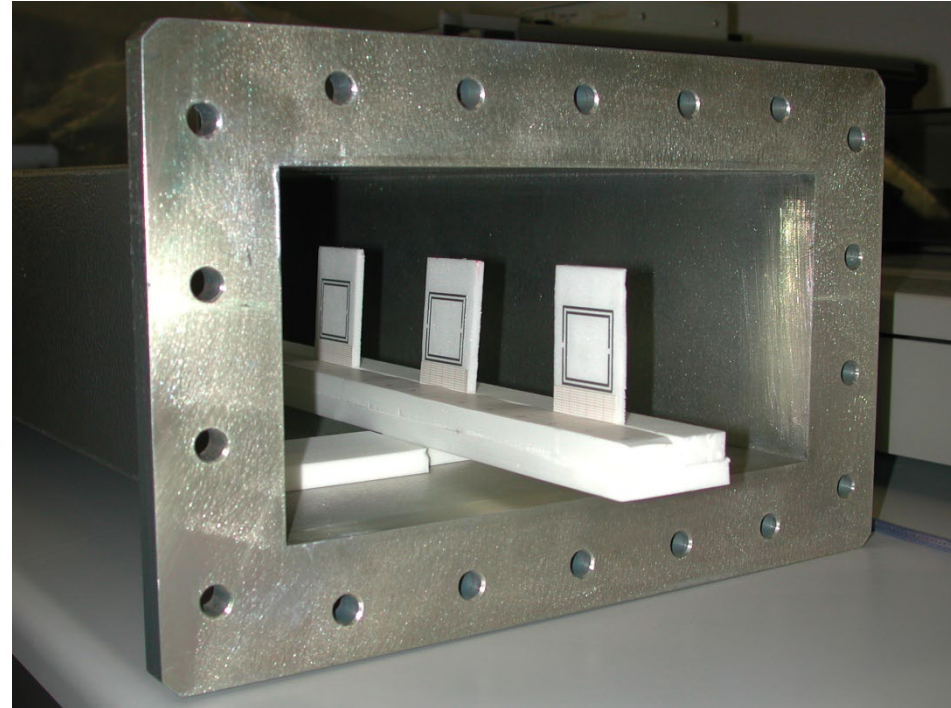

- SRRs in R9 waveguide, TE_{10} excitation:

From an individual structure to a metamaterial

- It is essential that the individual components produce a cooperative effect

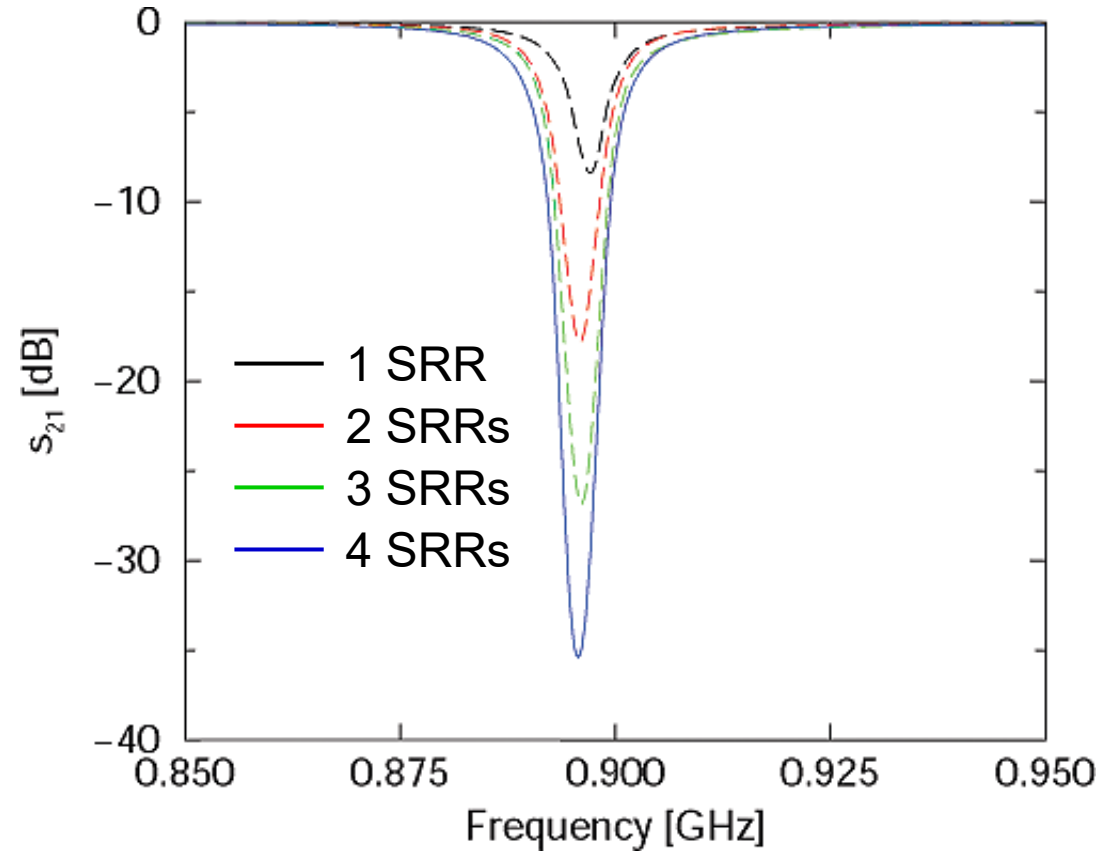
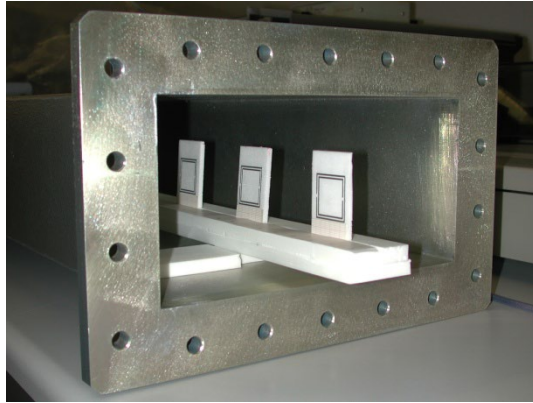

Split-ring resonator

- The magnetic field induces loop currents
- The electric field can also induce such currents through capacitor effects

• Parallel polarization:

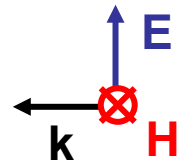
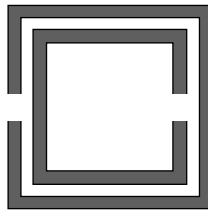

• Perpendicular polarization:

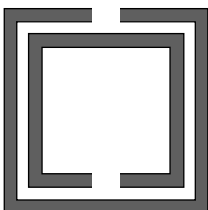
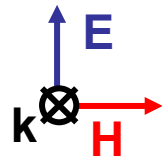
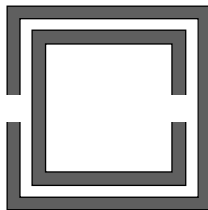

• Measured transmission:

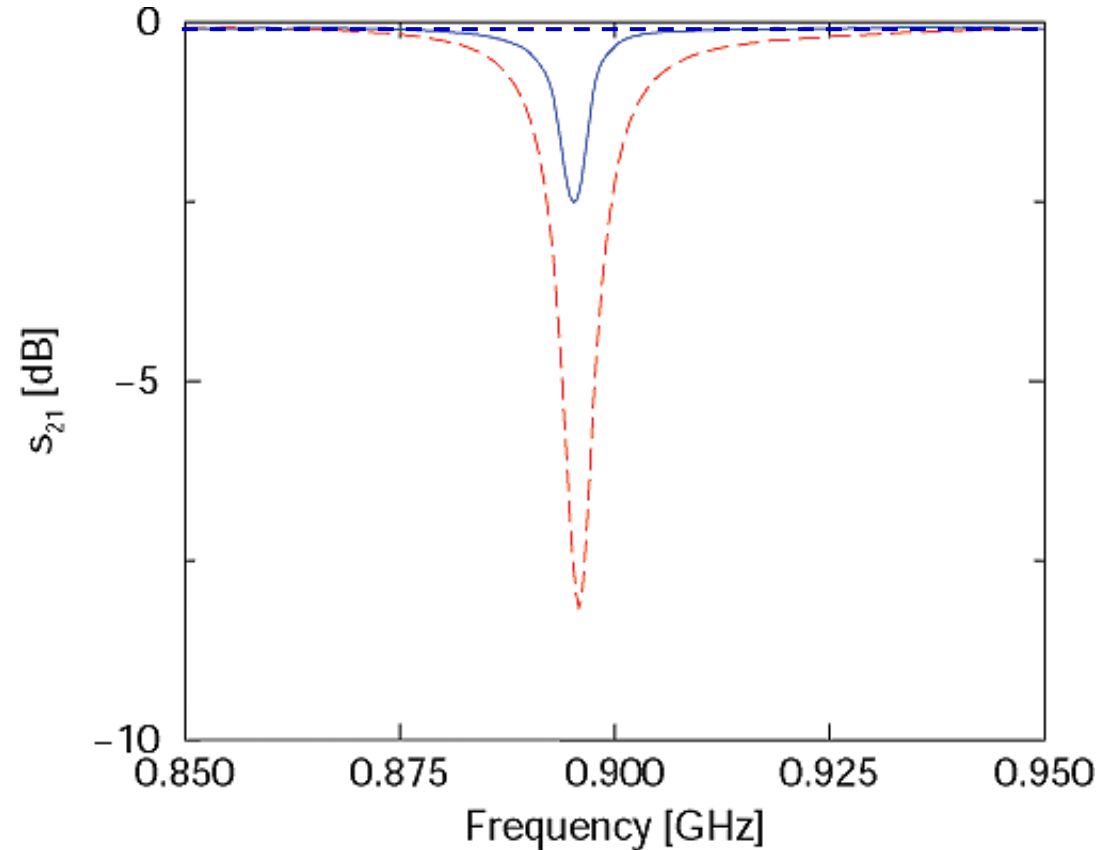

From an individual structure to a metamaterial

- A metamaterial should be isotropic (like a piece of glass)
- This is rarely the case, often the building blocs are anisotropic

• Parallel polarization:

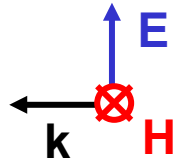
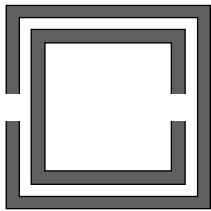

• Perpendicular polarization:

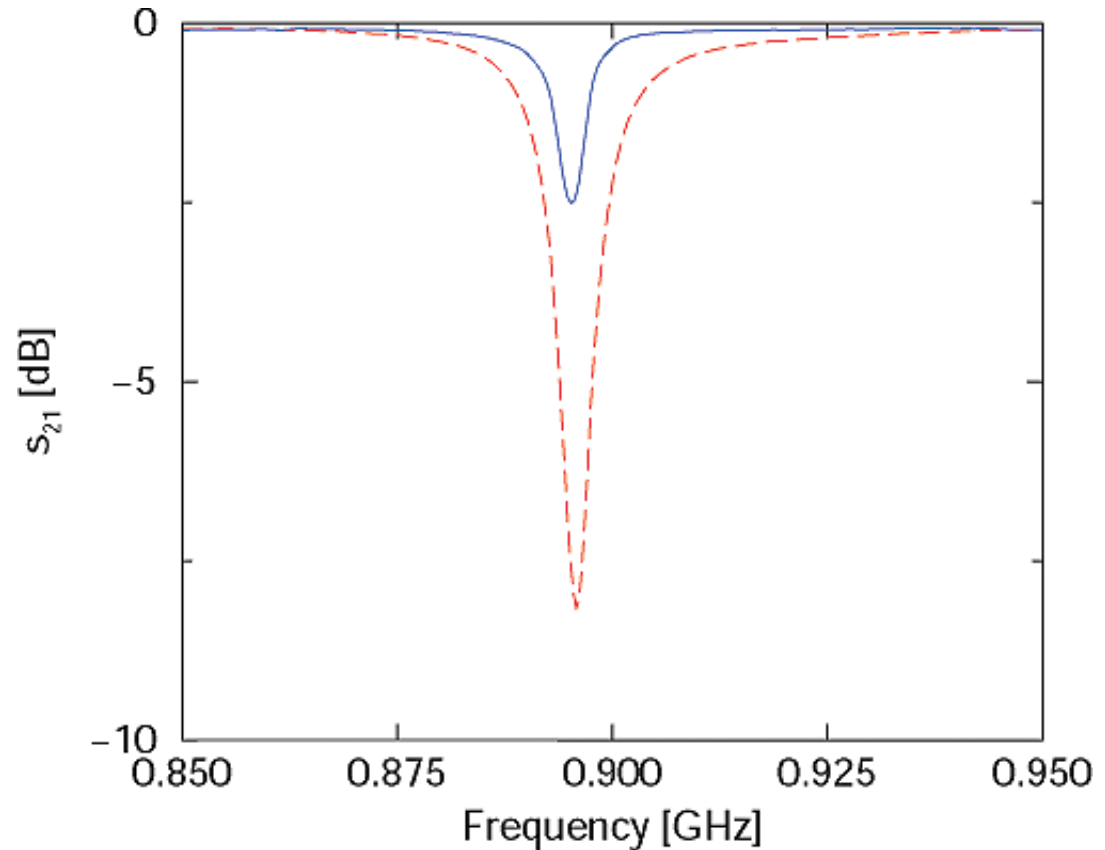
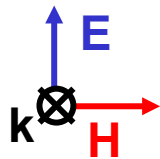
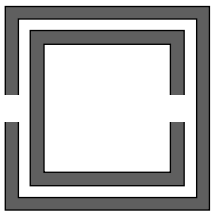

From an individual structure to a metamaterial

- Several attempts have been made to produce isotropic structures

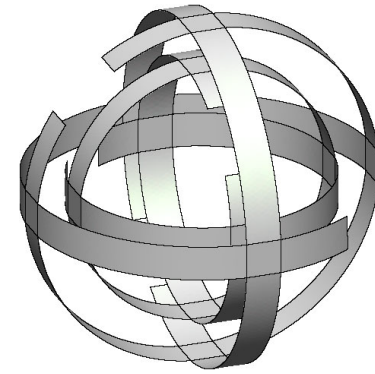
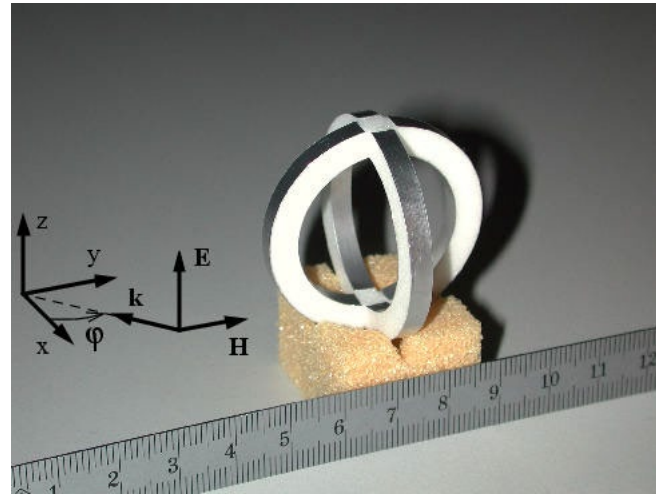

Engineering the negative permittivity – Plasma material

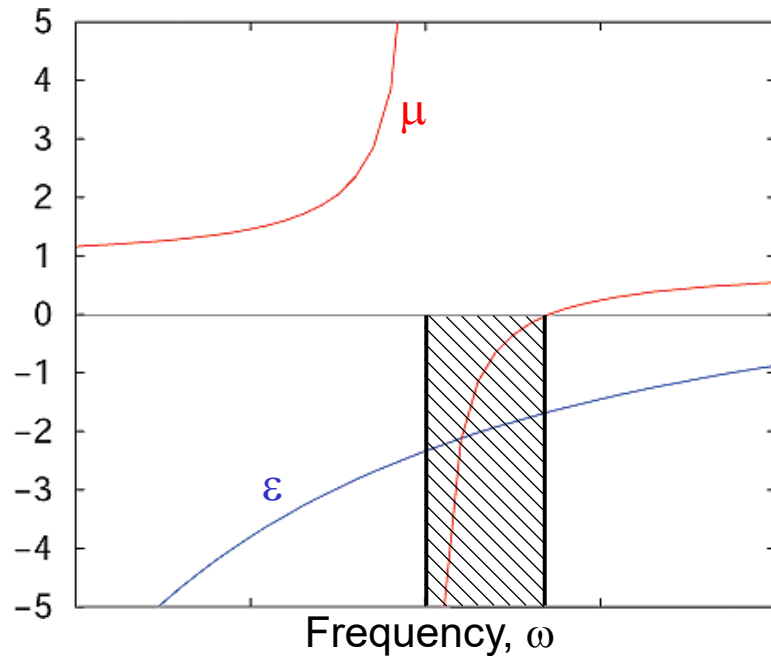

→ ←
 $\epsilon < 0$ and $\mu < 0$ in this range

- The optical index $n = \sqrt{\epsilon} \sqrt{\mu}$ is negative !

Engineering the negative permittivity – Plasma material

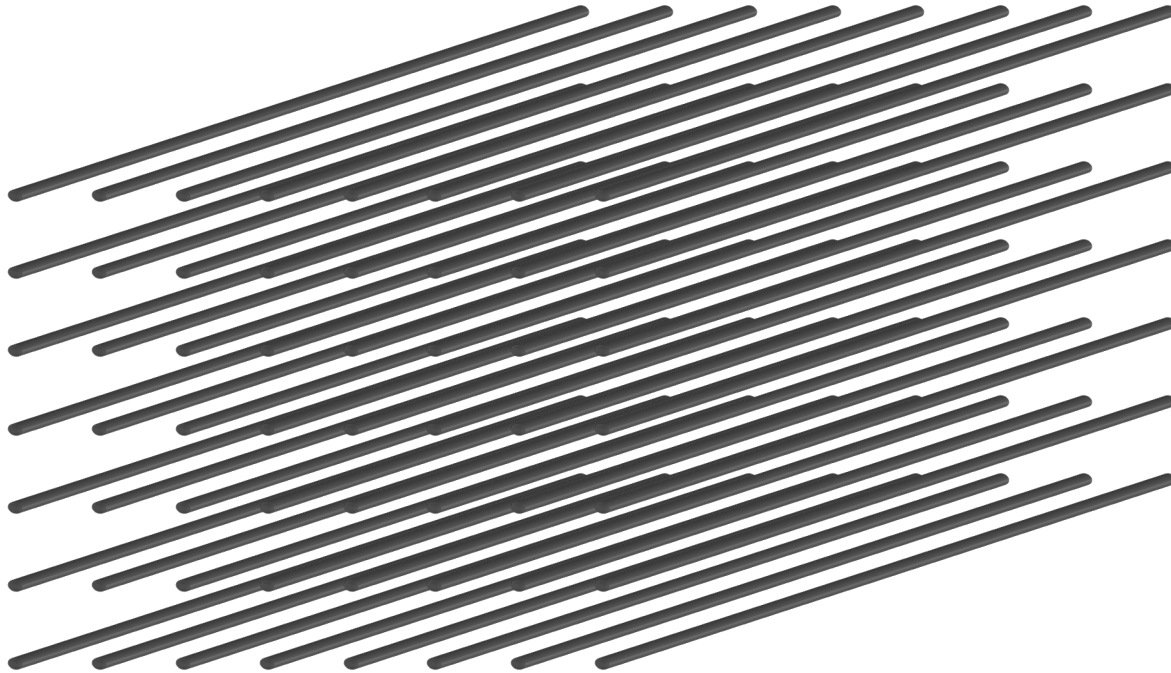

Microwire array

r : radius

a : spacing

$$(f_p^{\text{theo}})^2 = \frac{c^2}{2\pi a^2 \ln(a/r)}$$

J.B. Pendry et al. J. Phys. C vol 10, p. 4785 (1998)

Engineering the negative permittivity – Plasma material

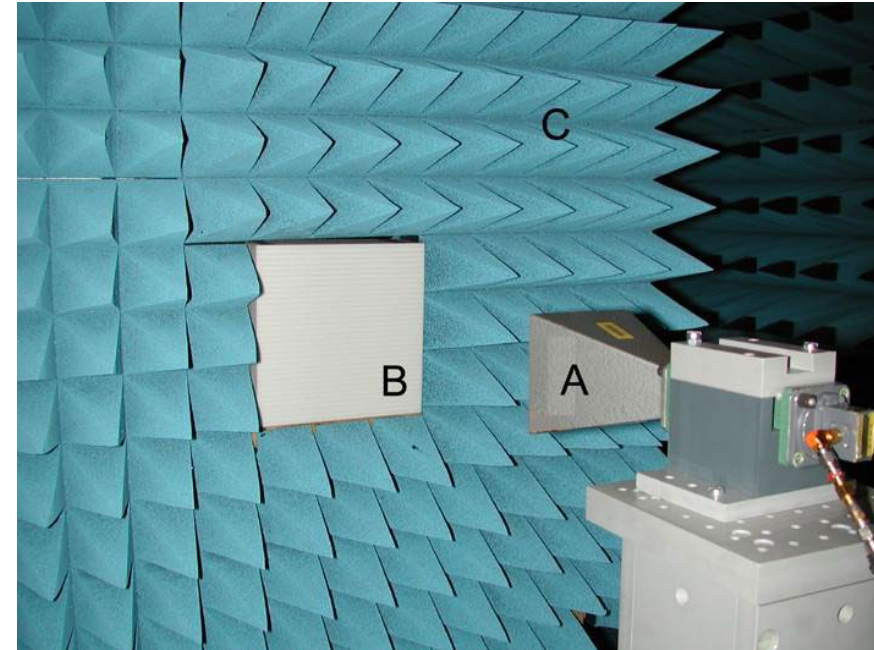
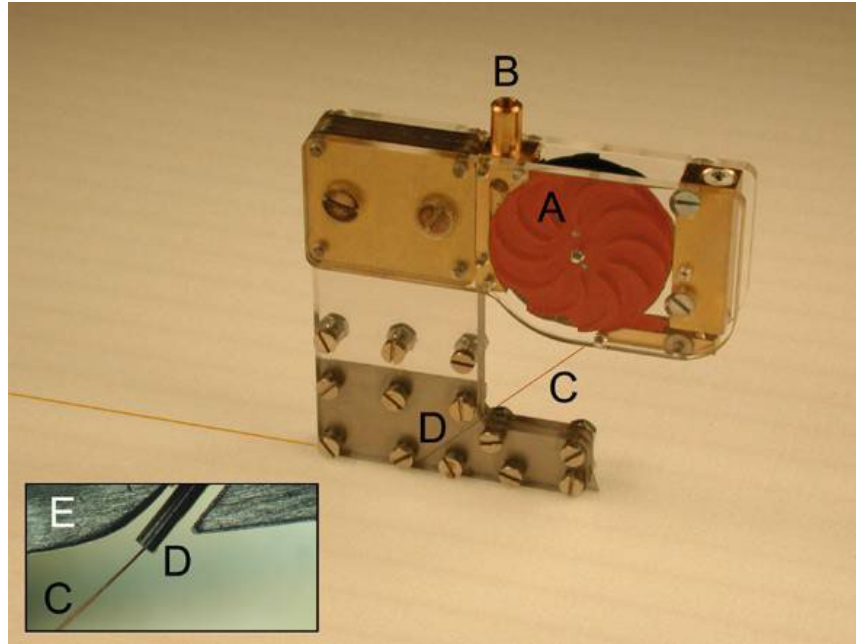

20 x 20 cm² Rohacell plate
 $r=10 - 30 \mu\text{m}$ copper wires

Engineering the negative permittivity – Plasma material

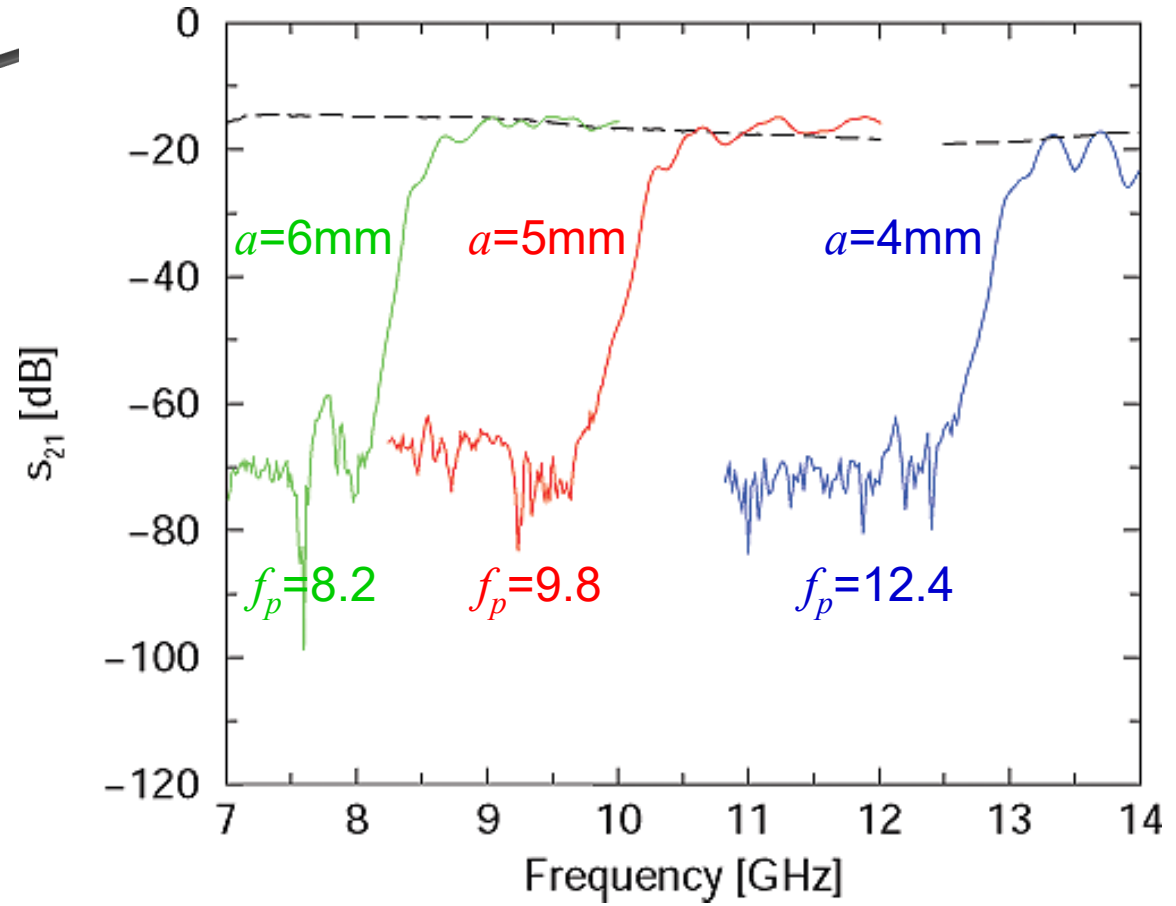
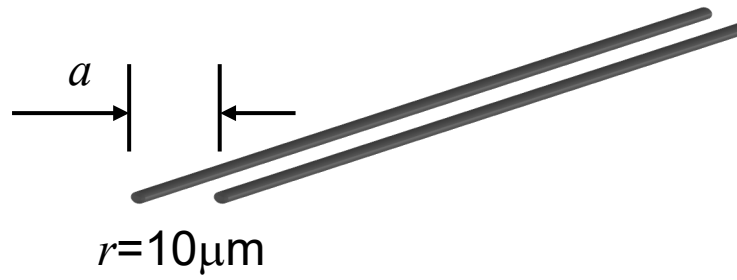

Engineering the negative permittivity – Plasma material

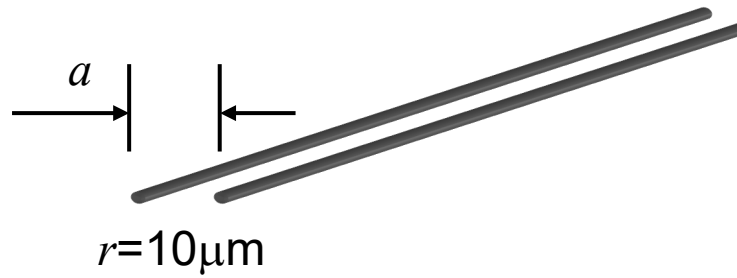

$$(f_p^{\text{theo}})^2 = \frac{c^2}{2\pi a^2 \ln(a/r)}$$

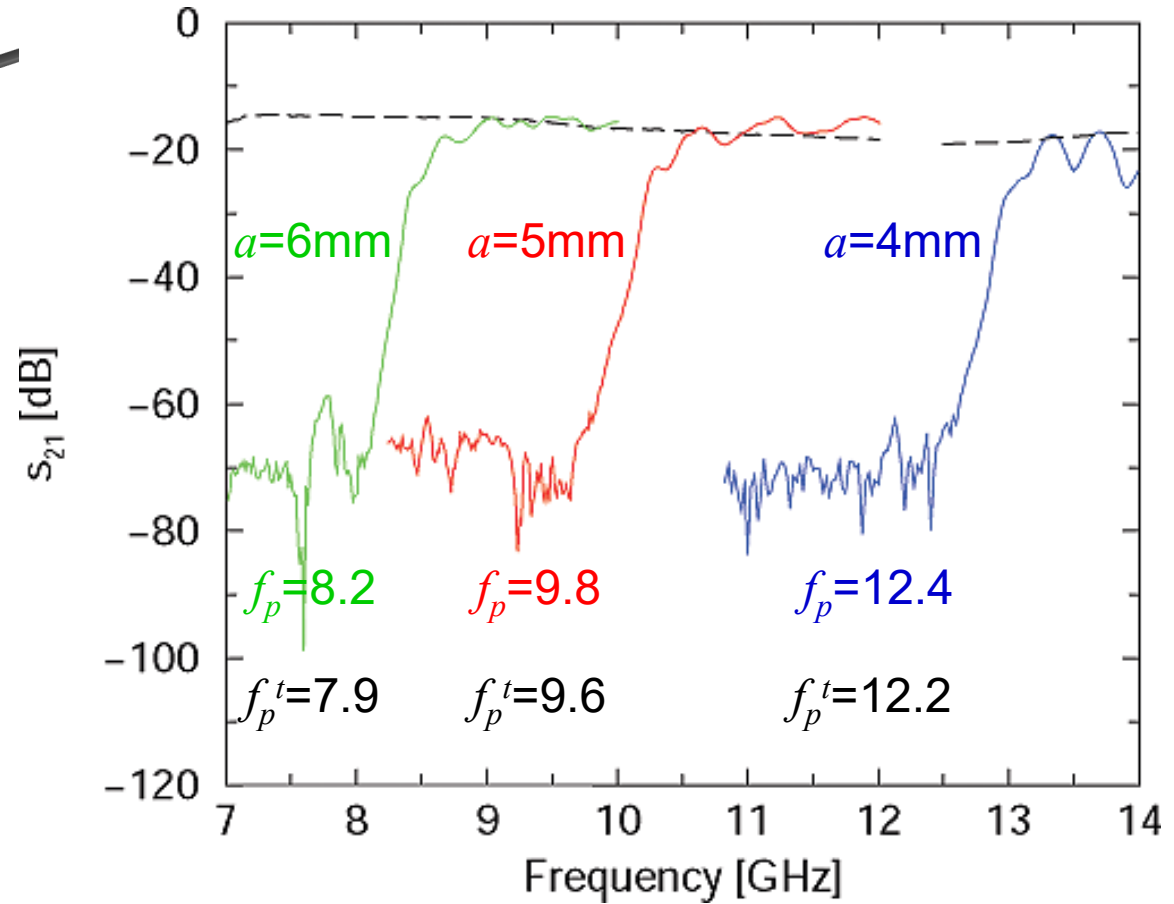

Engineering the negative permittivity – Plasma material

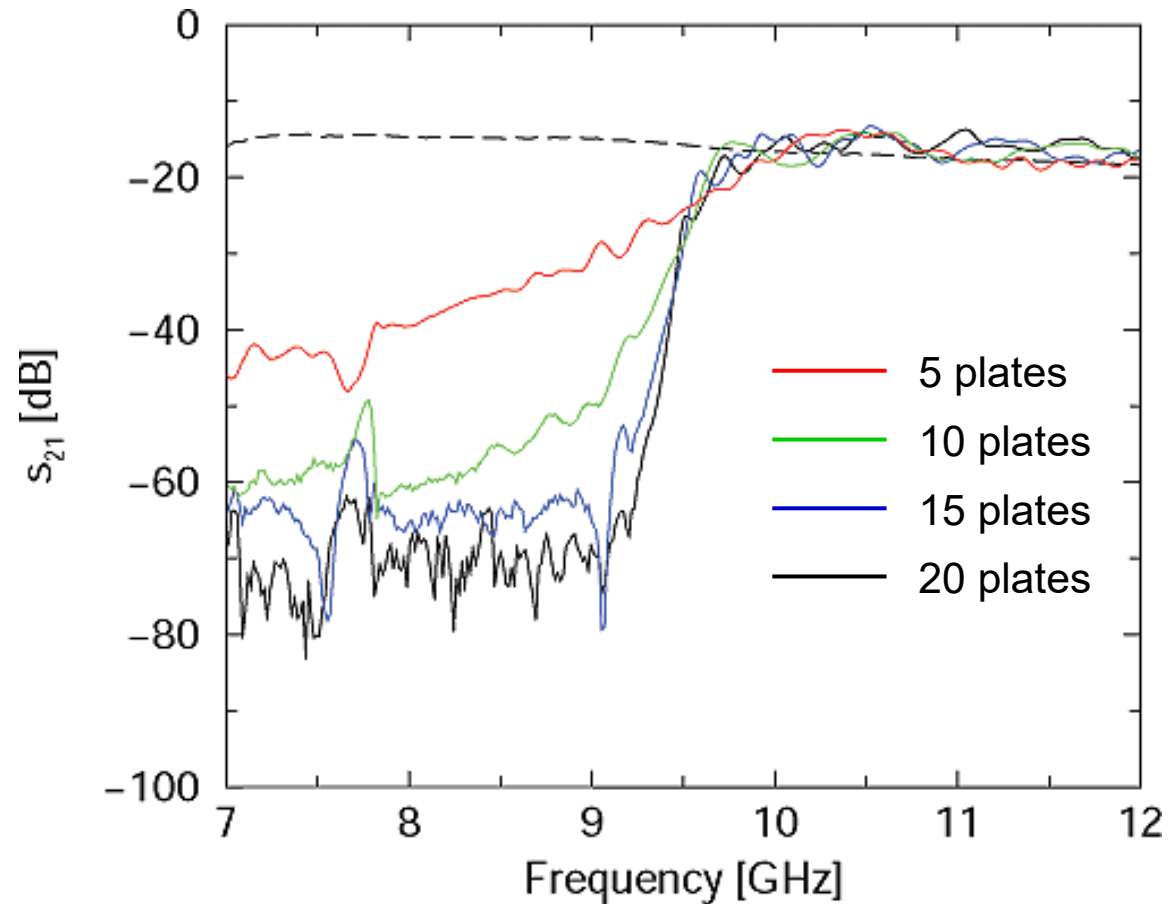

- A sample 4λ thick already behaves as an effective medium

Negative refraction metamaterials

- Snell law $n_1 \sin(\theta_1) = n_2 \sin(\theta_2)$ is reversed !

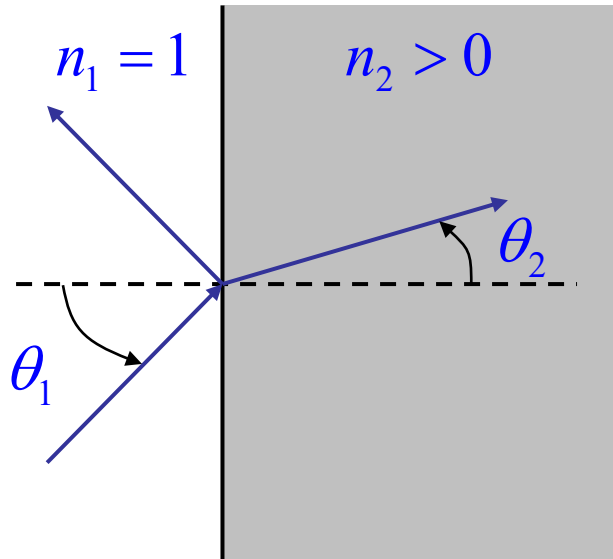

- Negative refraction:

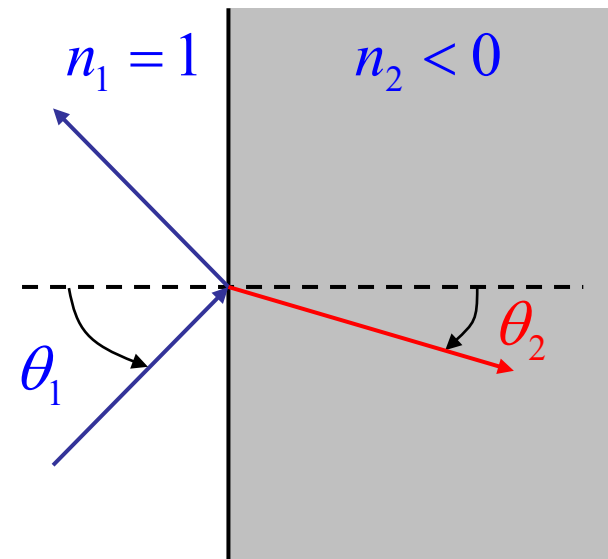

Refractive index measurement

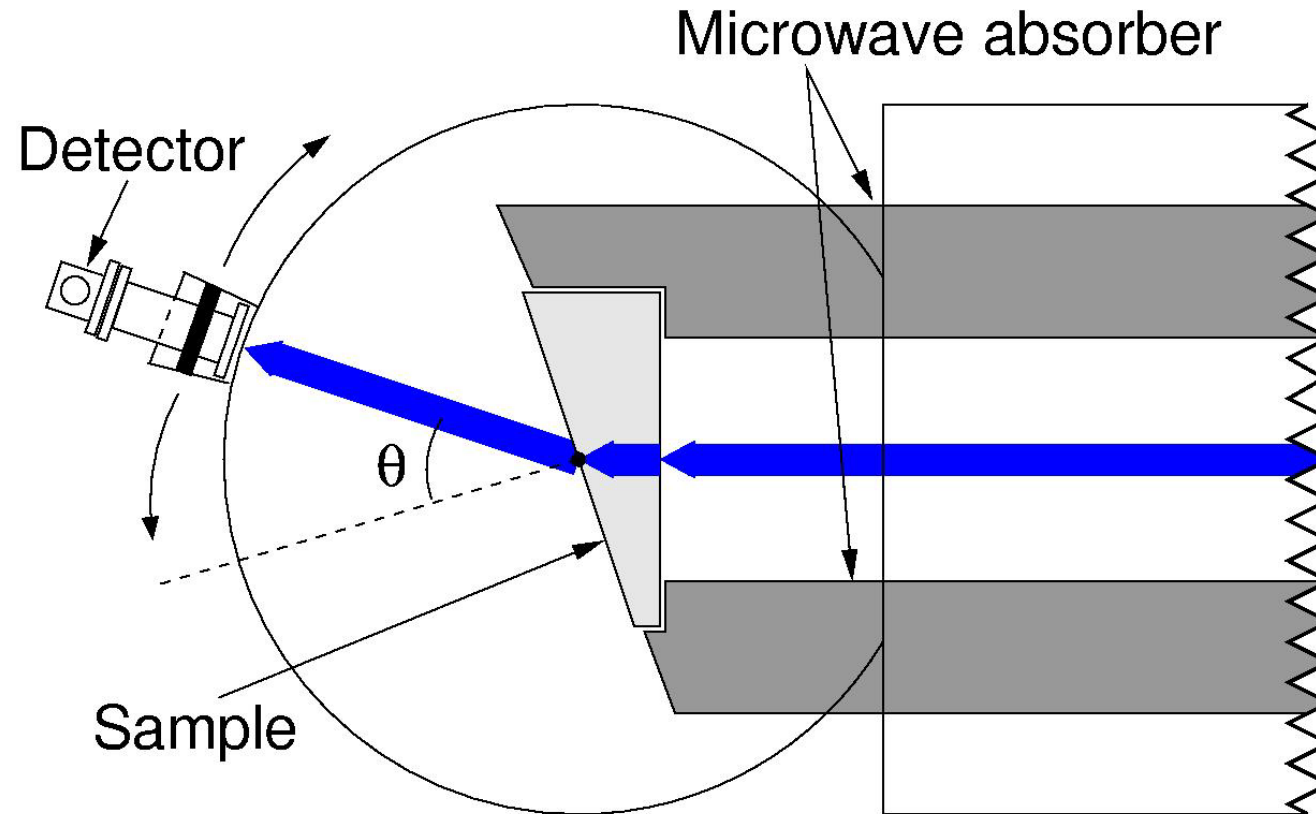

*D.R. Smith et al.
University of California in San Diego (UCSD)*

Refractive index measurement

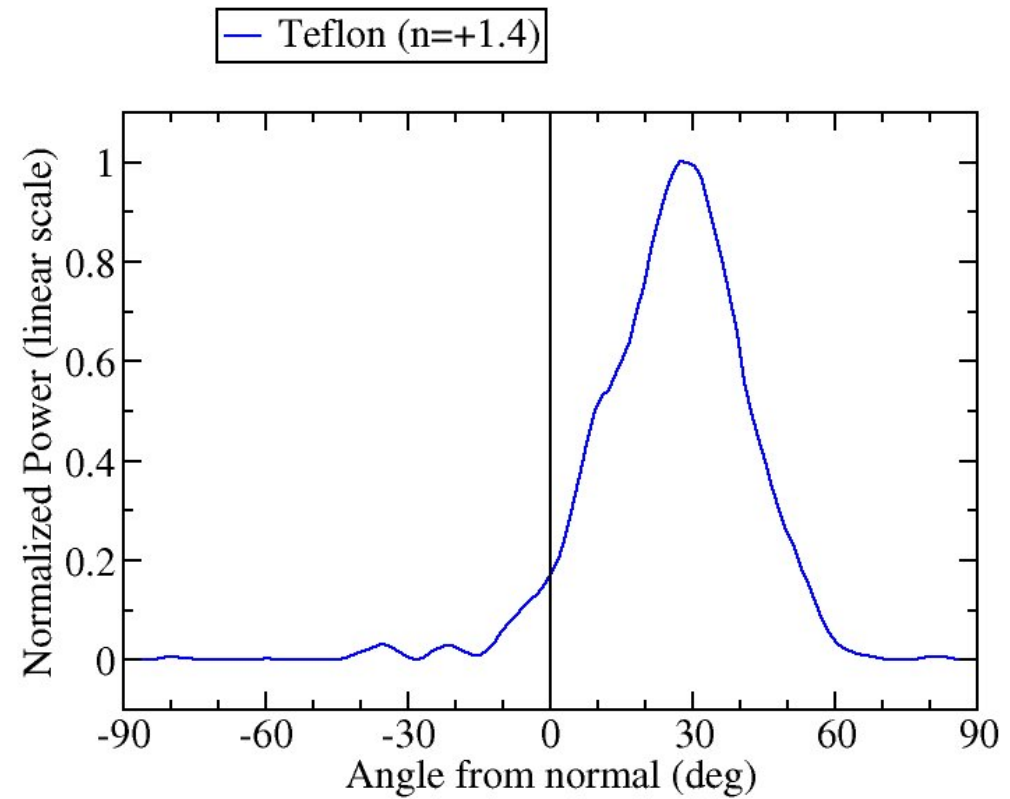
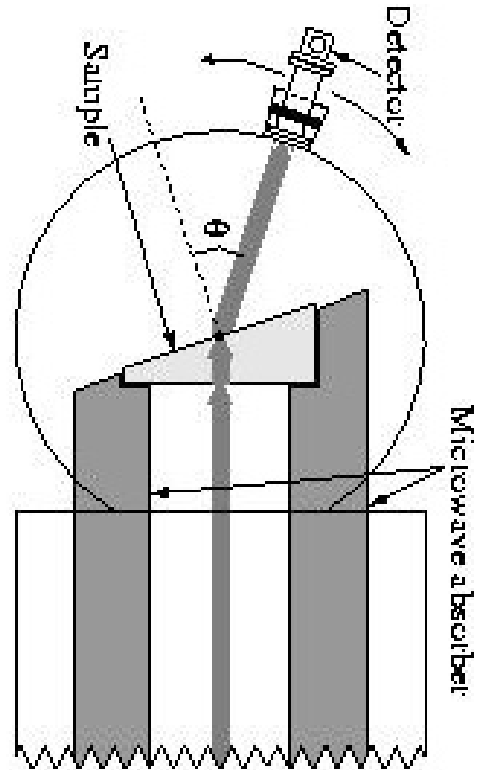

D.R. Smith et al.
University of California in San Diego (UCSD)

Refractive index measurement

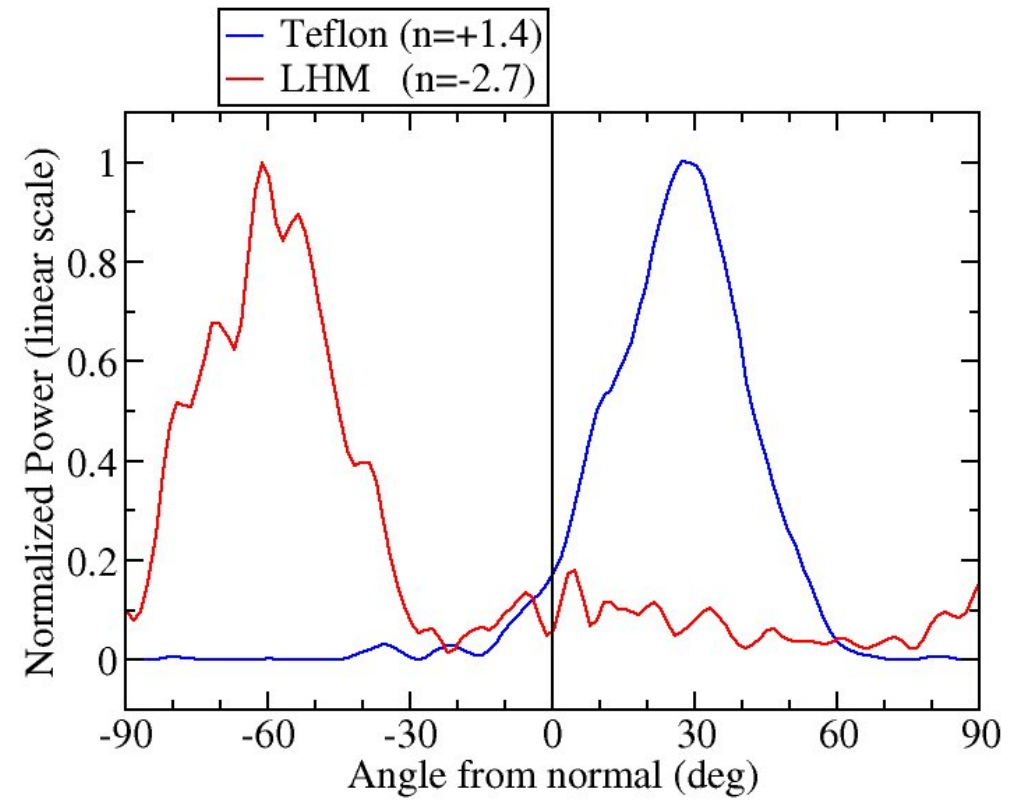
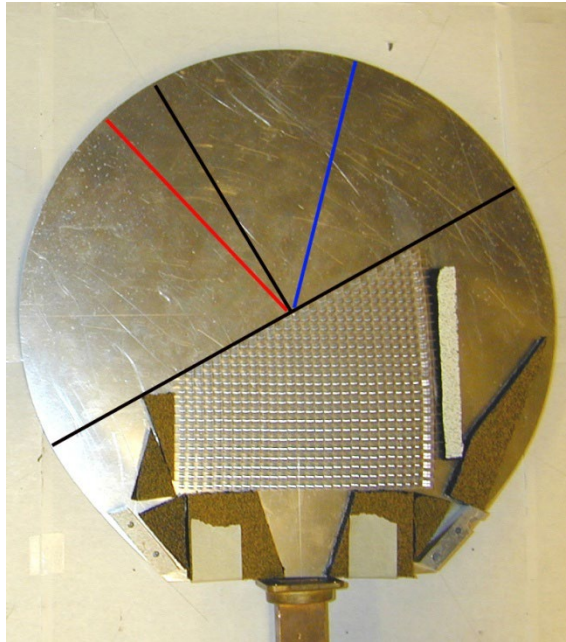

D.R. Smith et al.
University of California in San Diego (UCSD)

Selected Topics in Advanced Optics

Week 11 – part 3

Olivier J.F. Martin
Nanophotonics and Metrology Laboratory

EPFL

Electromagnetic properties and refractive index

- Normally, for a plane wave propagating in a “normal” material with $\epsilon > 0$ and $\mu > 0$, the vectors \mathbf{E} , \mathbf{H} and \mathbf{k} form a right-handed triplet:

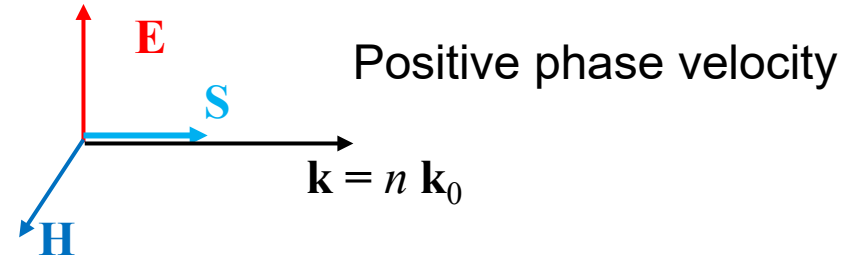

- In a material with $\epsilon < 0$ and $\mu < 0$, the vectors \mathbf{E} , \mathbf{H} and \mathbf{k} form a left-handed triplet:

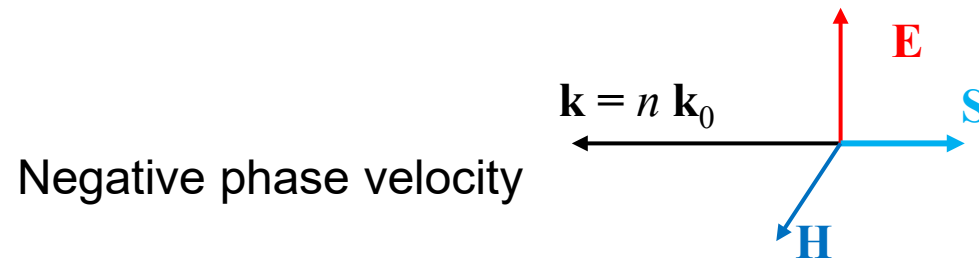

- In both cases, the Poynting vector points in the forward direction!

Electromagnetic properties and refractive index

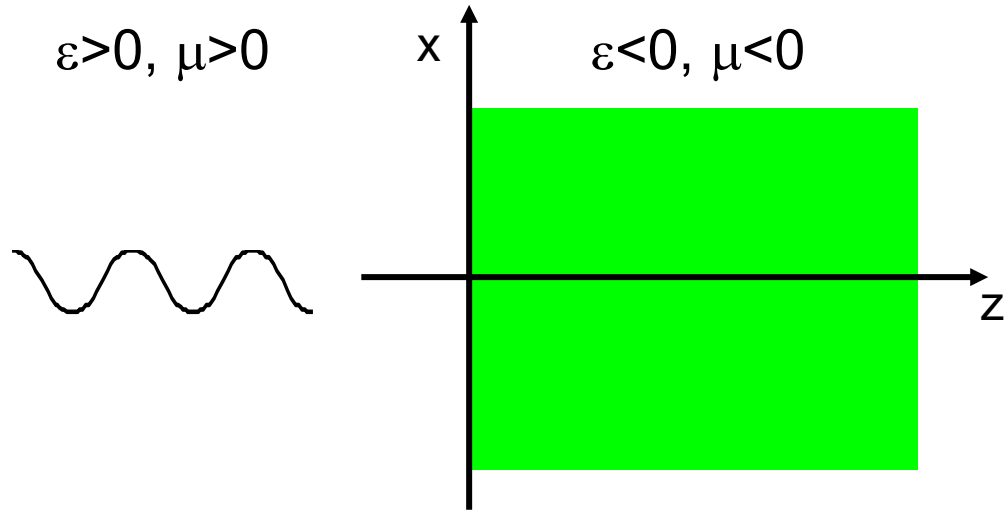

$$\exp[i\mathbf{k} \cdot \mathbf{r} - i\omega t], \quad \mathbf{k} = \begin{pmatrix} k_x \\ k_z \end{pmatrix}$$

• Dispersion relation:

$$\|\mathbf{k}\|^2 = k_x^2 + k_z^2 = \varepsilon\mu \frac{\omega^2}{c^2}$$

$$k_z = \pm \sqrt{\varepsilon\mu \frac{\omega^2}{c^2} - k_x^2}$$

$$k_x^2 < \operatorname{Re} \left[\varepsilon\mu \frac{\omega^2}{c^2} \right] \quad \text{propagating wave}$$

$$k_x^2 > \operatorname{Re} \left[\varepsilon\mu \frac{\omega^2}{c^2} \right] \quad \text{evanescent wave}$$

$$\varepsilon\mu = \varepsilon'\mu' - \varepsilon''\mu'' + i(\varepsilon'\mu'' + \varepsilon''\mu')$$

Electromagnetic properties and refractive index

$$k_z^2 = \varepsilon\mu \frac{\omega^2}{c^2} - k_x^2$$



$$k_z = \pm \sqrt{\varepsilon\mu \frac{\omega^2}{c^2} - k_x^2}$$

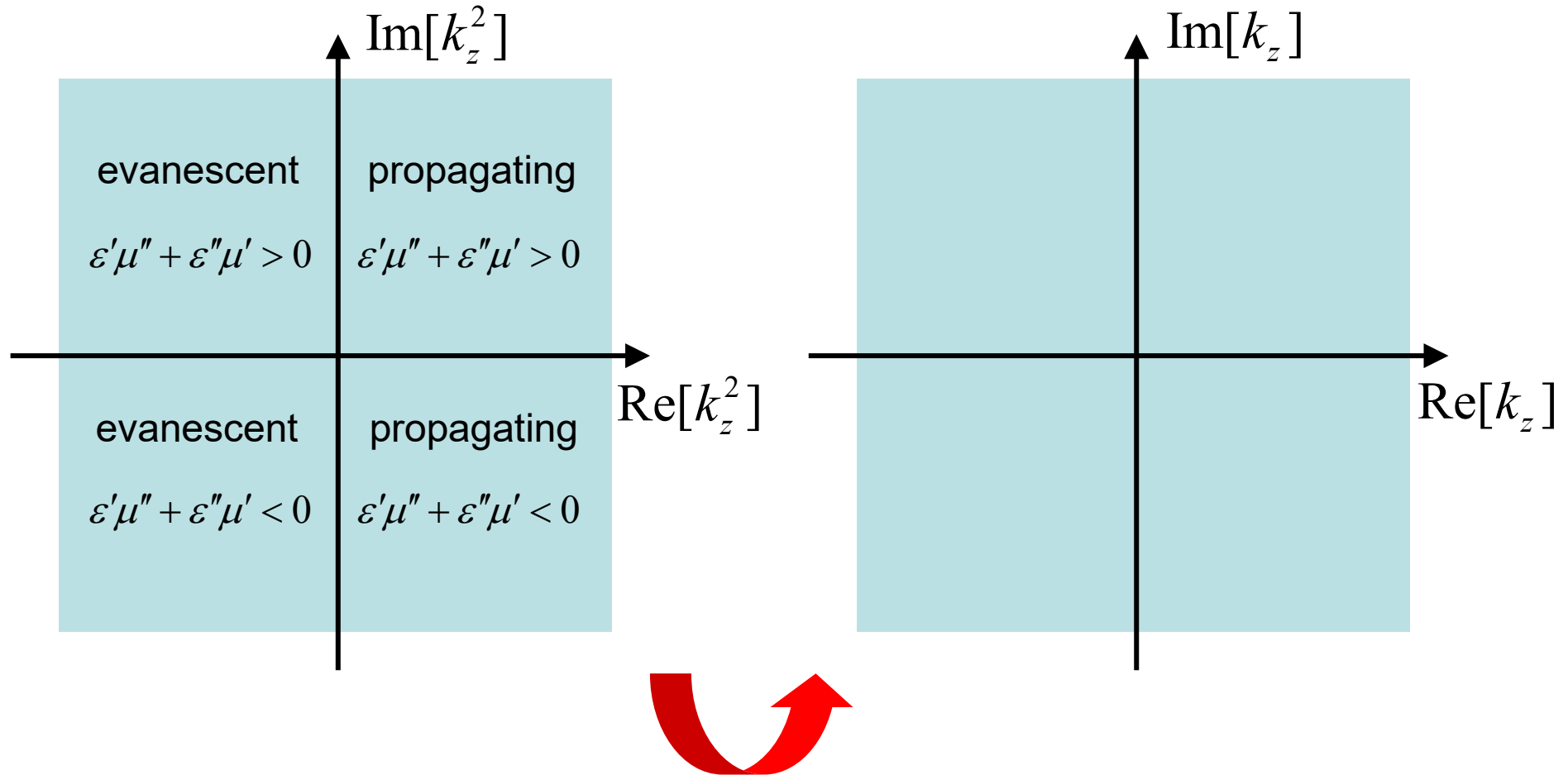

Electromagnetic properties and refractive index

$$k_z^2 = \varepsilon\mu \frac{\omega^2}{c^2} - k_x^2$$



$$k_z = \pm \sqrt{\varepsilon\mu \frac{\omega^2}{c^2} - k_x^2}$$

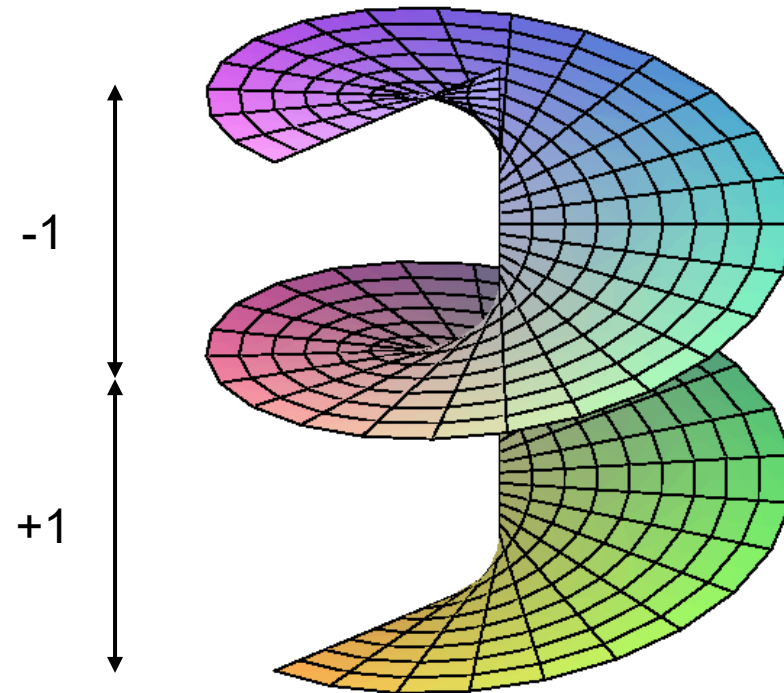
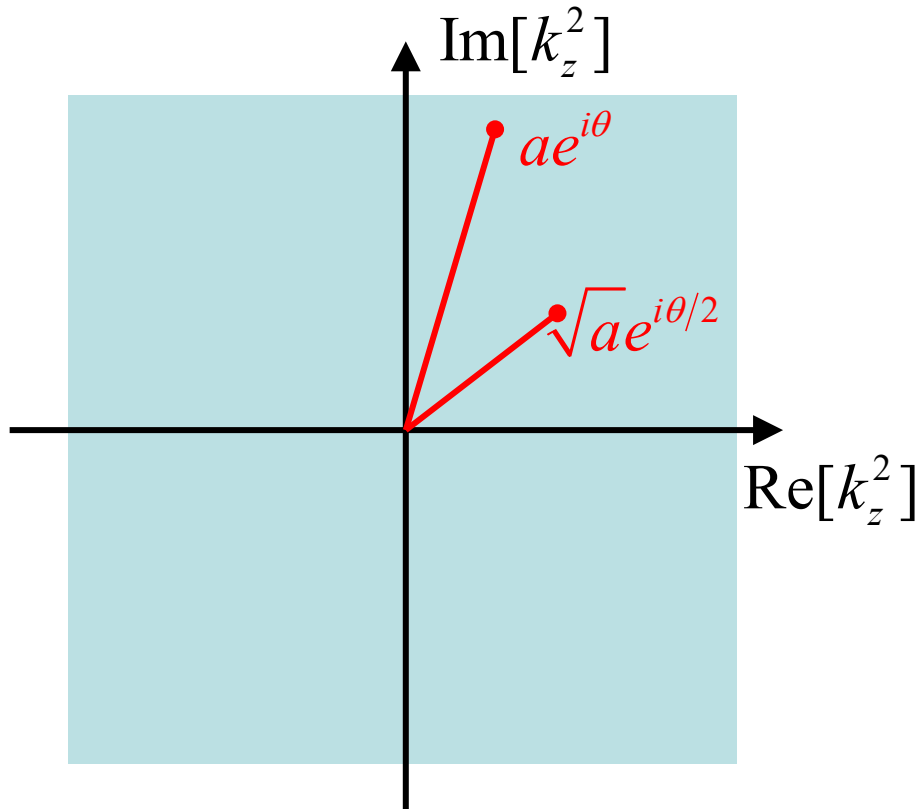

Electromagnetic properties and refractive index

$$k_z^2 = \varepsilon\mu \frac{\omega^2}{c^2} - k_x^2$$



$$k_z = \pm \sqrt{\varepsilon\mu \frac{\omega^2}{c^2} - k_x^2}$$

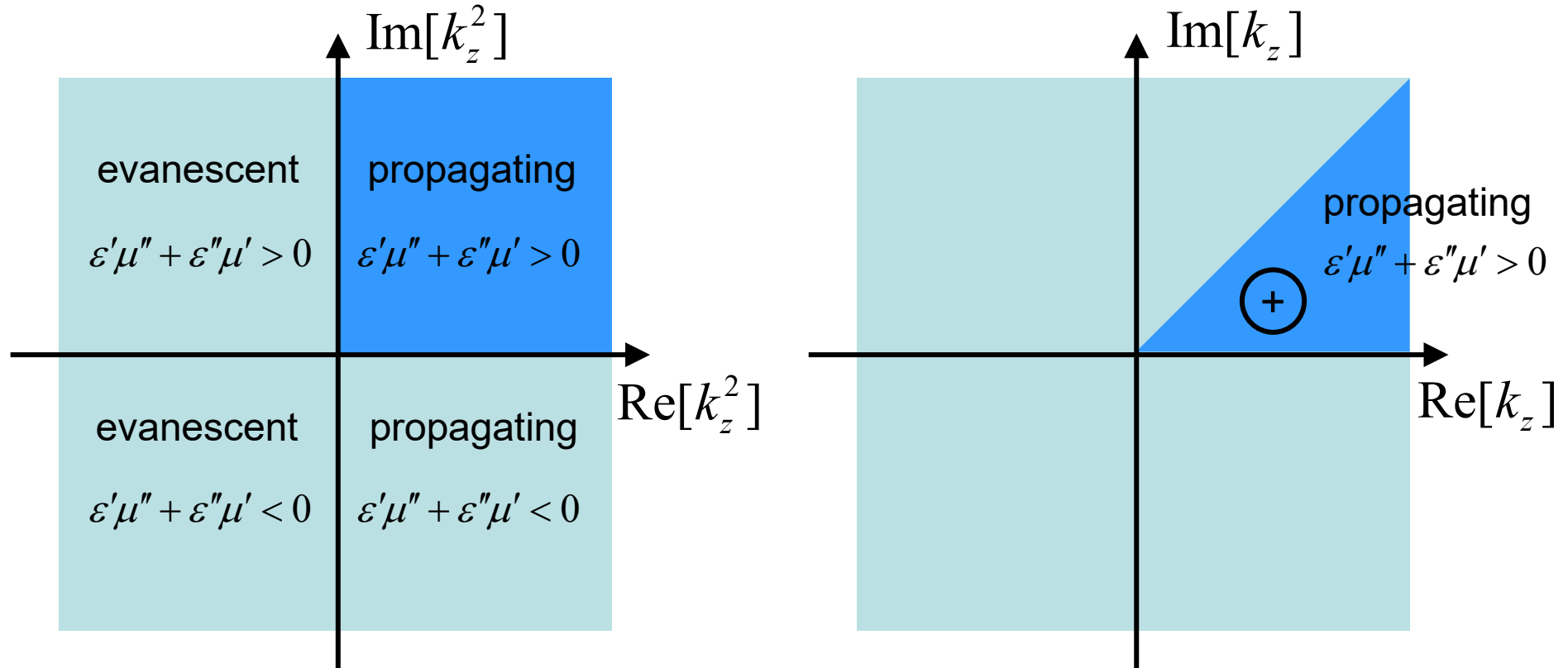

Electromagnetic properties and refractive index

$$k_z^2 = \epsilon\mu \frac{\omega^2}{c^2} - k_x^2$$



$$k_z = \pm \sqrt{\epsilon\mu \frac{\omega^2}{c^2} - k_x^2}$$

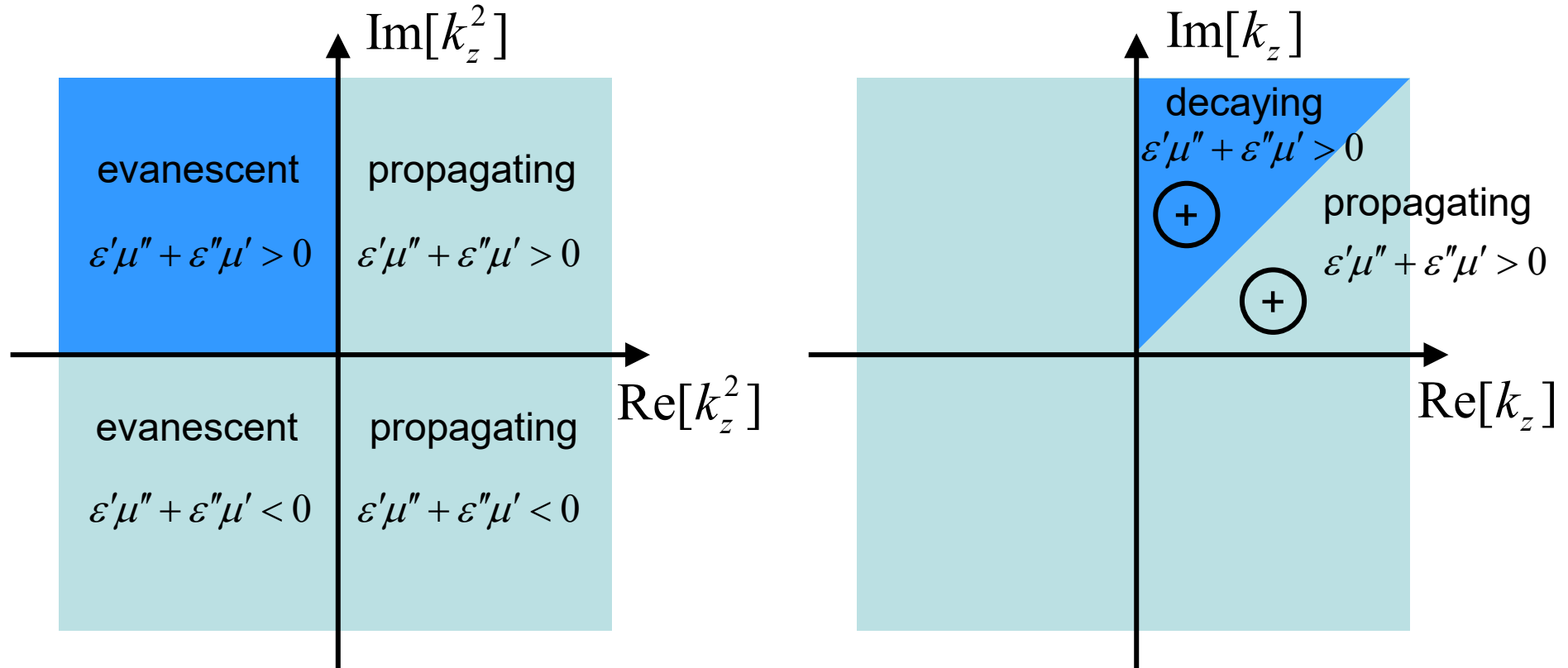

Electromagnetic properties and refractive index

$$k_z^2 = \epsilon\mu \frac{\omega^2}{c^2} - k_x^2$$



$$k_z = \pm \sqrt{\epsilon\mu \frac{\omega^2}{c^2} - k_x^2}$$

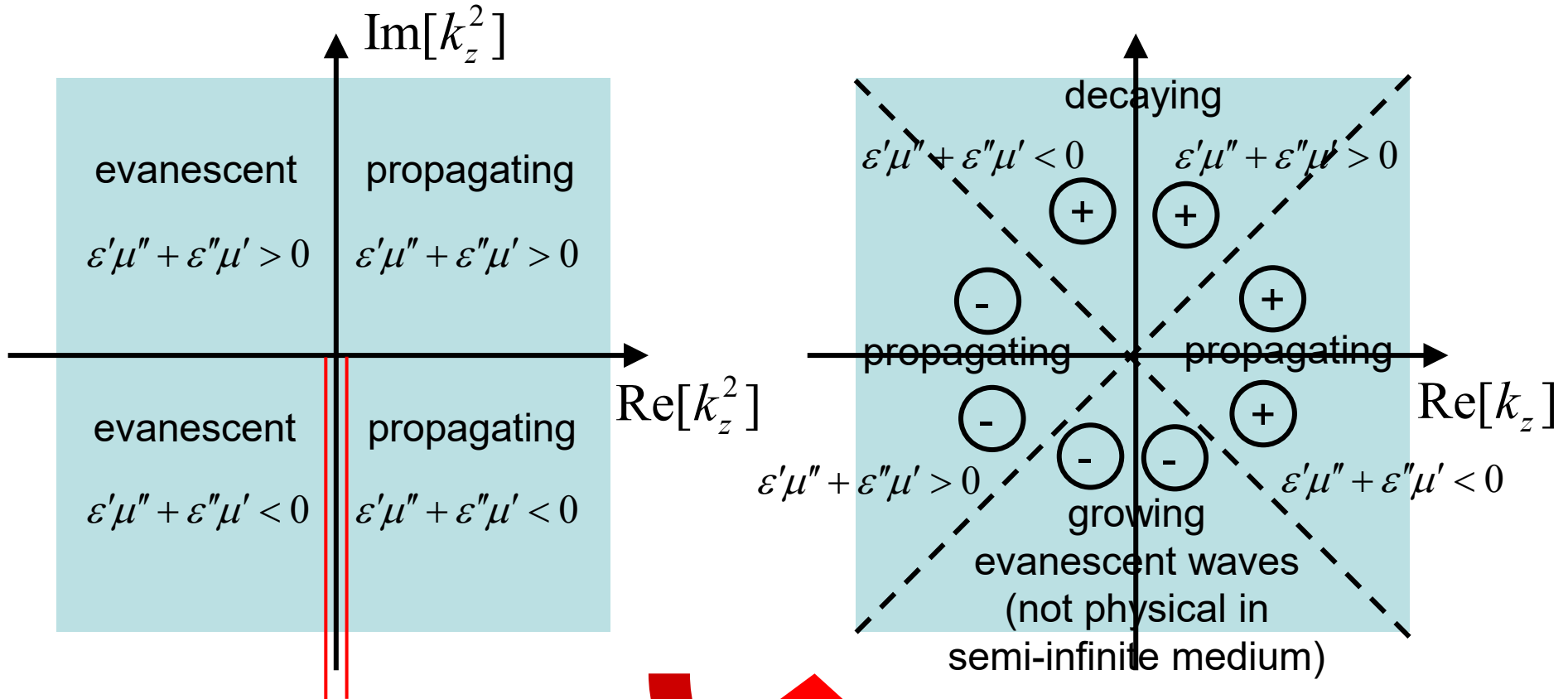

Negative Refraction Makes a Perfect Lens

J.B. Pendry

*Condensed Matter Theory Group, The Blackett Laboratory, Imperial College, London SW7 2BZ, United Kingdom
(Received 25 April 2000)*

With a conventional lens sharpness of the image is always limited by the wavelength of light. An unconventional alternative to a lens, a slab of negative refractive index material, has the power to focus all Fourier components of a 2D image, even those that do not propagate in a radiative manner. Such “superlenses” can be realized in the microwave band with current technology. Our simulations show that a version of the lens operating at the frequency of visible light can be realized in the form of a thin slab of silver. This optical version resolves objects only a few nanometers across.

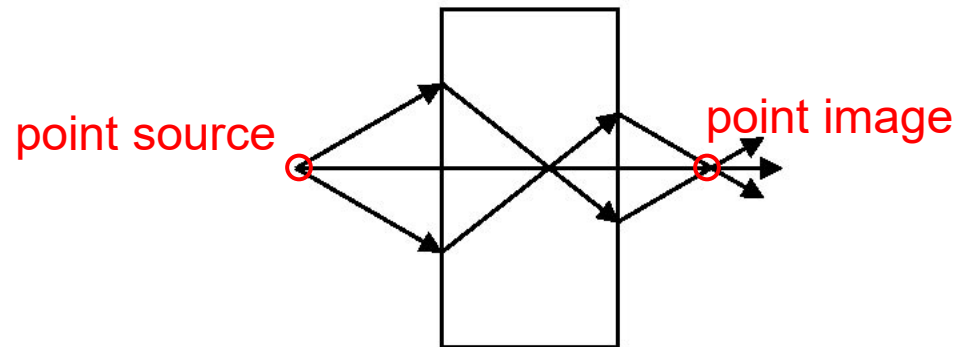

FIG. 1. A negative refractive index medium bends light to a negative angle with the surface normal. Light formerly diverging from a point source is set in reverse and converges back to a point. Released from the medium the light reaches a focus for a second time.

- The optical path in the material «compensates» the optical path in the surrounding

Perfect lens and negative refraction

SOVIET PHYSICS USPEKHI

VOLUME 10, NUMBER 4

JANUARY-FEBRUARY 1968

538.30

THE ELECTRODYNAMICS OF SUBSTANCES WITH SIMULTANEOUSLY NEGATIVE VALUES OF ϵ AND μ

V. G. VESELAGO

P. N. Lebedev Physics Institute, Academy of Sciences, U.S.S.R.

Usp. Fiz. Nauk 92, 517-526 (July, 1964)

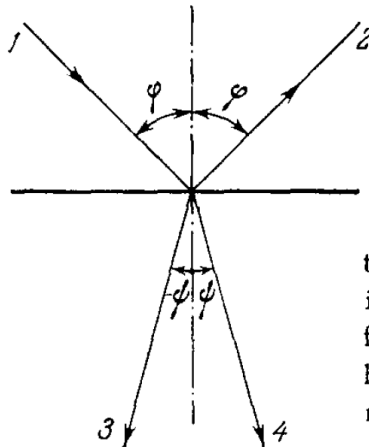

FIG. 3. Passage of a ray through the boundary between two media. 1 – incident ray; 2 – reflected ray; 3 – reflected ray if the second medium is left-handed; 4 – refracted ray if the second medium is right-handed.

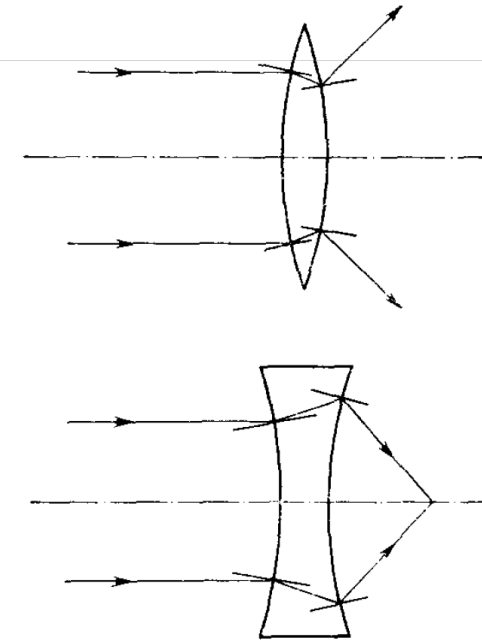
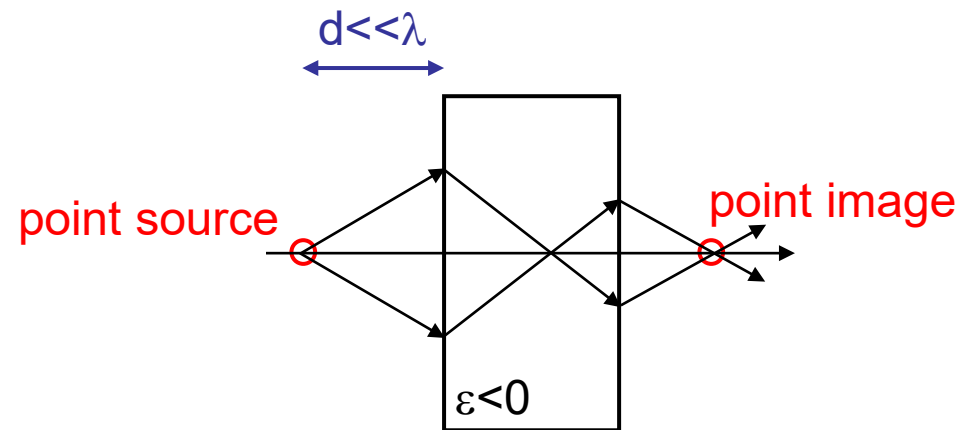

FIG. 5. Paths of rays through lenses made of left-handed substances, situated in vacuum.

Perfect lens

- How can we utilize this effect at optical frequencies ?
- $\mu < 0$ is very difficult to obtain
- however, $\epsilon < 0$ might be sufficient:



Near-field perfect lens

- Every material is characterized by its permittivity ϵ and its permeability μ

SOVIET PHYSICS USPEKHI

VOLUME 10, NUMBER 4

JANUARY-FEBRUARY 1968

38.30

*THE ELECTRODYNAMICS OF SUBSTANCES WITH SIMULTANEOUSLY NEGATIVE
VALUES OF ϵ AND μ*

V. G. VESELAGO

P. N. Lebedev Physics Institute, Academy of Sciences, U.S.S.R.

Usp. Fiz. Nauk 92, 517-526 (July, 1964)

- Solutions of the wave equation:

$$\nabla^2 \mathbf{E} = \epsilon \mu \frac{\partial^2 \mathbf{E}}{\partial t^2}$$

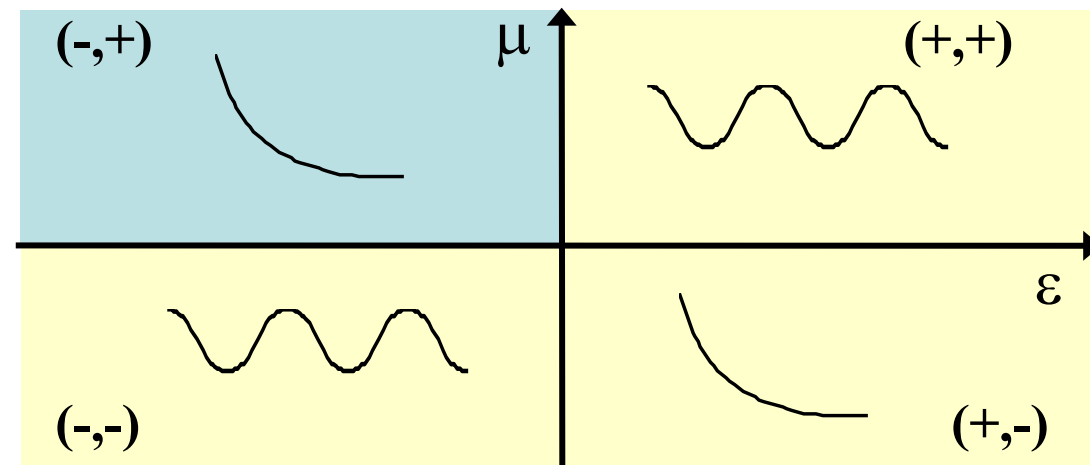

Near-field perfect lens

- How can we utilize this effect at optical frequencies ?
- Is $\epsilon < 0$ sufficient?

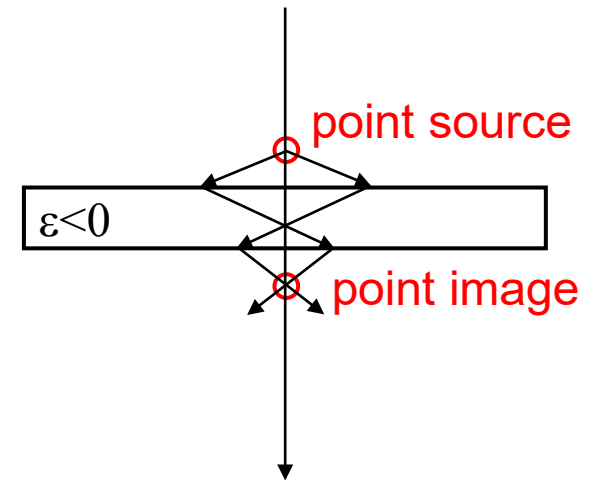
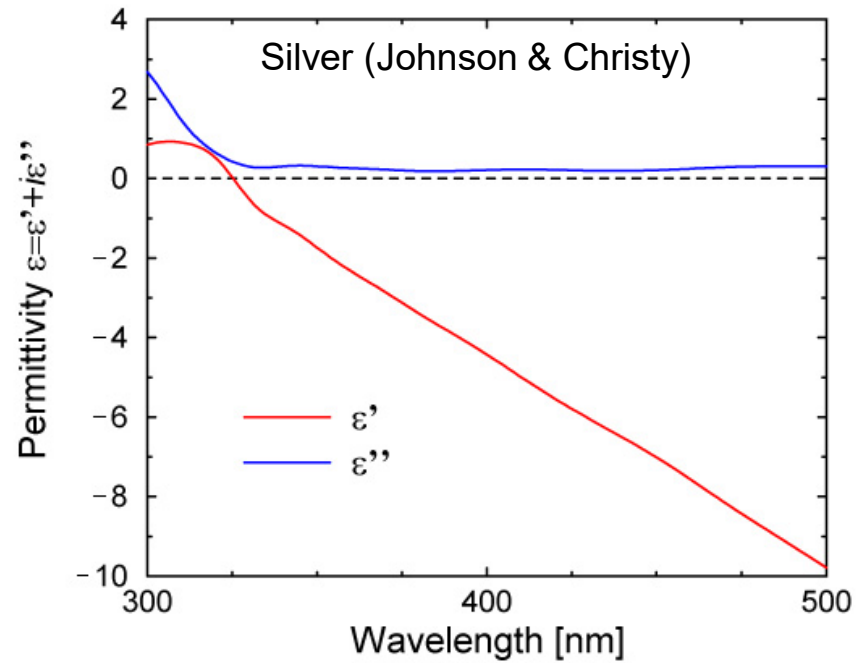

Near-field perfect lens

- How can we utilize this effect at optical frequencies ?
- Absorption kills the perfect lens effect !

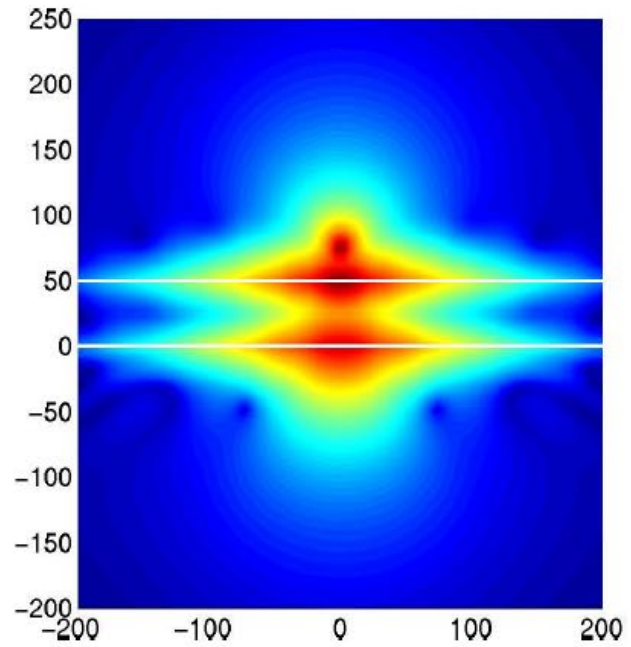

$$\varepsilon = -1 + 0.01i$$

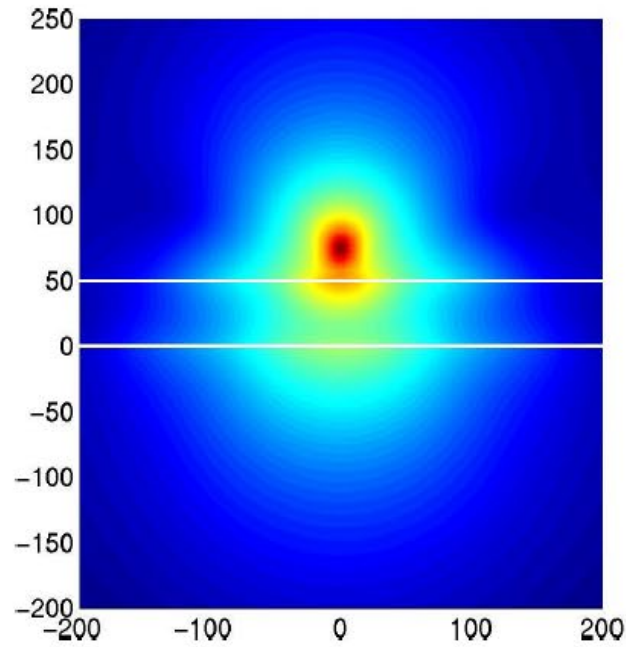

$$\varepsilon = -1 + 0.5i$$

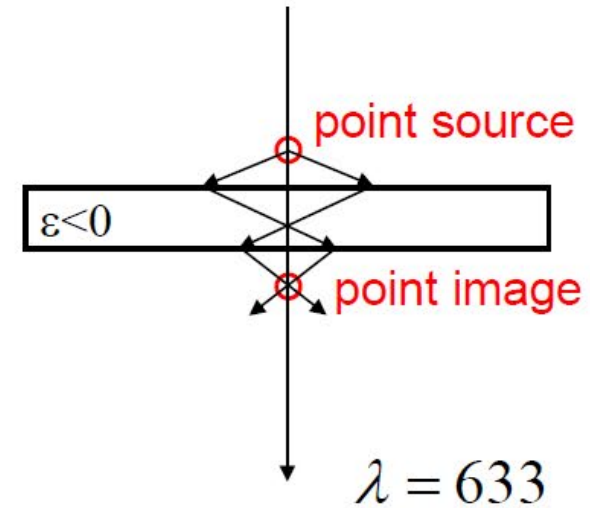

Near-field perfect lens

- Experimental realization: a silver superlens increases the resolution

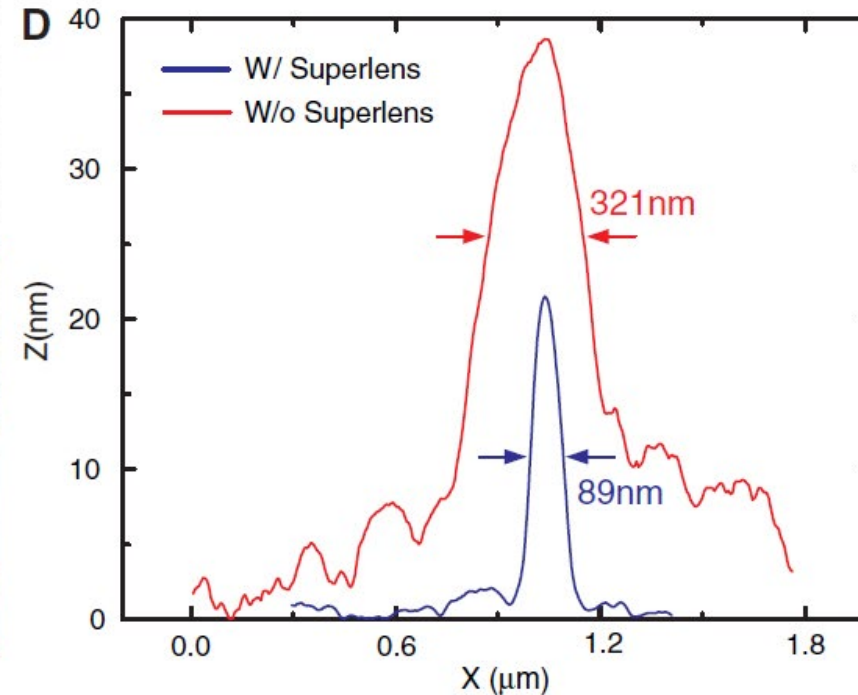
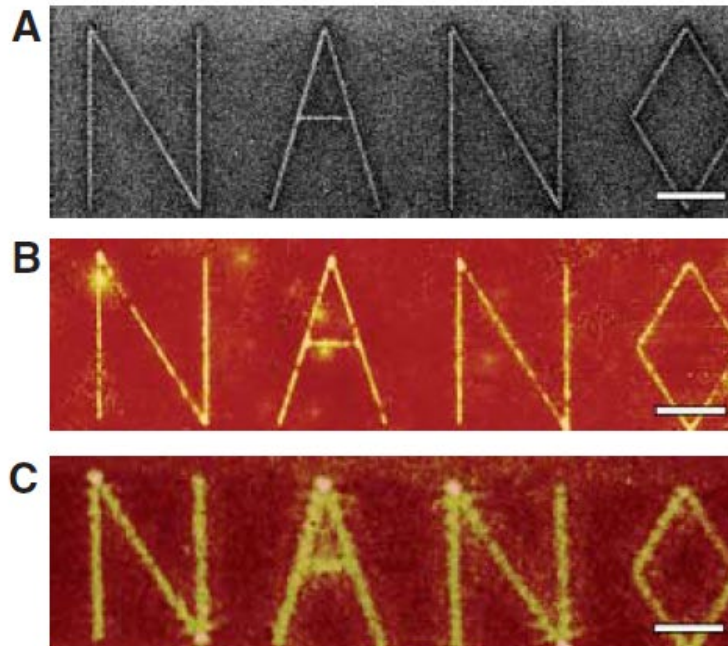
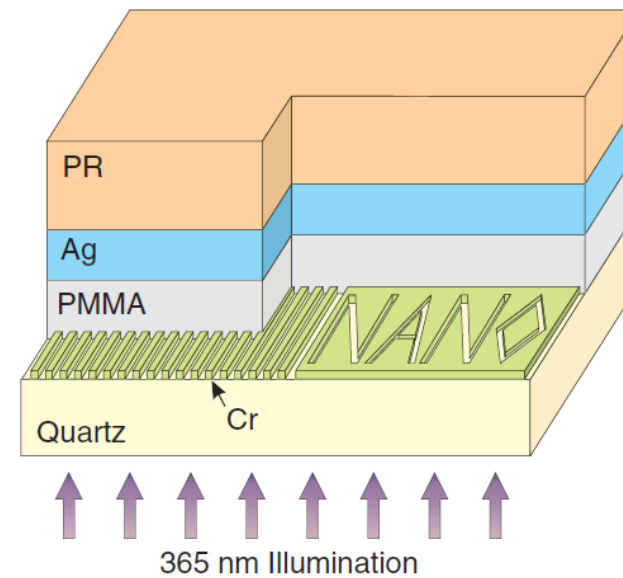

Near-field perfect lens in the infrared

- Using phonon polaritons, at $\lambda=10.85\mu\text{m}$
- 500 nm hole ($\lambda/20$) can be resolved

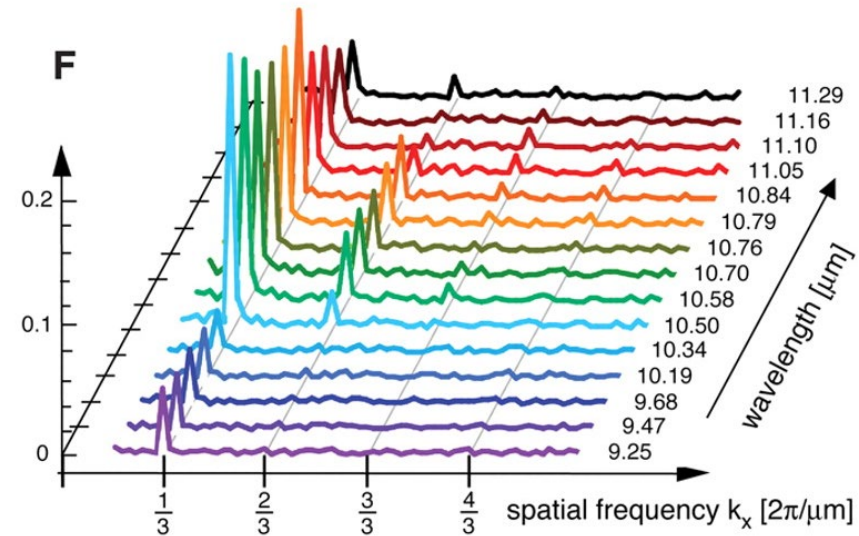
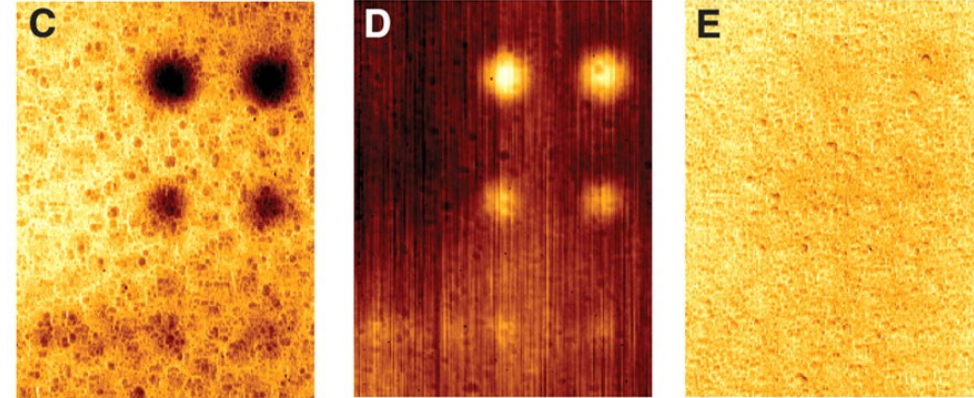
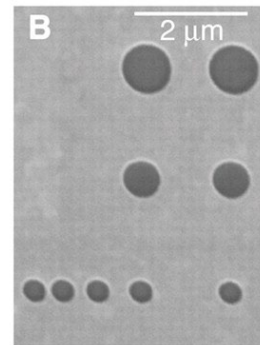
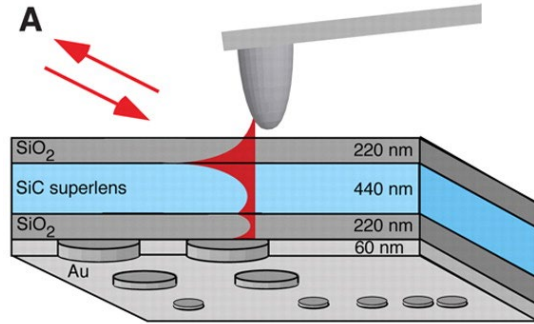

Selected Topics in Advanced Optics

Week 11 – part 4

Olivier J.F. Martin
Nanophotonics and Metrology Laboratory

EPFL

Scaling up to higher frequencies

- As long as one remains in the microwave regime, one can simply scale the dimensions down:

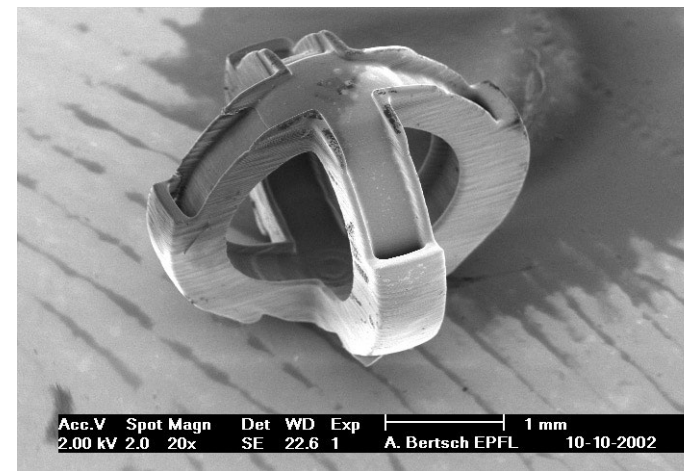
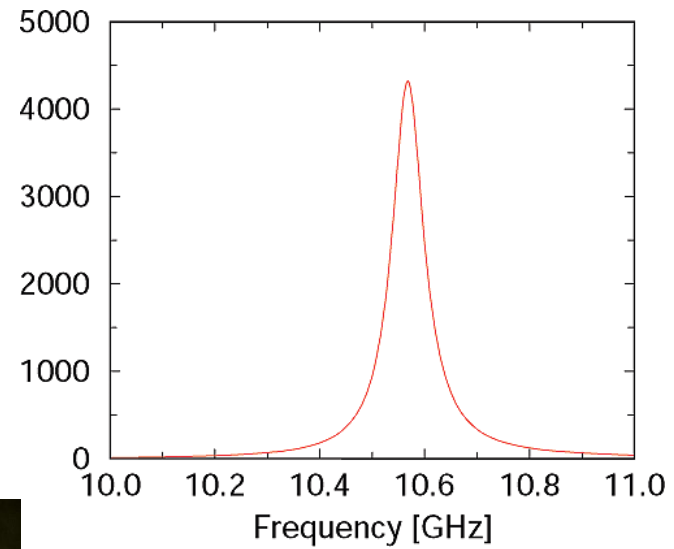
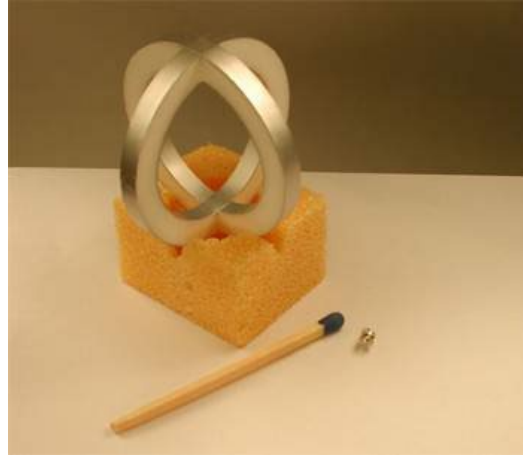

Scaling up to higher frequencies

- However, this simple geometrical scaling has limits when one wishes to go to optical frequencies
- In particular, intrinsic losses in the metal limit the electron motion at very high frequencies (plasmonic effects)

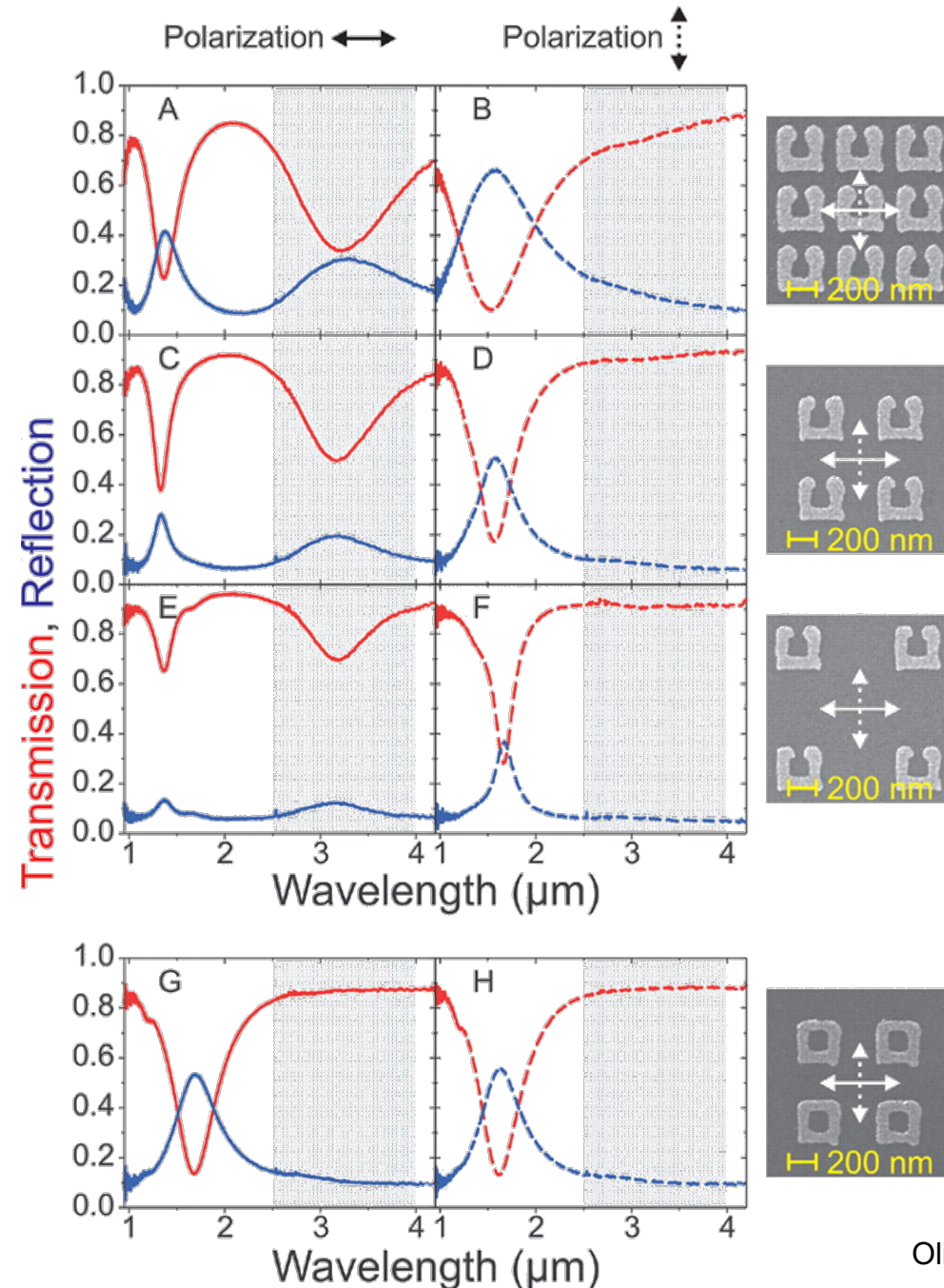

Scaling up to higher frequencies

- It is also extremely difficult to produce a true 3D material for optical frequencies

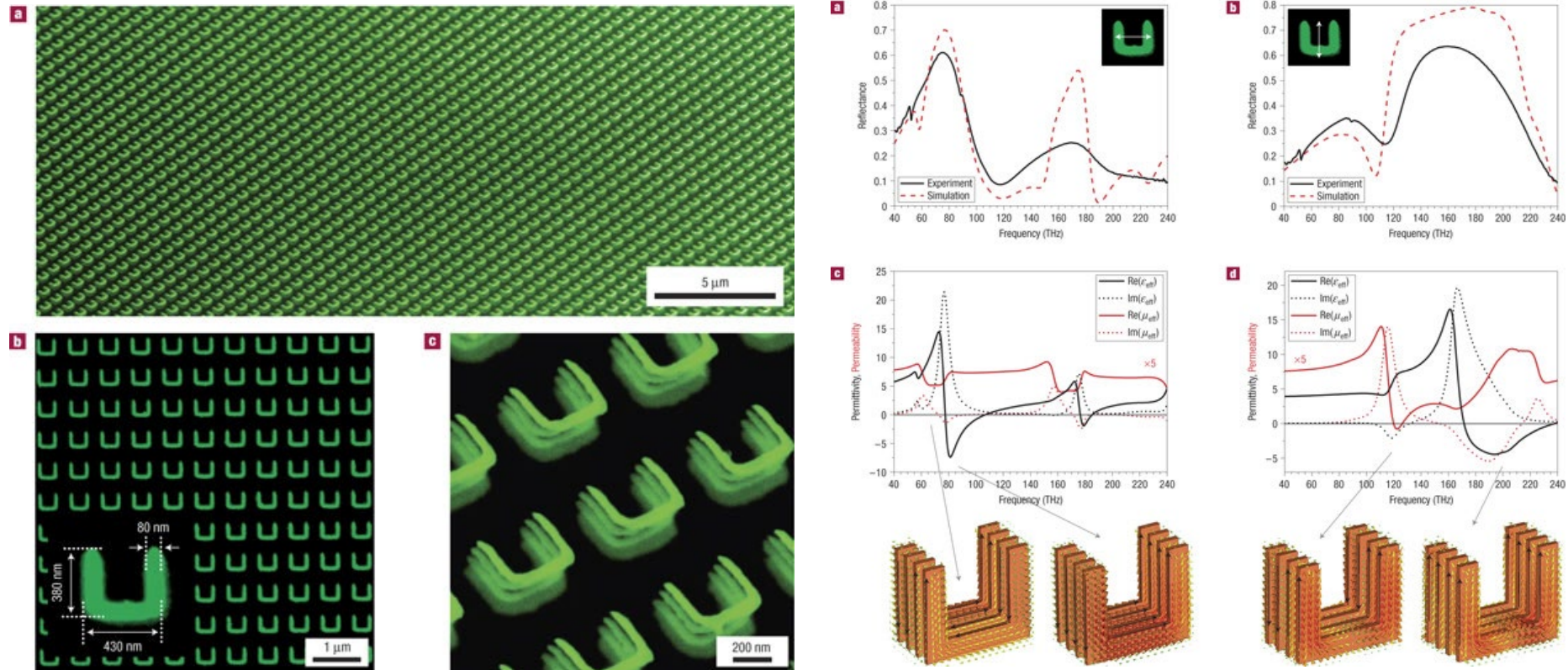

Scaling up to higher frequencies

- It is also extremely difficult to produce a true 3D material for optical frequencies

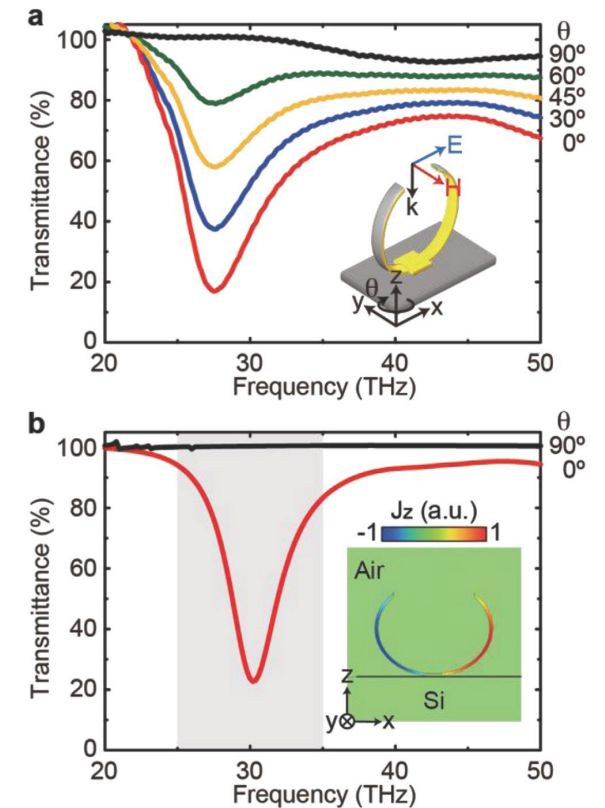
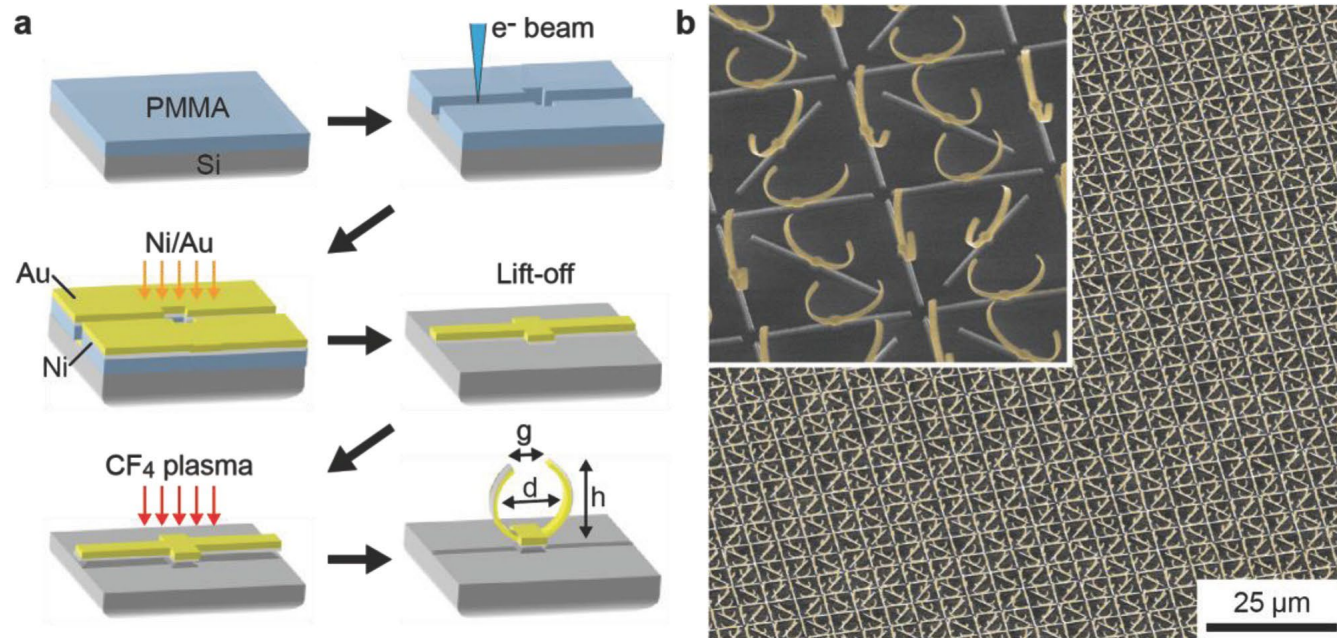

Scaling up to higher frequencies

- It is also extremely difficult to produce a true 3D material for optical frequencies

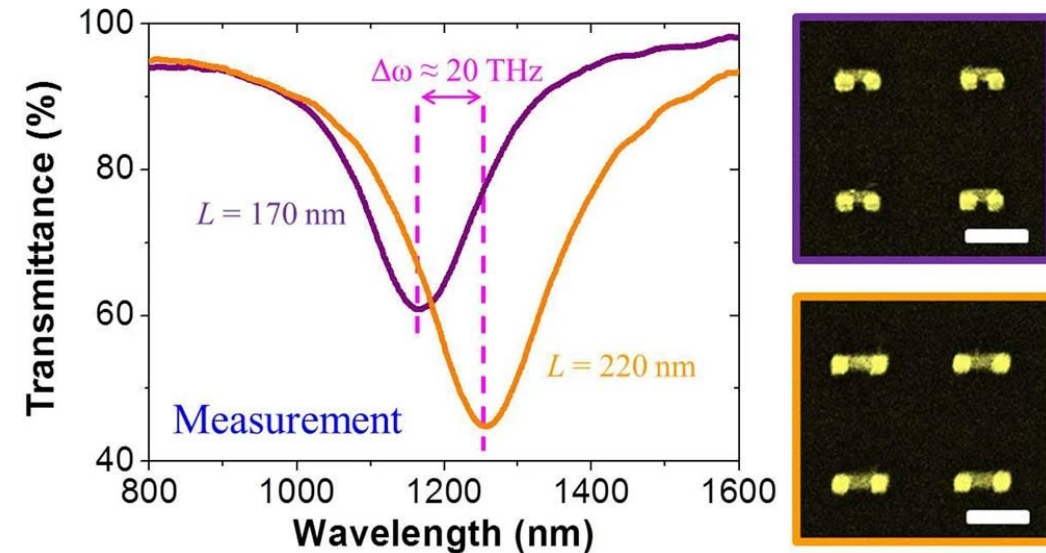
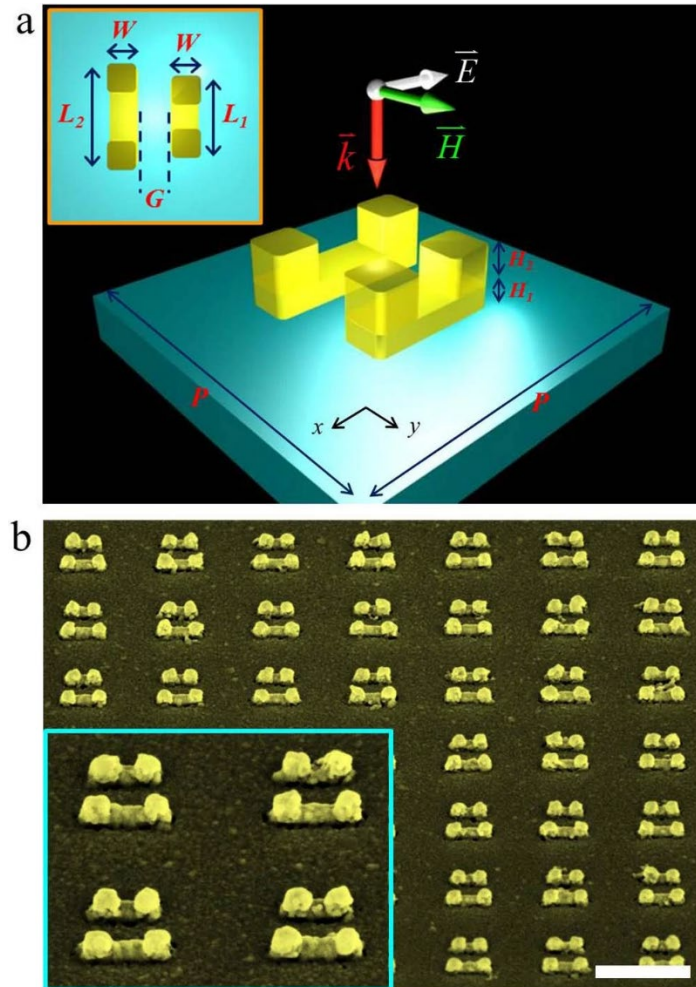

Scaling up to higher frequencies

- It is also extremely difficult to produce a true 3D material for optical frequencies

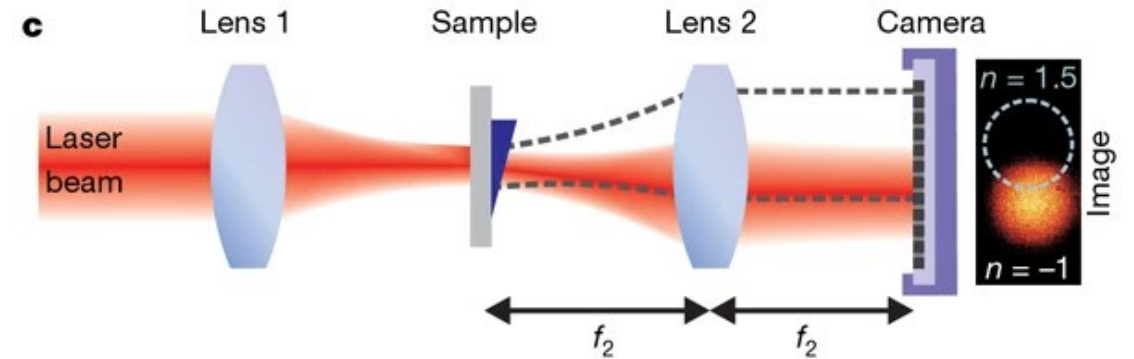
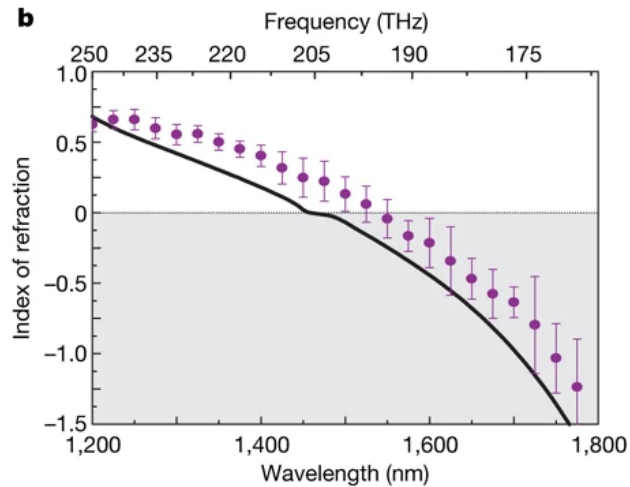
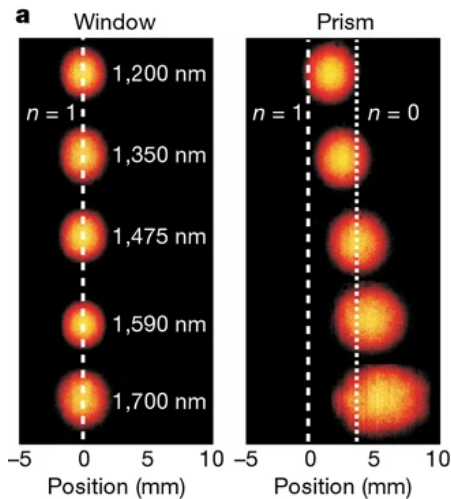
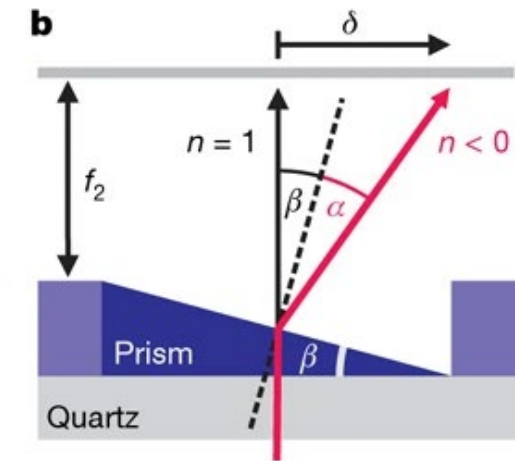
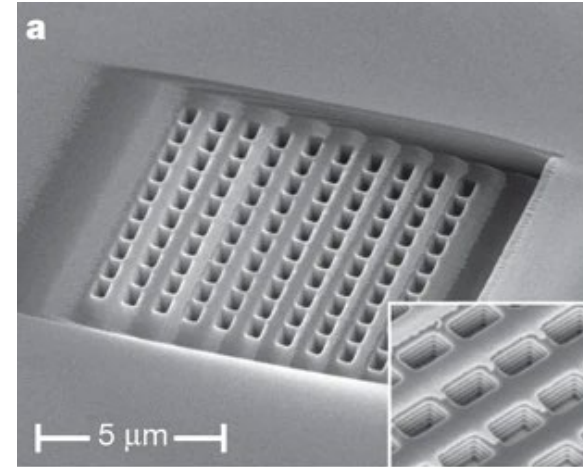
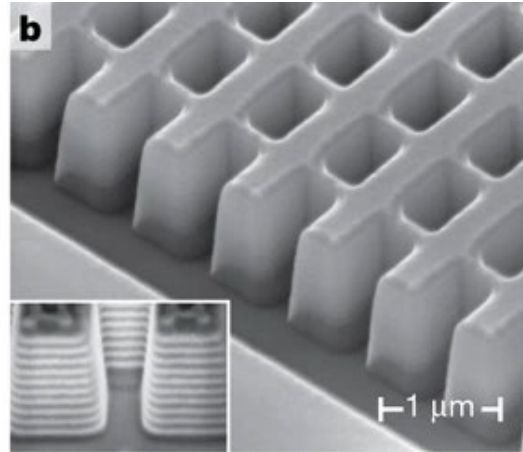
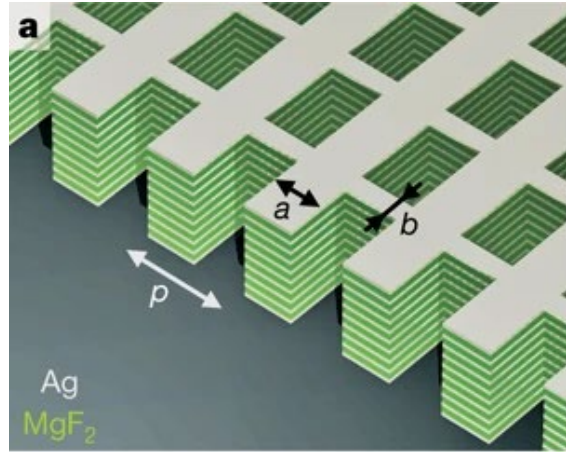

Scaling up to higher frequencies

- Overall, moving to optical frequencies requires a completely new approach for producing "magnetic resonances"

