

# Selected Topics in Advanced Optics

---

## Week 12 – part 1

Olivier J.F. Martin  
Nanophotonics and Metrology Laboratory

**EPFL**

# Metasurfaces

- It is quite challenging to fabricate a true 3D metamaterial, especially at optical frequencies
- A surface, structured with nanostructures, can already provide very interesting and useful features

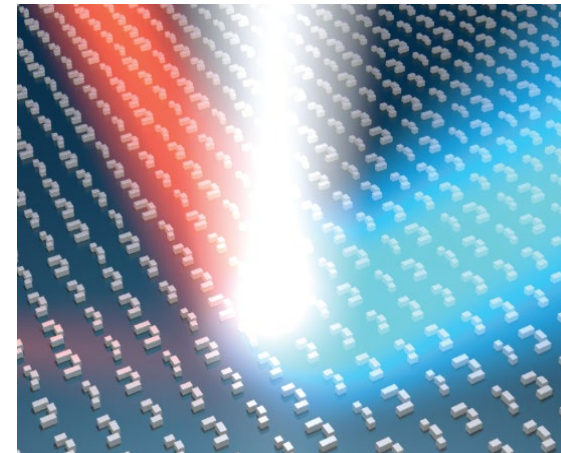
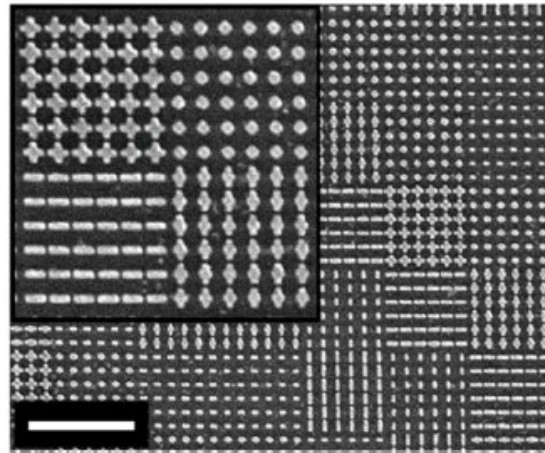
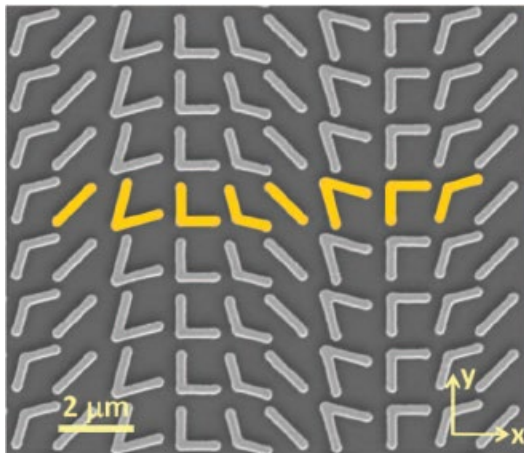

# Metamaterials and metasurfaces

## Metamaterial

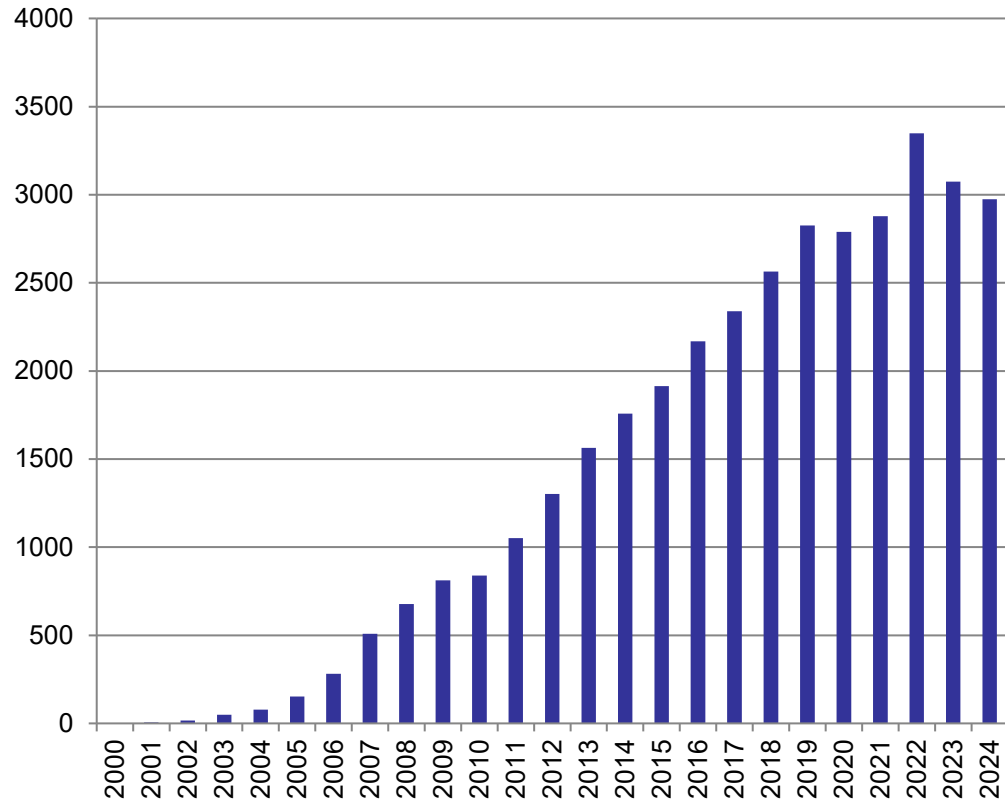

## Metasurface

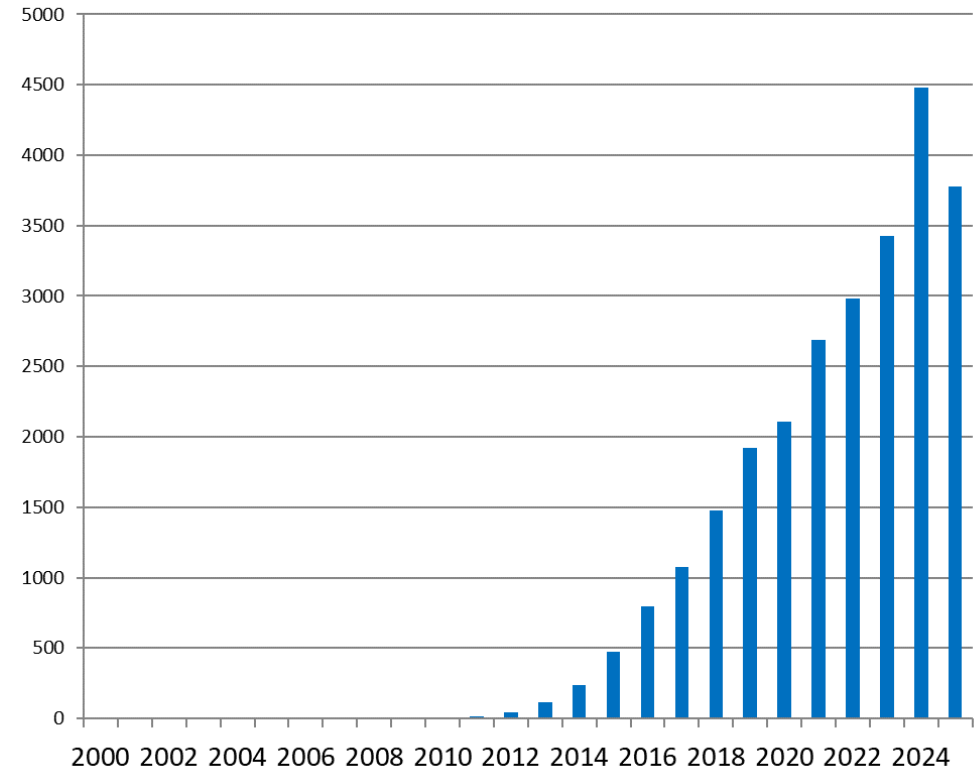

## Generalized Snell's law

- The interface between the two media is artificially structured in order to introduce an abrupt phase shift  $\phi$  in the light path, which is a function of the position  $x$  along the interface; this phase shift must be taken into the Snell law:

$$n_t \sin \theta_t - n_i \sin \theta_i = 0$$

Snell's law

$$n_t \sin \theta_t - n_i \sin \theta_i = \frac{\lambda_0}{2\pi} \frac{d\Phi}{dx}$$

Generalized Snell's law

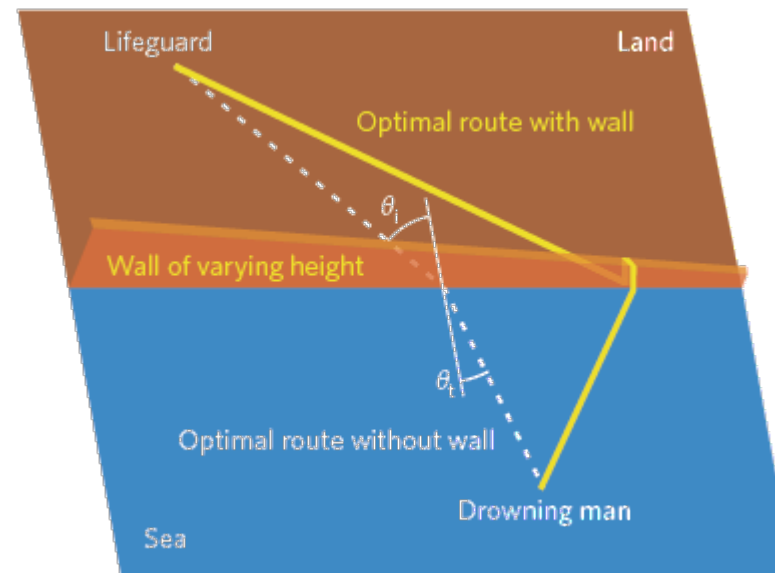
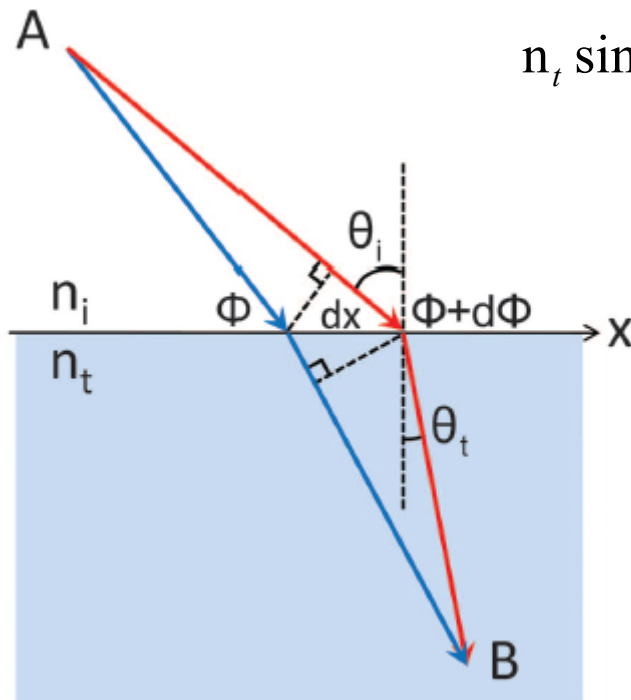

Science vol. 334, p. 333 (2011)

# Generalized Snell's law

- A grating provides a monotonously growing phase along the interface:

$$n_t \sin \theta_t - n_i \sin \theta_i = \frac{\lambda_0}{2\pi} \frac{2\pi}{\Lambda} \quad \text{Grating law}$$

$$n_t \sin \theta_t - n_i \sin \theta_i = \frac{\lambda_0}{2\pi} \frac{d\Phi}{dx} \quad \text{Generalized Snell's law}$$

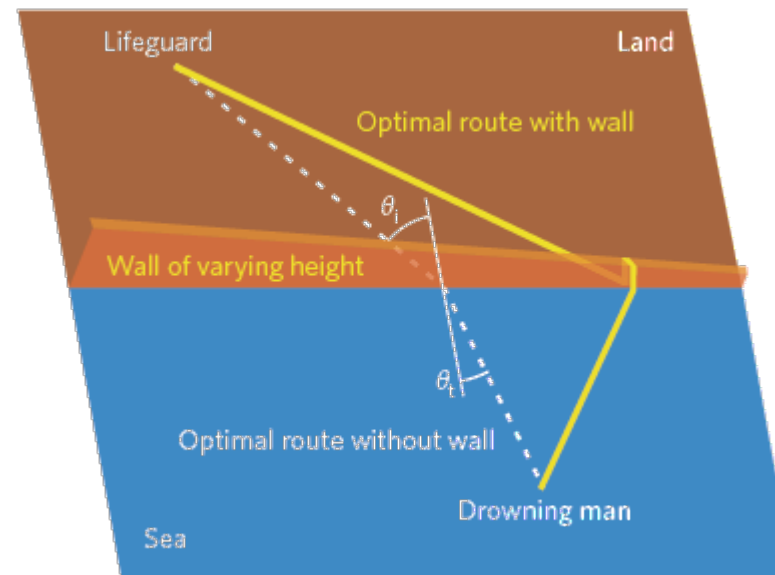
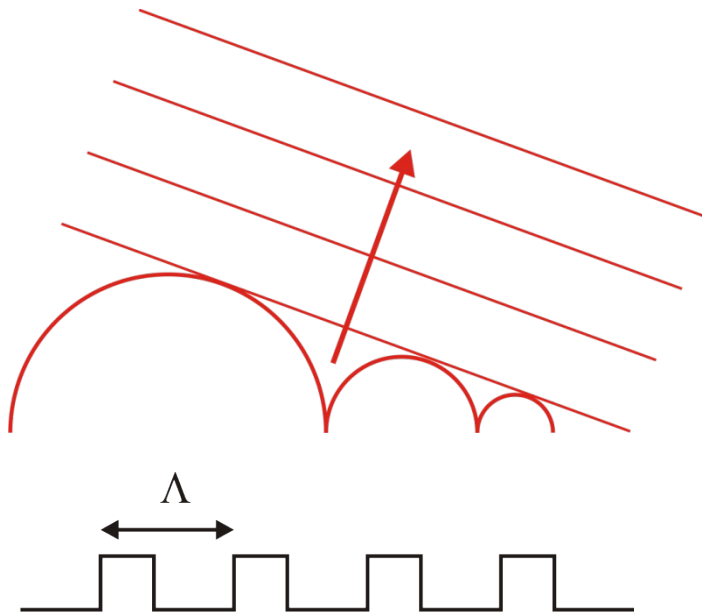

Science vol. 334, p. 333 (2011)

## Generalized Snell's law

- A plasmonic nanostructure also produces a phase shift (which value depends on the wavelength, phase and material):

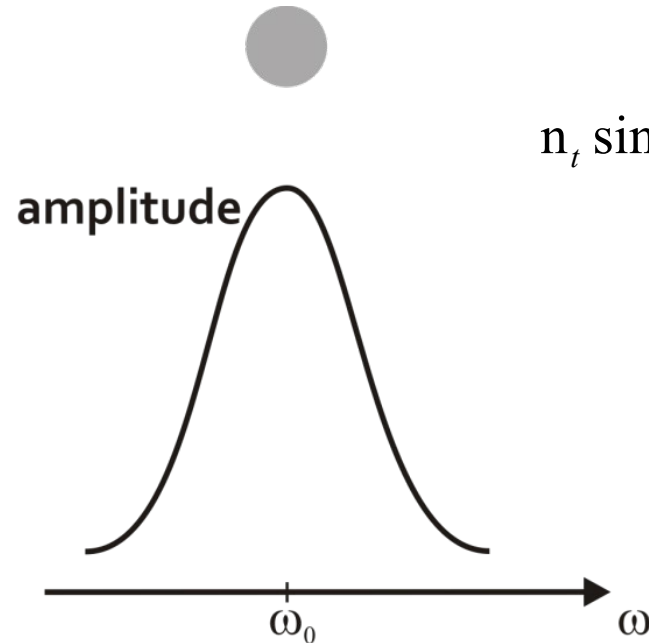

$$n_t \sin \theta_t - n_i \sin \theta_i = \frac{\lambda_0}{2\pi} \frac{d\Phi}{dx}$$

Generalized Snell's law

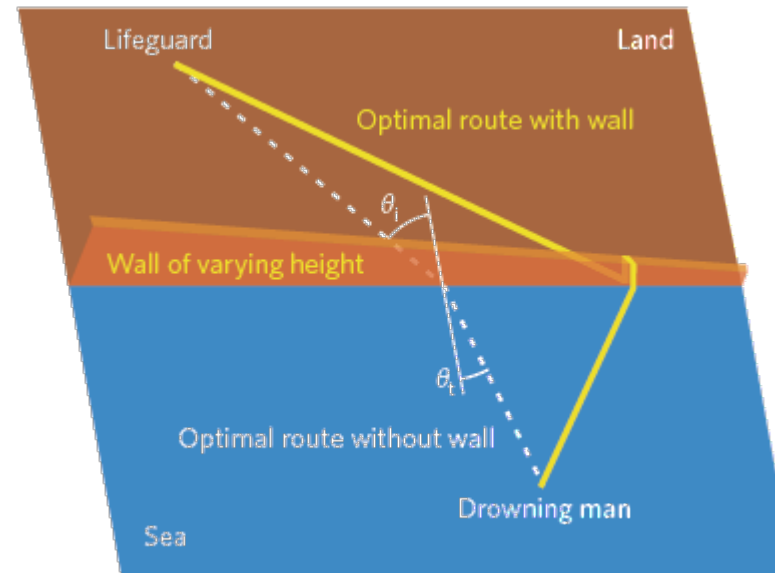

Science vol. 334, p. 333 (2011)

## Generalized Snell's law

- A plasmonic nanostructure also produces a phase shift (which value depends on the wavelength, phase and material):

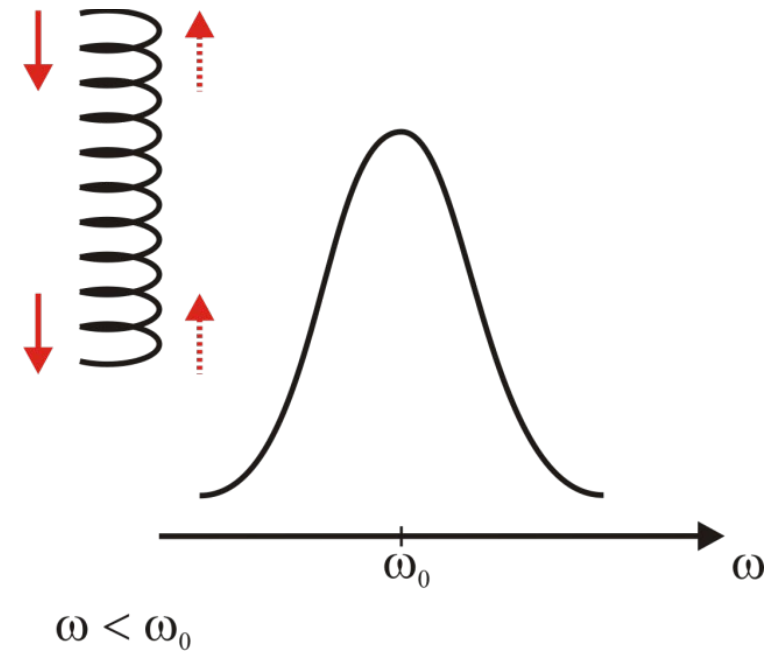
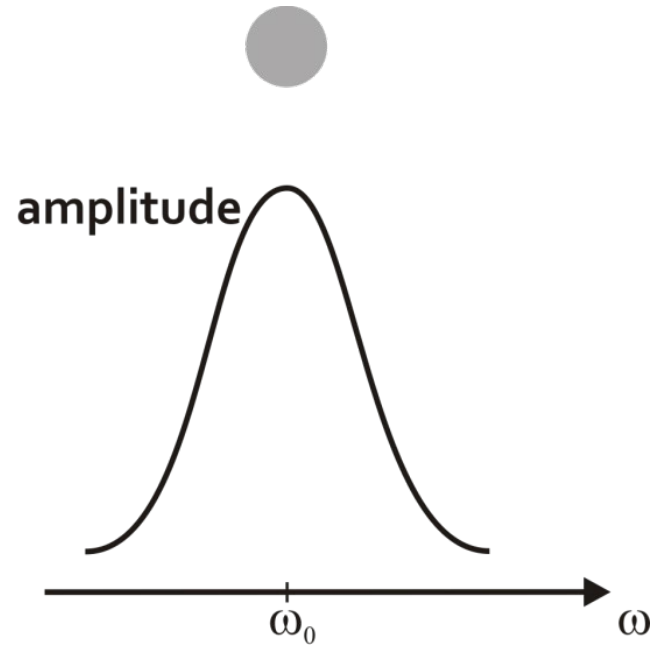

## Generalized Snell's law

- A plasmonic nanostructure also produces a phase shift (which value depends on the wavelength, phase and material):

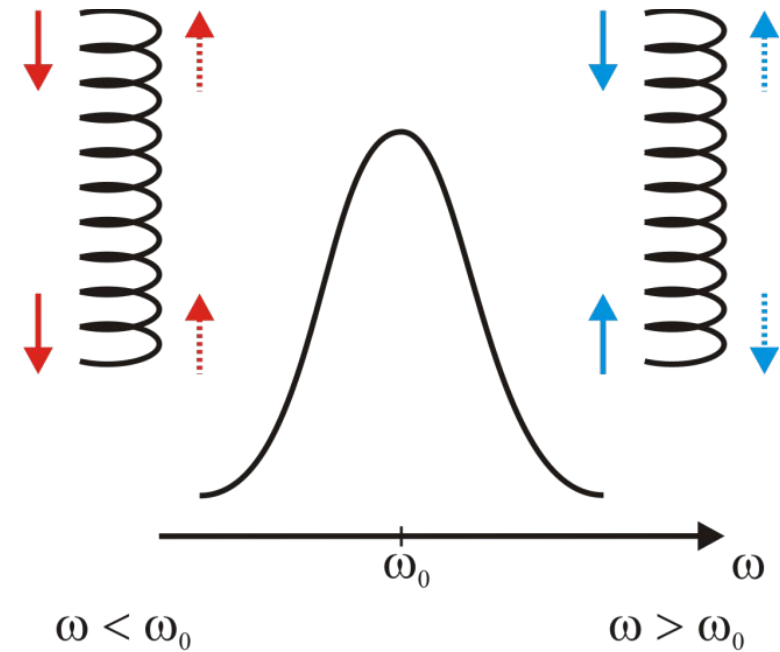
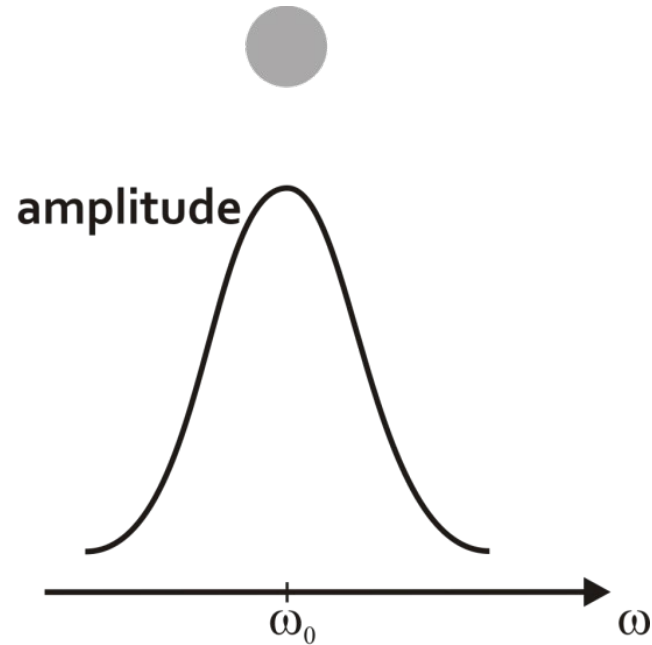

## Generalized Snell's law

- A plasmonic nanostructure also produces a phase shift (which value depends on the wavelength, phase and material):

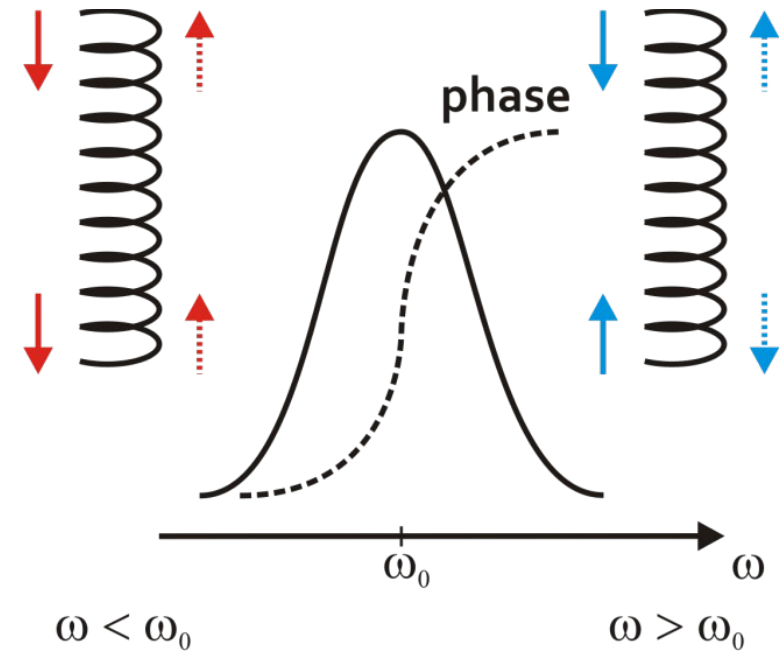
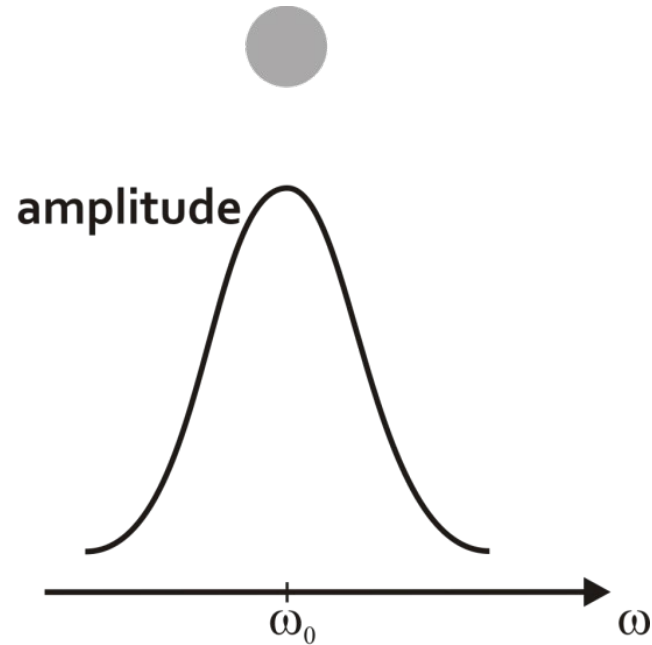

# Generalized Snell's law

- A plasmonic nanostructure also produces a phase shift (which value depends on the wavelength, phase and material):

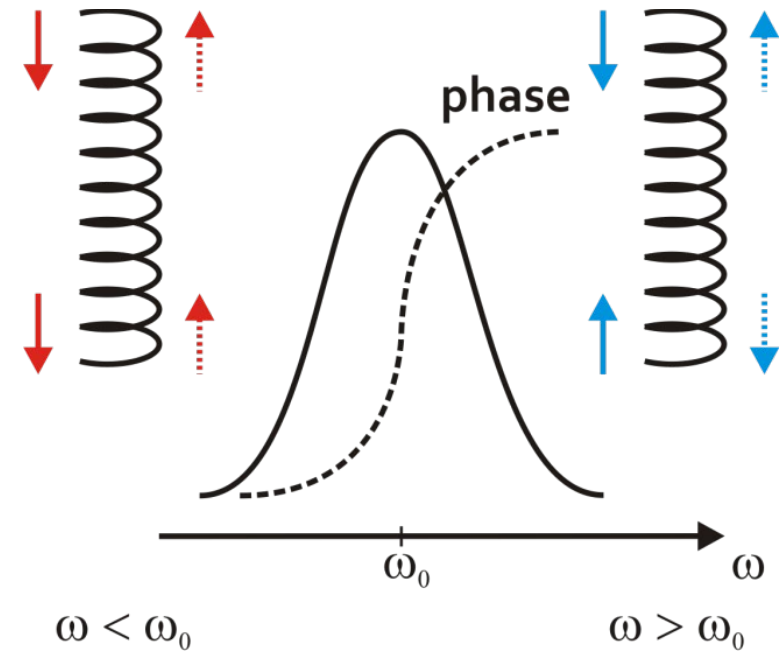
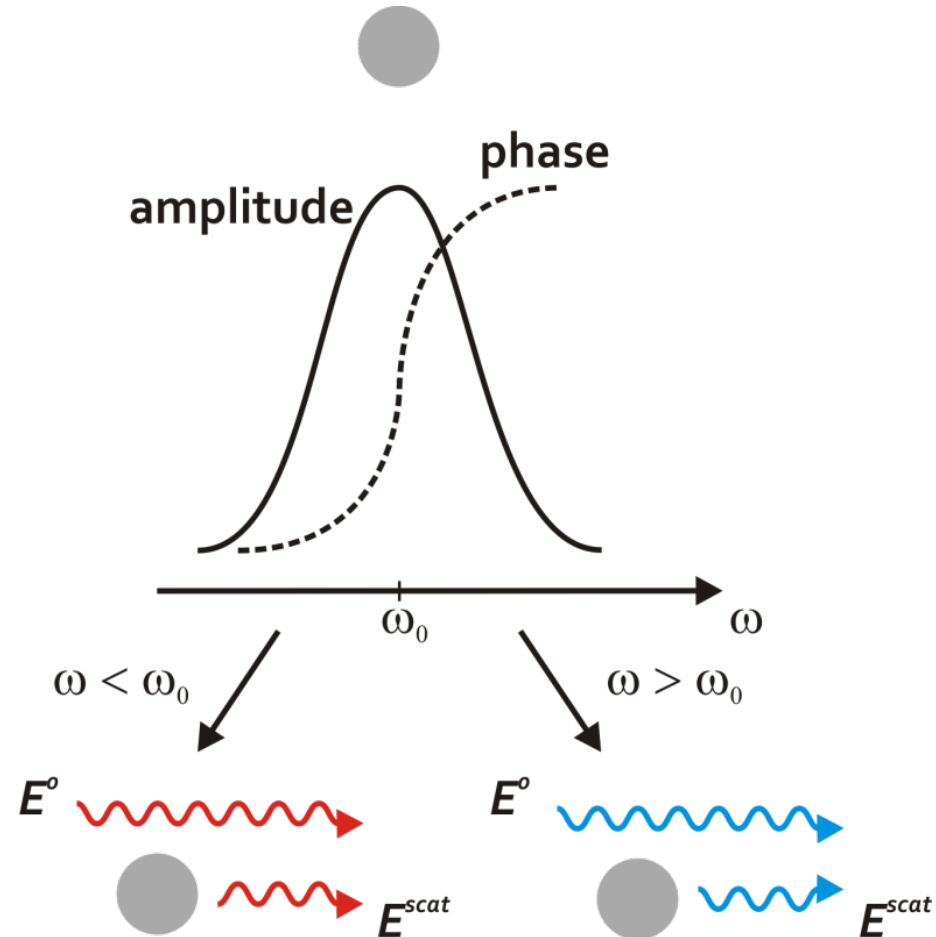

# All optical components manipulate the phase of light

- Grating:

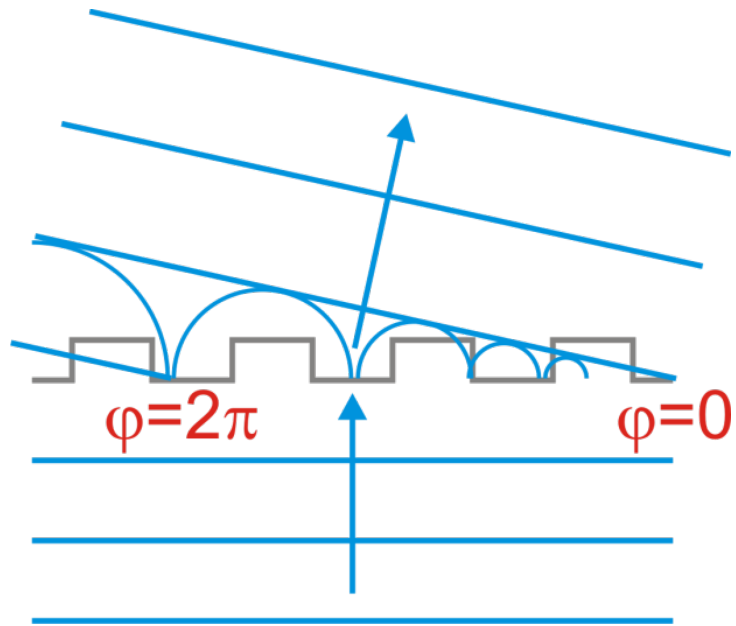

- Lens:

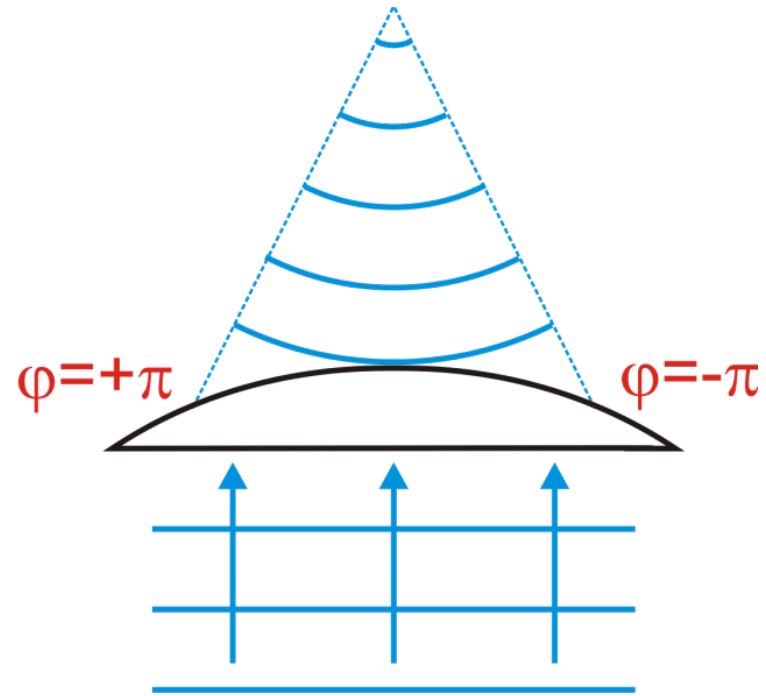

- Hologram:

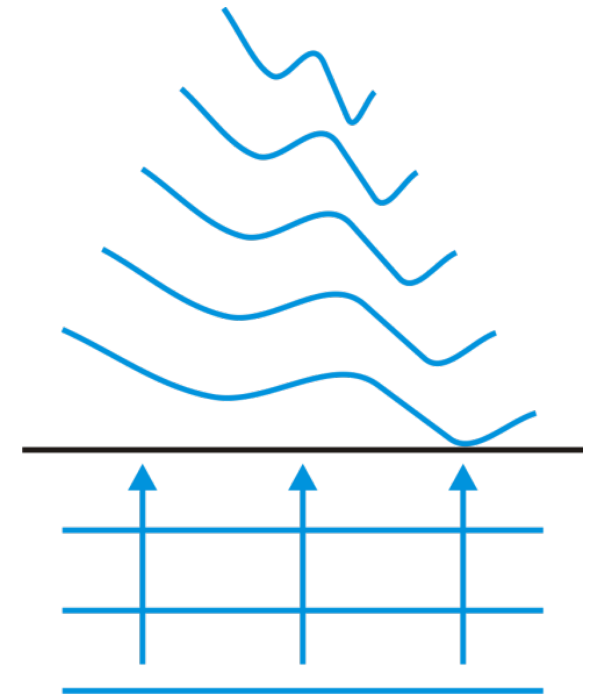

## Generalized Snell's law

- A plasmonic nanostructure also produces a phase shift (which value depends on the wavelength, phase and material):

$$n_t \sin \theta_t - n_i \sin \theta_i = \frac{\lambda_0}{2\pi} \frac{d\Phi}{dx} \quad \text{Generalized Snell's law}$$

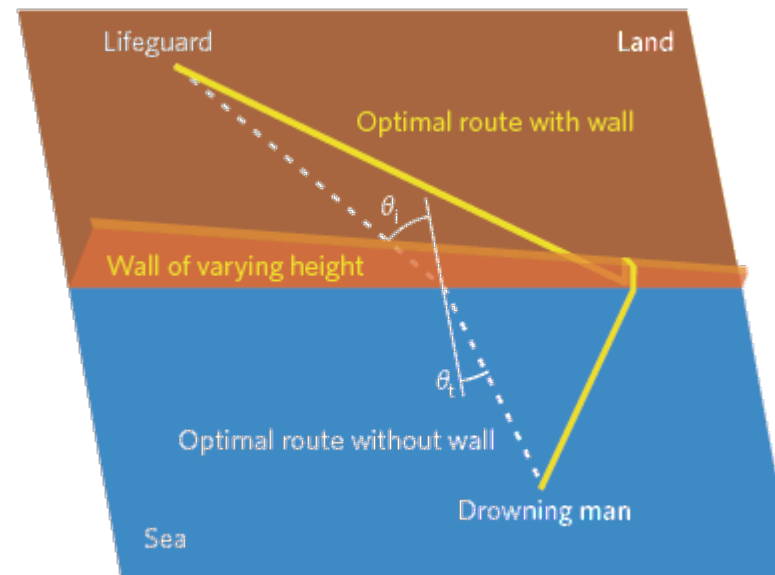
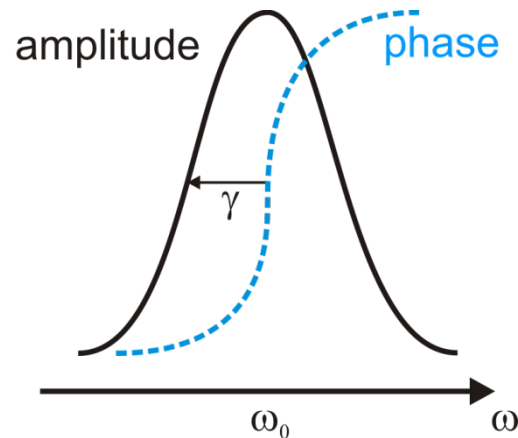

Science vol. 334, p. 333 (2011)

## Plasmon resonance – Phase control through the size

- Since particles with different sizes have plasmon resonances at different frequencies, the phase shift can be engineered by using different particle sizes

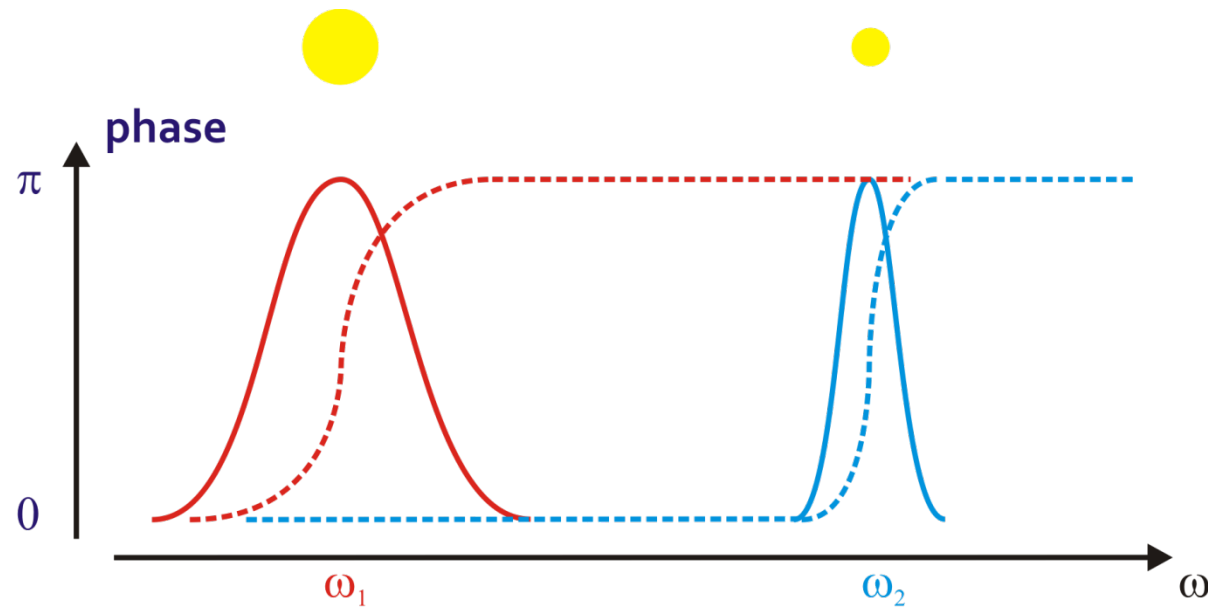

# Plasmon resonance – Phase control through the size

- Since particles with different sizes have plasmon resonances at different frequencies, the phase shift can be engineered by using different dimensions
- The amplitude should however remain as constant as possible

a.

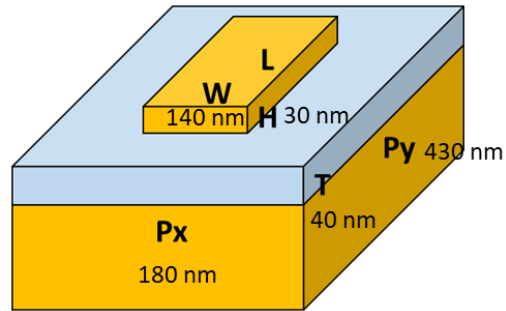

b.

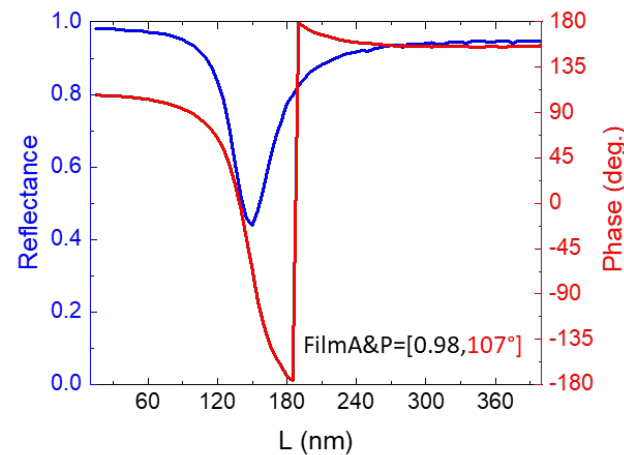

c.

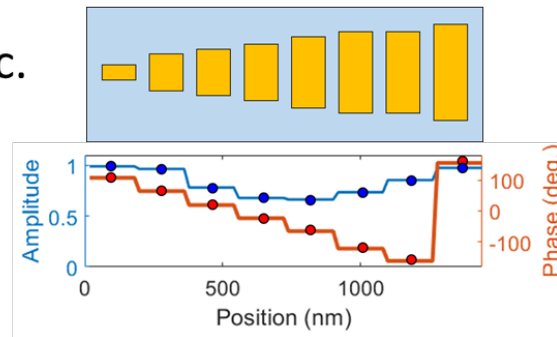

d.

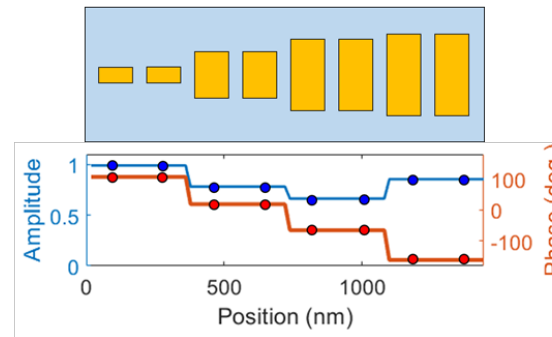

a.

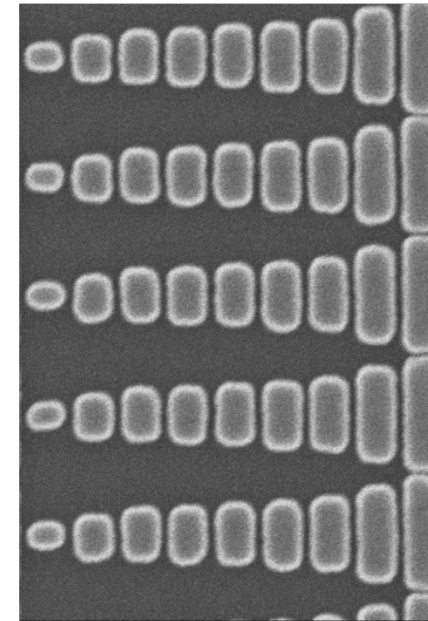

## Plasmon resonance – Phase control through the composition

- In the previous example, we controlled the phase through a change of shape
- It is also possible to control the phase through a change of material – here a change of stoichiometry in and Au-Ag alloy
- Only a few plasmonic metals exist and each works at a specific wavelength

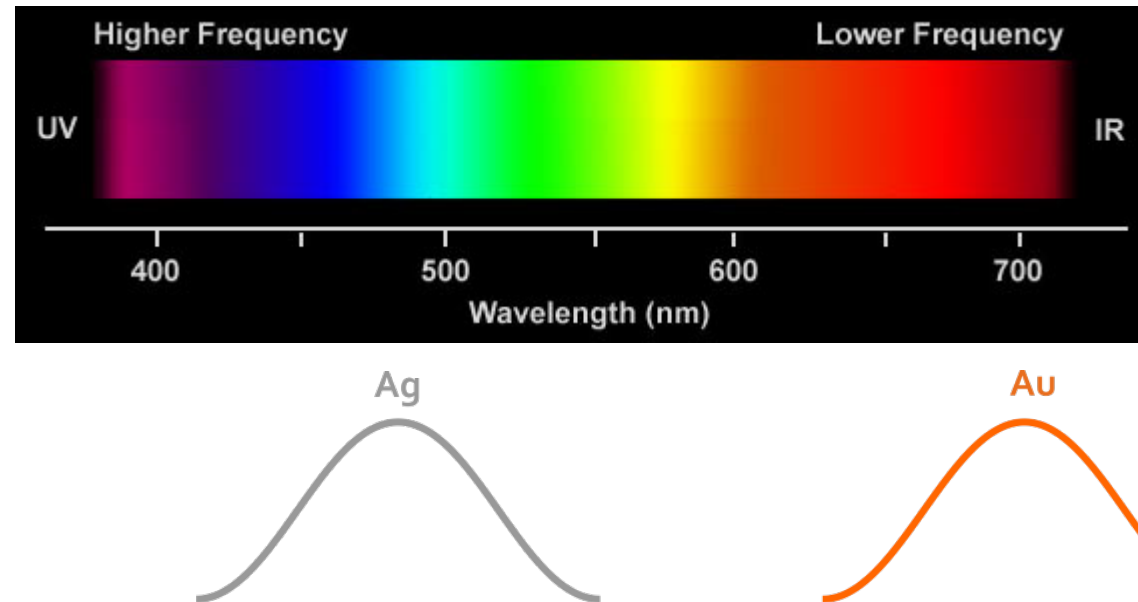

## Plasmon resonance – Phase control through the composition

- In the previous example, we controlled the phase through a change of shape
- It is also possible to control the phase through a change of material – here a change of stoichiometry in and Au-Ag alloy
- Only a few plasmonic metals exist and each works at a specific wavelength

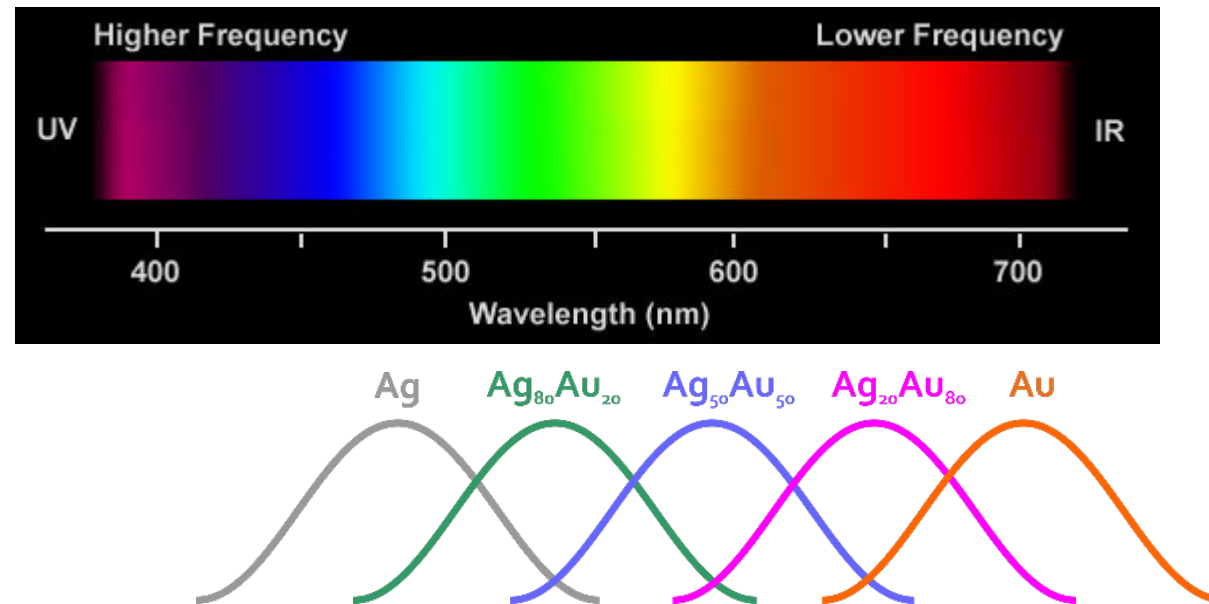

# Plasmonic alloys

- Continuous variation of the dielectric function vs. stoichiometry

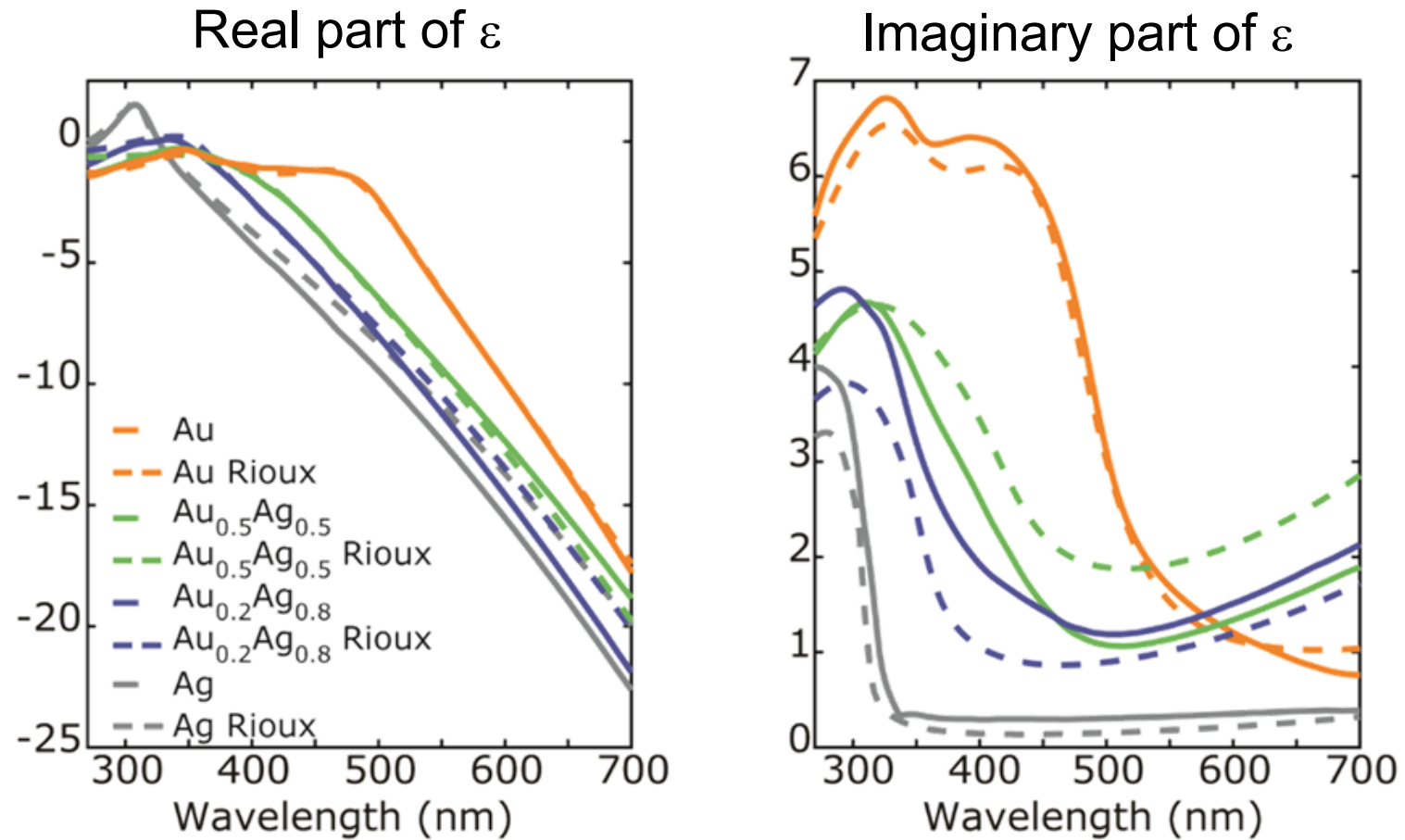

# Alloyed plasmonic nanostructures

- Normally,  $\text{Au}_x\text{Ag}_{1-x}$  alloying is performed at high temperature
- Can we maintain the shape of nanostructures during the alloying process...?

**Before annealing**

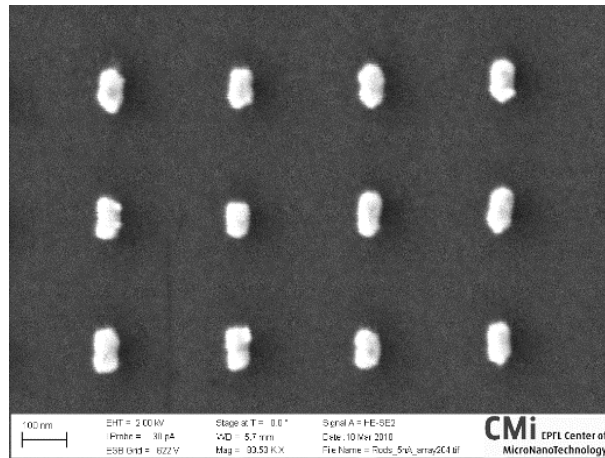

**After annealing**

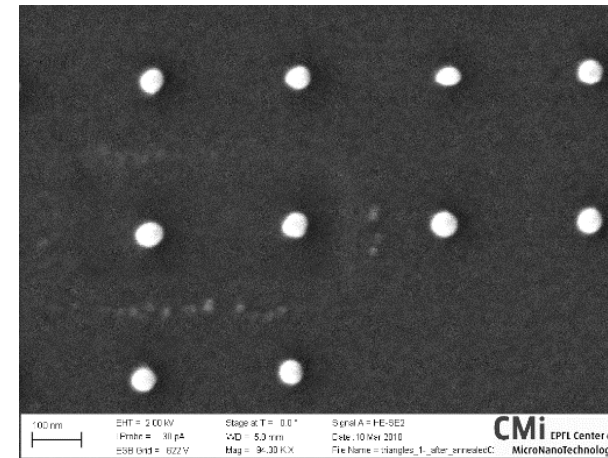

- ... no! the shape is lost during the high temperature annealing

# Alloyed plasmonic nanostructures

- Challenge:
  - Find a low temperature alloying procedure...
  - ... that enables any alloy composition
- Solution:
  - Define the composition by the Au and Ag thicknesses
  - Alloy at 300°C for 8 hours and 450°C for 30 mins

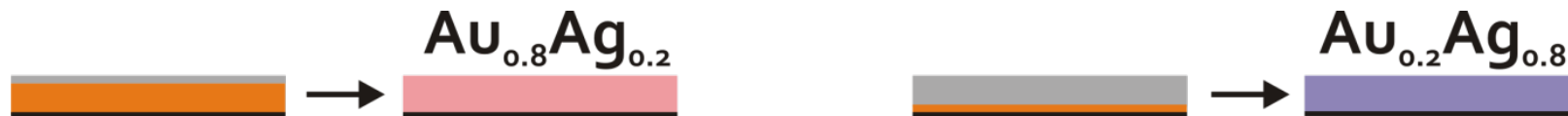

# Alloyed plasmonic nanostructures

- A low temperature annealing process can maintain the particle shape, whilst producing well alloyed materials

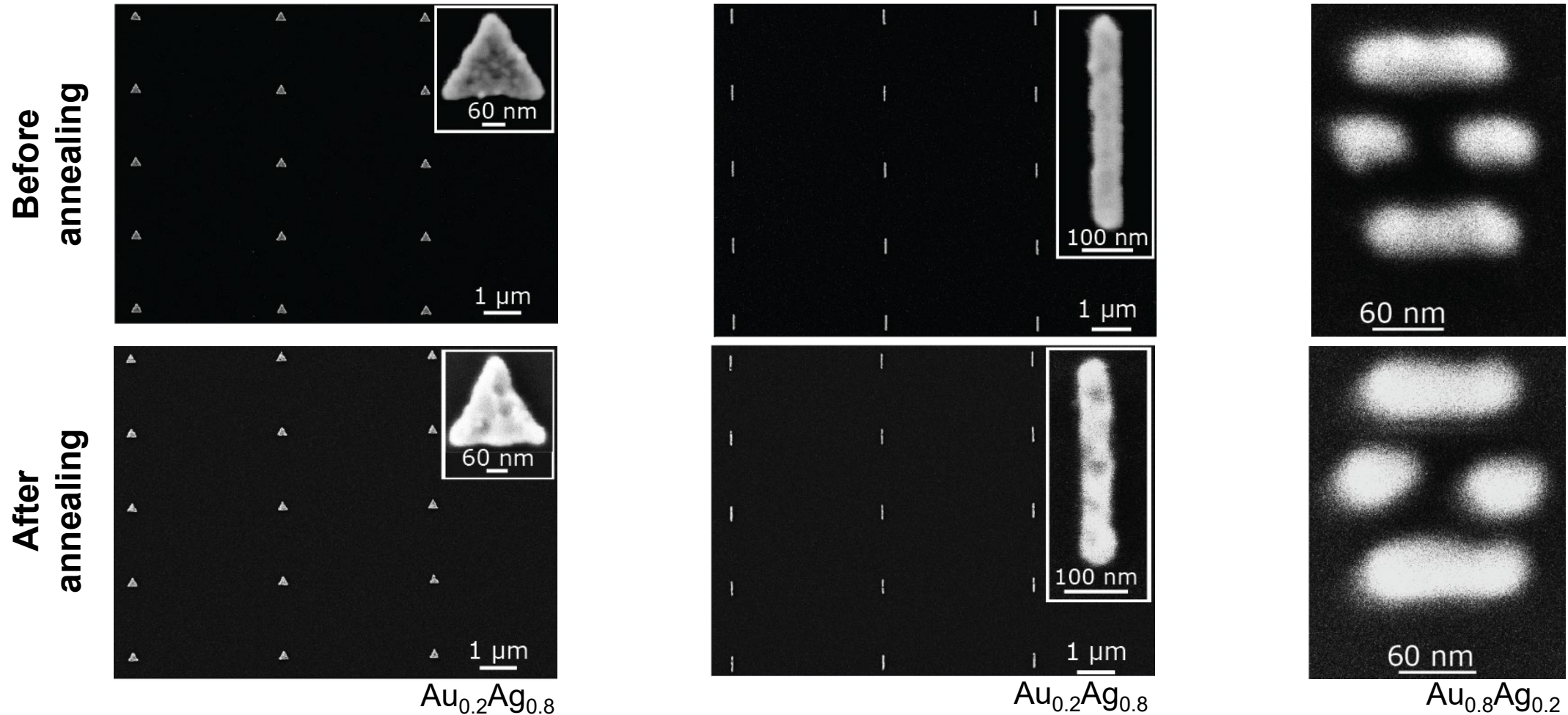

# Alloyed plasmonic nanostructures

- Well alloyed materials (EDX and XPS)

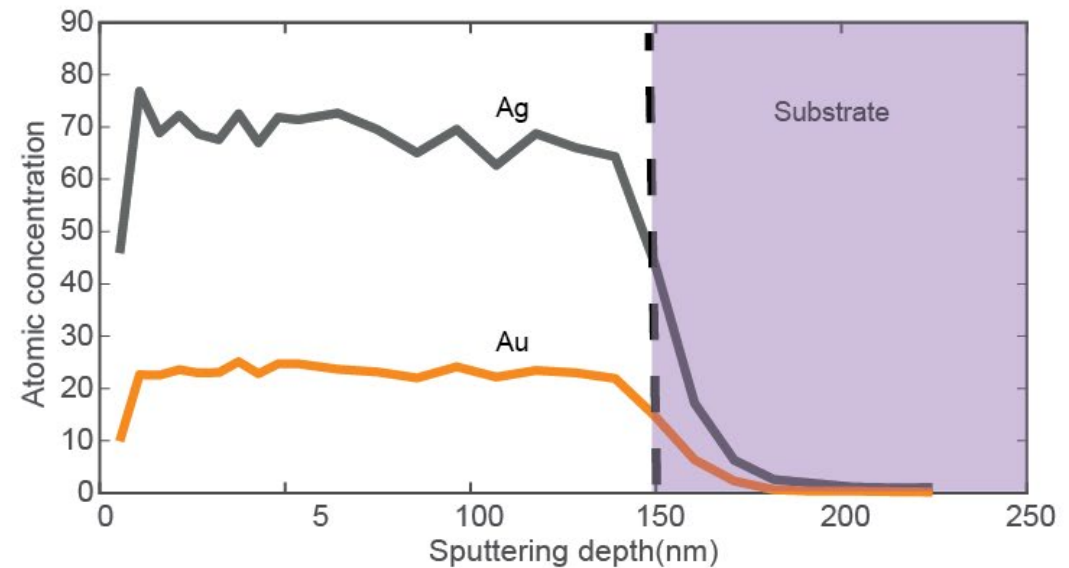
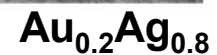
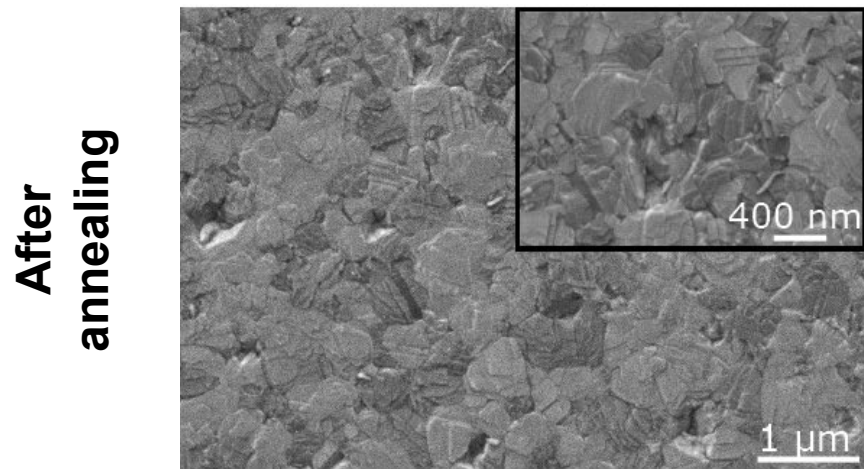
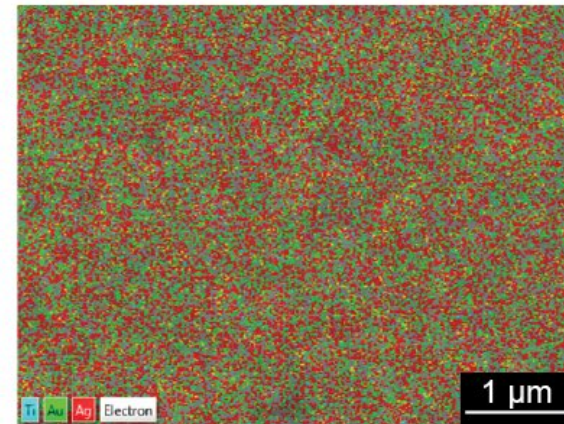
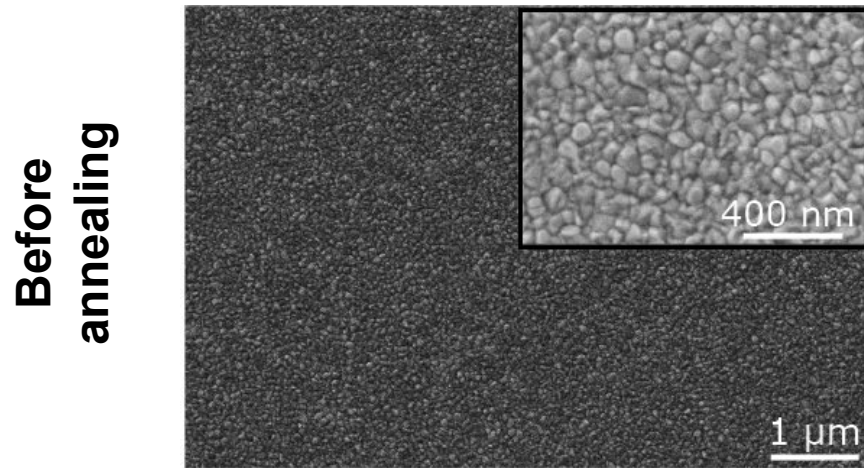

# Plasmonic metasurfaces

- Instead of using different geometries, we can use the same geometry and change the stoichiometry to obtain different phases on the metasurface:

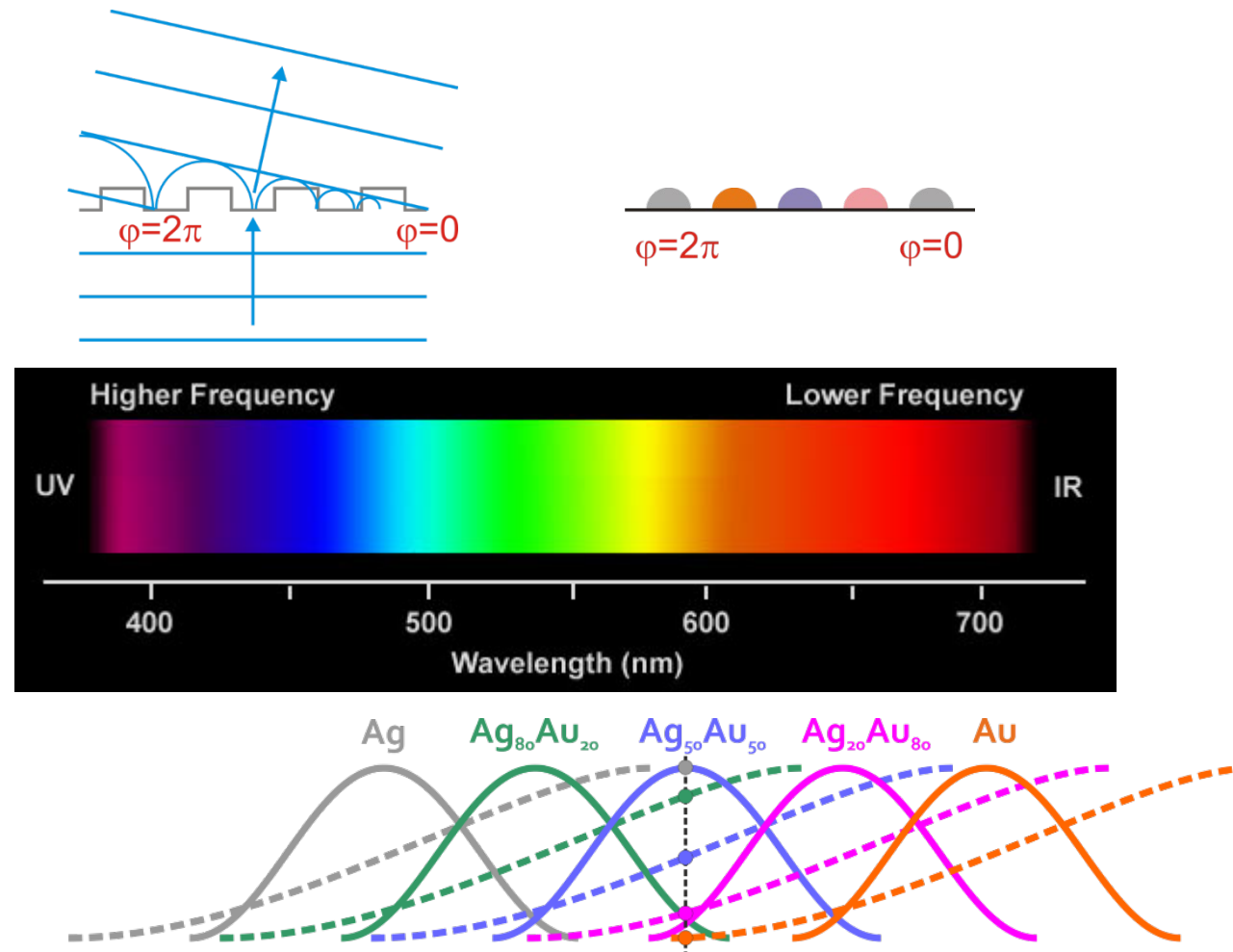

# Alloyed plasmonic metasurfaces

- Combinations of different alloy compositions on the same sample to produce more complex optical effects

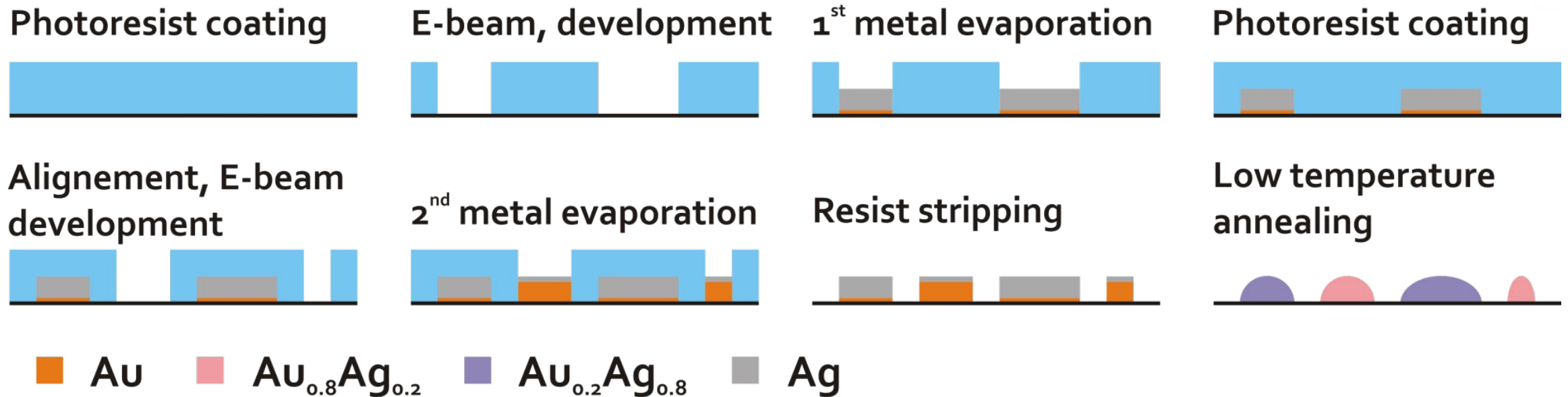

1  $\mu\text{m}$



200 nm

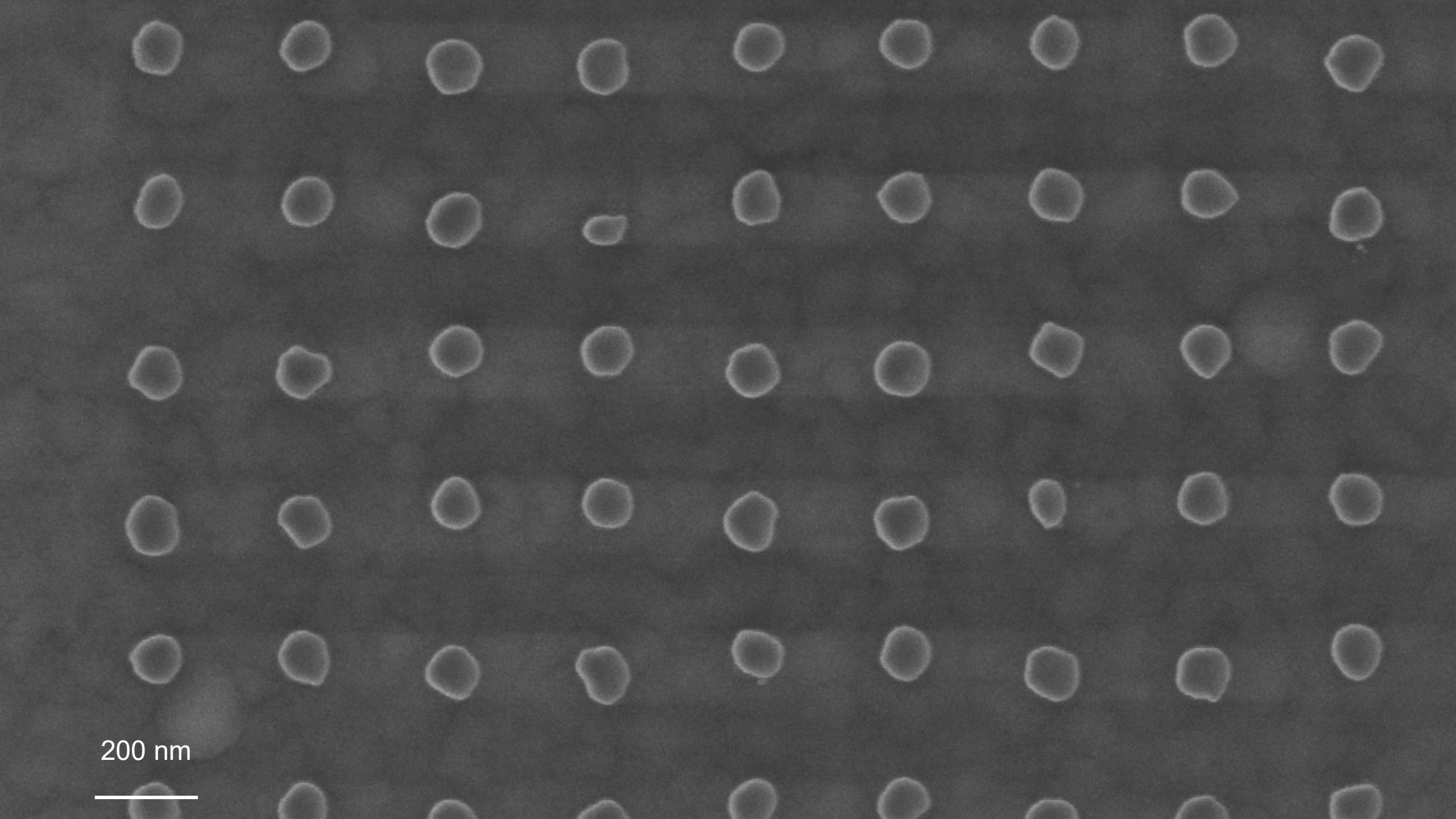

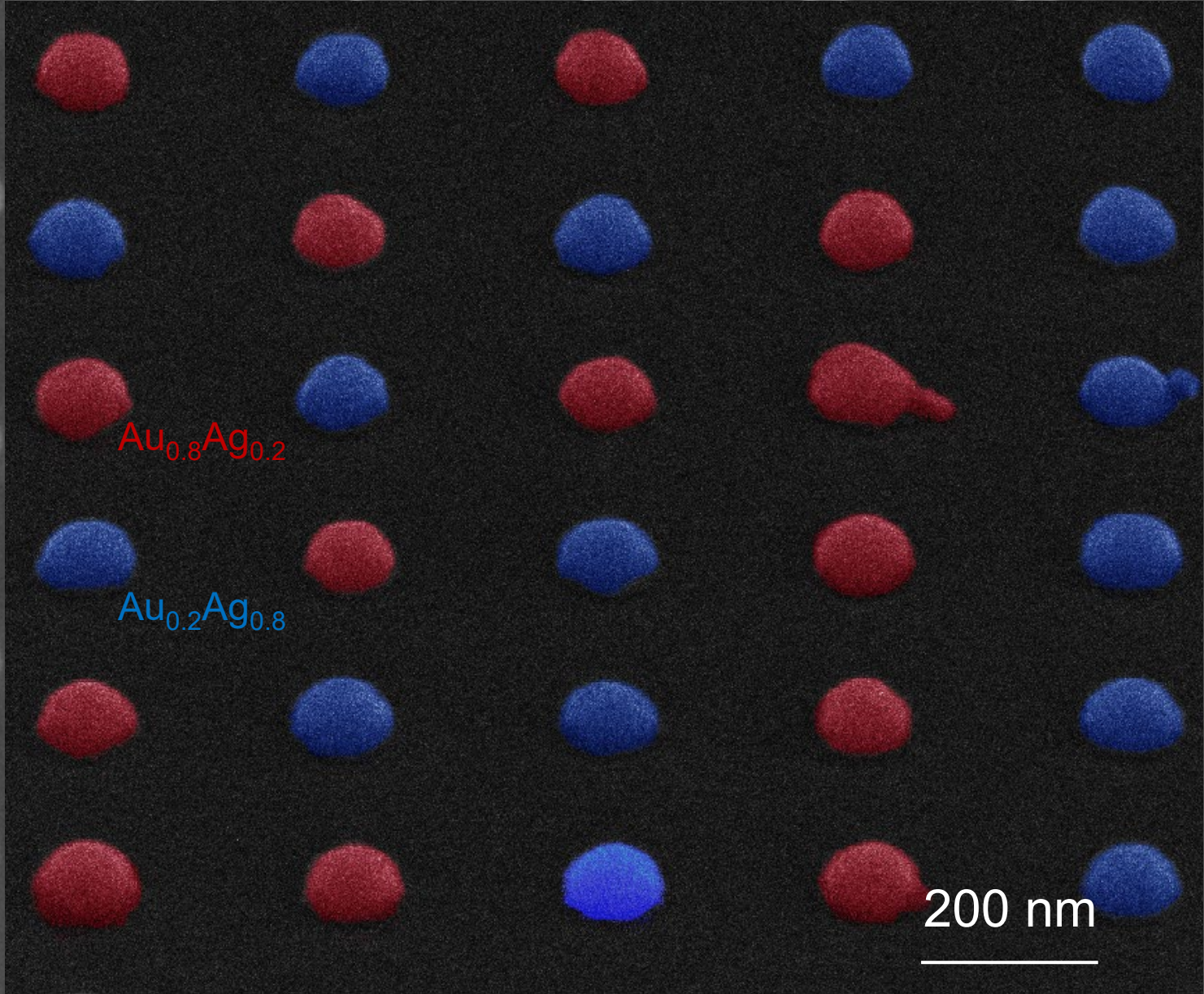

# Complex metasurfaces

- Hologram:



$\lambda=532$  nm

- Lens:

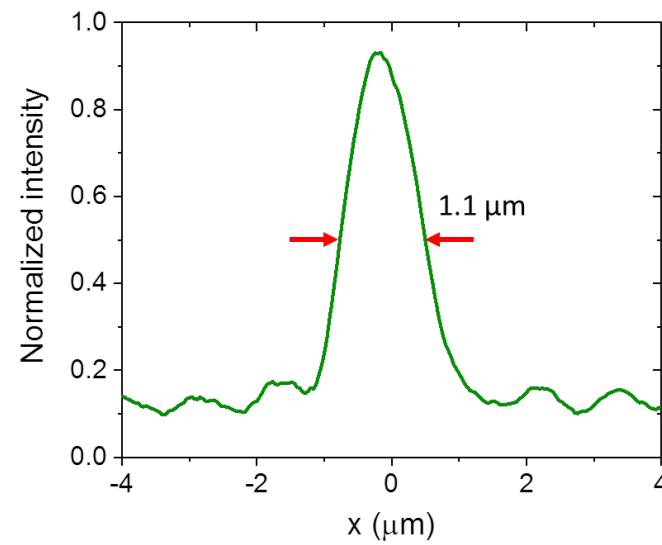
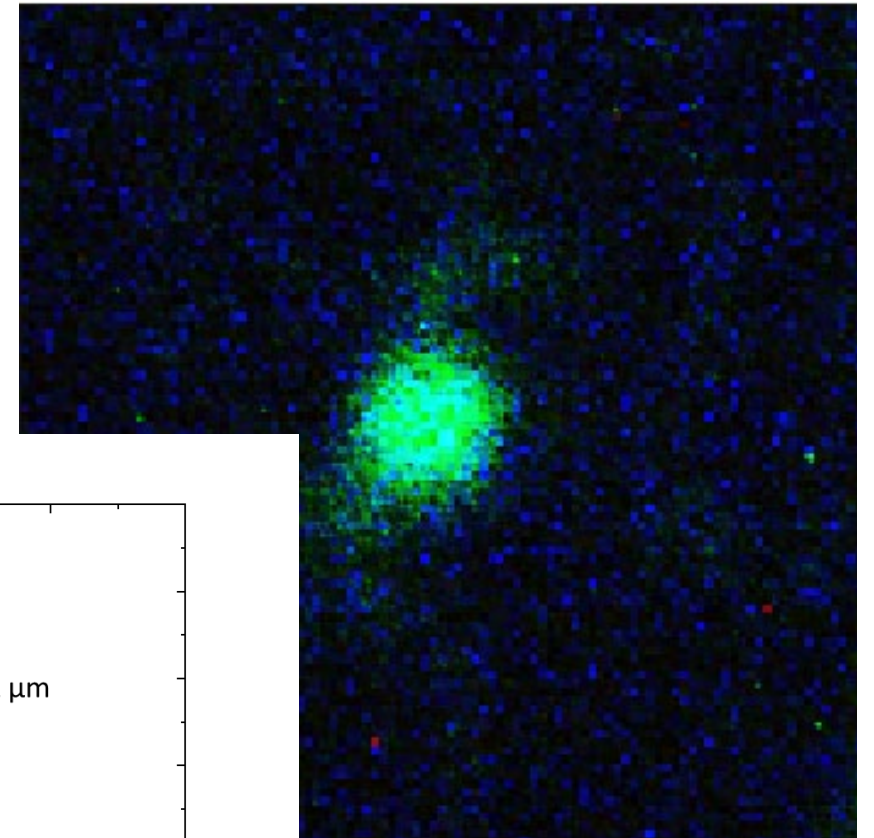

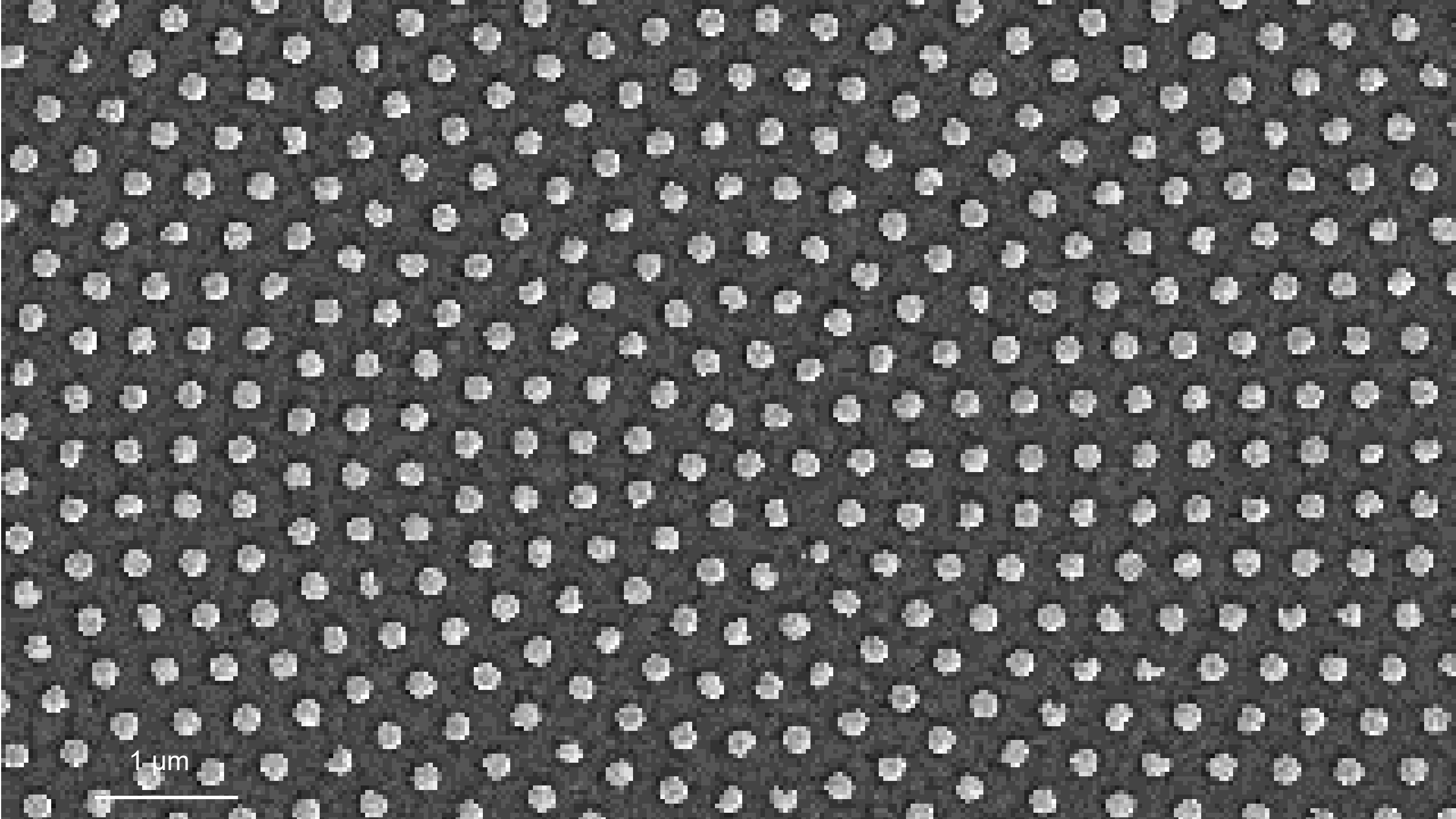

# Selected Topics in Advanced Optics

---

## Week 12 – part 2

Olivier J.F. Martin  
Nanophotonics and Metrology Laboratory

**EPFL**

# Generalized Snell's law – Anomalous reflection

- The engineering of the phase is arbitrary in those systems
- Each structure produces a different phase shift

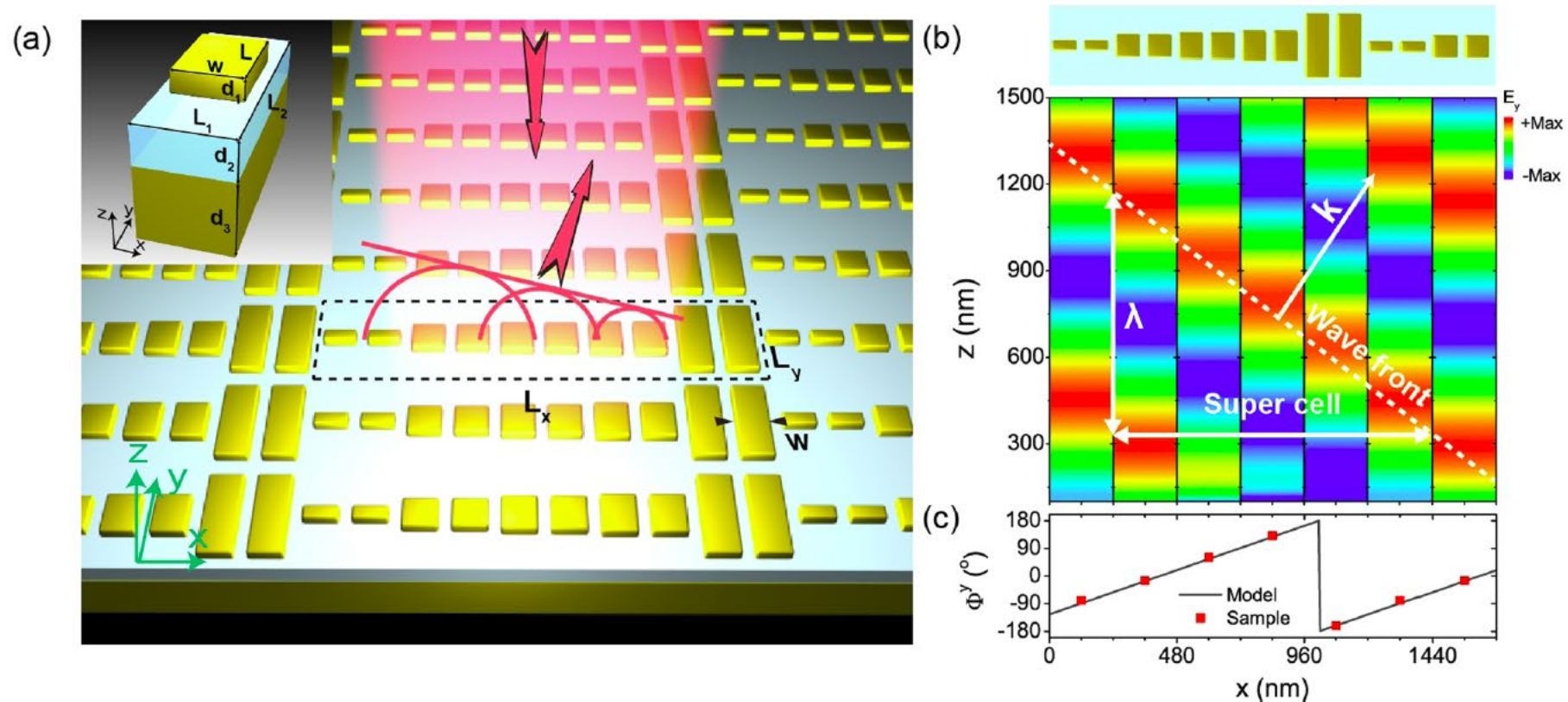

S. Sun, Nano Letters vol. 12, p. 6223 (2012)

# Generalized Snell's law – Anomalous reflection

- The engineering of the phase is arbitrary in those systems
- Each structure produces a different phase shift

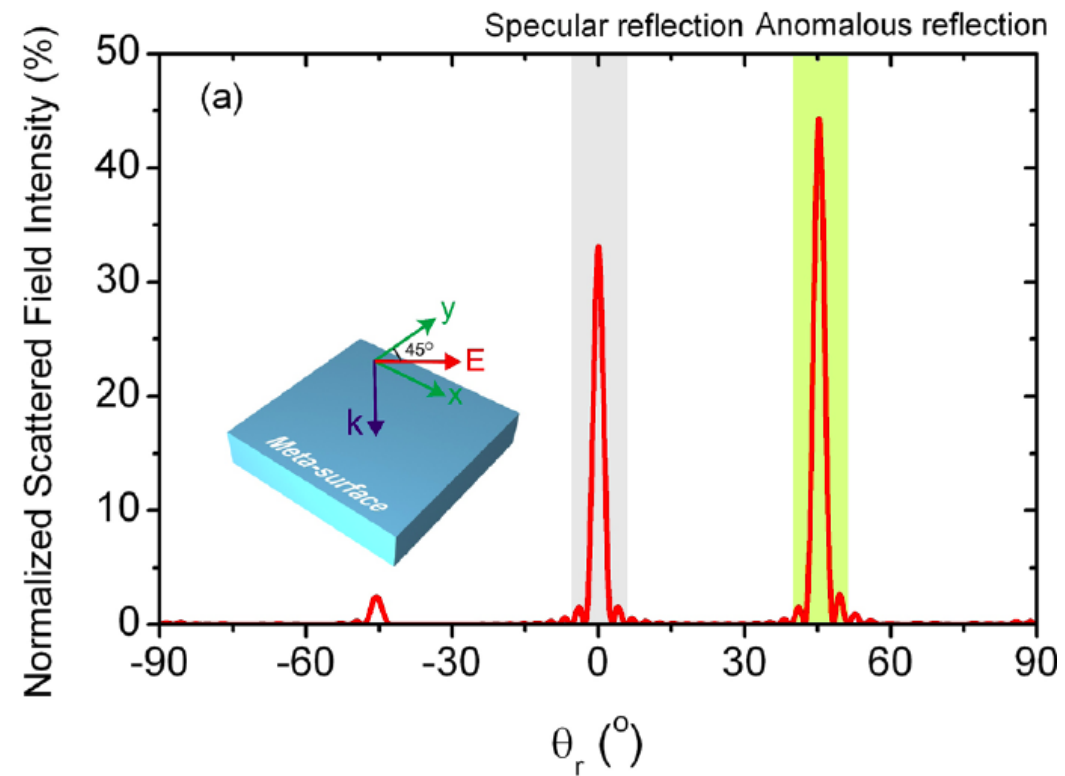
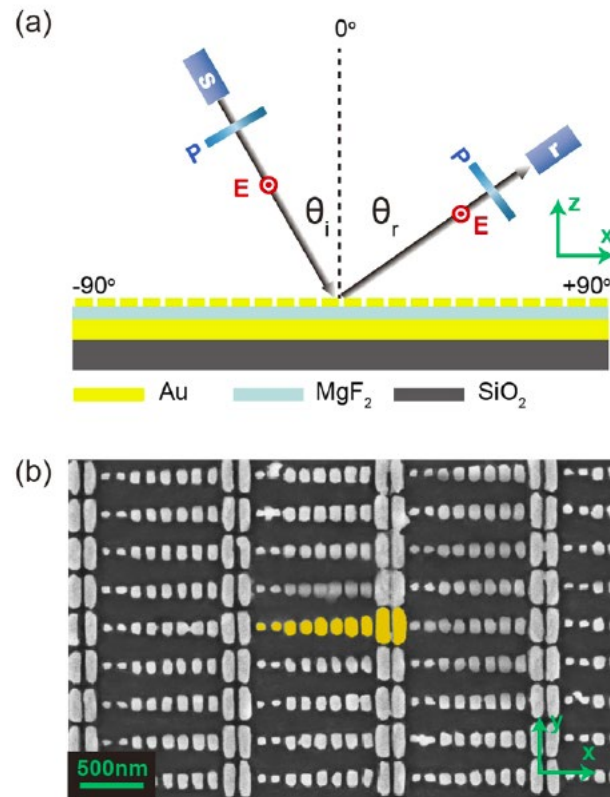

S. Sun, Nano Letters vol. 12, p. 6223 (2012)

# Blazed grating

- One should not forget classical optics, which remains a fantastic source of inspiration!

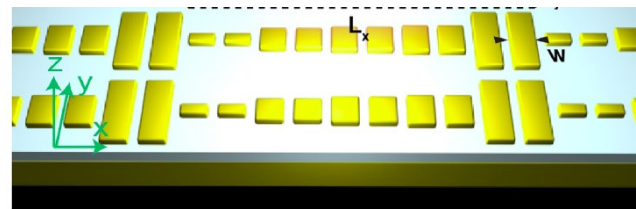
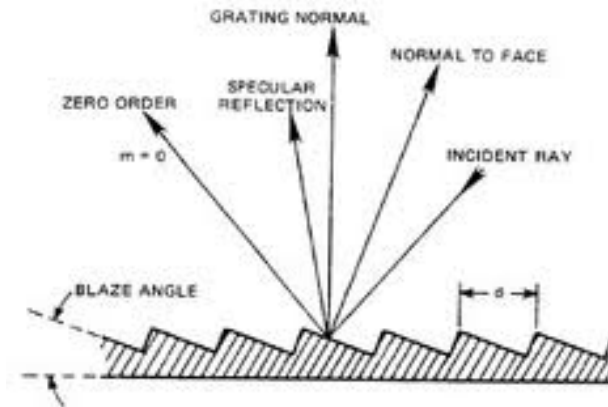
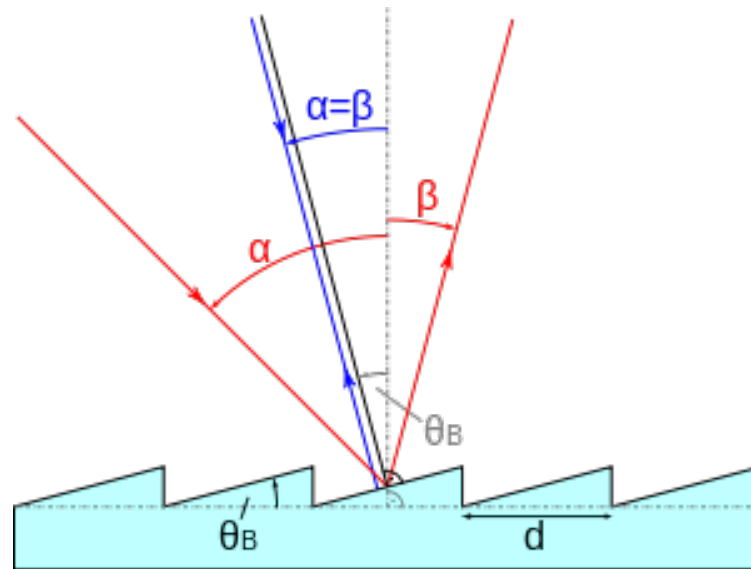

# Generalized Snell's law

- A plasmonic V-shaped nanostructure can introduce a phase in the scattered wave, which originates from the interplay between the two modes that can be excited in the structure

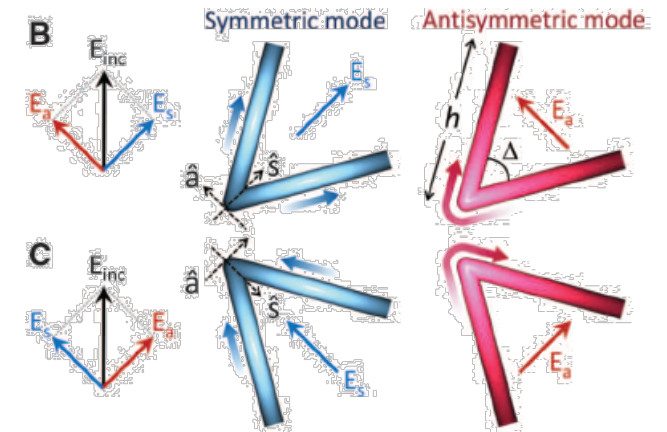
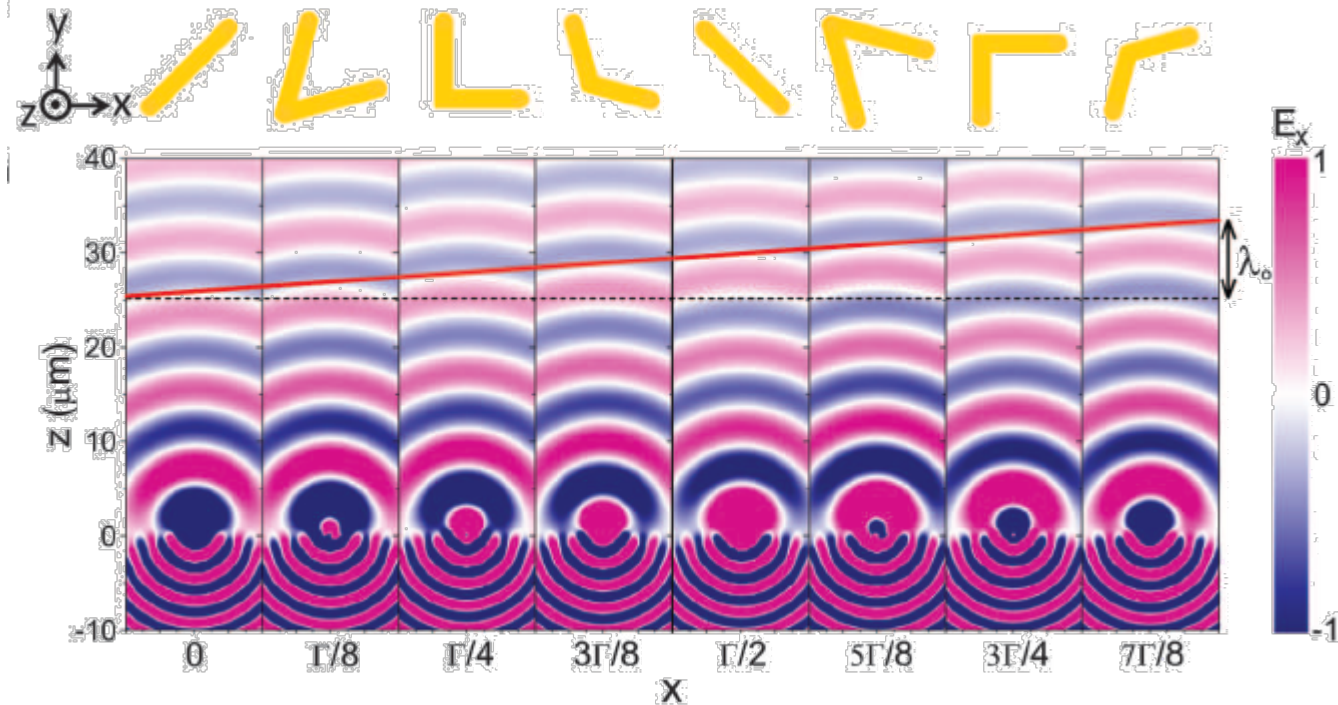

Science vol. 334, p. 333 (2011)

# Generalized Snell's law – Negative refraction can be produced this way

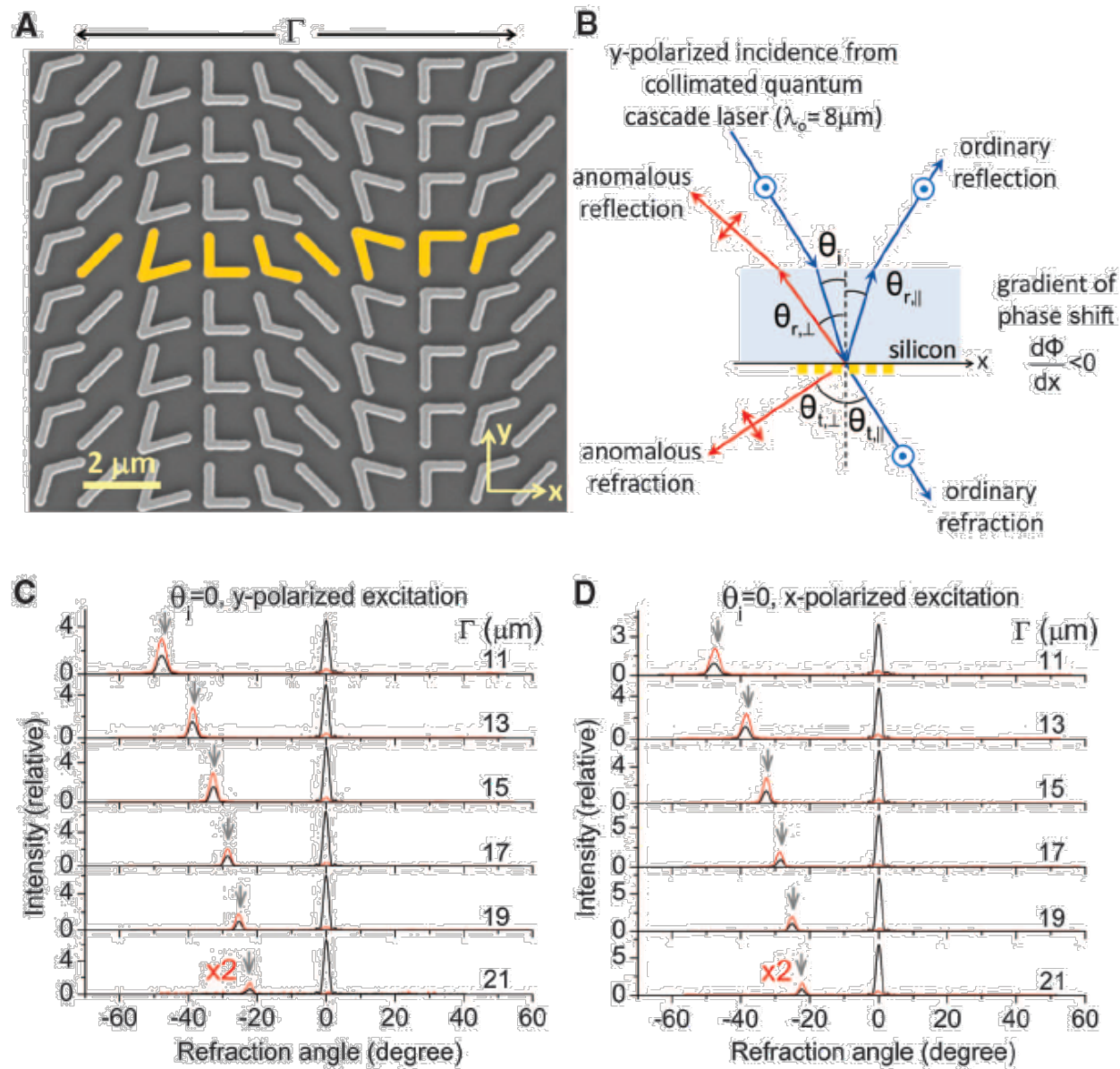

## Extending the phase beyond $\pi$

- Normally, any optical resonance is associated with a phase shift of  $\pi$ . To produce a metasurface, we need a phase shift of  $2\pi$
- This can be achieved with a mirror under the nanostructures

Fresnel coefficients for external reflection ( $n_1 < n_2$ , TE):

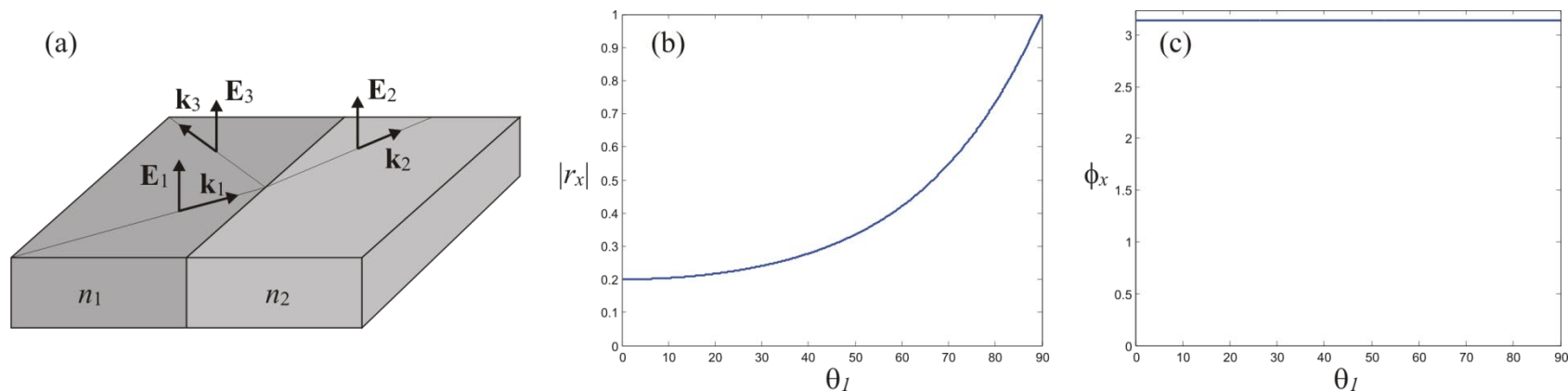

# Extending the phase beyond $\pi$

Without a surface:

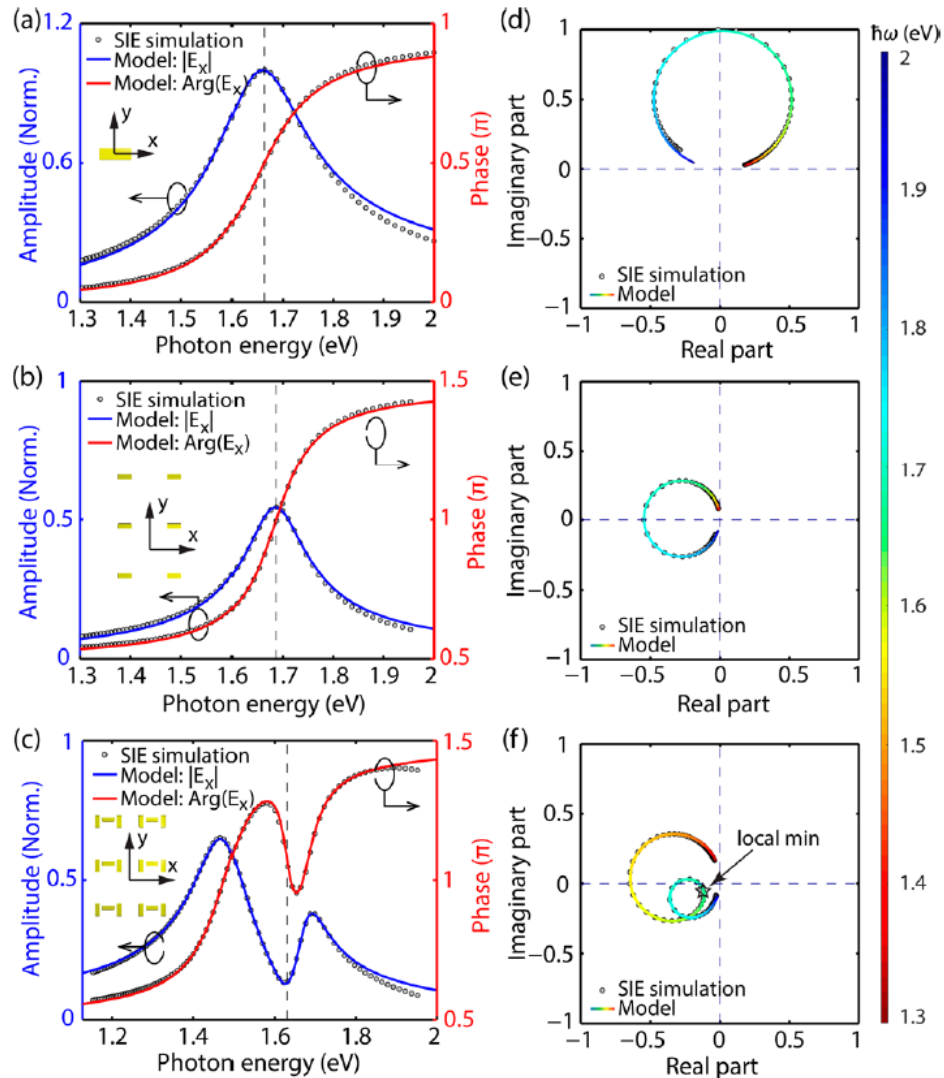

With a surface/mirror:

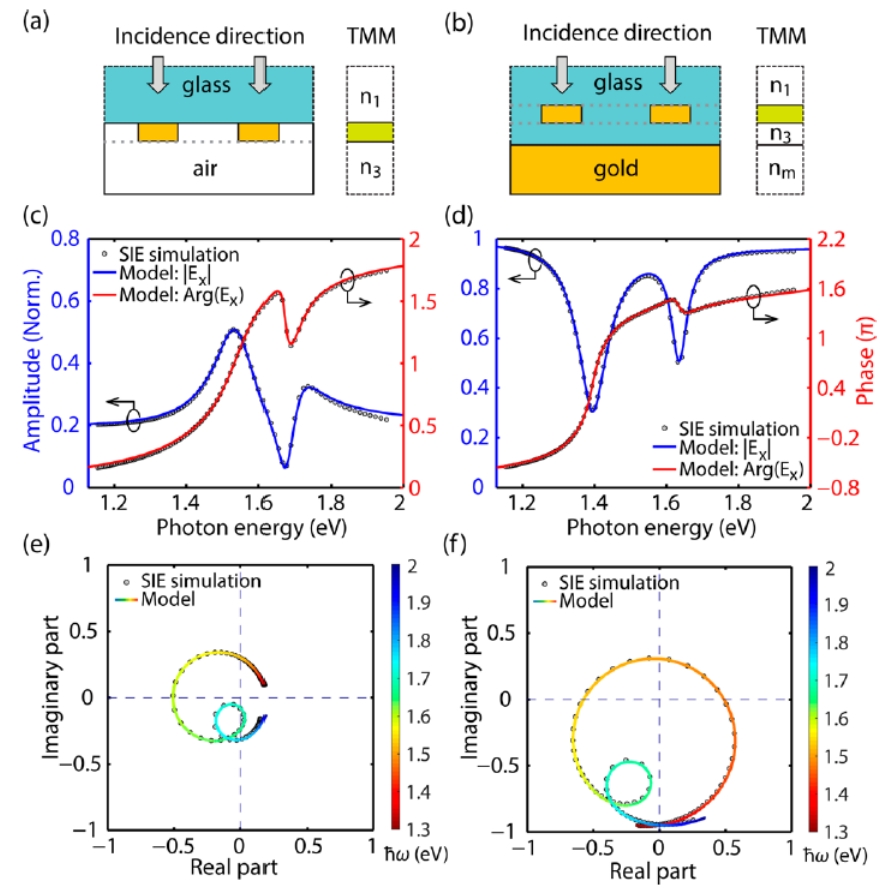

# Selected Topics in Advanced Optics

---

## Week 12 – part 3

Olivier J.F. Martin  
Nanophotonics and Metrology Laboratory

**EPFL**

# Designing a hologram with meta-atoms

- Monochromatic object wave  $U_o(x, y)$
- Its complex amplitude is recorded by performing an interference with a reference wave:

wave:

$$t \propto |U_o + U_r|^2 = |U_r|^2 + |U_o|^2 + U_r^* U_o + U_r U_o^* = I_r + I_o + U_r^* U_o + U_r U_o^* .$$

- The hologram is reconstructed with the same reference wave:

$$U = U_r t \propto U_r I_r + U_r I_o + I_r U_o + U_r^2 U_o^* .$$

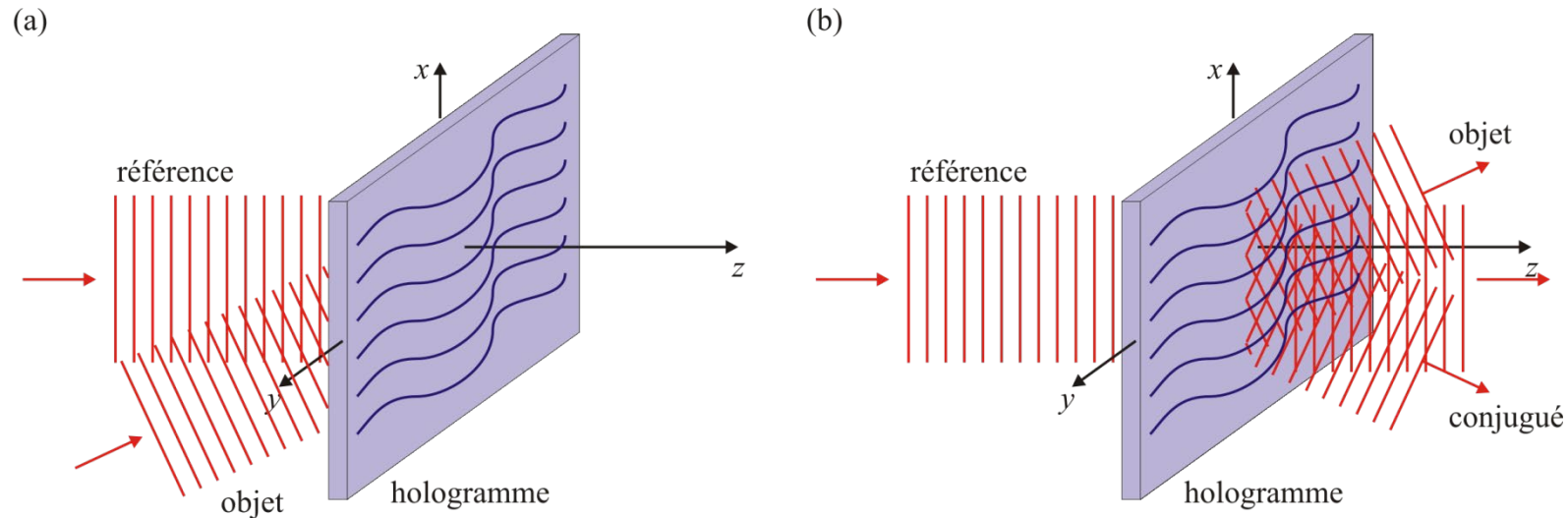

# Designing a hologram with meta-atoms

- A hologram encrypts the amplitude and phase of an object by recording its interference with a reference wave

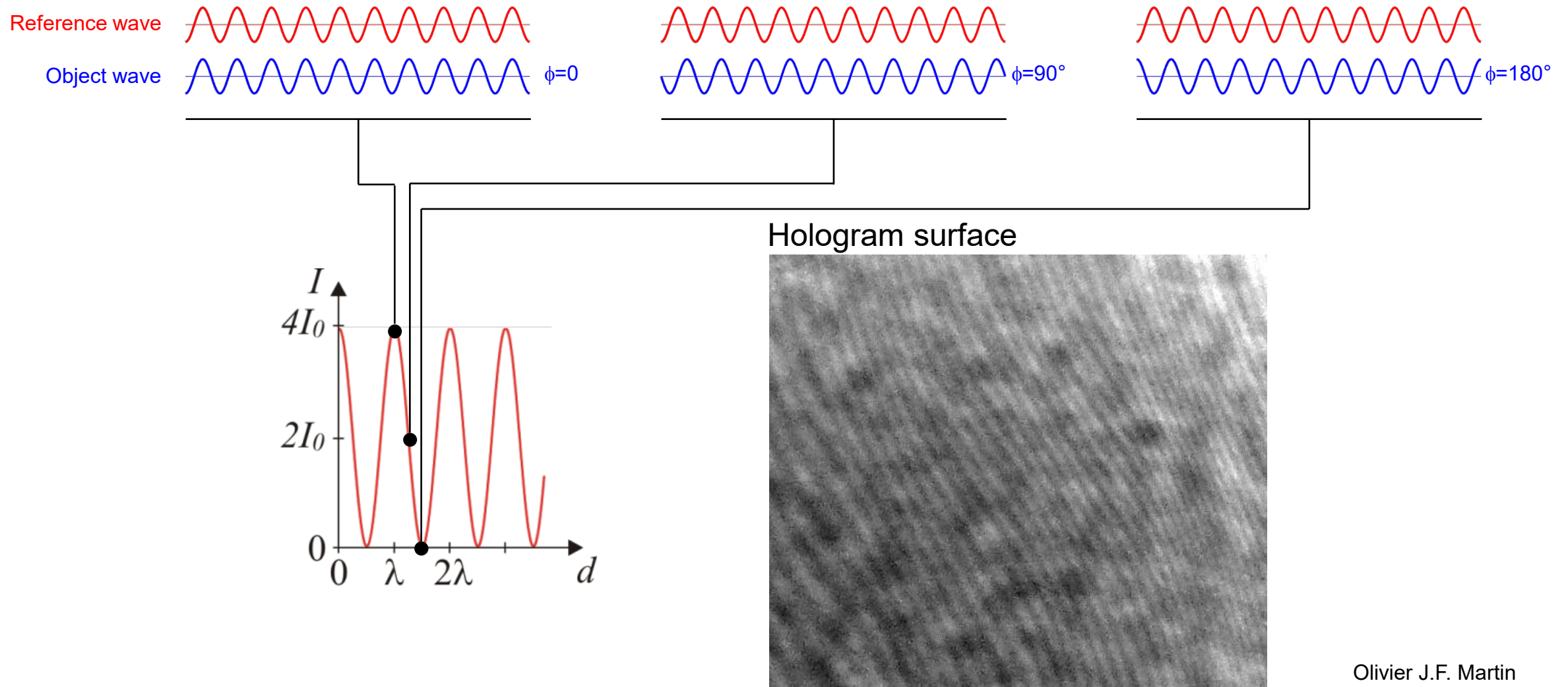

# Meta-hologram design

- The phase distribution on the hologram surface is discretized with nanostructures that produce different phases
- Only the phase is usually discretized (although one could also discretize the amplitude)
- For example nanorods with different lengths produce different phases with an almost constant reflectance

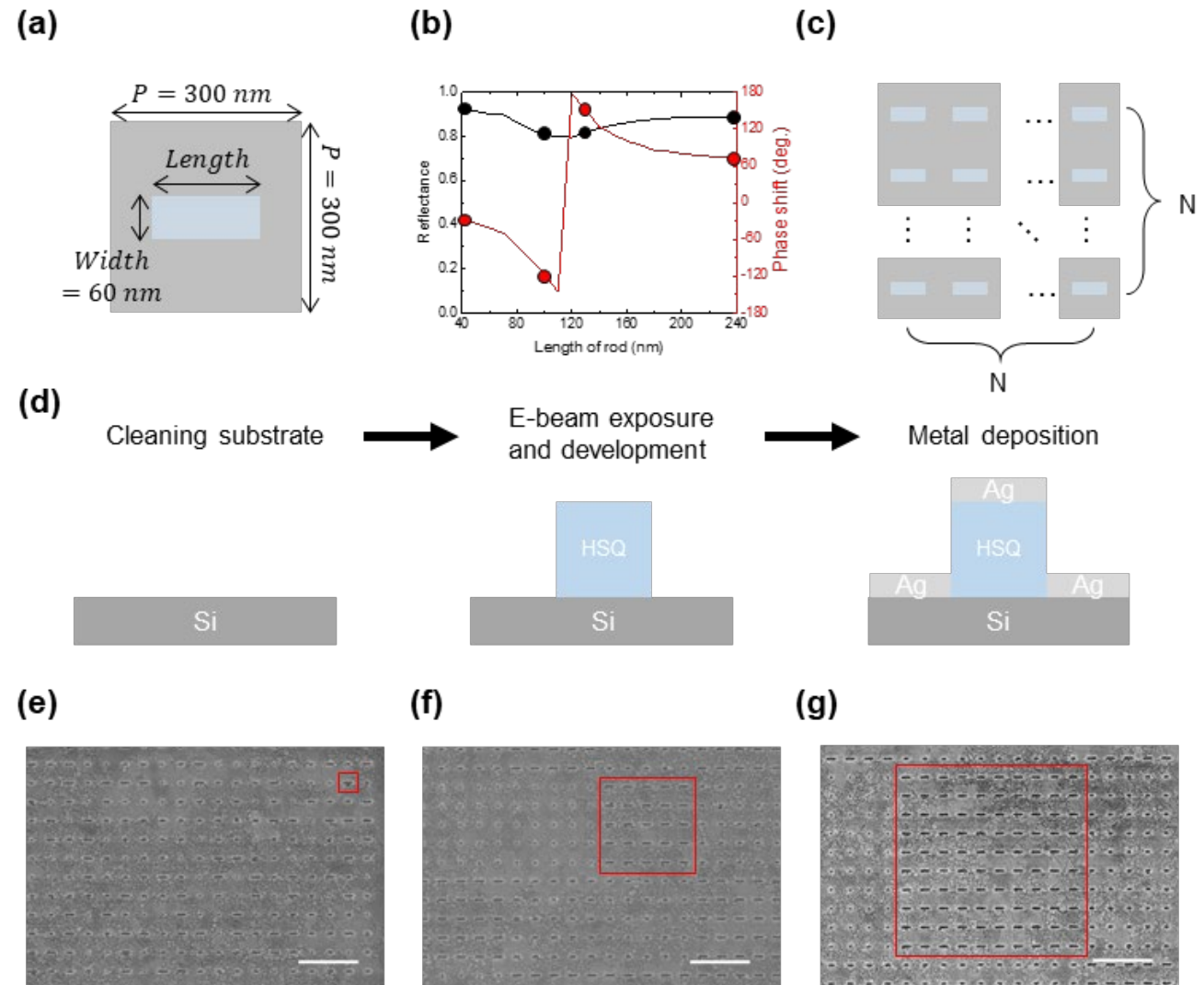

# Meta-hologram design

- An iterative procedure is used to obtain the target image by only adjusting the phase
- As the iterations progress, the hologram image appears more clearly

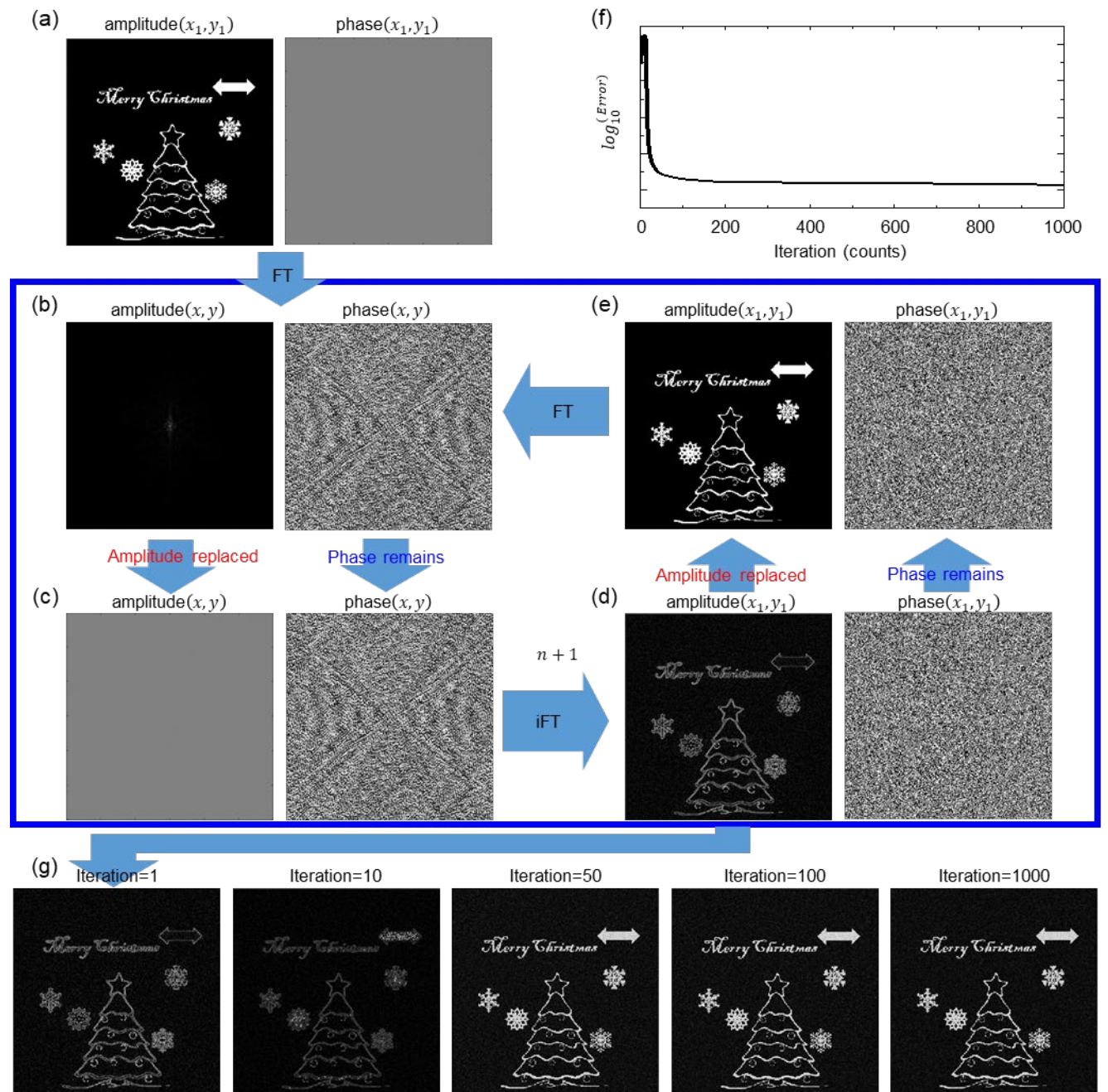

## Meta-hologram design

- The hologram efficiency depends on the number of discrete phases (levels) used to reproduce the image
- Some spurious effects can occur when only 2-levels are used

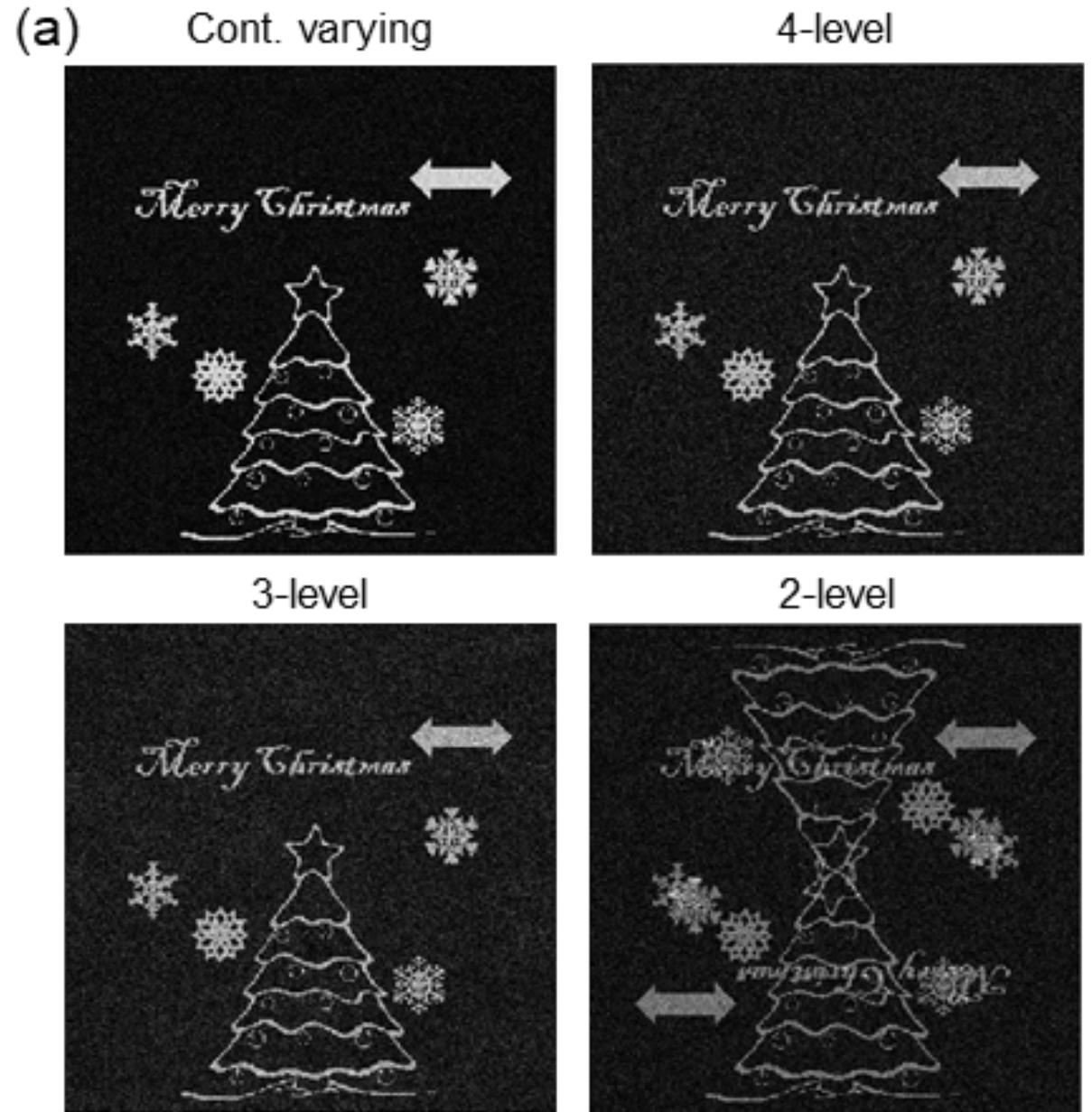
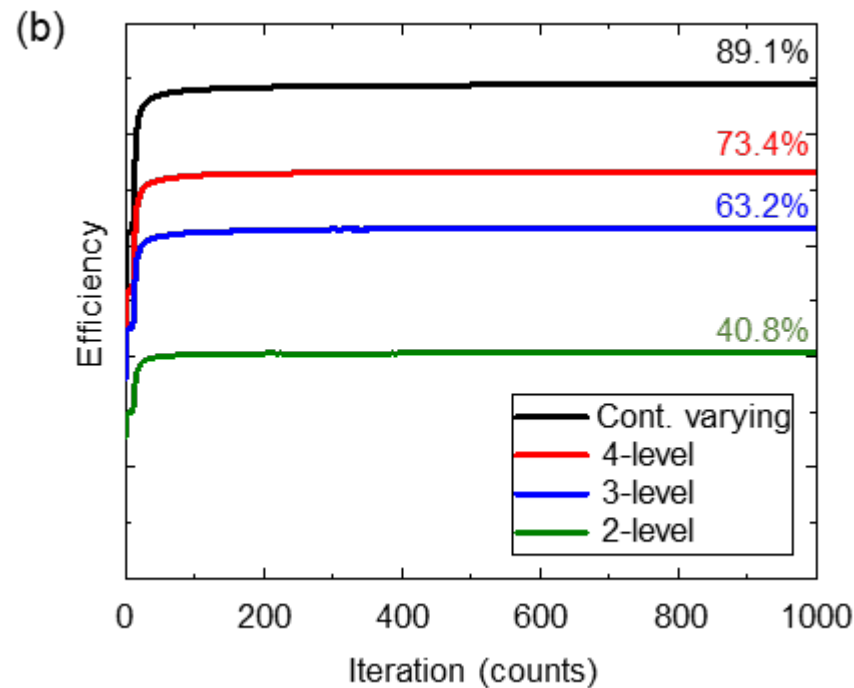

## Meta-hologram design

- Depending on the nanostructures used, the rendering is polarization-dependent
- Since the nanostructure resonance depends on the wavelength, the hologram will also change with the illumination wavelength

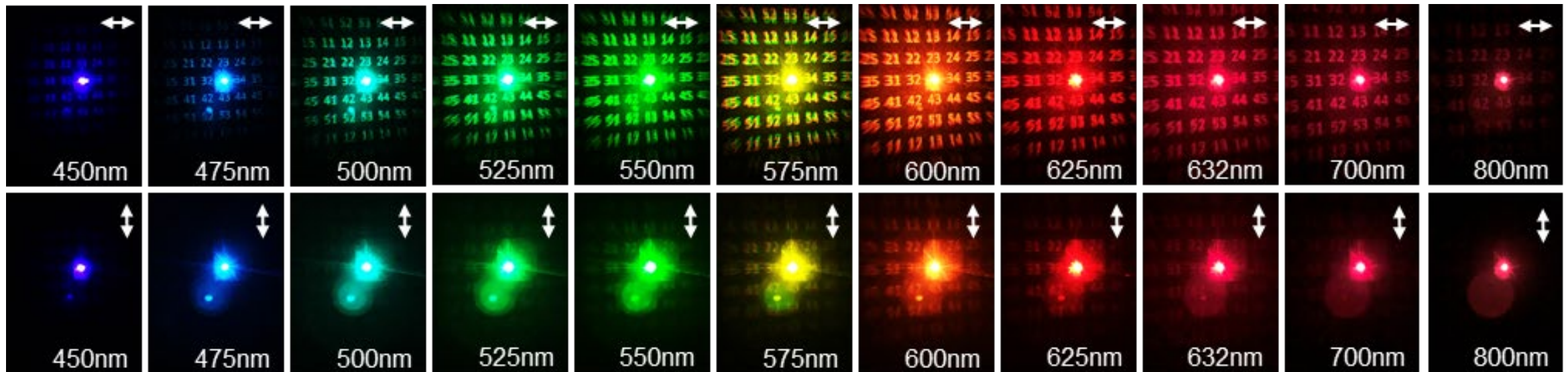

# Selected Topics in Advanced Optics

---

## Week 12 – part 4

Olivier J.F. Martin  
Nanophotonics and Metrology Laboratory

**EPFL**

## Plasmonic bright mode

- A bright mode is a mode that can radiate into the far-field
- The simplest and most useful bright mode is an electric dipole mode
- More complex modes can be obtained by the superposition of electric dipoles
- Numerical technique:  
coupled-dipole approximation  
(or discrete-dipole approximation)

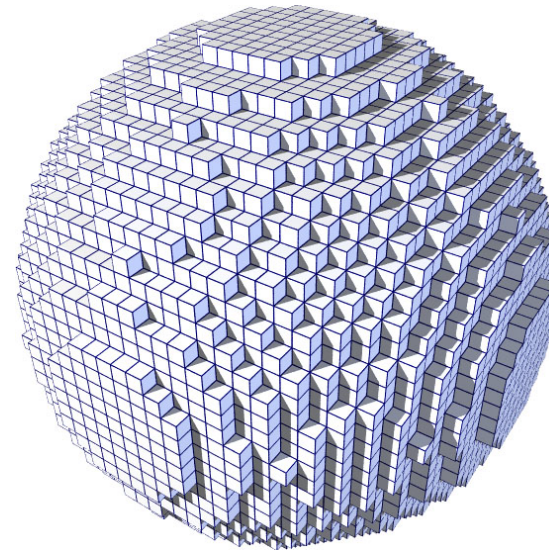
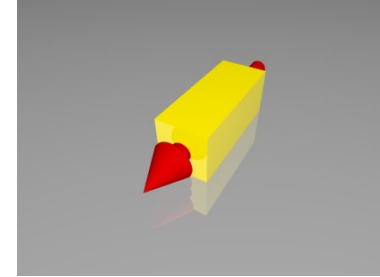
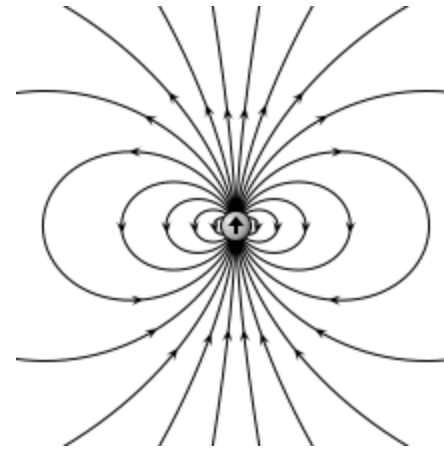

## Plasmonic dark mode

- A dark mode does not radiate into the far-field...  
... but it can have a strong near-field
- The simplest dark mode is an electric quadrupole:

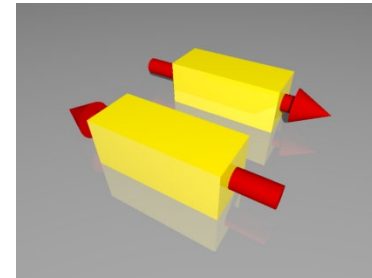
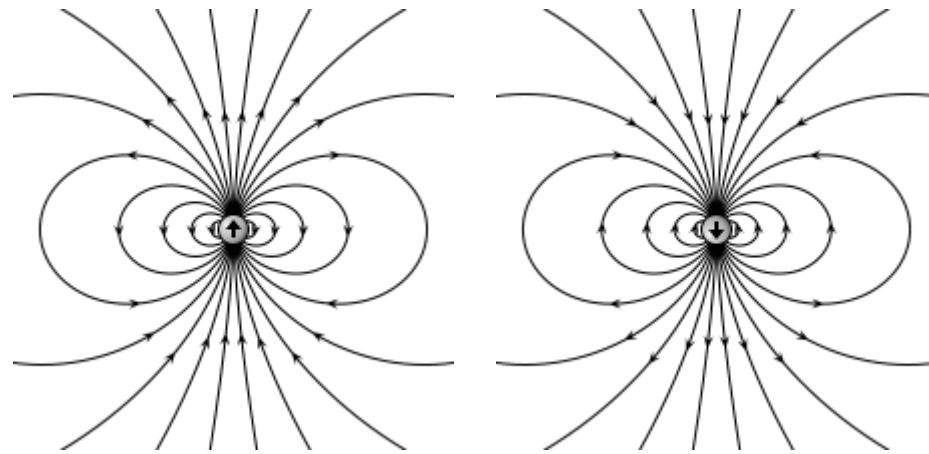

- An electric quadrupole corresponds to a small current loop (magnetic resonance)

# Lorentz model

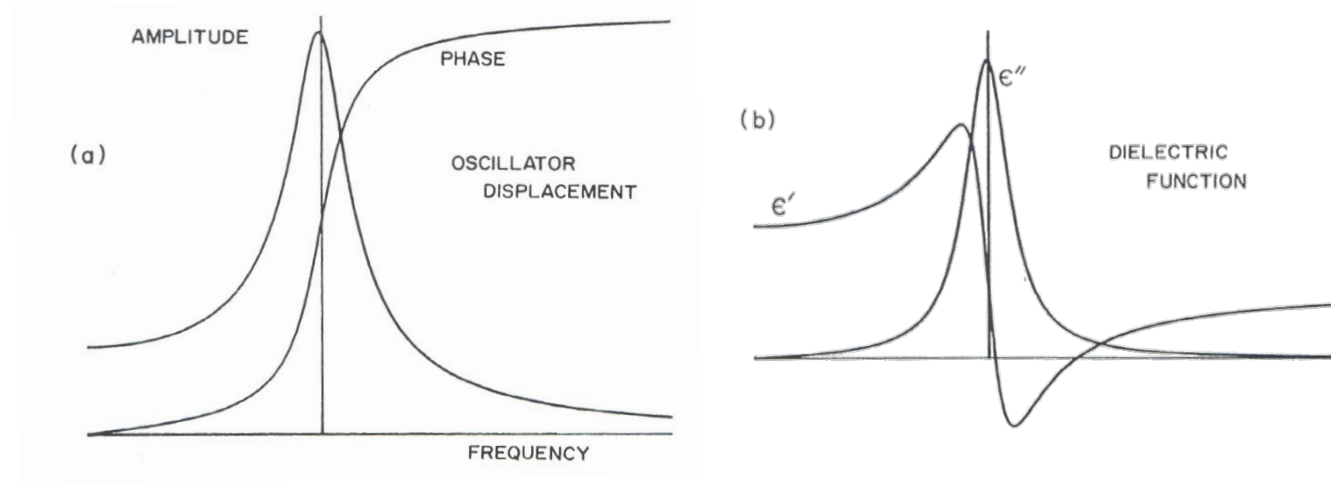

- The amplitude is maximum for  $\omega = \omega_0$  and the width inversely proportional to  $\gamma$
- At low frequency the oscillator is in-phase ( $\Theta = 0$ ) and at high frequency it is out of phase by  $180^\circ$ . The change occurs at  $\omega \simeq \omega_0$
- The induced dipole moment of a single oscillator is  $\mathbf{p} = e\mathbf{x}$
- For a collection of  $n$  oscillators per volume unit, the polarization is  $\mathbf{P} = ne\mathbf{x}$

$$\mathbf{P} = \frac{\omega_p^2}{\omega_0^2 - \omega^2 - j\gamma\omega} \varepsilon_0 \mathbf{E} \quad \text{plasma frequency : } \omega_p^2 = ne^2 / m\varepsilon_0$$

- Since  $\mathbf{P} = \varepsilon_0 \chi \mathbf{E} \rightarrow \varepsilon_r = 1 + \chi = 1 + \frac{\omega_p^2}{\omega_0^2 - \omega^2 - j\gamma\omega}$

# Resonant electromagnetic systems

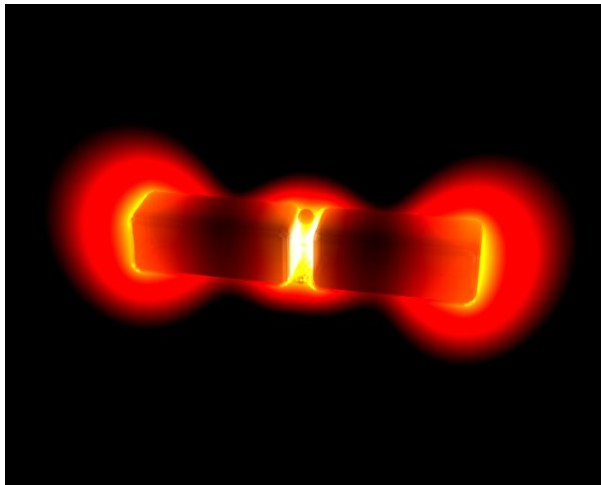
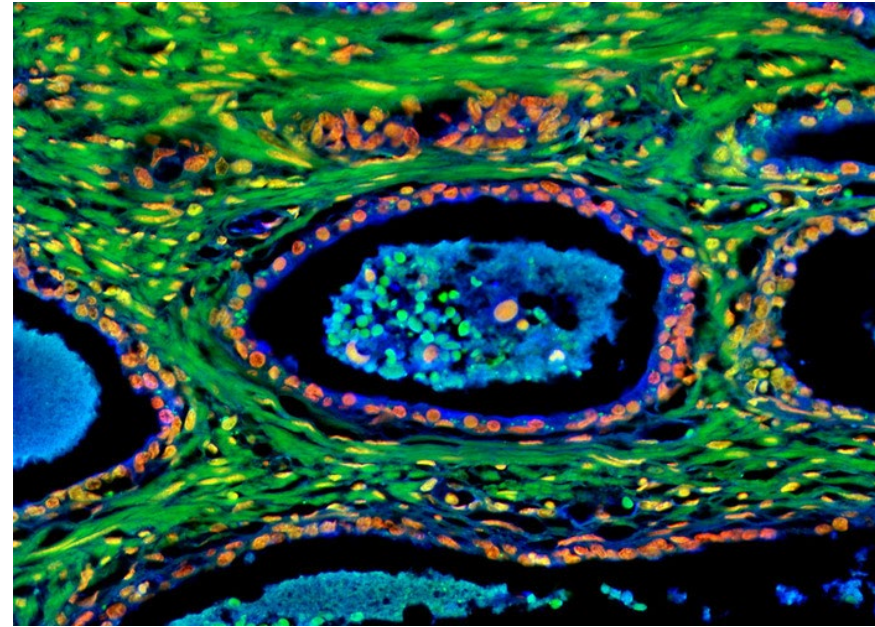
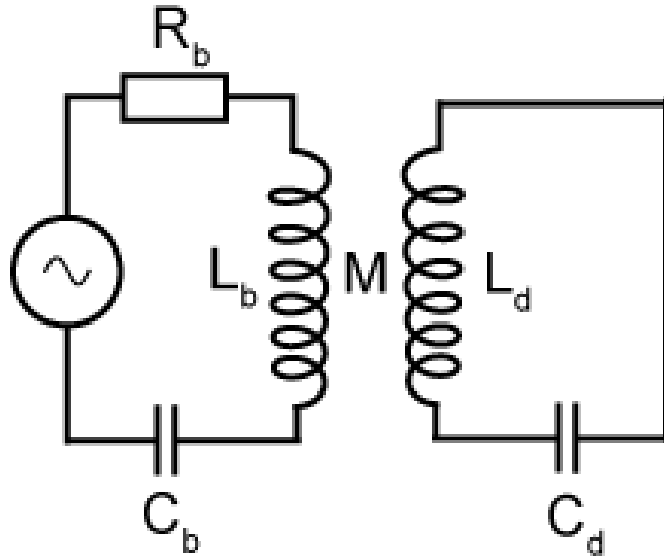

## Lorentzian lineshape

- These different systems have a Lorentzian response  
(the signal amplitude as a function of energy/frequency follows a Lorentzian curve)

$$\varphi(\omega) = \frac{\gamma}{(\omega - \omega_0)^2 + \gamma^2}$$

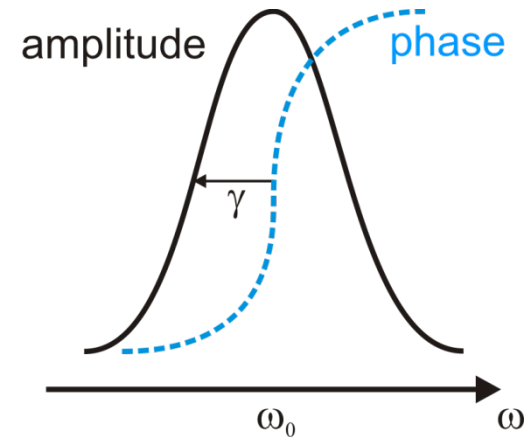

- When two oscillators are interacting, their responses can be combined, producing a Fano lineshape:

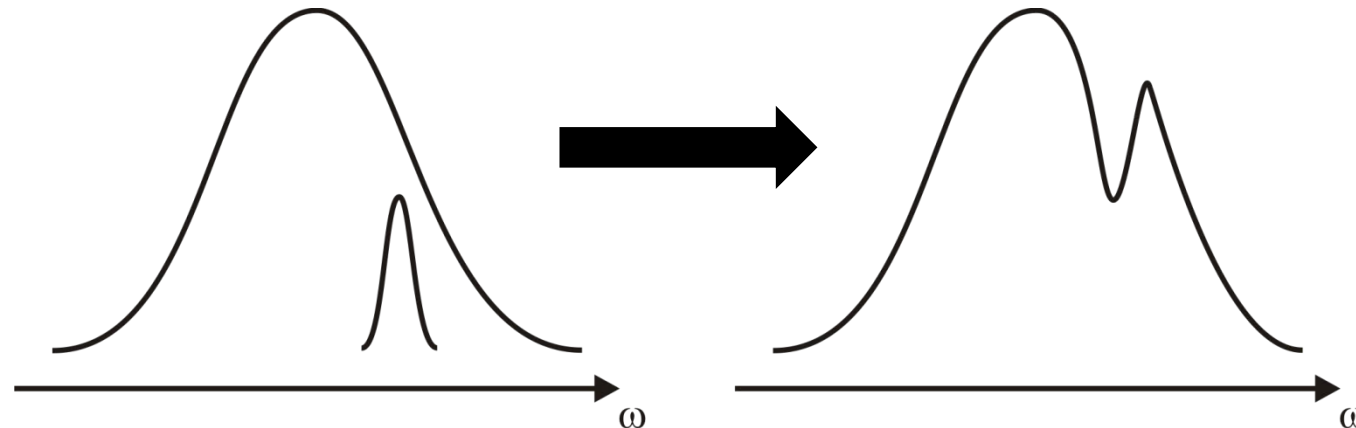

# The original work of Ugo Fano in atom spectroscopy

- The asymmetric lineshape originates from the interference of two ionization processes



**Ugo Fano**  
(1912-2001)

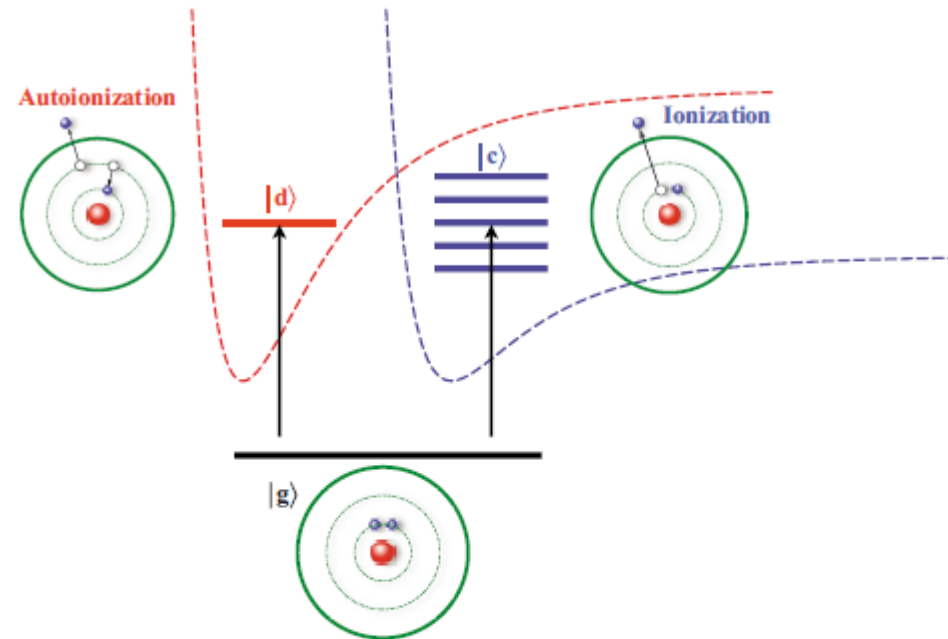
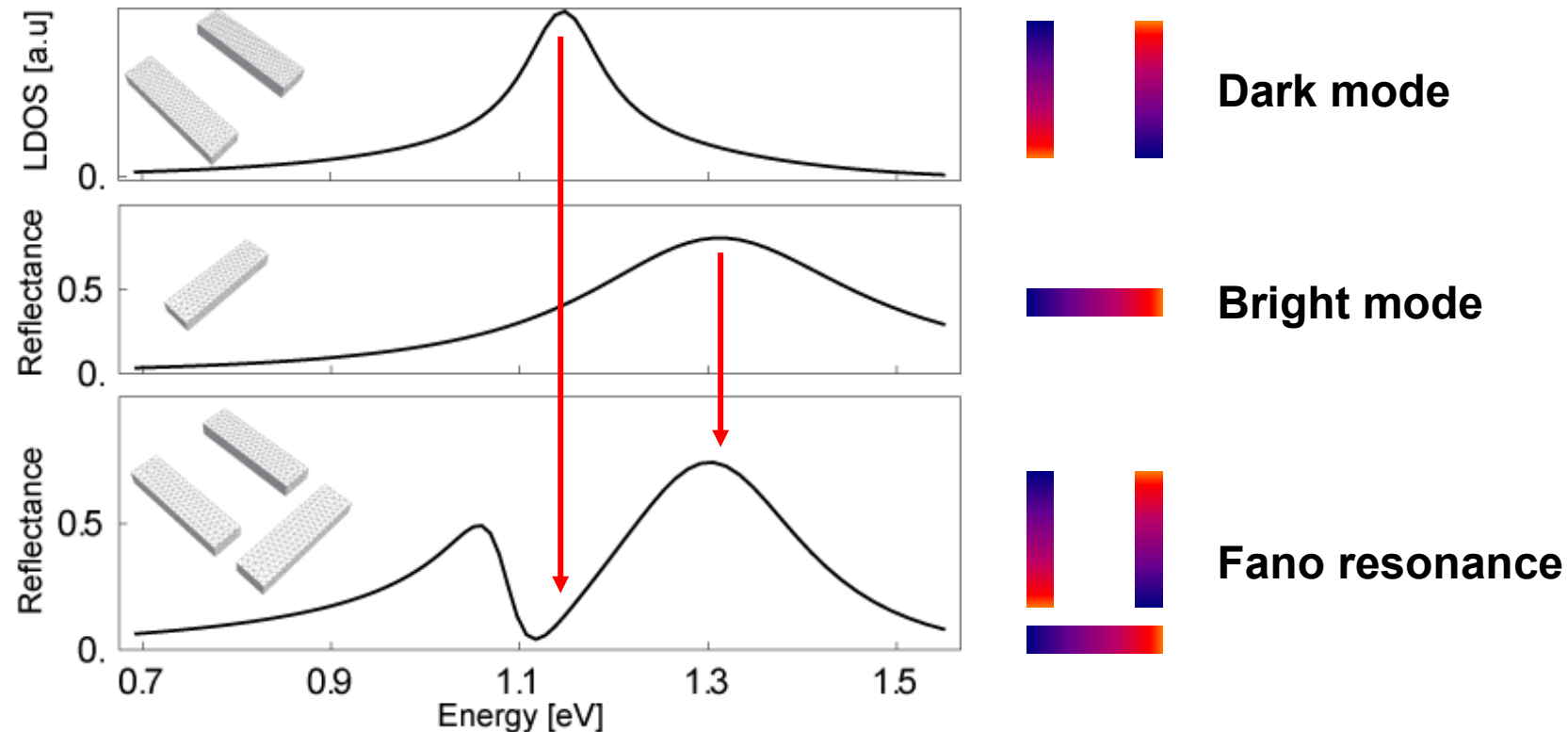

FIG. 3. (Color online) Fano resonance as a quantum interference of two processes: direct ionization of a deep inner-shell electron and autoionization of two excited electrons followed by the Auger effect. This process can be represented as a transition from the ground state of an atom  $|g\rangle$  either to a discrete excited autoionizing state  $|d\rangle$  or to a continuum  $|c\rangle$ . Dashed lines indicate double excitations and ionization potentials.

# Fano resonances in plasmonic systems

- Constructive and destructive interference of a bright mode with a dark mode



- Fano resonances are best studied in energy scale
- The interference can be constructive or destructive, depending on the portion of the spectrum

# Coupled oscillator models

Bright mode Dark mode

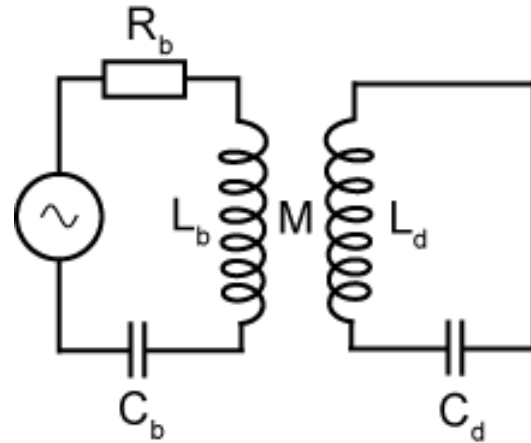

Bright mode Dark mode

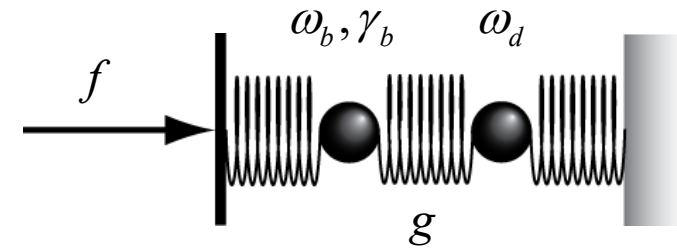

- Bright mode response: 
$$c_b = \frac{\omega_d^2 - \omega^2}{(\omega_b^2 + i\gamma_b\omega - \omega^2)(\omega_d^2 - \omega^2) - g^2} f$$

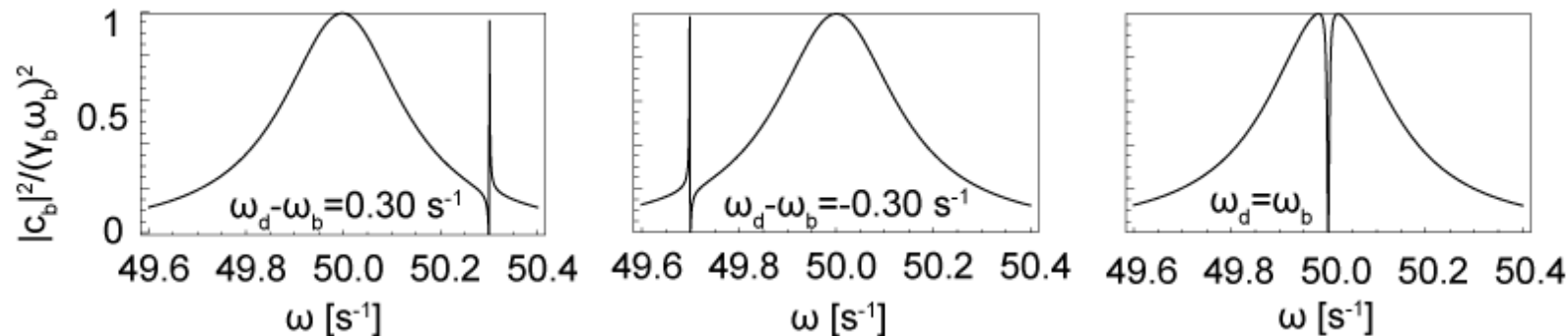

*W.E. Lamb, Phys. Rev. **81**, 222 (1951)*

*C.L.G. Alzar, Am. J. Phys. **70**, 37 (2002)*

*Y.S. Joe, Phys. Scr. **74**, 259 (2006)*

# Coupled oscillators models

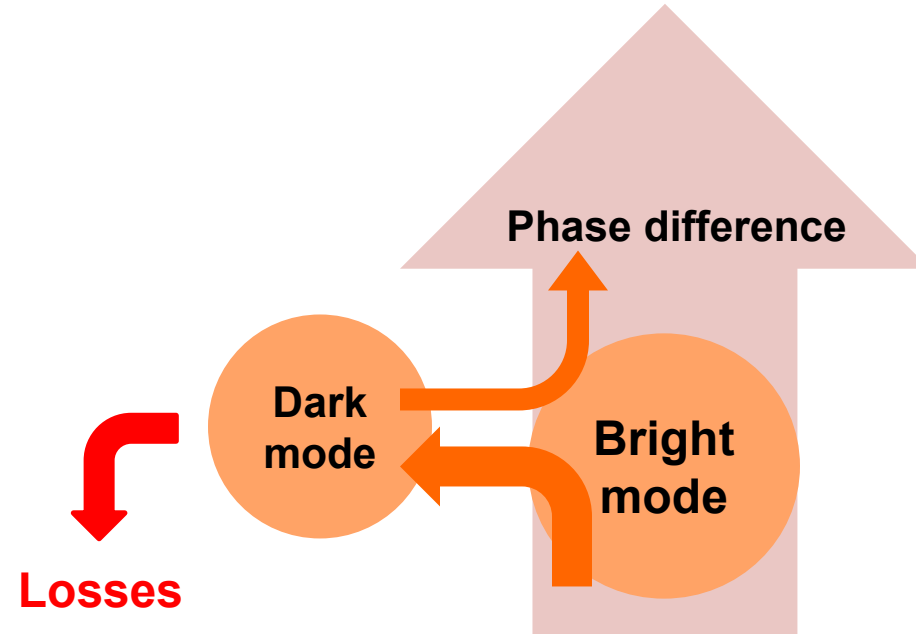
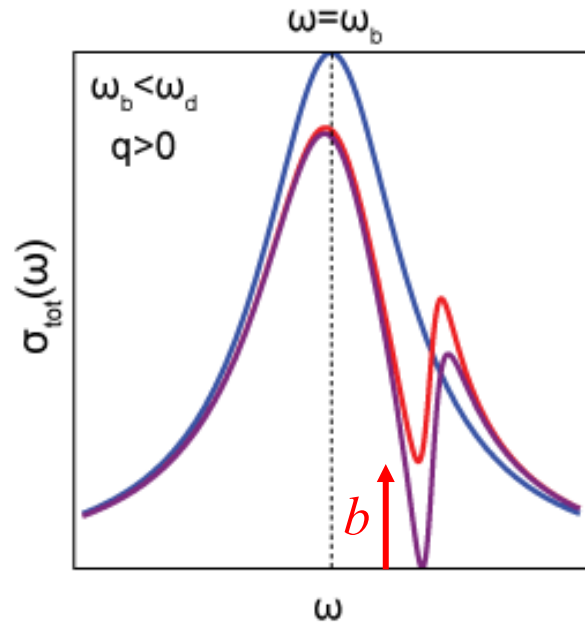

- Modified Fano formula:

$$|c_b|^2 = \frac{|f|^2}{|C|^2} \frac{(\kappa + q)^2 + b}{\kappa^2 + 1}$$

$$\Gamma = \underbrace{(\Gamma_i)}_{\text{Intrinsic losses}} + \underbrace{(\Gamma_c)}_{\text{Coupling losses}}$$

**Intrinsic losses**      **Coupling losses**

- Modulation damping by losses:

$$b = \frac{\Gamma_i^2}{(\Gamma_i + \Gamma_c)^2}$$

$$q = \frac{\omega_d^2 - \omega_b^2}{\gamma_b \omega_d (1 + \Gamma_i / \Gamma_c)}$$

# Combining bright and dark modes

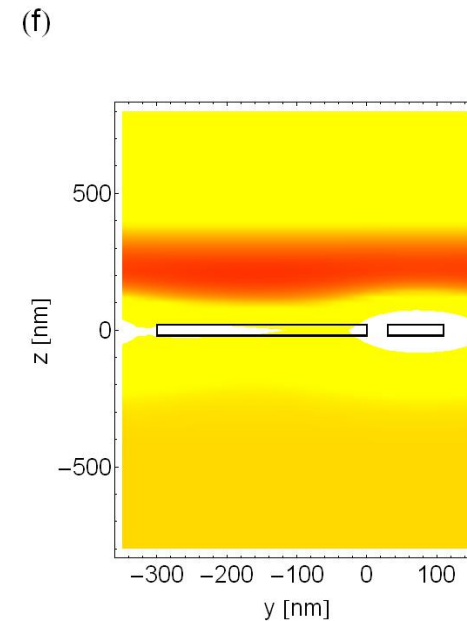
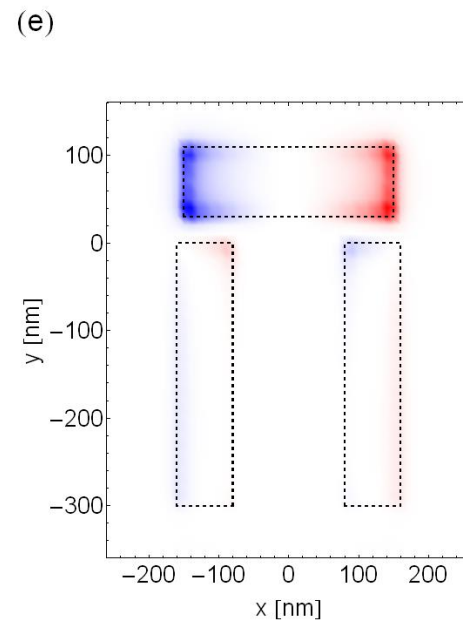
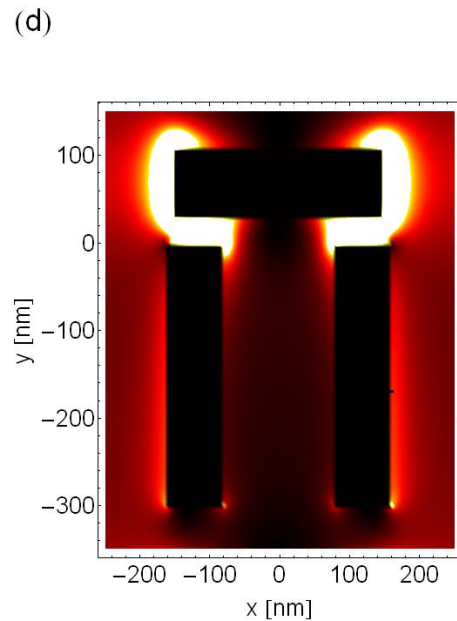
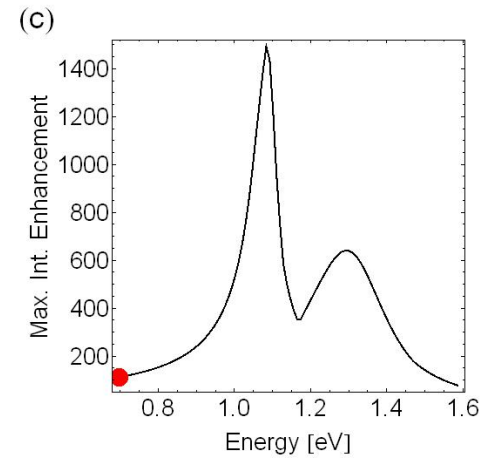
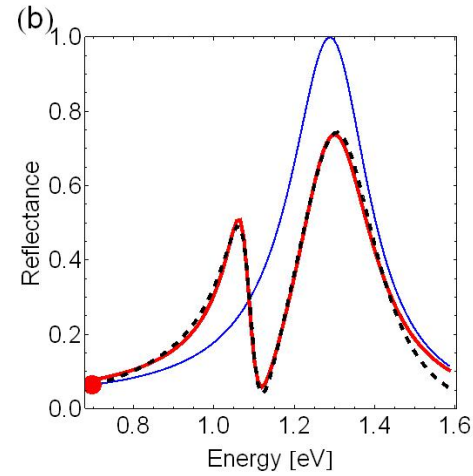
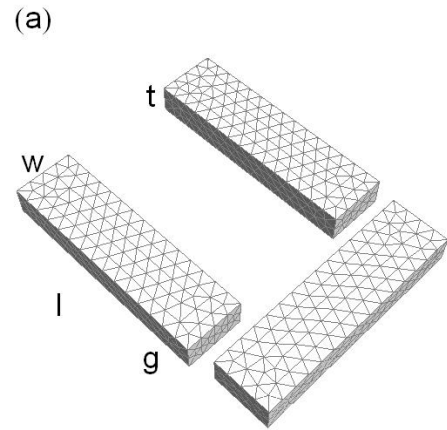

# Combining bright and dark modes

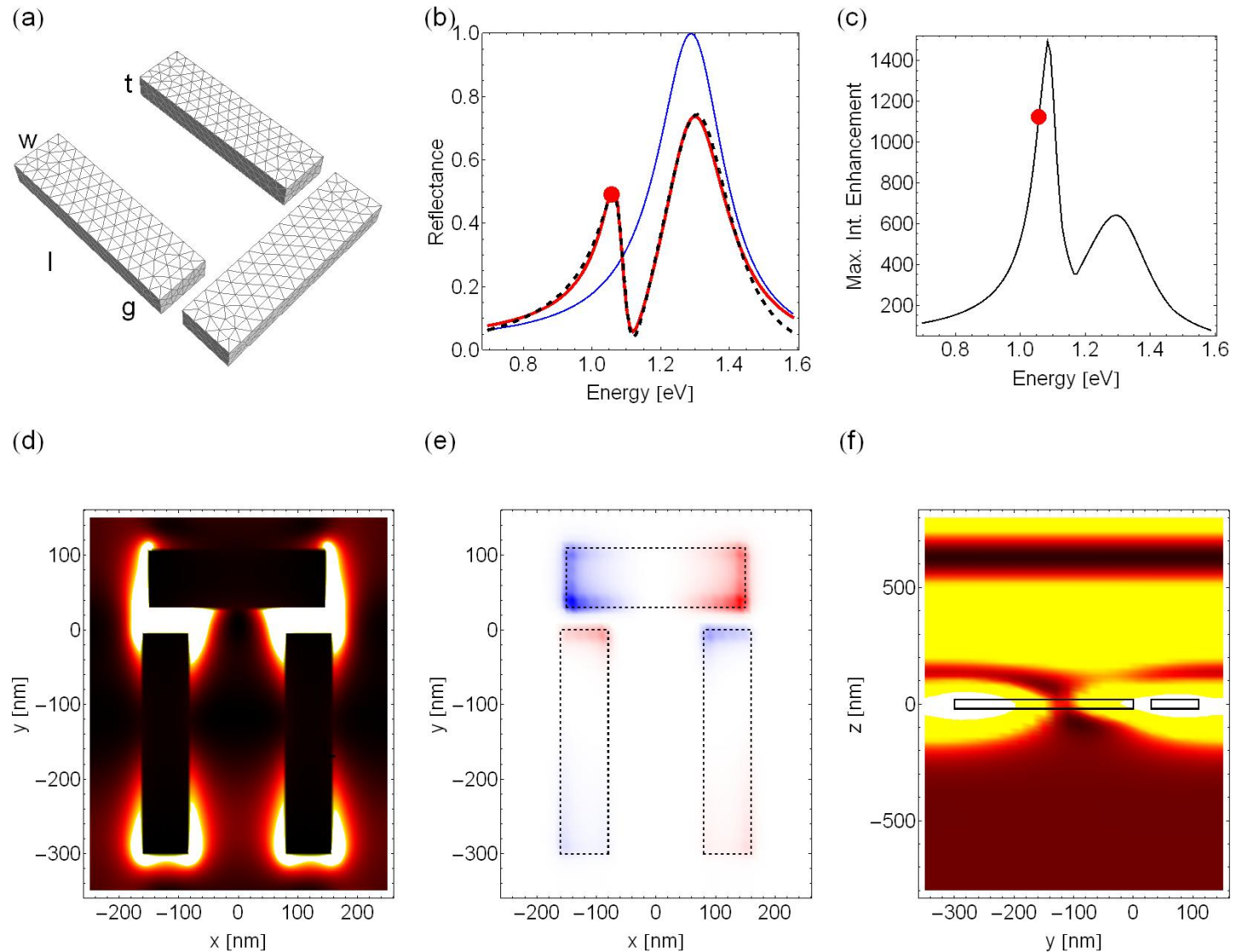

# Combining bright and dark modes

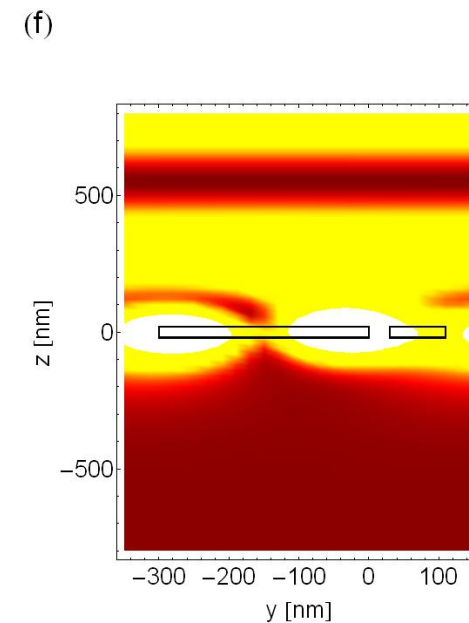
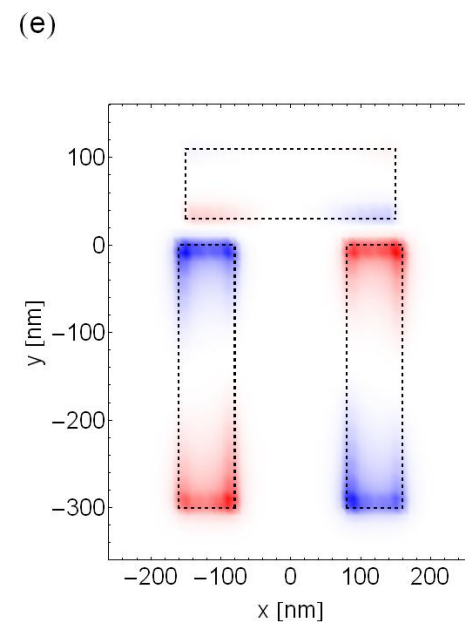
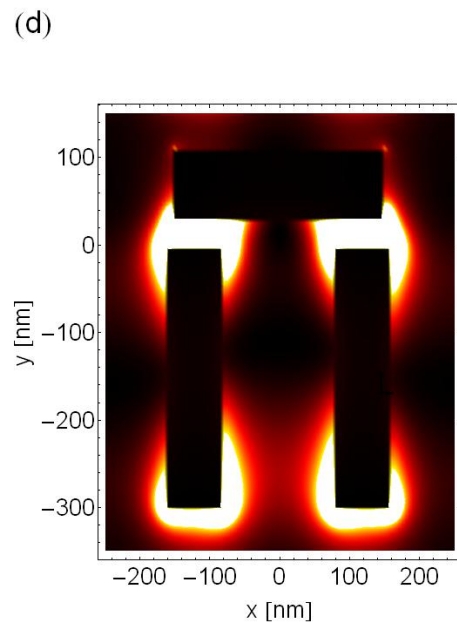
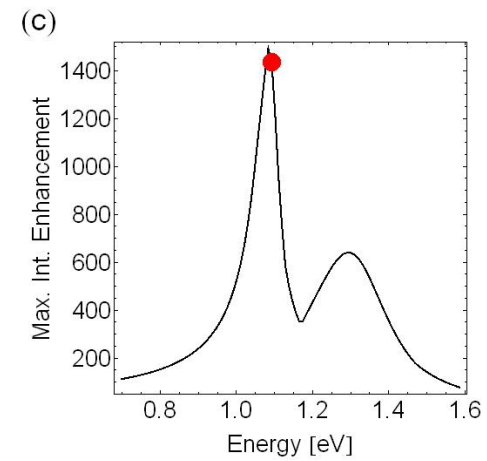
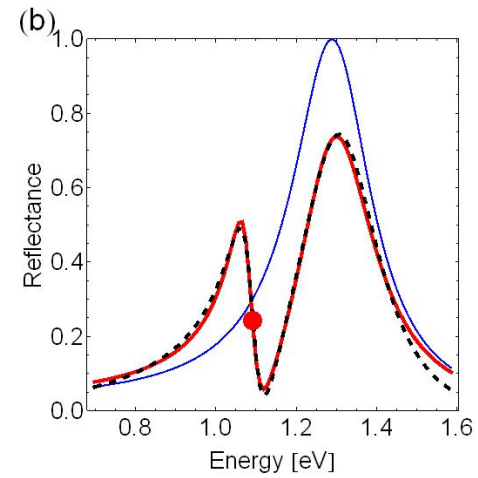
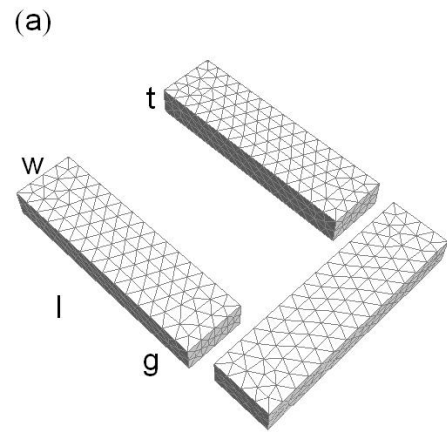

# Combining bright and dark modes

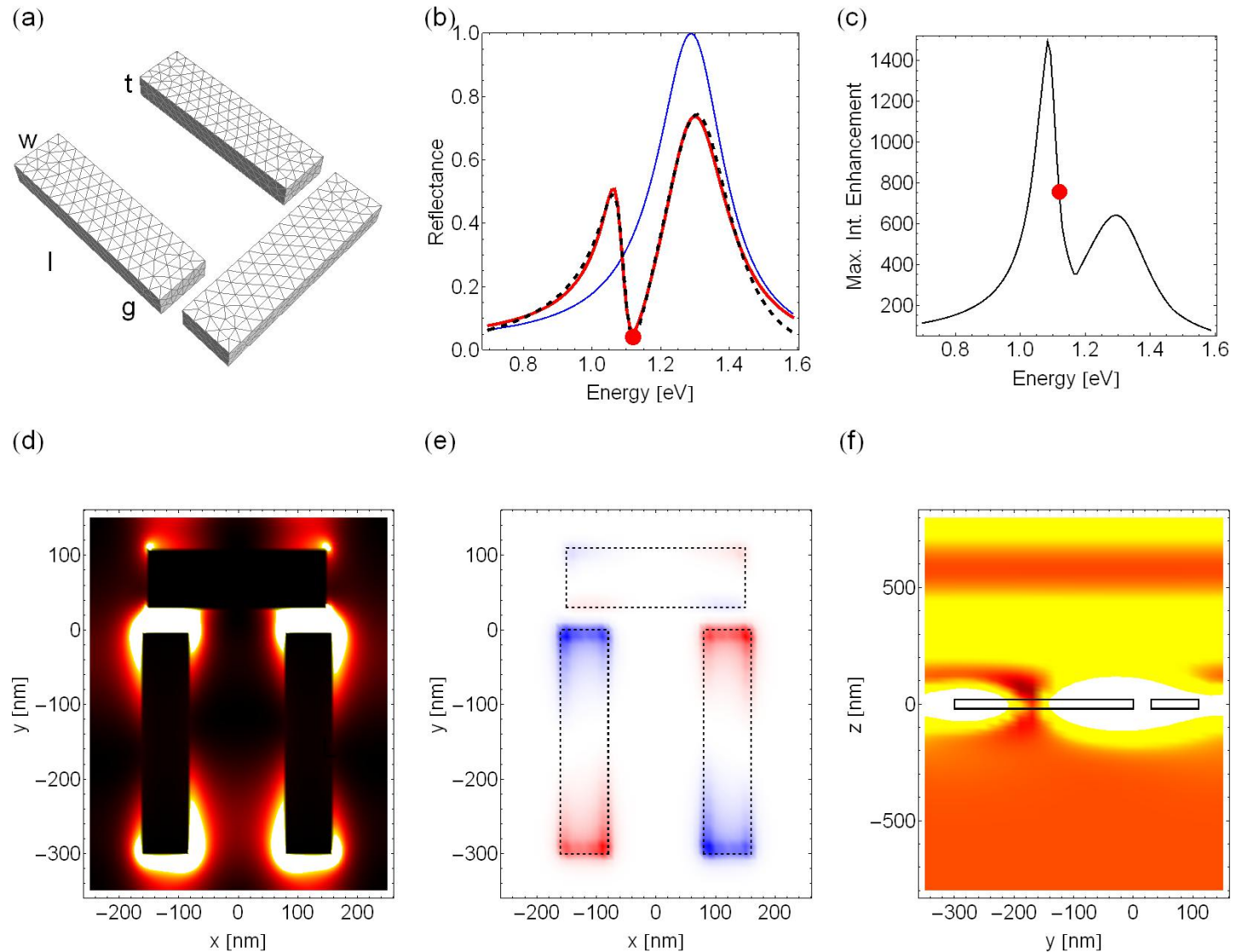

# Combining bright and dark modes

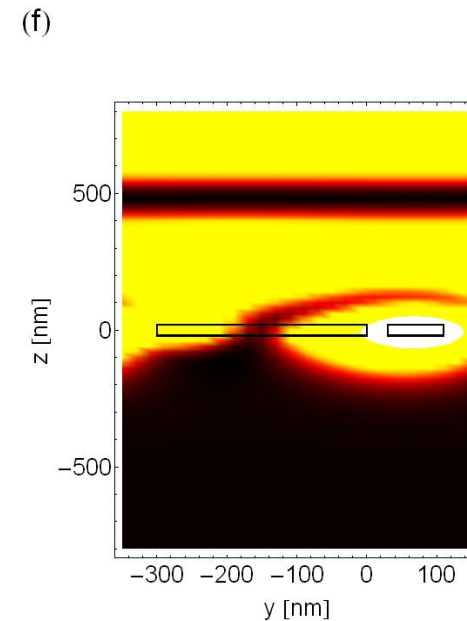
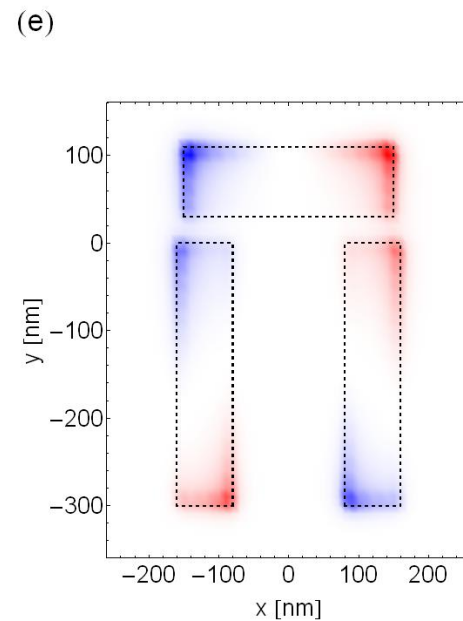
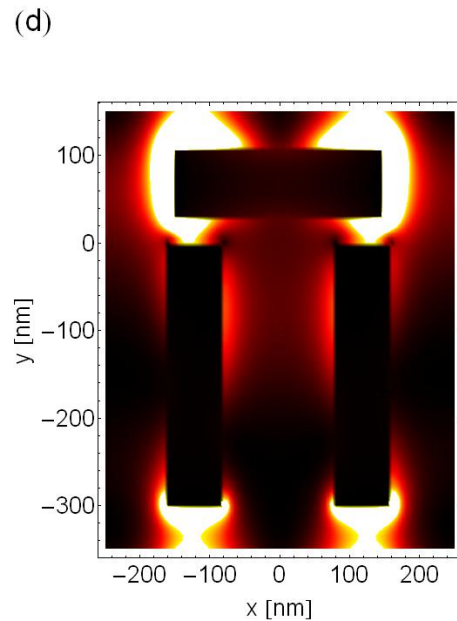
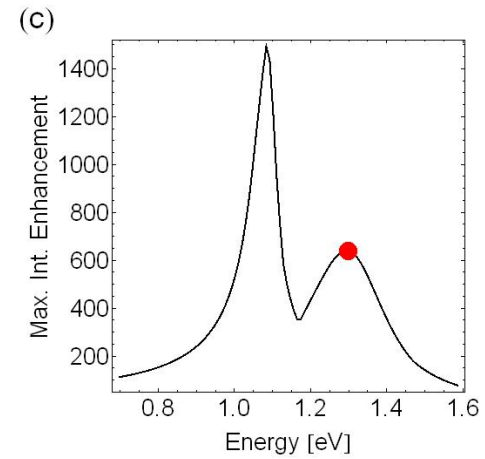
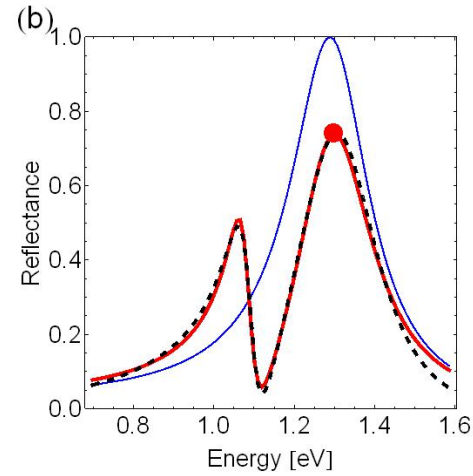
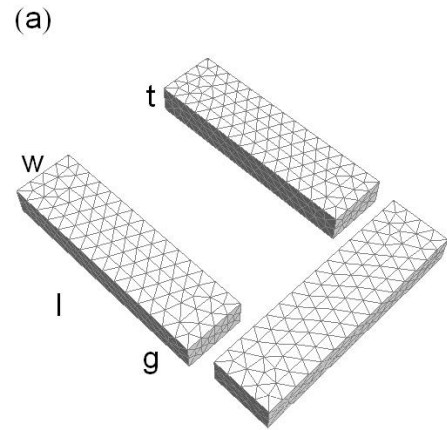

# Combining bright and dark modes

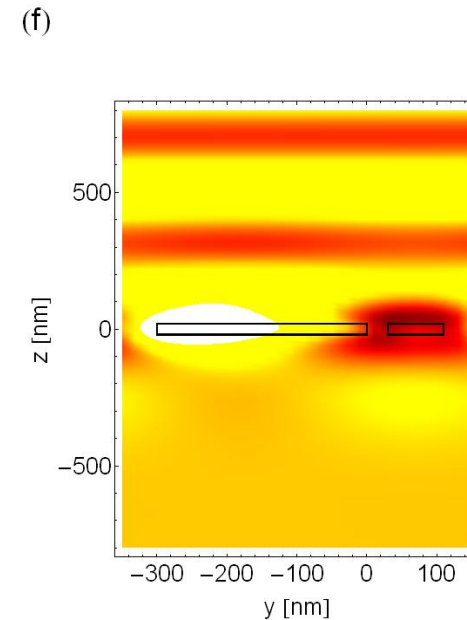
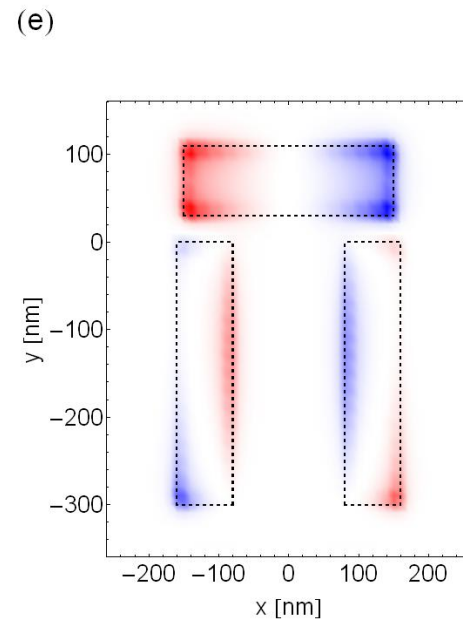
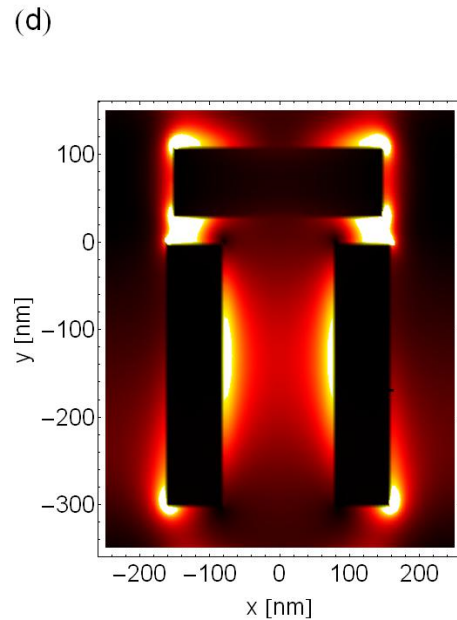
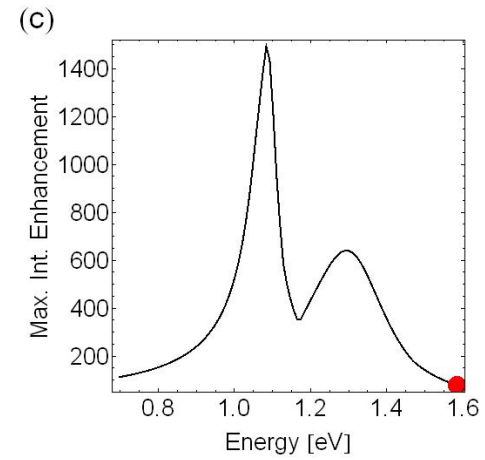
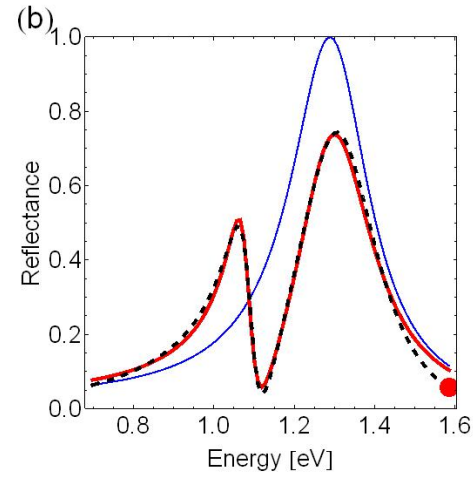
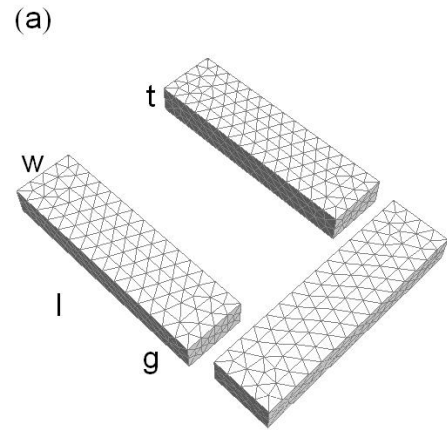

# Fano resonance engineering

- Decompose the experimental signal by fitting the formula

- - - - Numerical/experimental    — Bright mode  
 — Generalized formula        — Dark mode

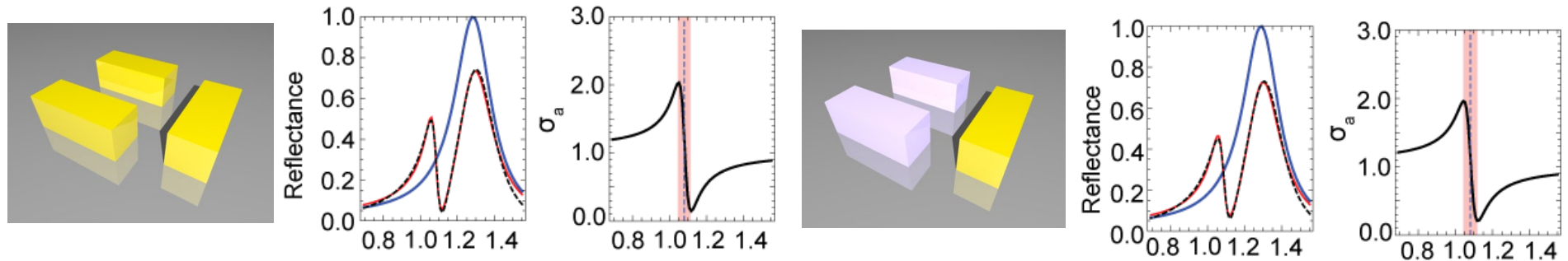

**Increasing losses**

➤ **Less modulation, wider resonance**

**Decreasing coupling**

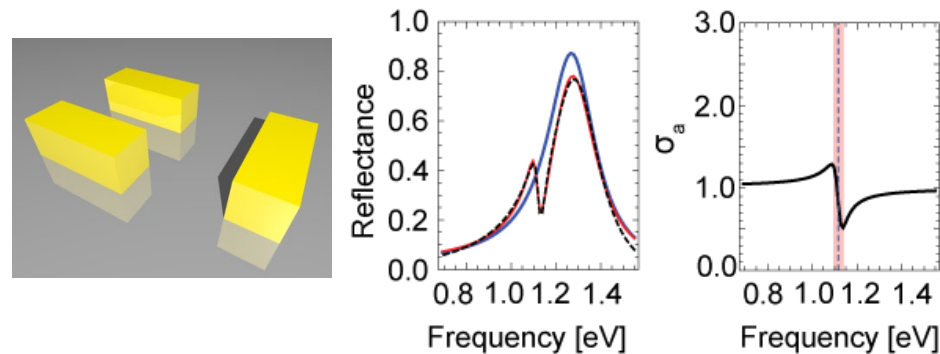

➤ **Less modulation, narrower resonance**

**Reversing modes detuning**

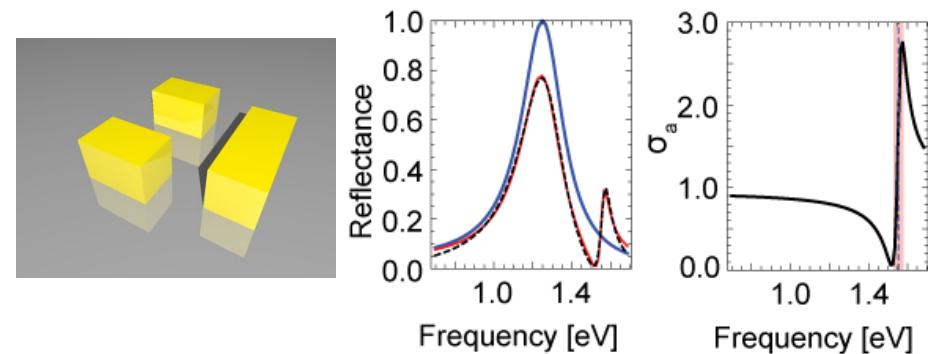

➤ **Asymmetry reversal**

# Selected Topics in Advanced Optics

---

## Week 12 – part 5

Olivier J.F. Martin  
Nanophotonics and Metrology Laboratory

**EPFL**

# Narrow band Fano-resonant metasurface

- A cell contains 4 Fano-resonant nanostructures that each provide a different phase to the reflected wave

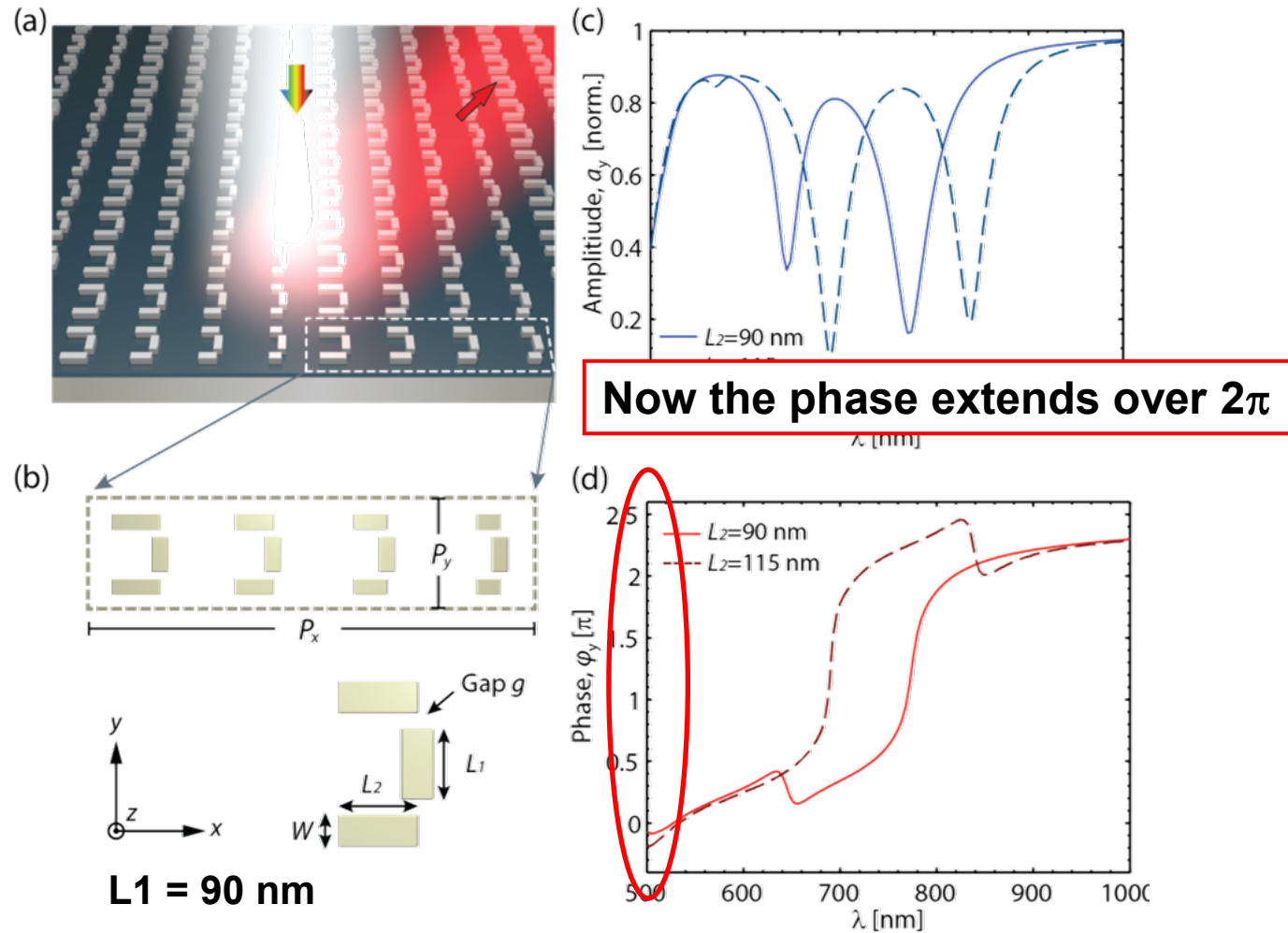

# Narrow band Fano-resonant metasurface

- A cell contains 4 Fano-resonant nanostructures that each provide a different phase to the reflected wave
- The bright mode determines the central resonance
- The bandwidth is controlled by tuning the dark mode

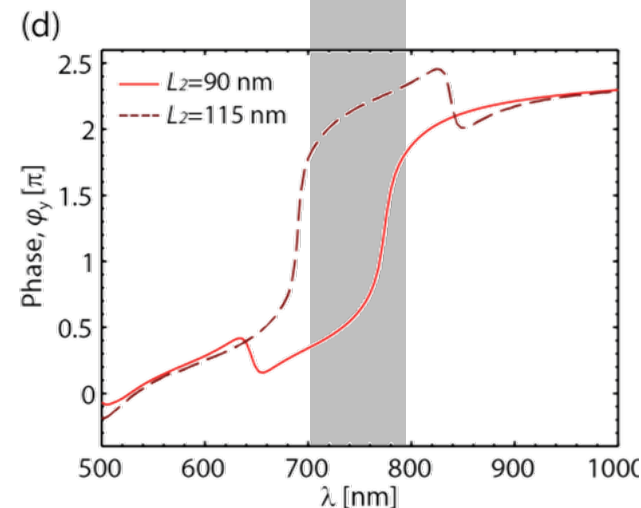
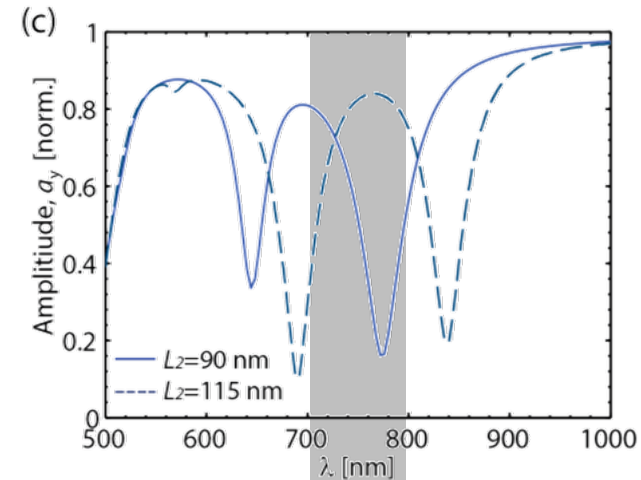
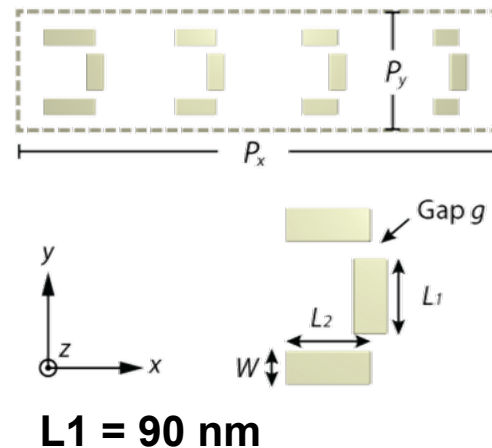

# Narrow band Fano-resonant metasurface

- Spectral range of  $\sim 100$  nm with a highly tunable phase shift between 0 and  $1.9\pi$
- Outside that spectral range the system behaves as a normal reflective surface

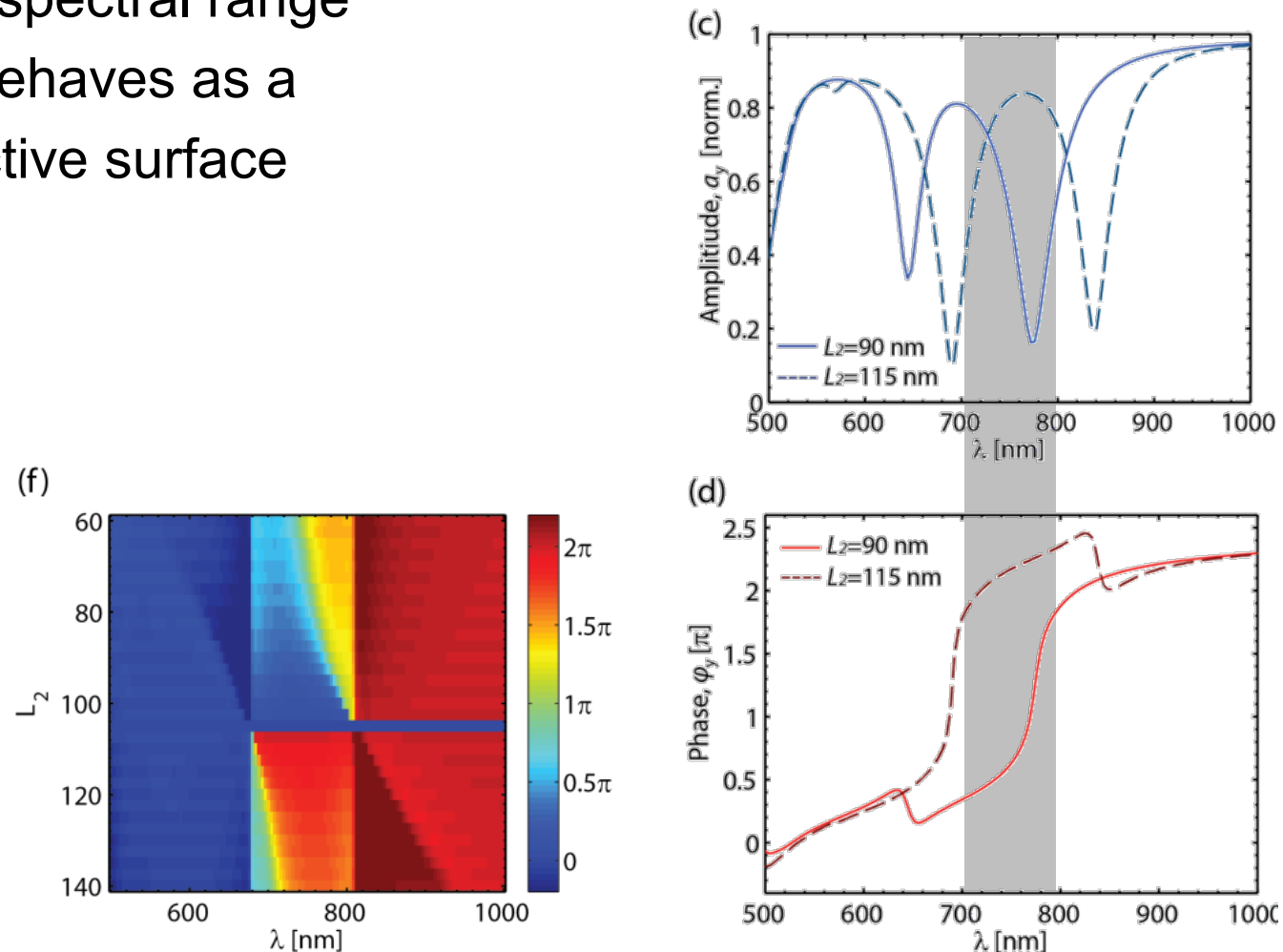

## Narrow band Fano-resonant metasurface

- We want to work in the visible range, which imposes additional constraints on the possible coinage metal to be used (silver and aluminum are especially well suited)

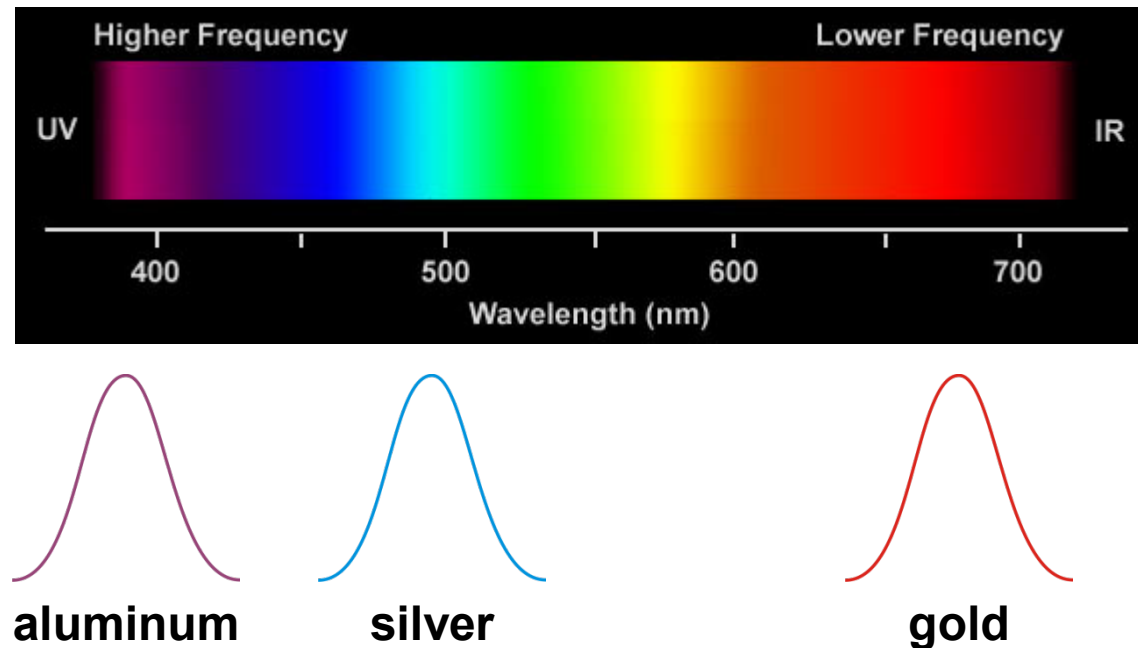

# Narrow band Fano-resonant metasurface

- At  $\lambda = 750$  nm, anomalous reflection with high efficiency
- Good agreement with the generalized Snell law

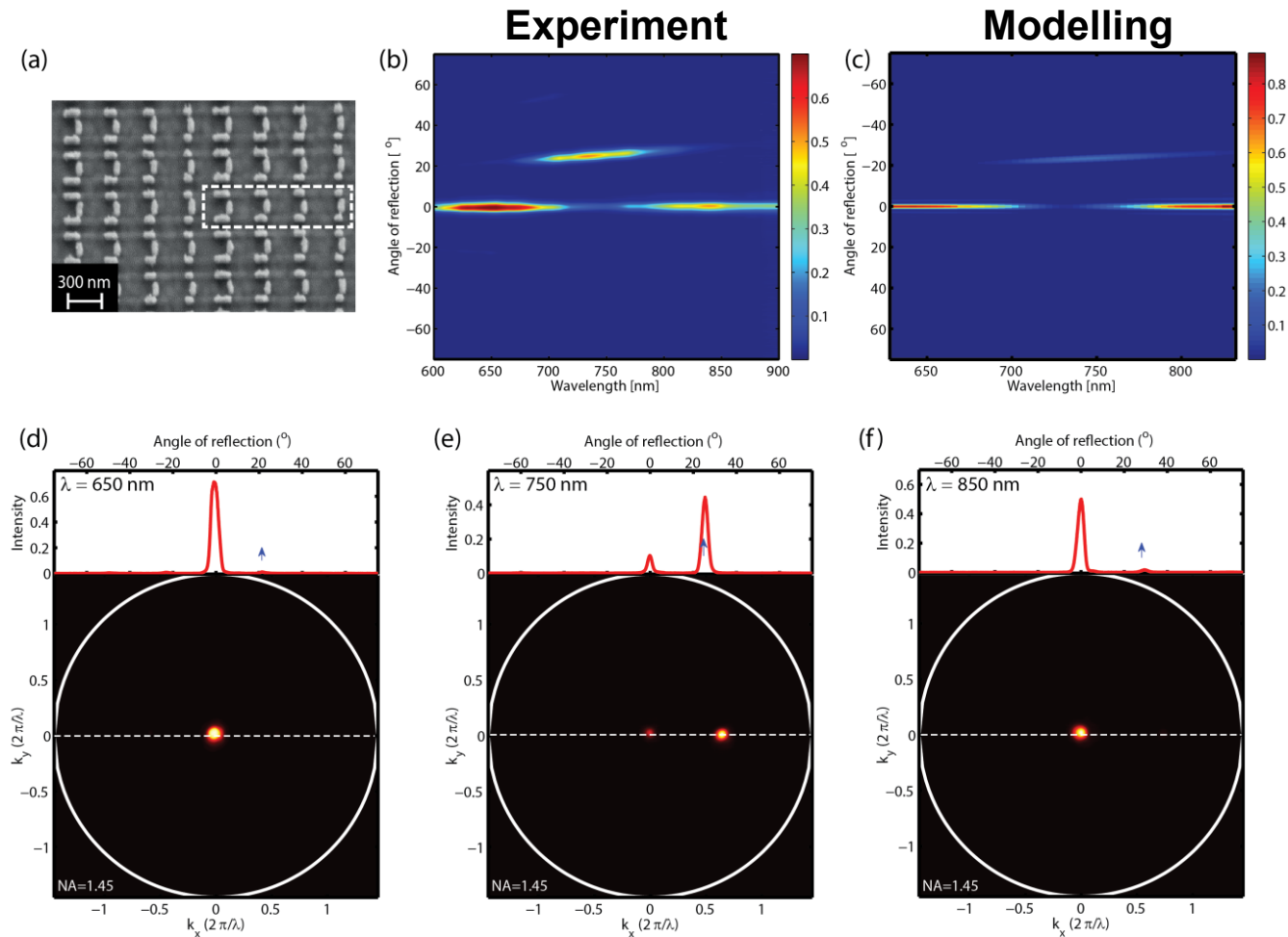

# Colour routing with a Fano-resonant metasurface

- Two different unit cells centered at  $\lambda_1 = 532$  and  $\lambda_2 = 660$  nm

