

Problem set 5

Problem 1

Consider the two-dimensional truss structure depicted in the figure below. The structure consists of two linear elastic truss elements, each characterized by a modulus of elasticity E and a constant cross-sectional area A . The structure is modeled using three nodes and two finite elements within a global coordinate system whose origin is located at node 1.

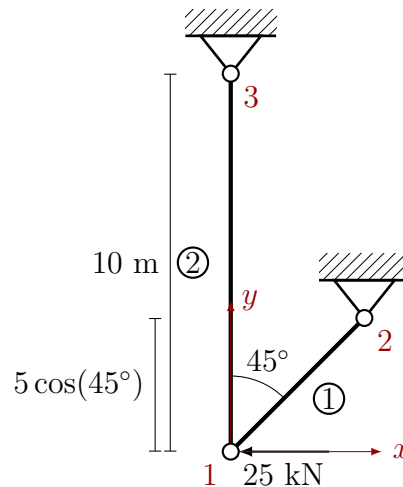

The truss is subjected to an external horizontal load of 25 kN applied at node 1.

- Degree of freedom classification: using the finite element discretization, the system has a total of six degrees of freedom, two per node. Identify which of these degrees of freedom are constrained due to boundary conditions, and which are unconstrained.
- Reduced system formulation: by eliminating the constrained degrees of freedom, compute the reduced stiffness matrix and the reduced applied loads vector corresponding to the unconstrained degrees of freedom of the structure.
- Displacement calculation: solve the reduced system to obtain the displacements at the unconstrained degrees of freedom.
- Stress evaluation: using the computed displacements, determine the approximate axial stress in each truss element. Then, provide a physical interpretation of the results: which member is in tension or compression, and why?

Problem 2

Consider the two-dimensional truss structure illustrated below, composed of three inclined bars made of structural steel. The material and geometric properties of each member are as follows:

- Young's modulus: $E = 210 \text{ GPa}$
- Cross-sectional area: $A = 6.45 \times 10^{-4} \text{ m}^2$
- Density $\rho = 7800 \text{ kg/m}^3$

Node 1 is fully constrained, while node 3 is constrained in the vertical (y) direction only. These boundary conditions result in a system with three unconstrained degrees of freedom.

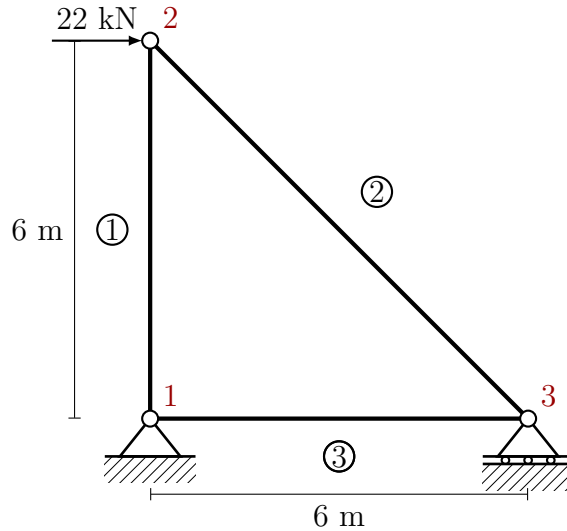

Develop a **MATLAB** script that performs the following tasks:

1. Assemble the global stiffness matrix \mathbf{K} and consistent mass matrix \mathbf{M} of the truss structure.
2. Compute the natural frequencies ω_i and the corresponding mode shapes ϕ_i .
3. Determine the time response of the structure when subjected to a constant external force $f = 22 \text{ kN}$ applied at node 1 along the horizontal (x) direction.
 - a) Use modal decomposition to transform the coupled second-order differential system

$$\mathbf{M}\ddot{\mathbf{q}}(t) + \mathbf{K}\mathbf{q}(t) = \mathbf{f}(t)$$

into a system of uncoupled scalar equations by expressing the displacement vector as $\mathbf{q}(t) = \mathbf{\Phi}\mathbf{z}(t)$, where $\mathbf{\Phi}$ is the modal matrix formed by mass-normalized mode shapes.

- b) More precisely, apply the orthogonality conditions

$$\mathbf{\Phi}^T \mathbf{M} \mathbf{\Phi} = \mathbf{I}, \quad \mathbf{\Phi}^T \mathbf{K} \mathbf{\Phi} = \mathbf{\Lambda}$$

with $\mathbf{\Lambda} = \text{diag}(\lambda_1, \dots, \lambda_n)$, to derive and solve the uncoupled system governing the modal coordinates $\mathbf{z}(t)$.

- c) Solve the uncoupled system and compute the time response vector \mathbf{q} at the unconstrained degrees of freedom.