

Solar Energy Conversion Devices and Plants: Exercise 7

In this exercise, you will simulate a cyclic voltammetry experiment and study the effect of operating conditions and materials on the system response. This is an individual computational work that will be graded (average of 2 out of 3 computational exercises will be 22% of final mark). Submission deadline of code and short report is December 8, 2025, 14:15, by email to Prof. Haussener.

Electrochemical kinetics: Cyclic voltammetry

Simulate a cyclic voltammetry experiment in an aqueous system which couples an one-electron electrochemical reaction at an electrode surface with a homogeneous chemical reaction of the reduced species in the solution (schematic in figure 1):

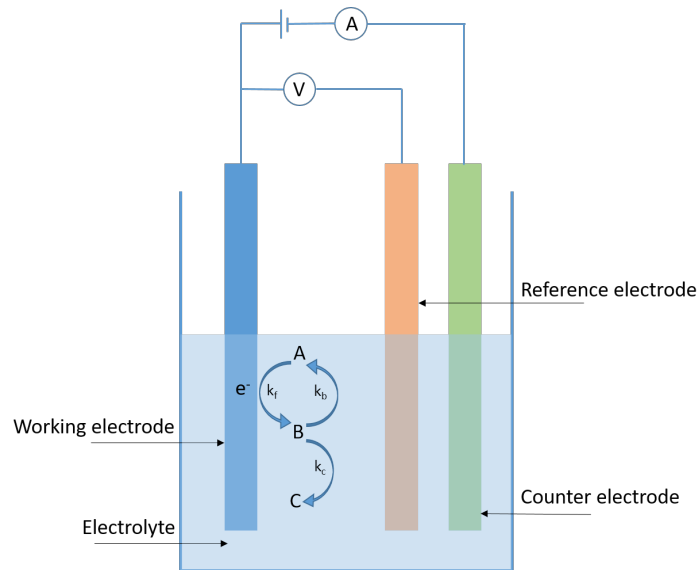
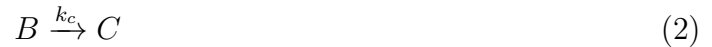

Figure 1: Scheme of the half-reaction system where species A is reduced to species B in a heterogeneous chemical reaction at the electrode, and species B reacts subsequently in a homogeneous chemical reaction in the solution to produce species C. k_f is the forward rate constant of the heterogeneous electrochemical reaction, k_b is the backward rate constant of the heterogeneous electrochemical reaction, and k_c is the chemical rate constant of the homogeneous chemical reaction.

Assume that

- a) The initial concentration of species A is $c_A = 1 \text{ mol/l}$
- b) The diffusion coefficients of species A and B are $D_A = D_B = 1.10^{-5} \text{ cm}^2/\text{s}$
- c) The pre-exponential electrochemical rate constant is $k_0 = 1.10^{-2} \text{ cm/s}$
- d) The charge transfer coefficient of the electrochemical reaction is, $\alpha = 0.5$
- e) The rate constant of the homogeneous chemical reaction is $k_c = 1.10^{-3} \text{ 1/s}$
- f) The temperature of the system is $T = 298 \text{ K}$
- g) The sweep rate is $v = 0.001 \text{ V/s}$ and the initial and final overpotentials (with respect to the redox potential A/B) of your sweep are $+0.3$ and -0.3 V

Questions

- a) Compute and plot the current vs time, potential vs time, and a cyclic voltammogram (CV, i.e. current vs potential) using the given assumptions and sweep your potential within the initial and final overpotentials vs the redox potential of A/B.
- b) Plot and explain the effect of k_c on the CVs in terms of chemical reversibility.
- c) Plot and explain the effect of k_0 on the dimensionless "electrochemical reversibility" parameter, $\Lambda = k_0 / \sqrt{D \cdot F / (\tilde{R}T) \cdot v}$ ($\tilde{R} = 8.314 \text{ J}/(\text{molK})$, $F = 96'485 \text{ C/mol}$), and plot the varying CVs.
- d) Determine the range of Λ in which your system is reversible, quasi-reversible and irreversible. Plot the CV for each case.
- e) Explain the effect of α on the electrochemical symmetry. Plot CVs to show the effect for a reversible, quasi-reversible and irreversible system.
- f) Plot and explain the effect of k_c on the system performance for the three cases of electrochemical reversibility, quasi-reversibility and irreversibility.

Hints

- a) You have to combine and simulate charge transfer by electrochemical reaction and the chemical reaction and diffusion of species. Specifically, solve the transient diffusion equation with reaction sink/source terms.
- b) Carefully calculate the characteristic and dimensionless parameters for each step involved (Refer to chapters 6 and 12, and appendix B of the book *Electrochemical methods - Fundamentals and applications* by Bard and Faulkner).