

**ÉCOLE POLYTECHNIQUE FÉDÉRALE DE LAUSANNE**  
**SGM - 6<sup>th</sup> & 8<sup>th</sup> Semester, Fall 2024**

**CAVITATION AND INTERFACE PHENOMENA**

**Chapter 4 : The Leading Edge Cavitation**



**Dr Mohamed FARHAT   Assistants: A. Sache, Th. Berger**  
**EPFL – Cavitation Research Group, Avenue de Cour 33 bis, 1007 Lausanne**

## *Cavitation Types (Reminder)*

- There are 3 types of cavitation in flowing liquids:

### 1. Bubble Cavitation

Top view of bubble cavitation on a 2D hydrofoil

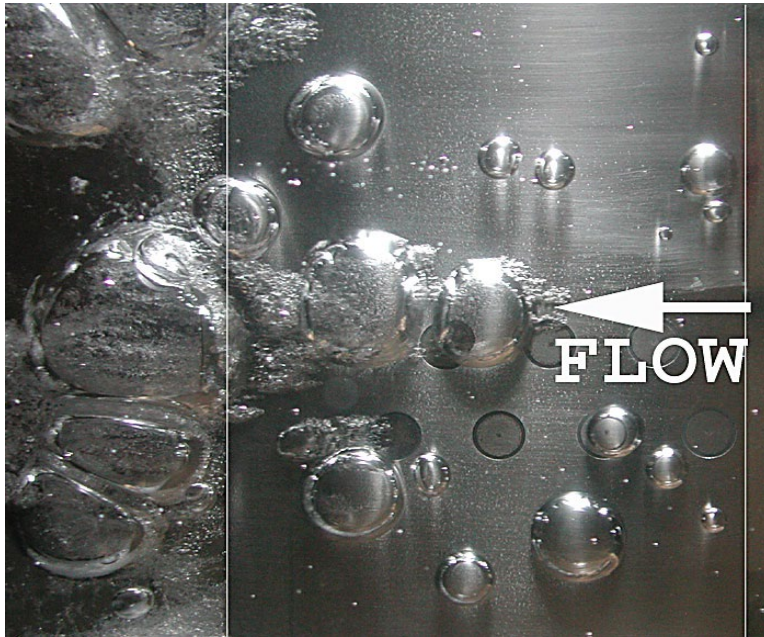

Bubble Cavitation in a marine propeller



## *Cavitation Types (Reminder)*

- There are 3 types of cavitation in flowing liquids:

### 2. Vortex Cavitation

Develops in the core of a vortex due to its low pressure

Tip vortex cavitation on an elliptical hydrofoil

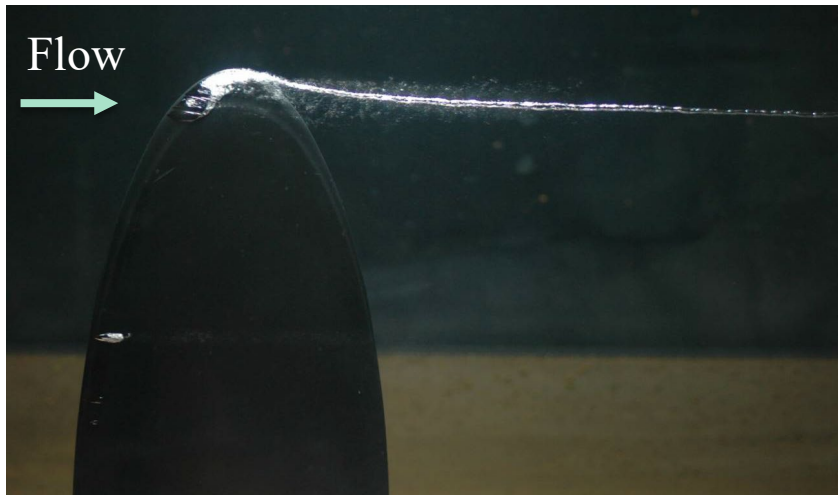

Tip vortex cavitation in a marine propeller

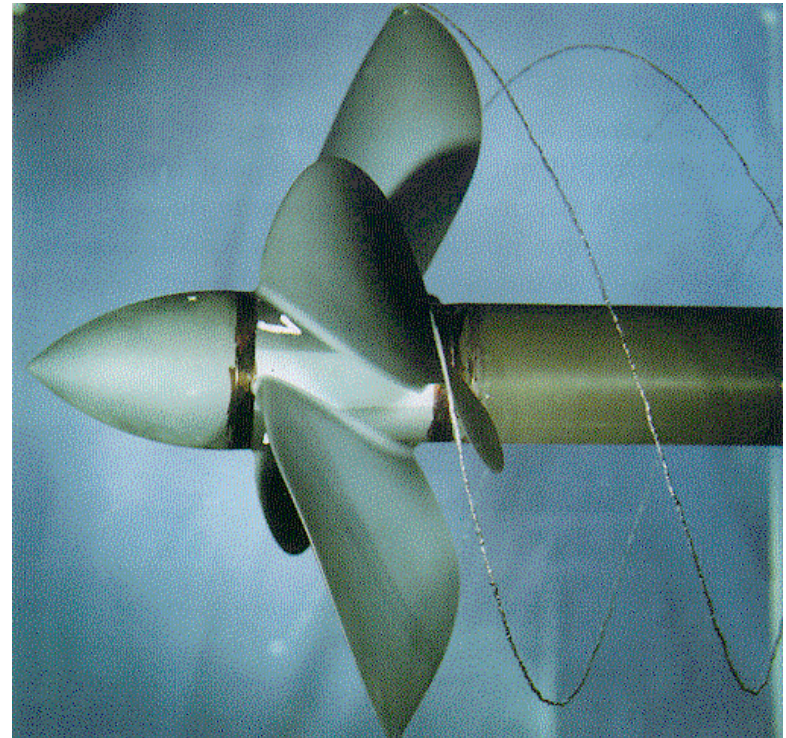

## *Cavitation Types (Reminder)*

- There are 3 types of cavitation in flowing liquids:

### 3. Leading edge cavitation

Also known as “inlet cavitation” or “attached cavitation”

Attached cavitation on a 2-D hydrofoil

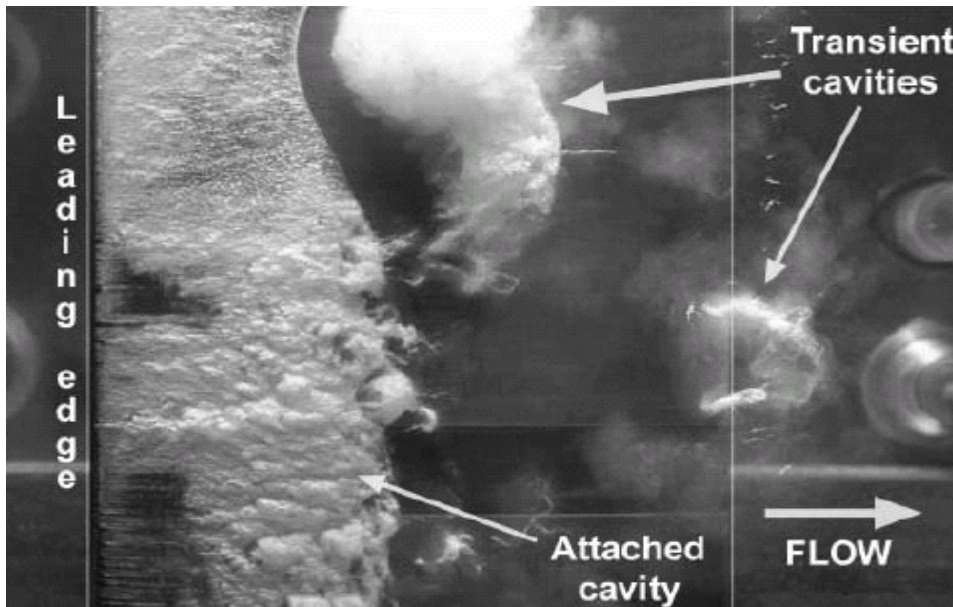

Leading edge cavitation on a pump-turbine

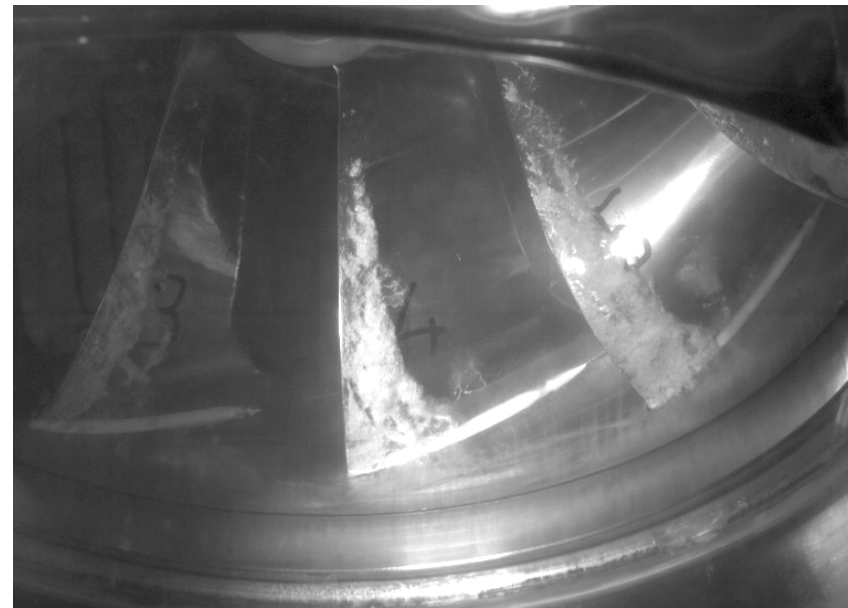

## *The Leading Edge Cavitation*

- Develops at the leading edge of a hydrofoil (blade) and extends downstream
  - The main vapor cavity may become highly unstable with a periodic shedding of transient cavities (cloud), which collapse violently downstream
- Always associated with severe erosion in the pressure recovery region

Top view of attached cavitation on a 2-D hydrofoil

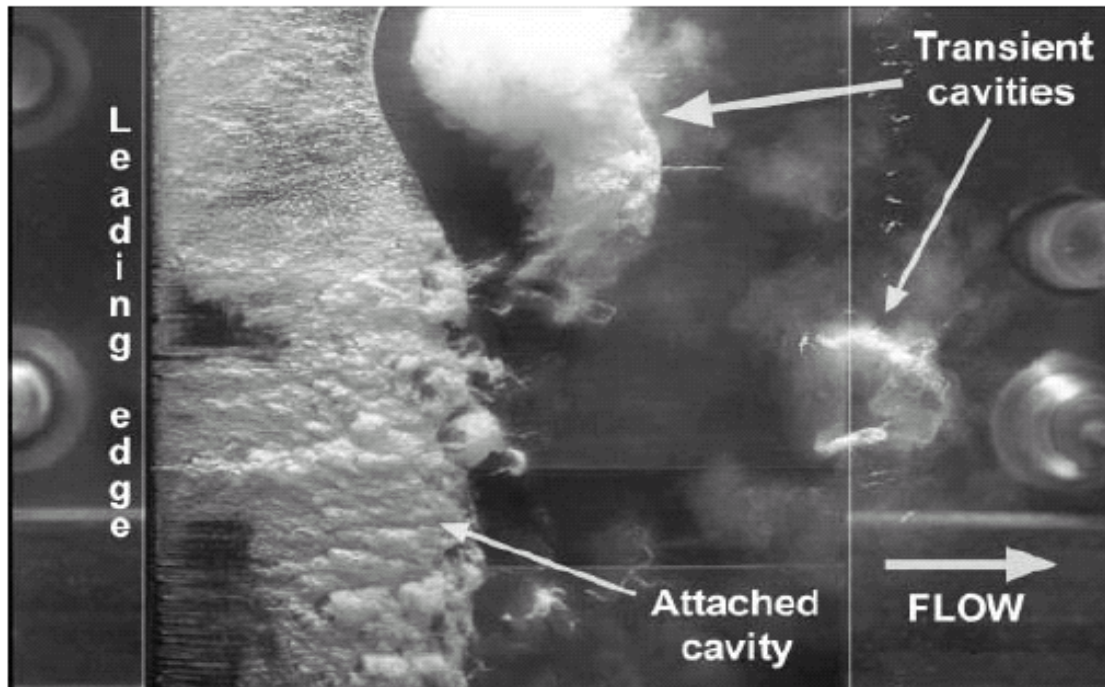

# The Leading Edge Cavitation

- Example of leading edge cavitation in model of storage pump

Leading edge cavitation in the case of a storage pump model

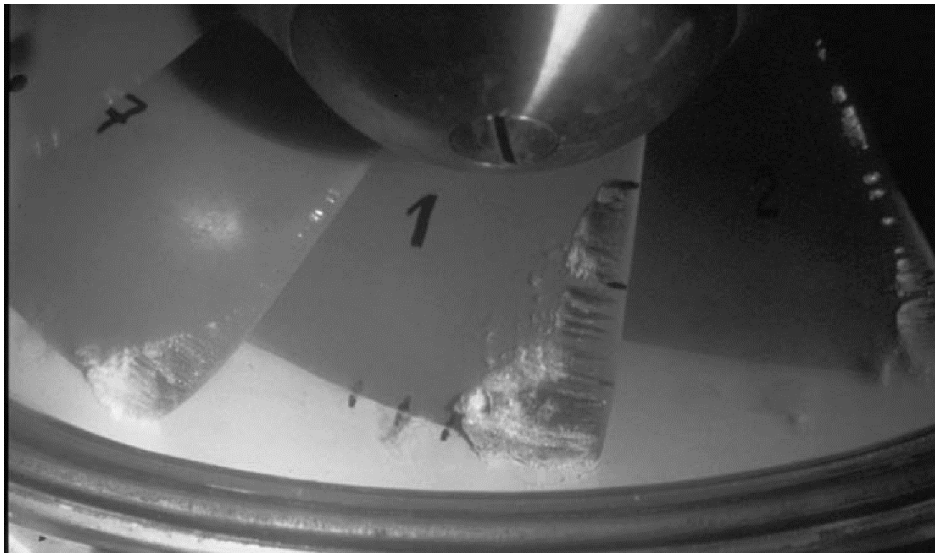

Erosion on the corresponding prototype after ~1000 hours of operation

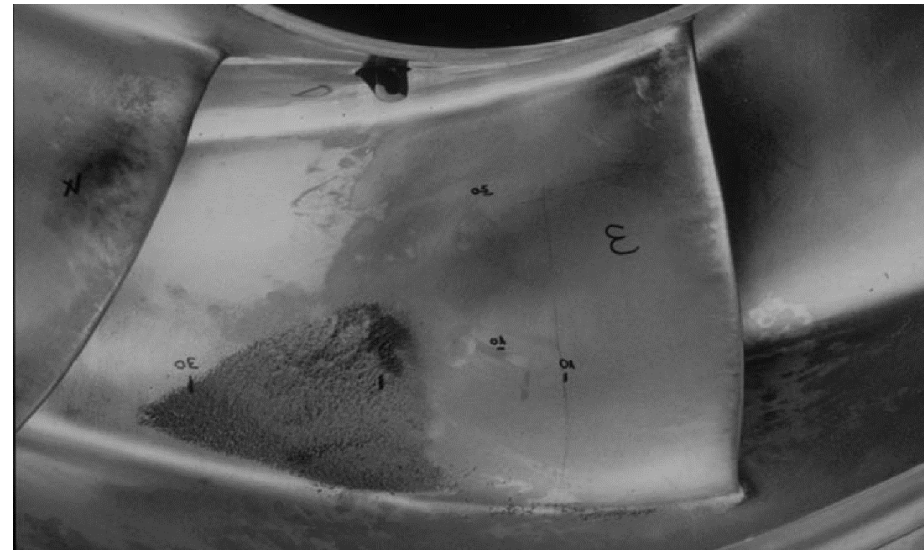

**Generation of transient cavities – Collapse in the pressure recovery region  
→ Risk of severe erosion (most erosive among all cavitation types)**

# The Leading Edge Cavitation

- Leading edge cavitation may be obtained from a smooth transition from bubble cavitation
- Local production of active nuclei
  - Surface nucleation: Growth of a nucleus fed by local vaporization
  - Non-homogeneous along the leading edge (roughness)
  - Continuous transition from bubble to attached cavitation

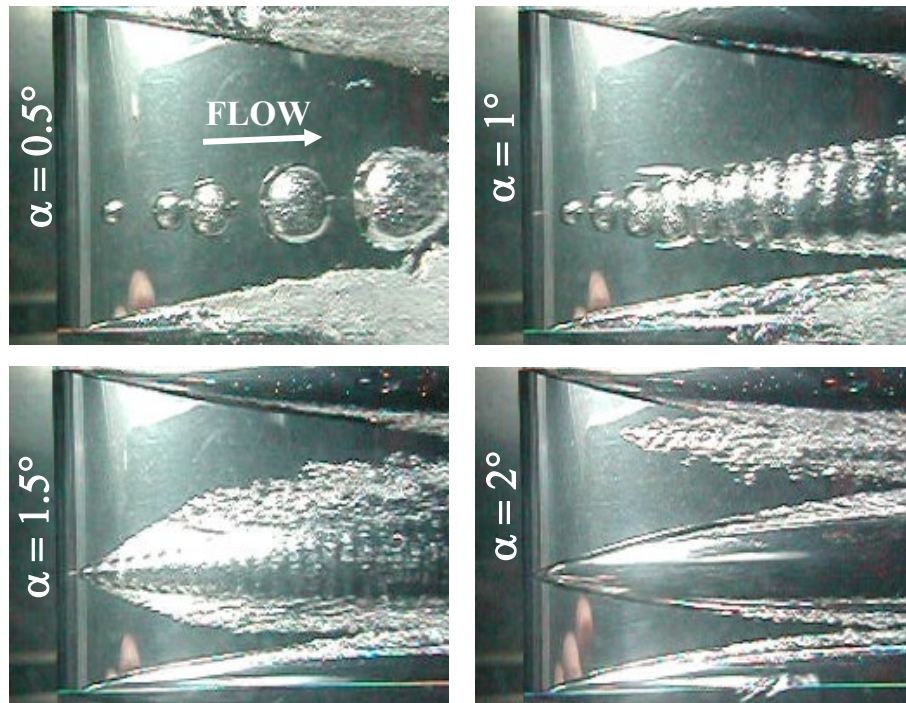

Transition bubble-to-attached cavitation through an increase of incidence angle

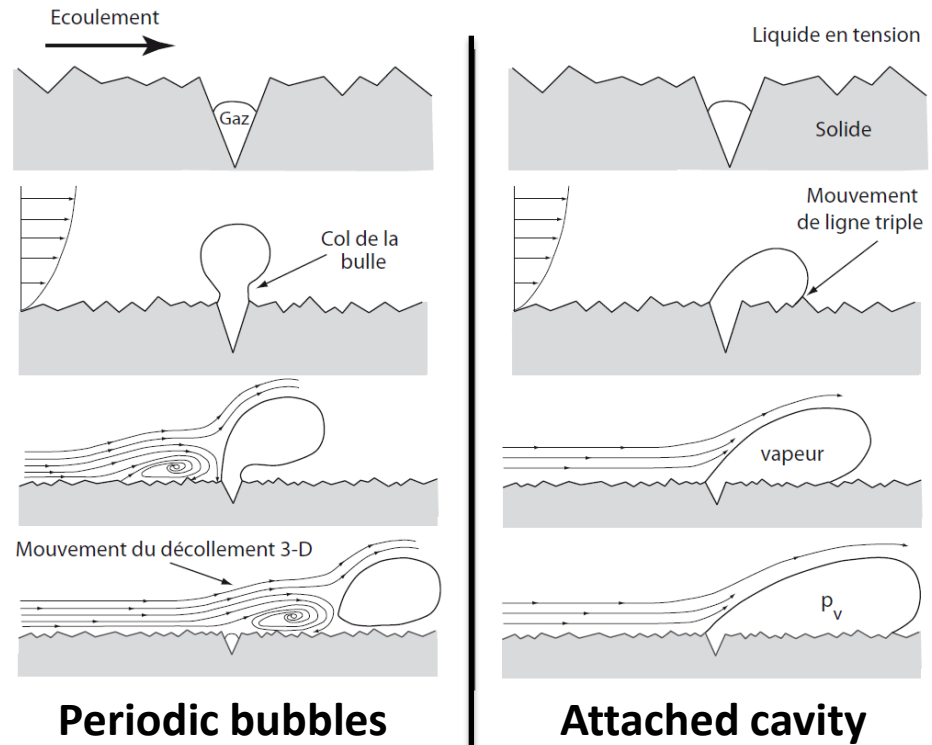

Mechanism of cavitation inception

# The Leading Edge Cavitation

- Measurement of the pressure in the vicinity of a hydrofoil leading edge
  - Piezo-resistive sensor fitted in the hydrofoil (static + dynamic pressure)
  - Sensor assembled directly in the hydrofoil (minimum geometry alteration)
  - Sensor located close to minimum pressure area ( $c_{p,min}$ )

## Mounting Procedure

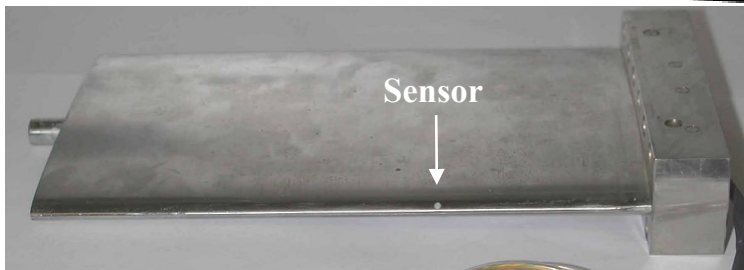
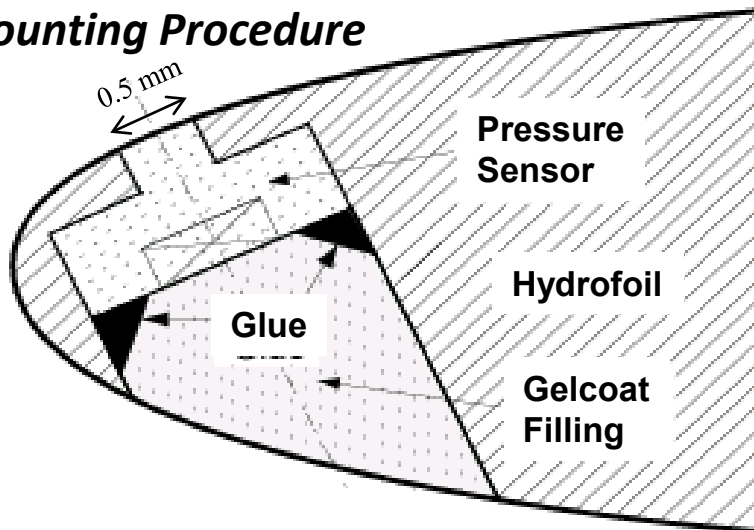

## Static calibration

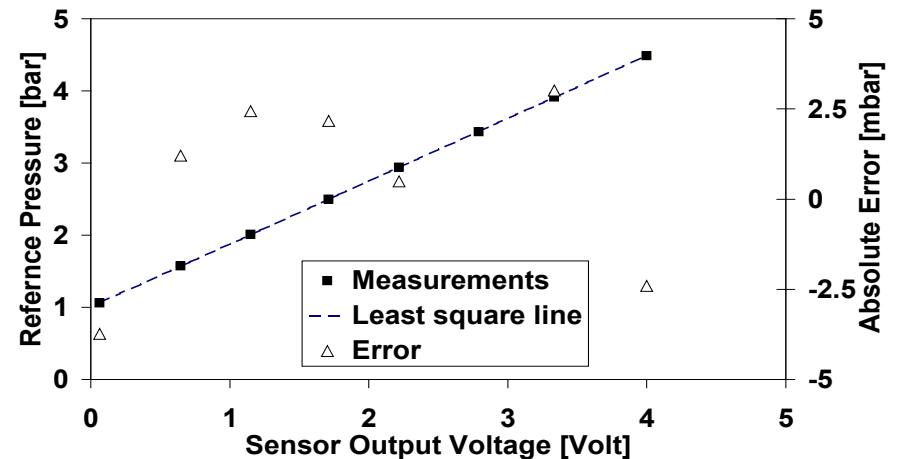

# The Leading Edge Cavitation

Cavitation Incipience - Evidence of negative pressure (Tension)  
Mean absolute pressure at the leading edge vs pressure at the test section inlet

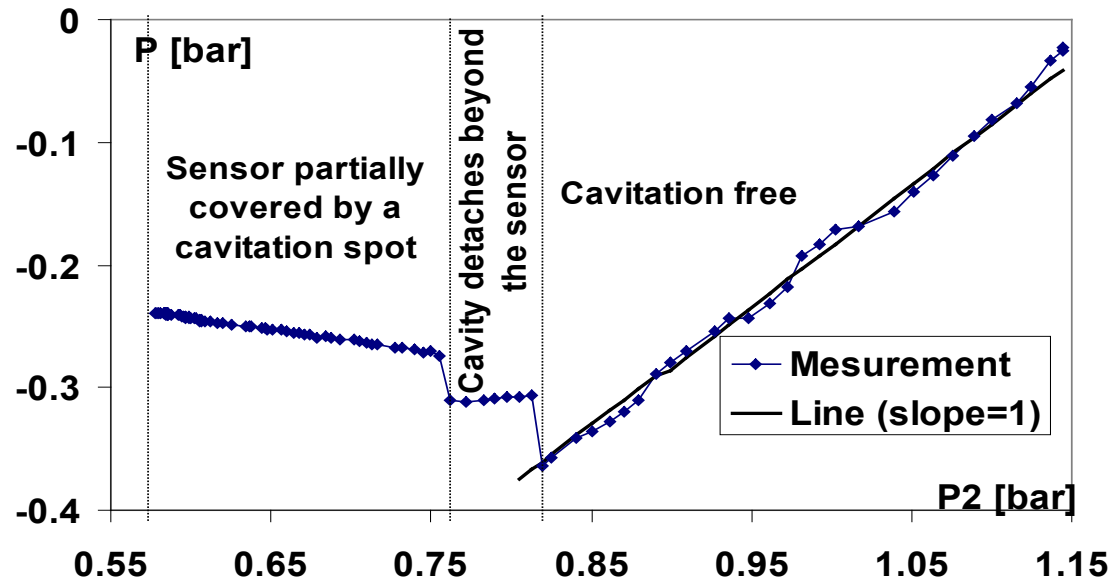

- Cavitation free regime
- Smooth hydrofoil surface & Well degassed water ( $[O_2] \lesssim 4 \text{ ppm}$ )
- Evidence of negative pressure, cavitation incipience delayed
- Onset of leading edge cavitation: Negative pressure upstream to the cavity
- Question : Is it possible to measure negative pressure with conventional sensors ?

# The Leading Edge Cavitation

## Evidence of negative pressure (Tension)

- Verification of pressure sensors response
  - Upstream velocity = 10 m/sec, Incidence =  $3^\circ$
  - Pressure at test section inlet varied from 1.8 bar to 0.7 bar and compared to the sensor response

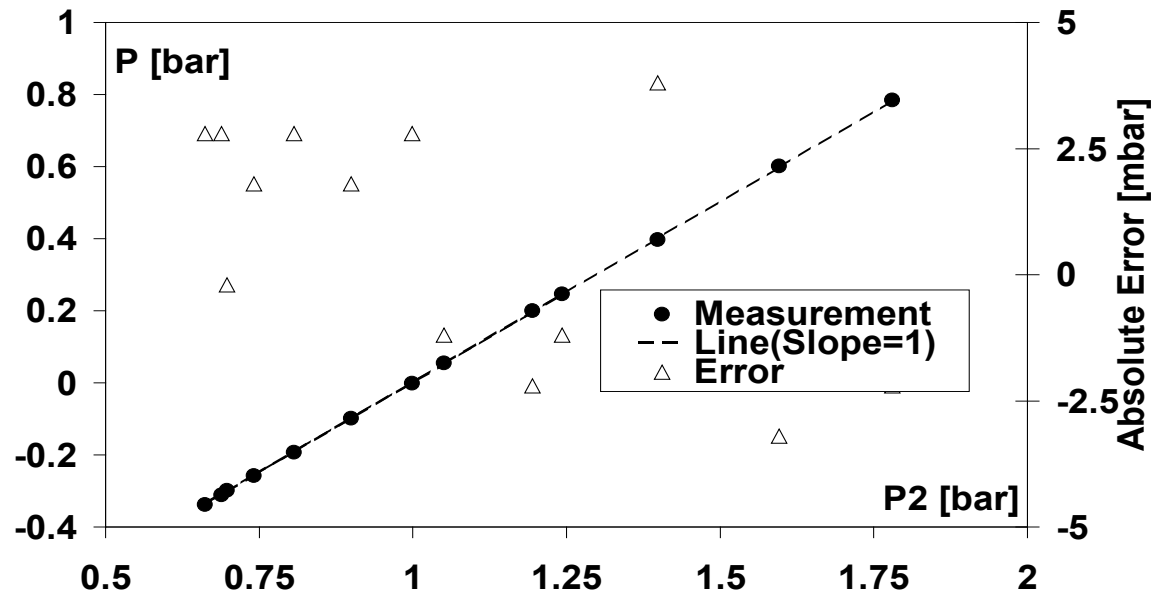

- Excellent linearity of the sensor response for negative pressure values  
→ The measurements of negative pressure are reliable.

# The Leading Edge Cavitation

- **Developed Cavitation: Measurement of the cavity dimensions**
  - Naca0009 hydrofoil, placed in the EPFL high speed cavitation tunnel
  - Laser sheet perpendicular to the hydrofoil + Side view (photography)
  - Cavity length and thickness obtained from image processing
    - Difficulties: Fluctuating 3D cavity, with non-defined border
    - Cavity length is averaged over a large number of images

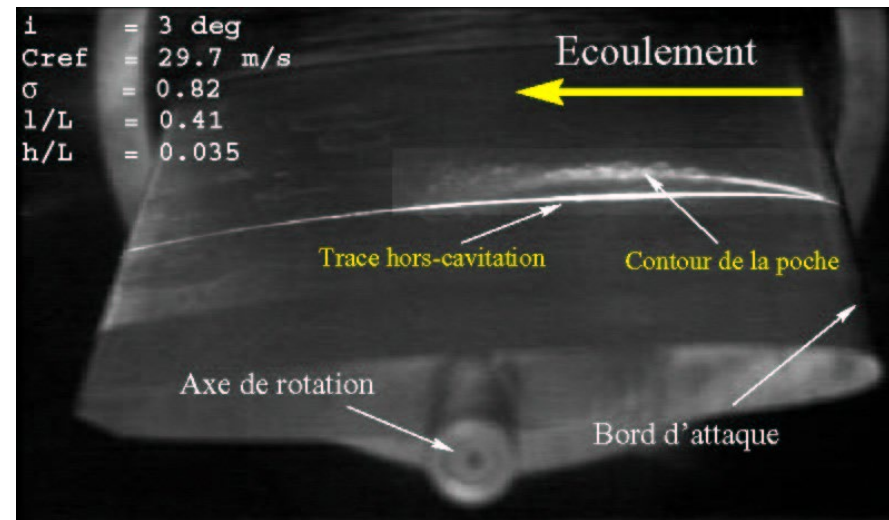
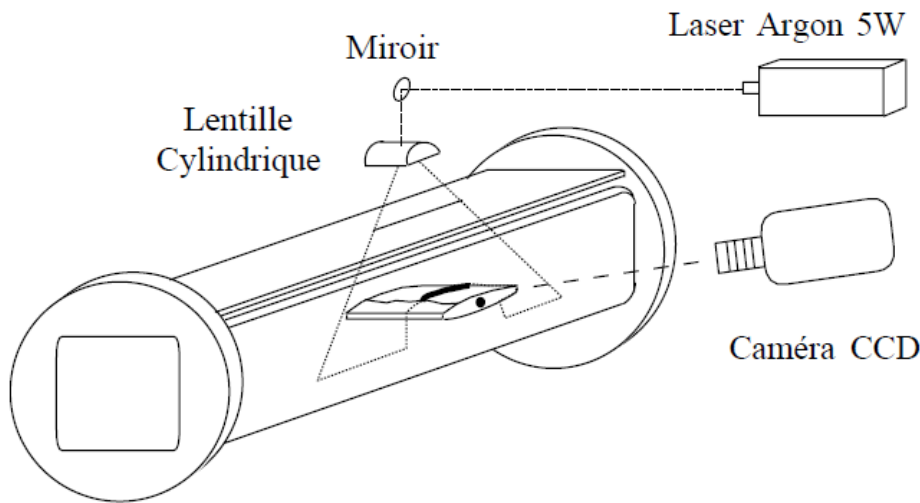

# The Leading Edge Cavitation

- Cavity thickness ( $h/c$ ) vs cavity length ( $l/c$ ),  $c$  being the chord length
  - Ratio Thickness/Length of the cavity  $\sim$  Constant

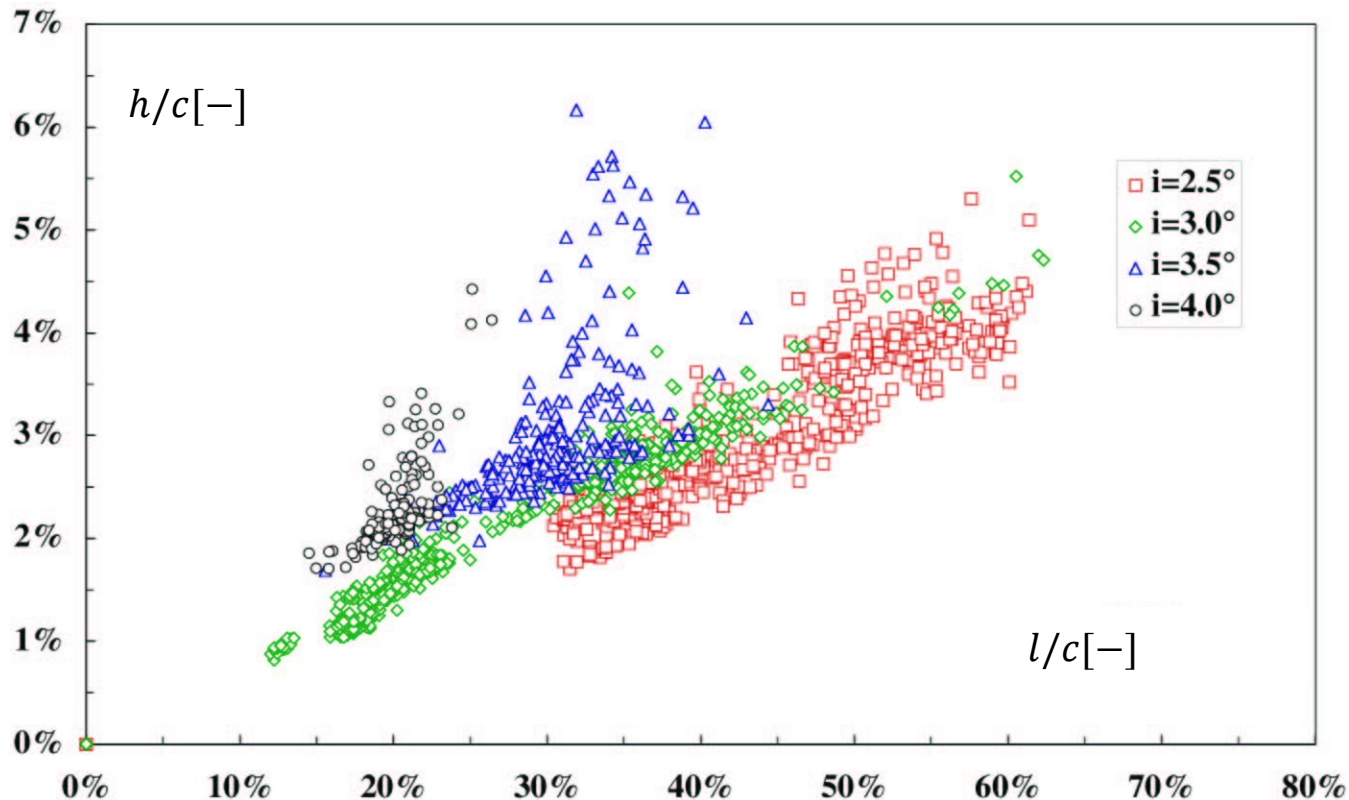

# The Leading Edge Cavitation

- Cavity length vs cavitation number ( $\sigma$ ) and incidence angle
  - Cavity length increases with incidence angle and decreases with  $\sigma$
  - Almost no effect of the flow velocity (Reynolds Nb) on the cavity length

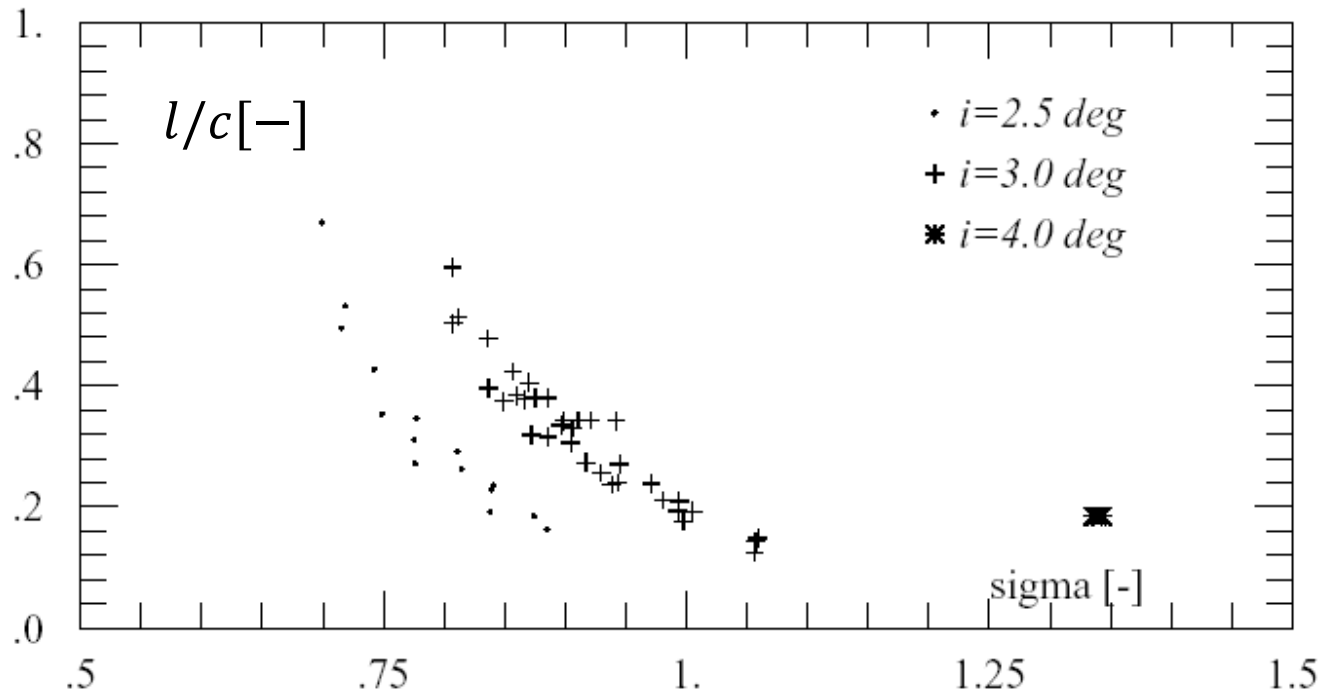

# The Leading Edge Cavitation

- Main cavity length: determined by the pressure field on the suction side
  - Hydrofoil geometry and flow conditions
- Incidence angle,  $i = i_a$ , corresponding to cavitation inception for a given  $\sigma$   
→ ~ Linear relationship
- Owing to linearized theory of leading edge cavitation (out of the scope):
  - Cavity length is function of the parameter  $\sigma/(i - i_a)$
  - Experimental validation: Unique curve of the cavity length vs the parameter  $\sigma/(i - i_a)$

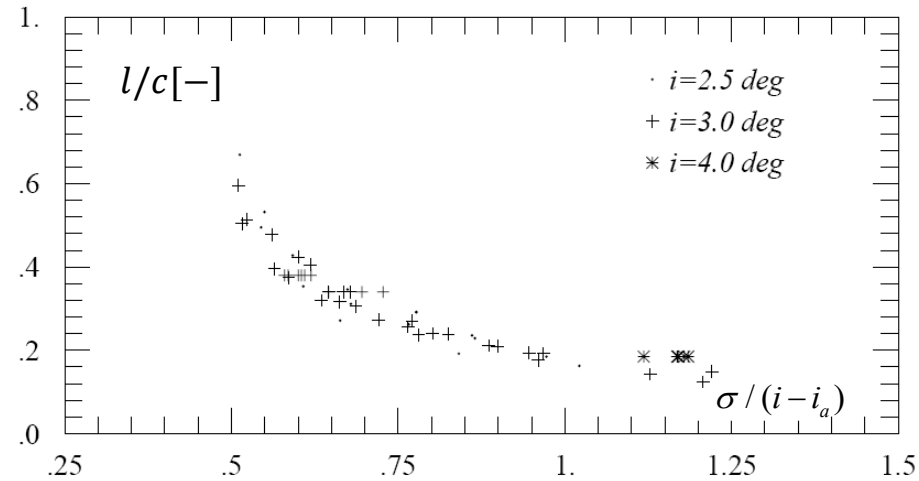
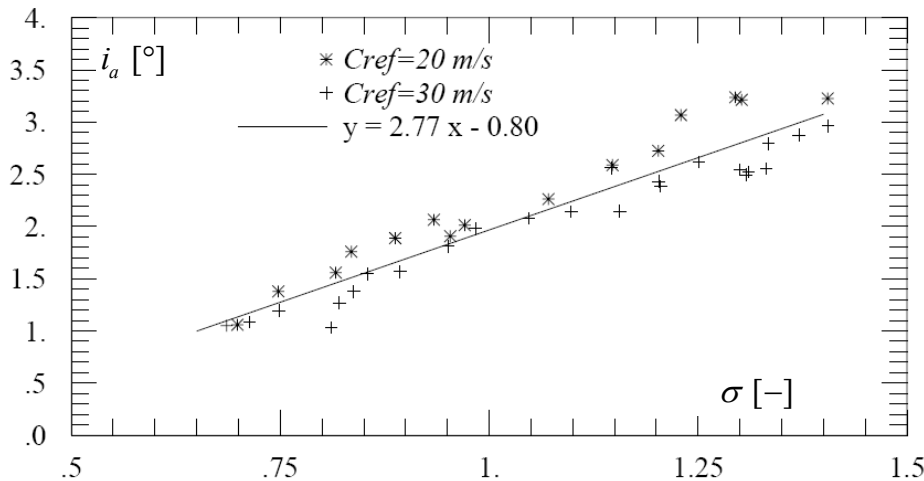

# The Leading Edge Cavitation

- Main cavity dynamics → Generation of transient cavities
  - The transient cavities are U-shaped vortices, attached to the hydrofoil surface
  - As a result, the collapses always occur close to the wall → Risk of erosion
  - Periodicity ? Shedding frequency ?

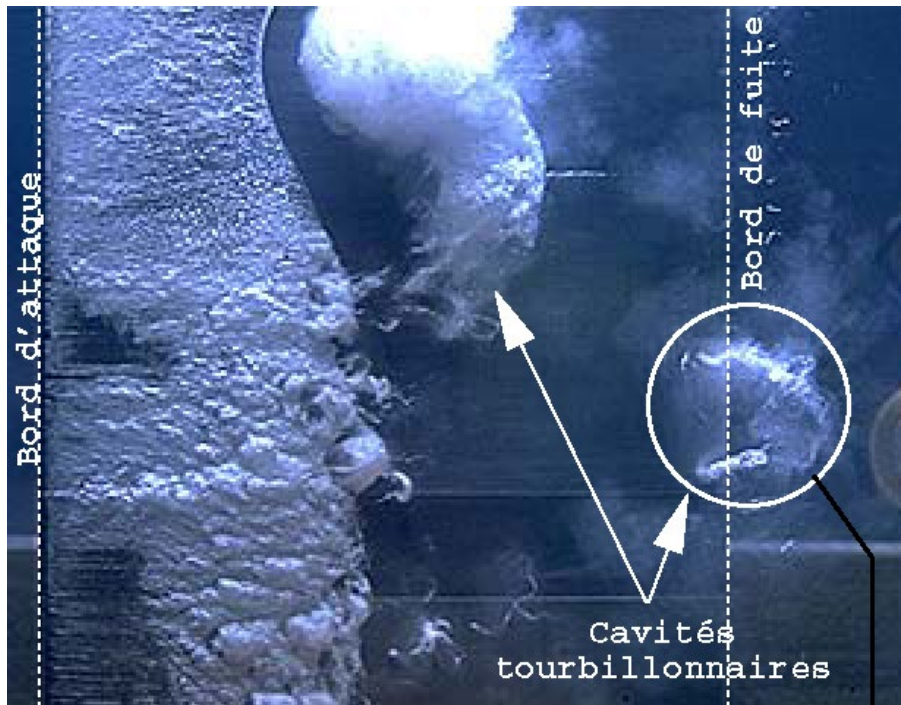

## Kelvin-Helmholtz instabilities

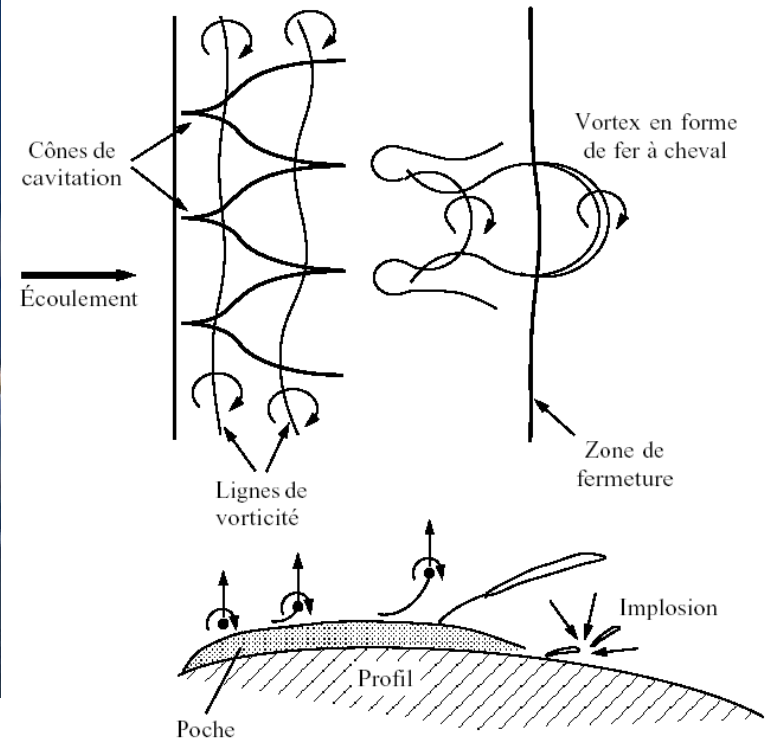

# The Leading Edge Cavitation

- Generation mechanism of transient cavities
  - Measurement of pressure fluctuation on a Naca0009 hydrofoil (suction side)
  - Instrumentation : 30 piezo resistive sensors (static and fluctuating pressure)

Specific procedure for sensors implementation:

- Sensors ( $\varnothing 3$  mm x 1 mm) embedded in the hydrofoil (assembled in pre-drilled chambers)
  - The cavity is then filled with silicone compound for sensor protection
    - *If the cavity is left filled with water  $\rightarrow$  Local cavitation can destroy the sensor*
- $\rightarrow$  Almost no alteration of the hydrofoil geometry

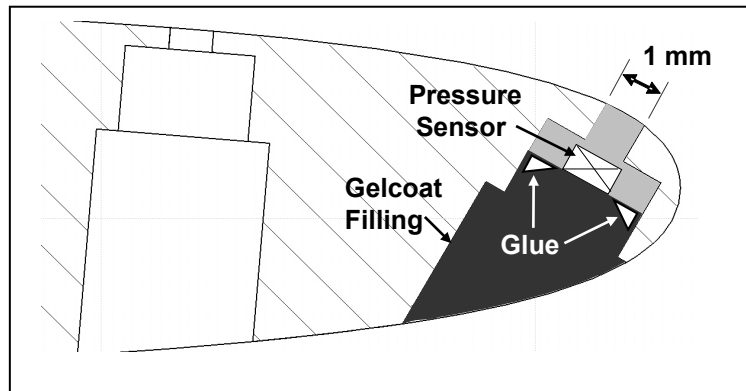

Sensors are flush-mounted on the suction side

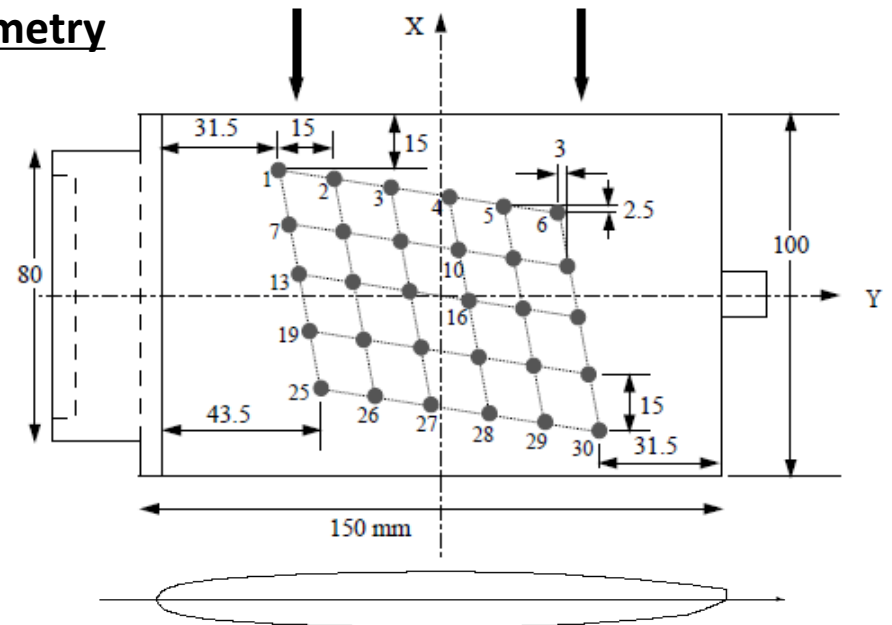

# The Leading Edge Cavitation

- **Forced oscillation of the main cavity:**

- Hydrofoil resonance: Kàrman vortices in the wake  
Shedding freq.  $\sim$  Resonance freq. (1st torsional mode)
- Interactions : Cavity  $\leftrightarrow$  Vortices  $\leftrightarrow$  Mechanical structure

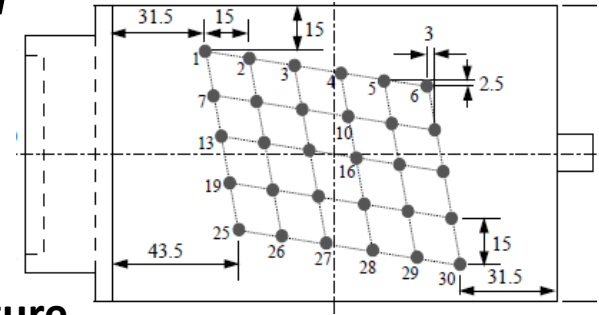

- Broadband signals of pressure fluctuation
  - Resonance signature is visible on all sensors

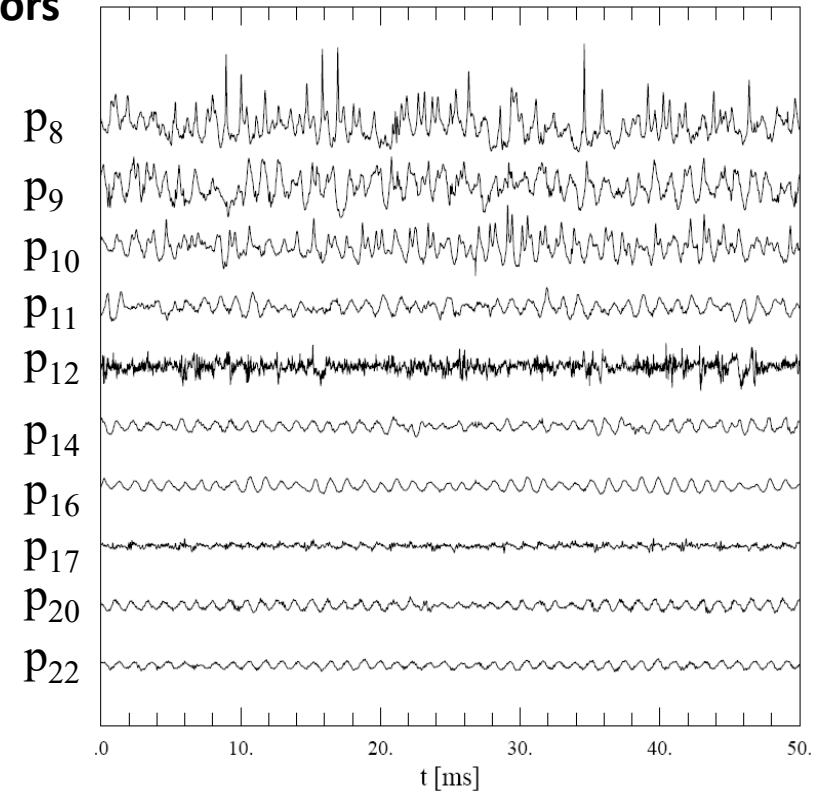
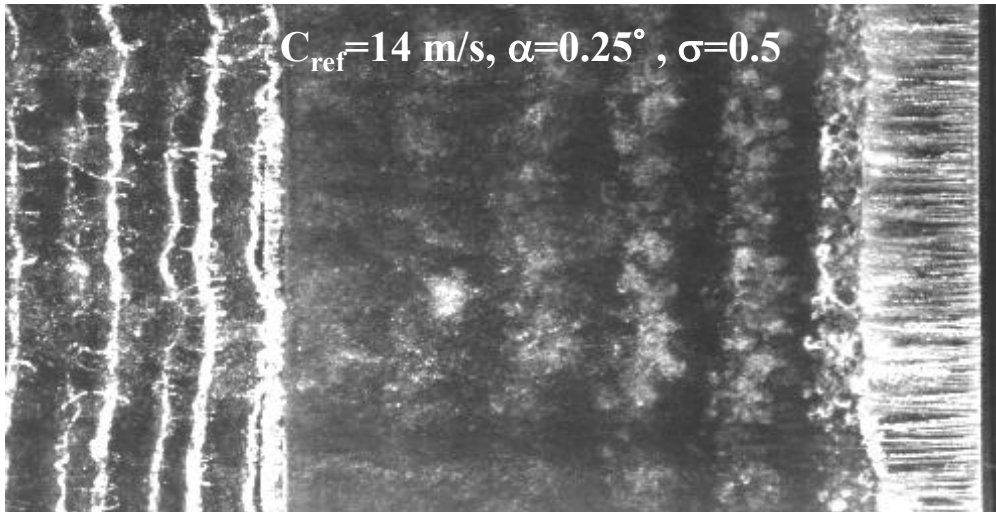

# The Leading Edge Cavitation

- Forced oscillation of the main cavity**

- Hydrofoil resonance: Kàrman vortices in the wake  
Shedding freq.  $\sim$  Resonance freq. (1st torsional mode)
- Interactions : Cavity  $\leftrightarrow$  Vortices  $\leftrightarrow$  Mechanical structure

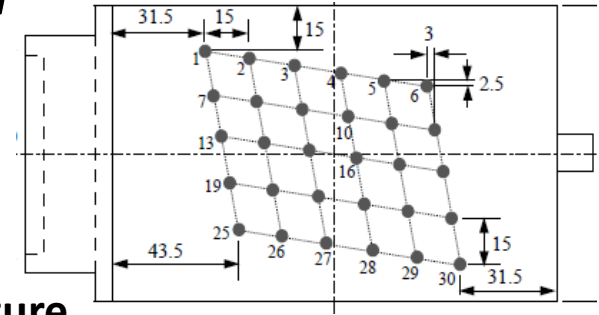

- Pressure spectra at cavity closure ( $p_8, p_9, p_{10}$ ):
  - Main frequency: Karman shedding frequency
  - Frequency (Karman)  $\sim$  Resonance Freq. (foil)  
(1<sup>st</sup> torsional mode :  $\sim 900$  Hz)

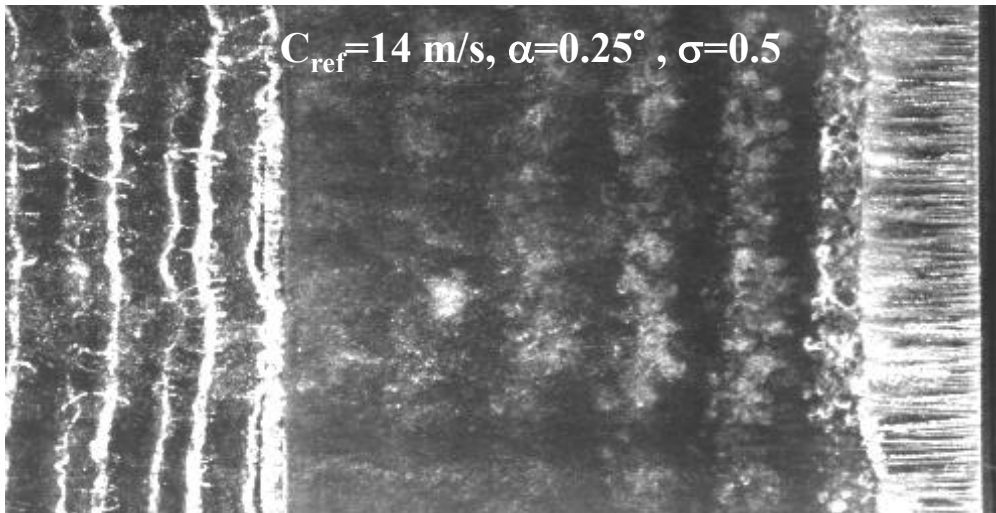
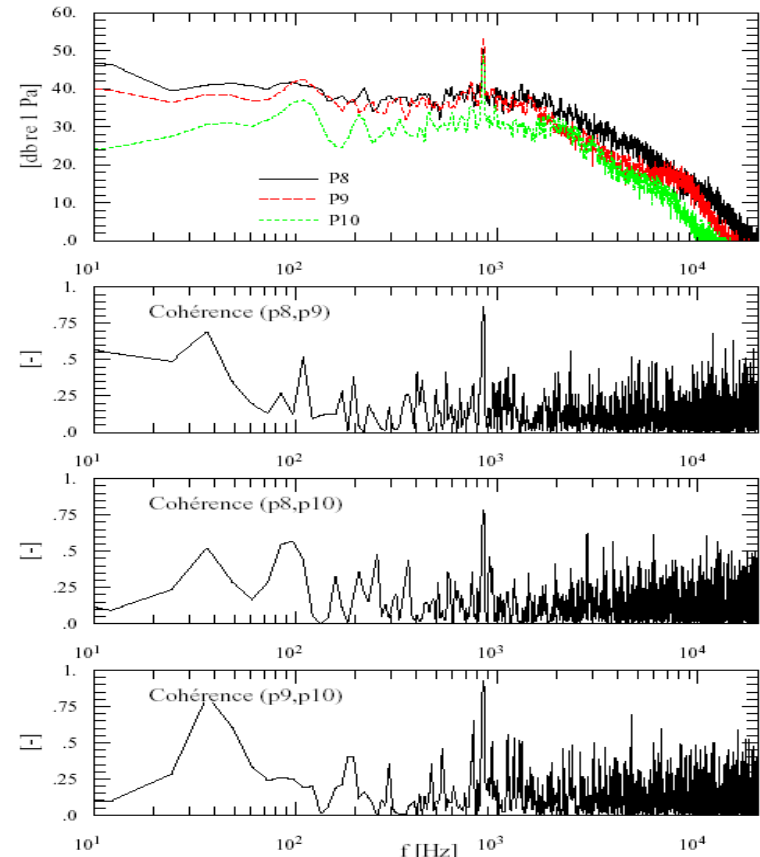

# The Leading Edge Cavitation

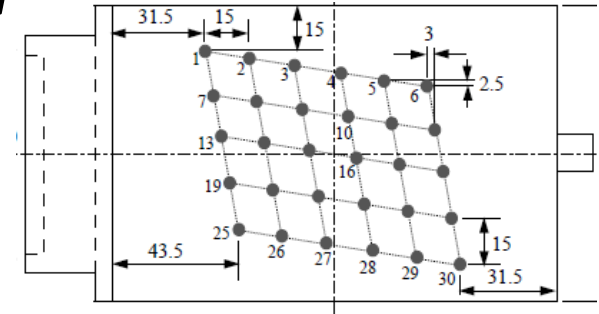

- **Free oscillation of the main cavity:**

- **Stable cavitation:**

- Transient cavities: small, compared to main cavity length
- Maximum fluctuation at the cavity closure

$$C_{ref} = 14 \text{ m/s}, \alpha = 3^\circ, \sigma = 1.2$$

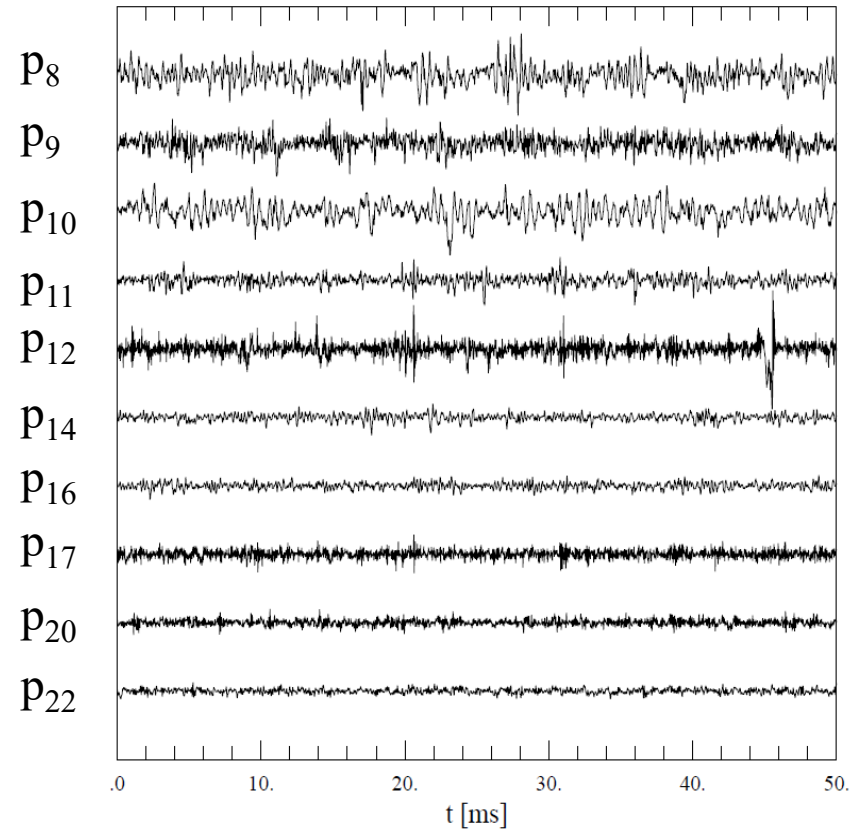
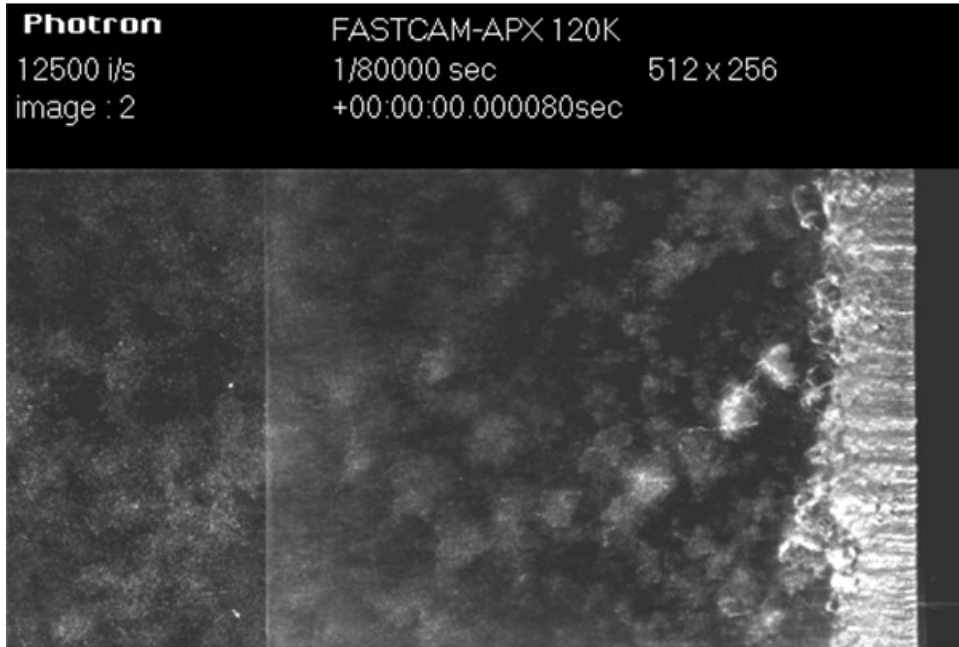

# The Leading Edge Cavitation

- **Free oscillation of the main cavity:**
  - Stable cavitation:
    - Spectra of pressure fluctuation @ cavity closure
    - No clear dominant frequency: Random shedding

$$C_{ref} = 14 \text{ m/s}, \alpha = 3^\circ, \sigma = 1.2$$

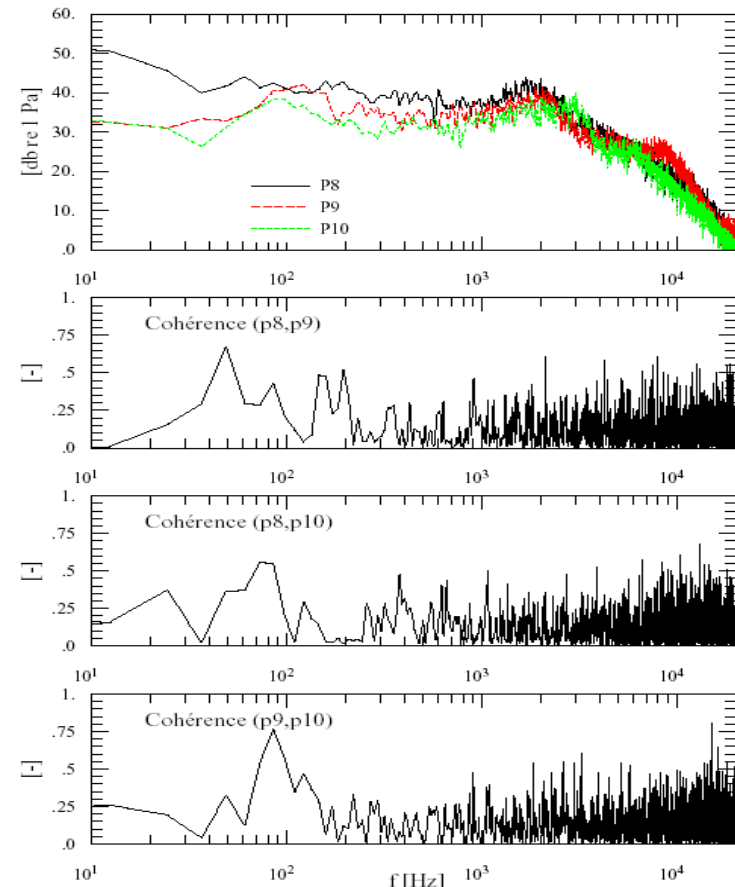
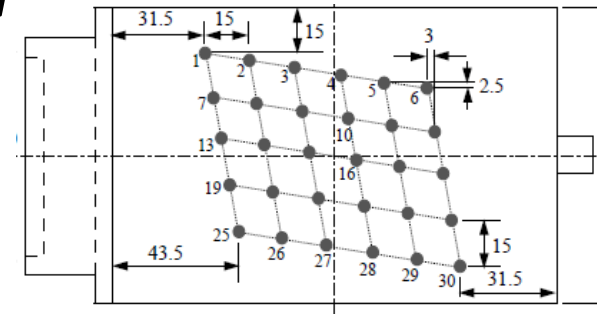
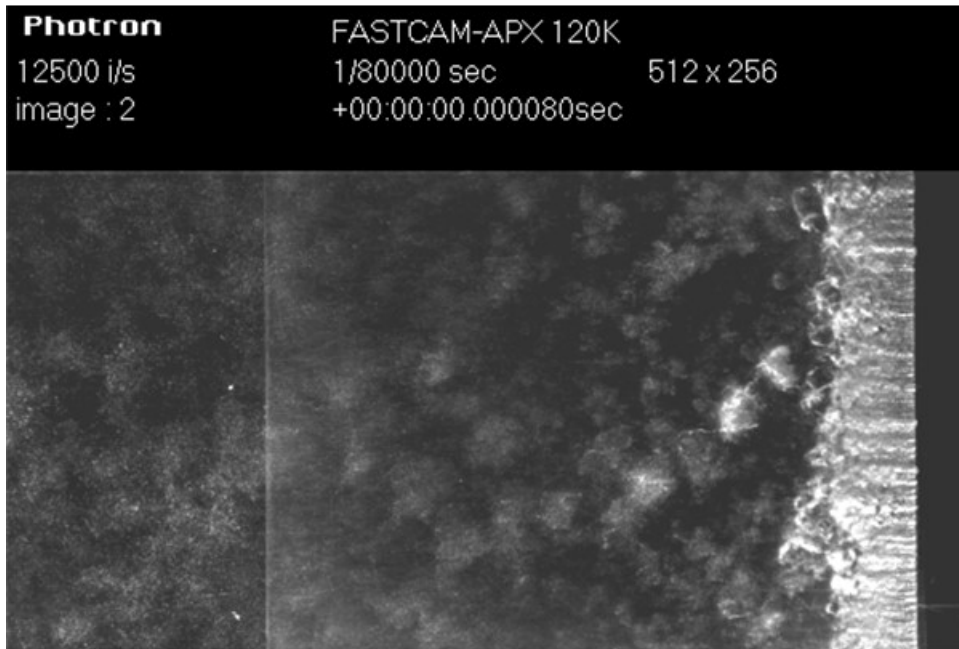

# The Leading Edge Cavitation

- **Free oscillation of the main cavity:**
  - **Stable cavitation:**
    - Time-frequency analysis of pressure fluctuation
    - shedding strongly intermittent

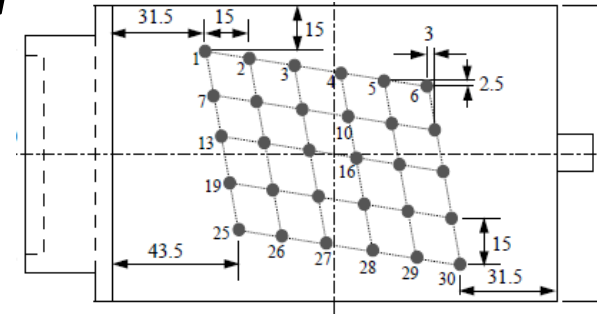

$$C_{ref} = 14 \text{ m/s}, \alpha = 3^\circ, \sigma = 1.2$$

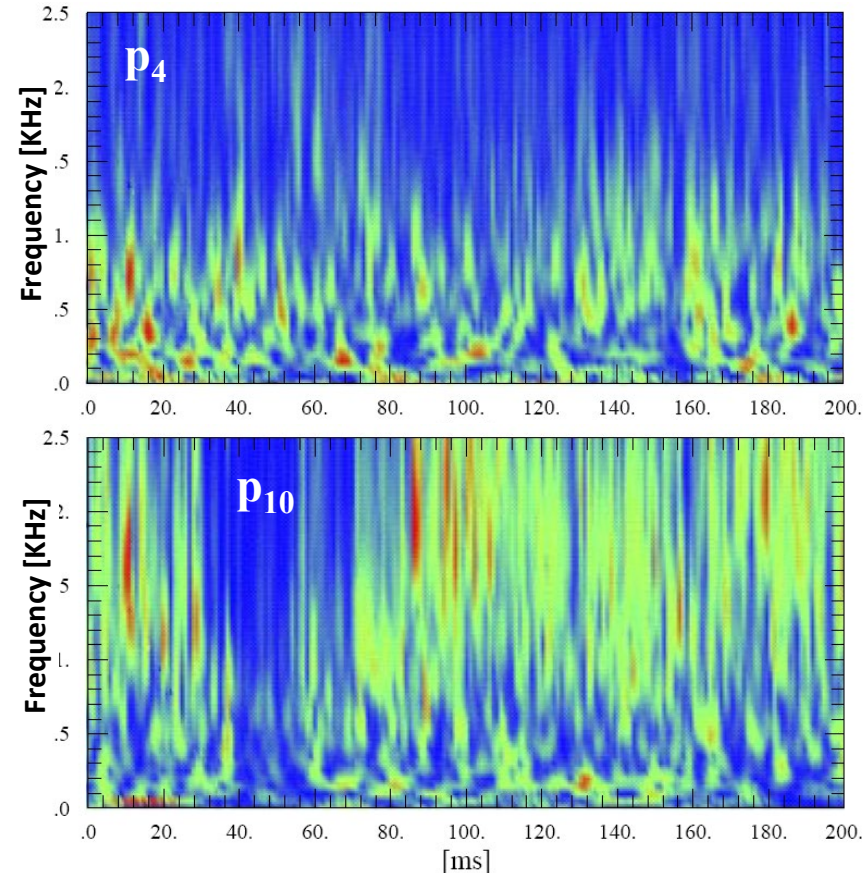
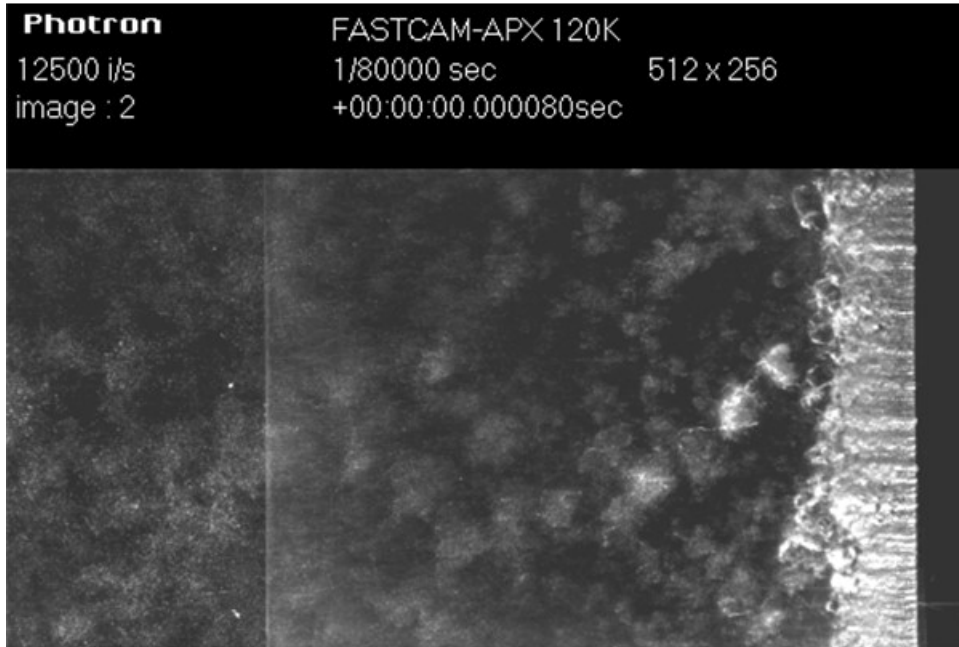

# The Leading Edge Cavitation

- **Free oscillation of the main cavity:**

- **Unstable cavitation (cloud cavitation):**

- Size of transient cavities similar to the main cavity length
- Maximum fluctuation at the main cavity closure

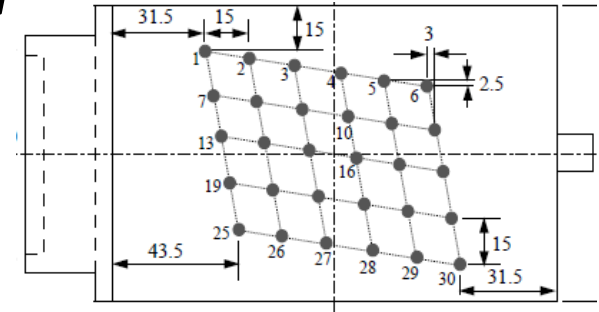

$C_{ref}=14 \text{ m/s}, \alpha=4.5^\circ, \sigma=1.2$

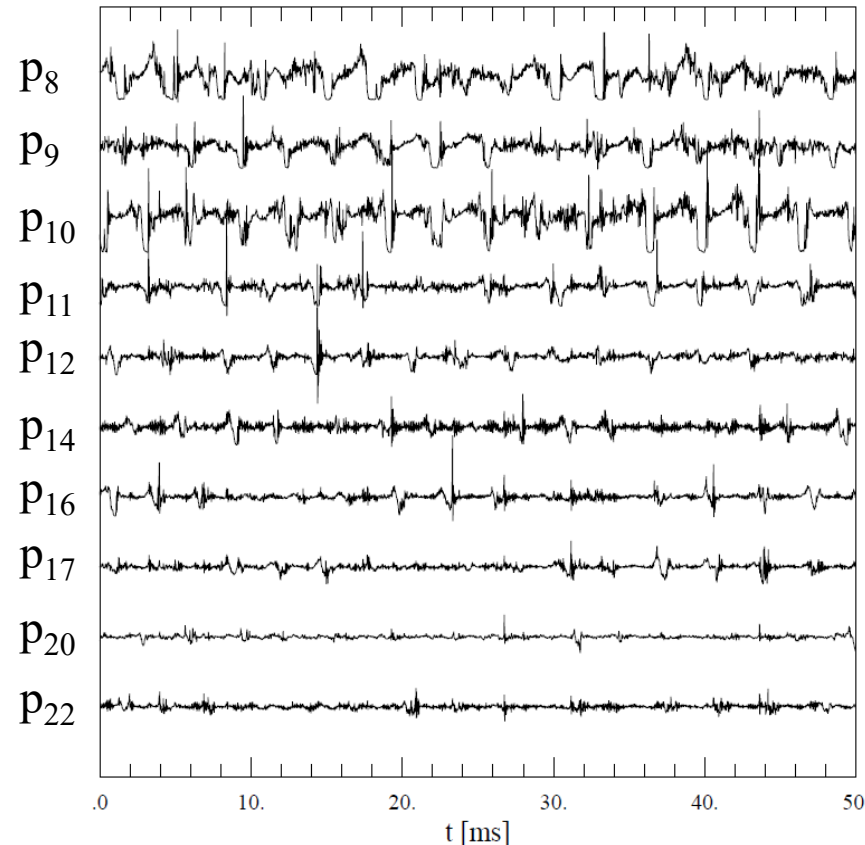
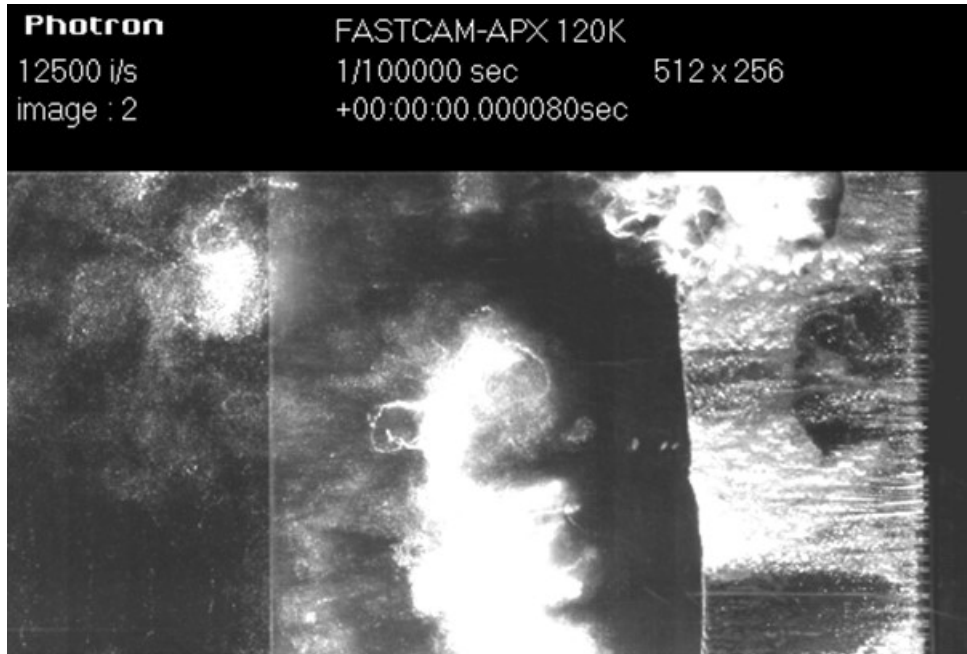

# The Leading Edge Cavitation

- **Free oscillation of the main cavity**
  - Unstable cavitation (cloud cavitation):
    - Pressure spectra at the main cavity closure
    - Periodic shedding of transient cavities

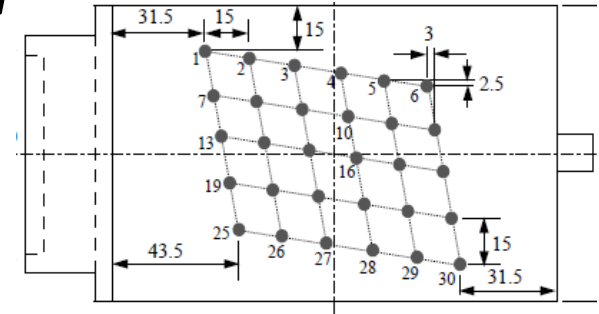

$$C_{ref} = 14 \text{ m/s}, \alpha = 4.5^\circ, \sigma = 1.2$$

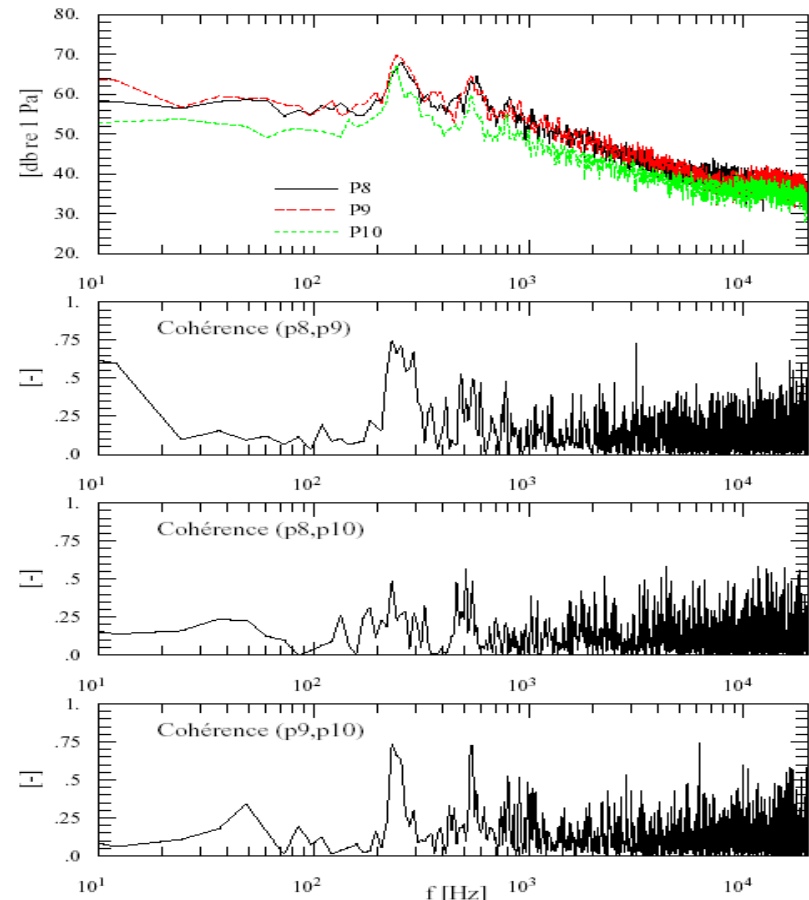
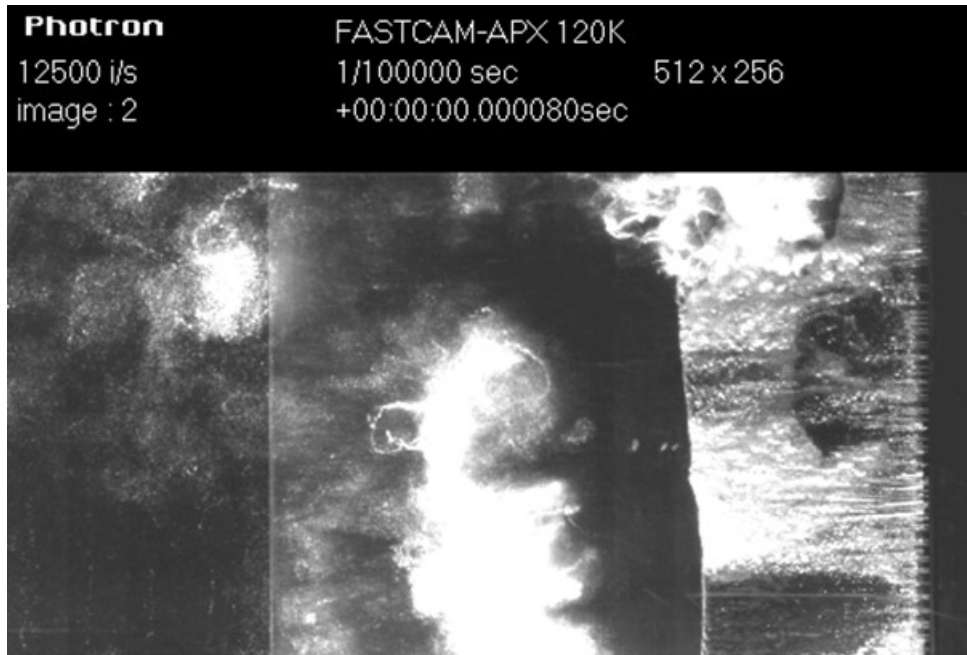

# The Leading Edge Cavitation

- **Free oscillation of the main cavity:**
  - Unstable cavitation (cloud cavitation):
    - Time-Frequency analysis of pressure fluctuation at the main cavity closure
    - regular shedding of transient cavities

$$C_{ref} = 14 \text{ m/s}, \alpha = 4.5^\circ, \sigma = 1.2$$

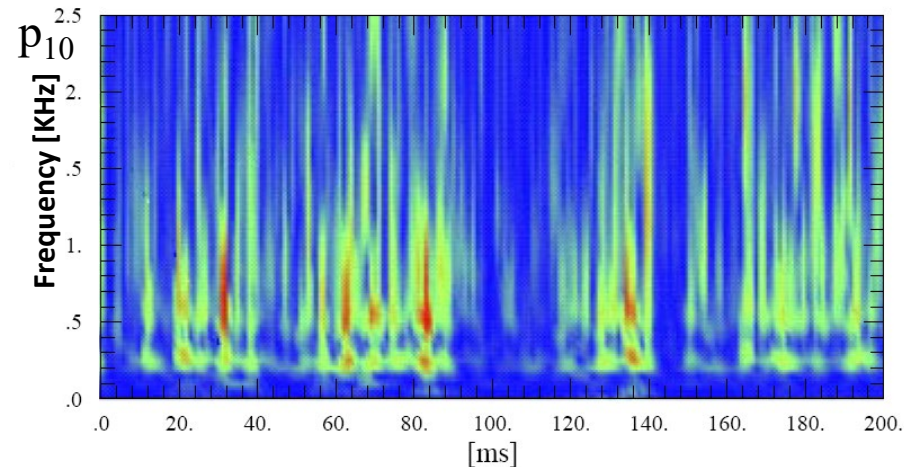
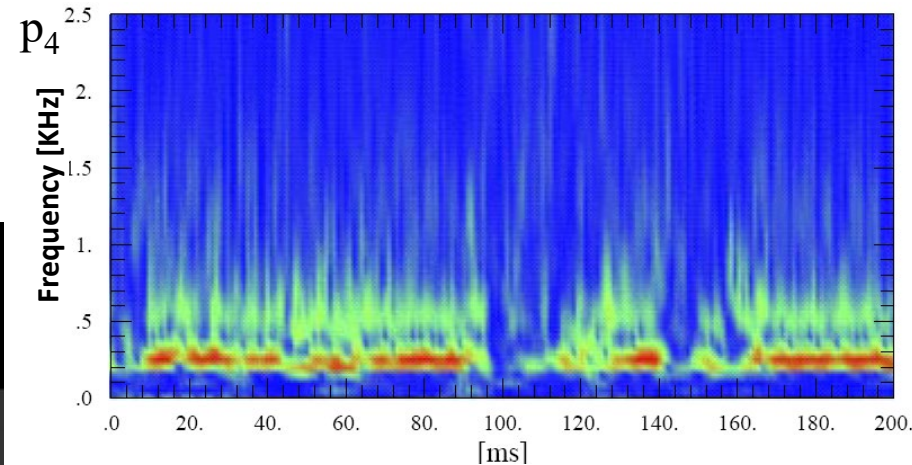
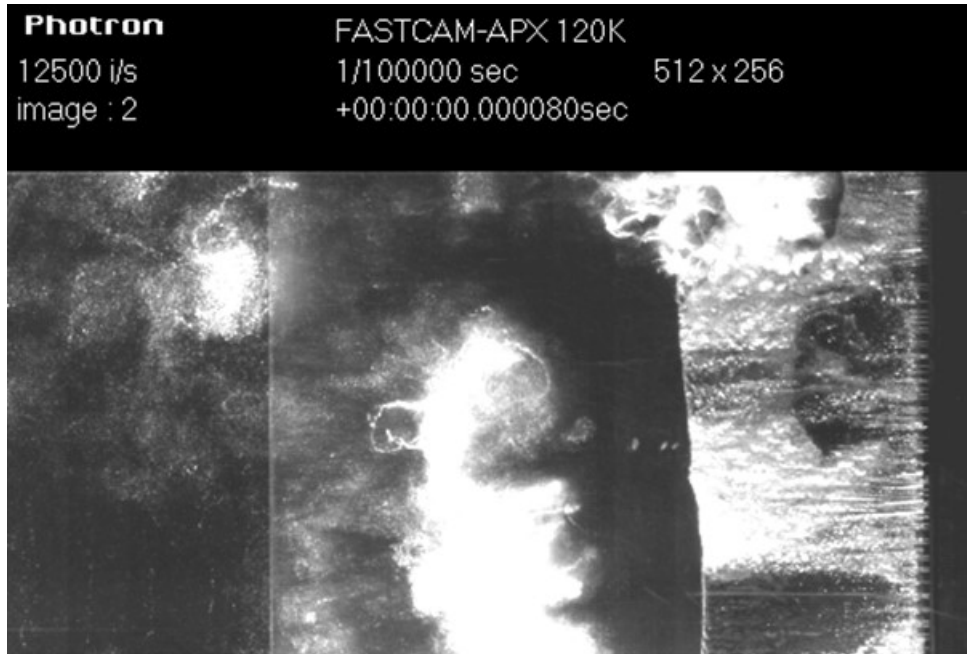
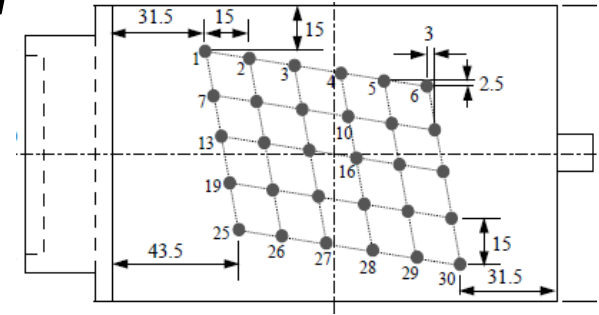

# The Leading Edge Cavitation

- Case of unstable cavitation (Cloud cavitation)
  - The shedding frequency ( $f$ ) follows a Strouhal like law:

$$St = \frac{fL_{cavity}}{C_{ref}}$$

Where  $L_{cavity}$  is the main cavity length (average),  $C_{ref}$  is the upstream velocity

- For a given geometry, the Strouhal Nb depends slightly on the incidence

Incidence [°]	Nombre de Strouhal
3.0	0.23
3.5	0.29
4.0	0.32

# The Leading Edge Cavitation

- Physical mechanism of unstable (cloud) cavitation:
  - A periodic phenomenon
  - At the cavity closure:
    - Increase of the pressure (stagnation point)  
→ Re-entrant jet
  - The jet moves backward beneath the cavity
  - Part of the main cavity is convected by the flow
  - Collapse of the bubbles cloud in the pressure recovery region and the main cavity regenerates

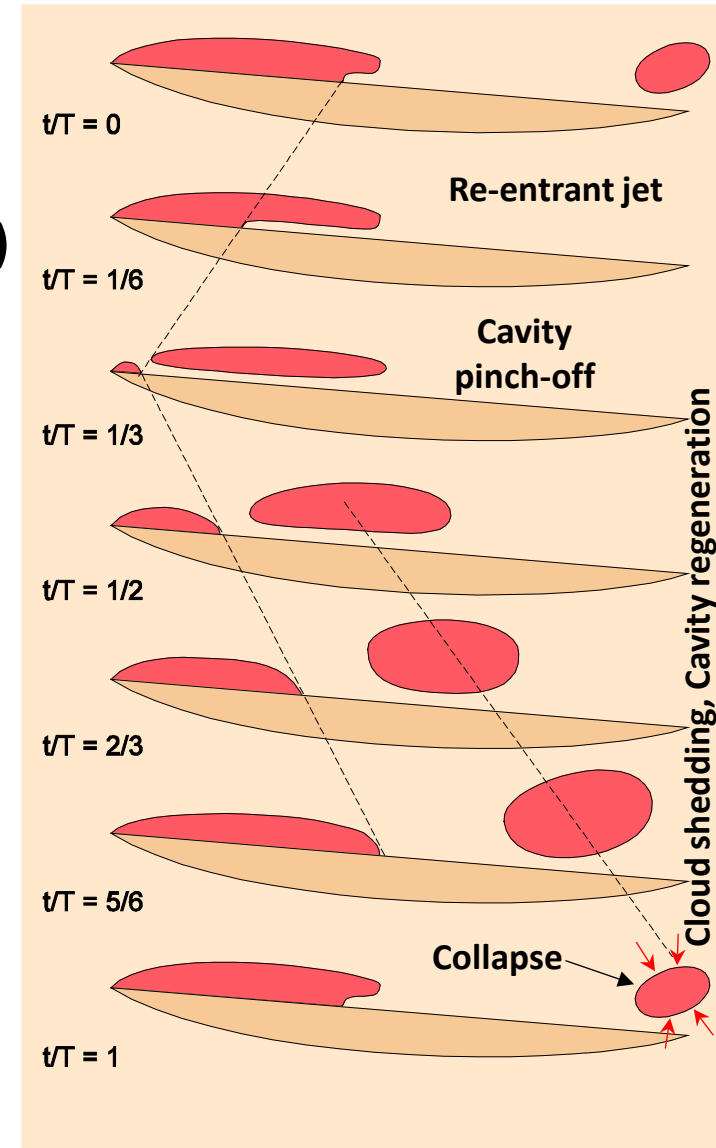
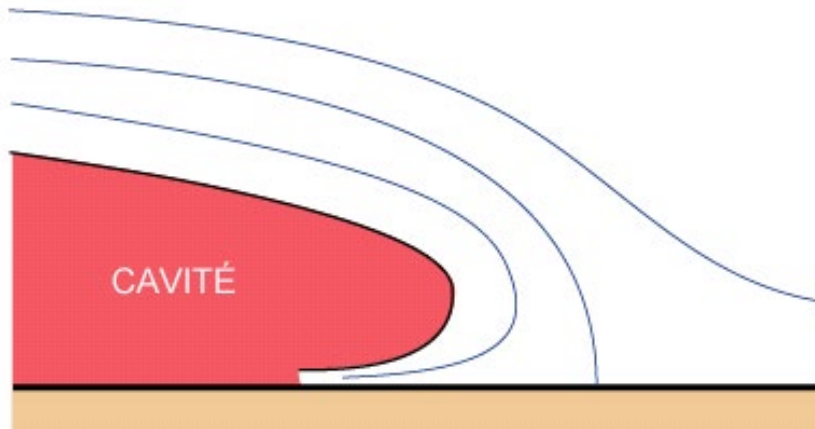

# ***The Leading Edge Cavitation***

- **Transition from stable to unstable leading edge cavitation ?**
  - **How and when sheet cavitation turns into cloud cavitation ?**
  - **The transition between these 2 types of cavitation is not fully understood**
- **It is well known that sheet cavitation may switch cloud cavitation when one of the following parameters is increased beyond a threshold value:**
  - **Reynolds number,**
  - **Incidence angle,**
  - **Turbulence level (leading edge roughness)**
- **It is not possible nowadays to predict the transition to cloud cavitation.**

# The Leading Edge Cavitation

- Stable to unstable transition of leading edge cavitation ?
  - Recent reports\* : Transition to cloud cavitation may be due to condensation shock waves because of a supersonic flow inside the liquid-gas mixture
  - Experimental procedure: High-frequency X-Ray densitometry (1 kHz)

$$\alpha = \frac{\ln\left(\frac{I_m}{I_w}\right)}{\ln\left(\frac{I_a}{I_w}\right)}$$

$\alpha$ : void fraction,  $I$ : Beam intensity  
 $w$ : water,  $a$ : air,  $m$ : liquid-gas mixture

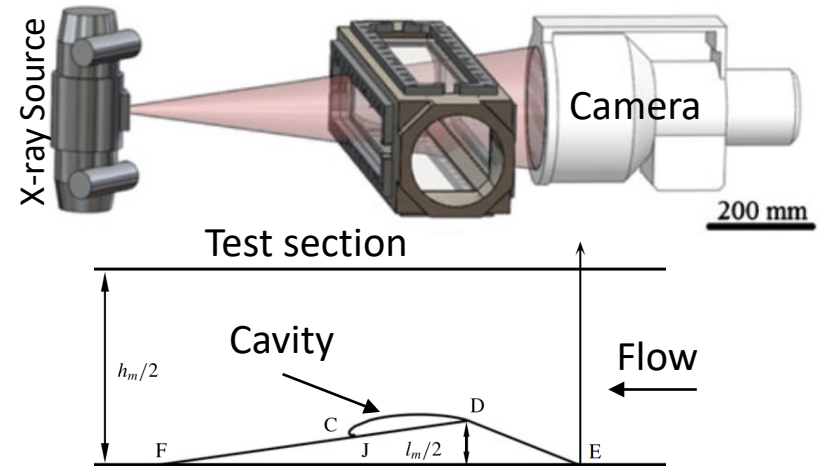
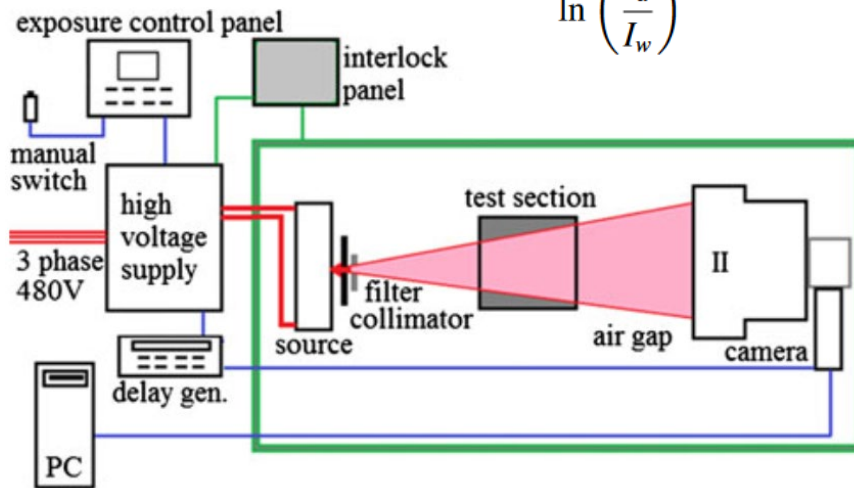

\* H. Ganesh et al., "Bubbly shock propagation as a mechanism for sheet-to-cloud transition of partial cavities », *JFM*, 2016

# The Leading Edge Cavitation

- Stable to unstable transition of leading edge cavitation ?

Time series of X-ray densitometry-based void fraction for  $\sigma_0 = 1.95$  and  $U_0 = 8 \text{ m s}^{-1}$ \*

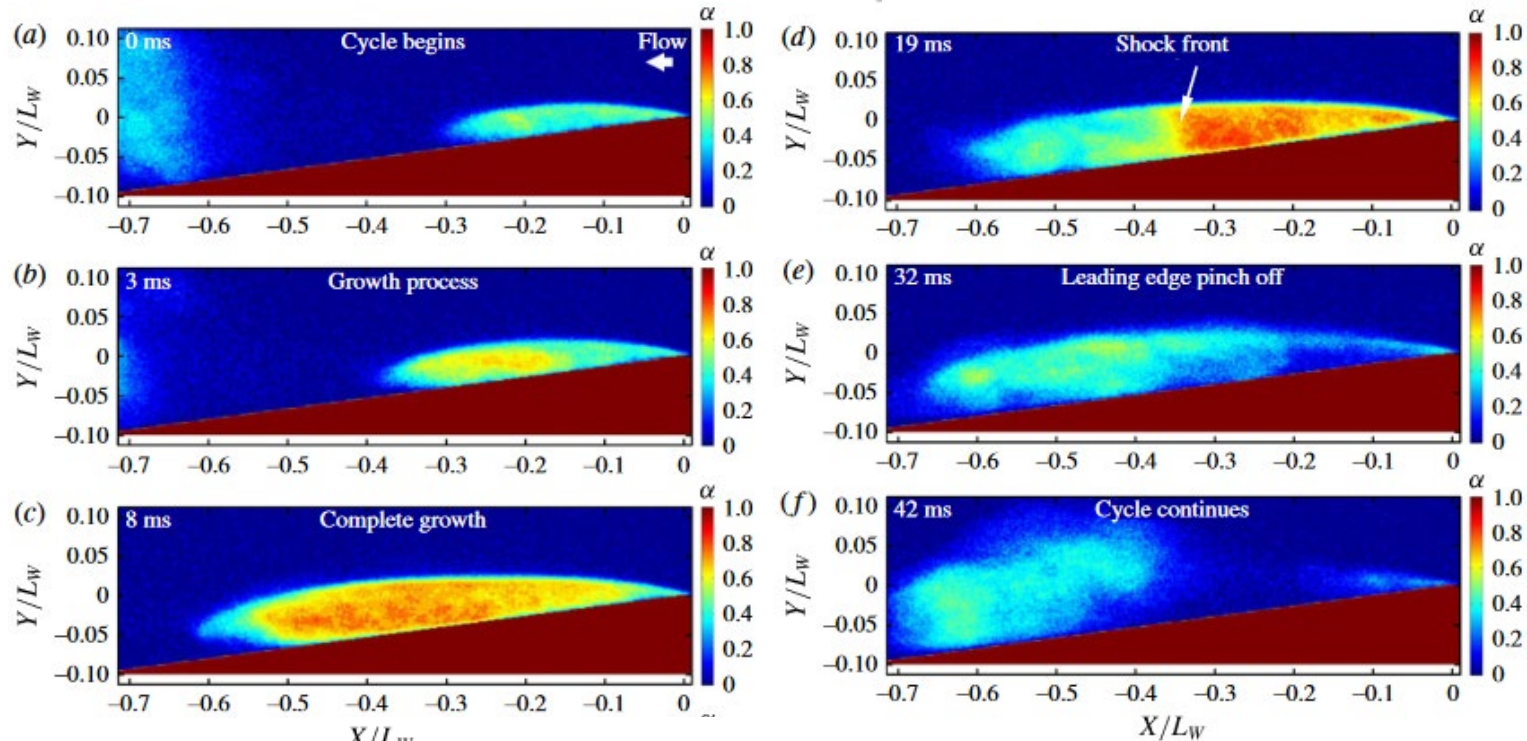

- X-rays reveal void fractions as low as 30% inside the cavity
- In a bubbly mixture, the speed of sound depends on the void fraction and can fall far below the speed of sound in air. It can even fall below the upstream velocity, leading to a supersonic flow in the mixture.

\* H. Ganesh et al., "Bubbly shock propagation as a mechanism for sheet-to-cloud transition of partial cavities », JFM, 2016

# The Leading Edge Cavitation

- Effects on hydrodynamic performances of a Naca 0009 hydrofoil
  - Partial cavitation : Increase of hydrodynamic efficiency
  - Super Cavitation : Sharp decrease of hydrodynamic efficiency (Stall)
  - Transition Partial  $\rightarrow$  Super cavitation : Highly unstable with strong vibration

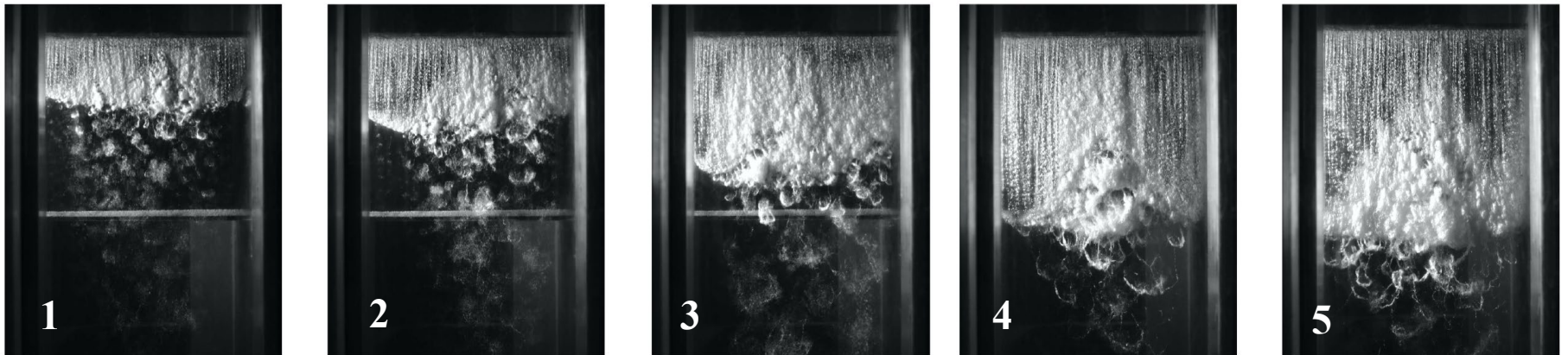
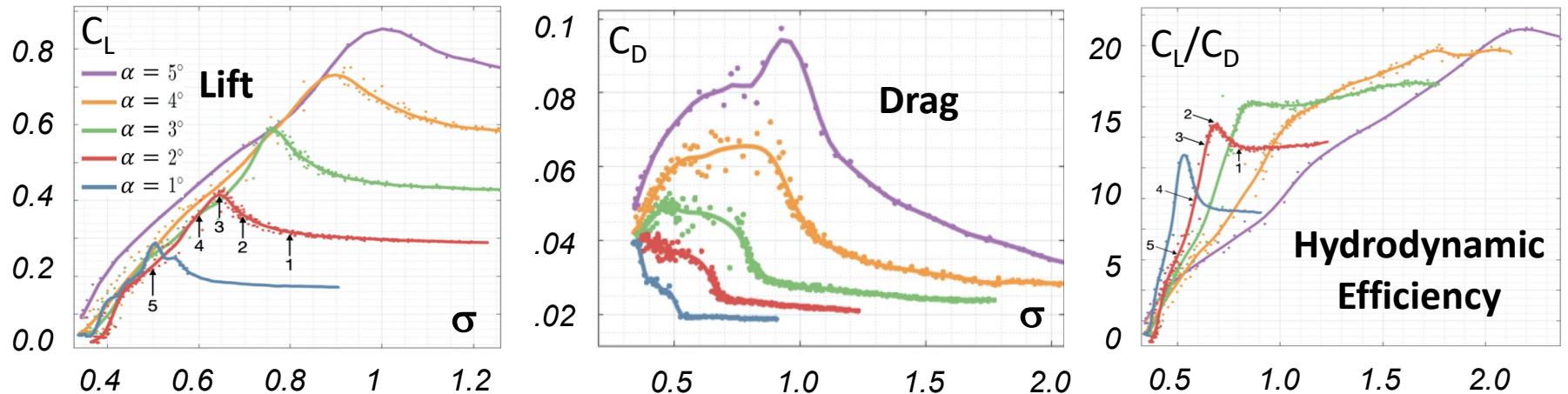

# The Leading Edge Cavitation

- Evidence of luminescence in cavitating flows:
  - Case study: Leading edge cavitation on a NACA009 hydrofoil ( $c = 100 \text{ mm}$ )
    - Incidence:  $\alpha = 3.5^\circ$ , Cavitation Nb.  $\sigma = 0.95$ , Flow velocity:  $C = 20 \text{ to } 35 \text{ m/s}$

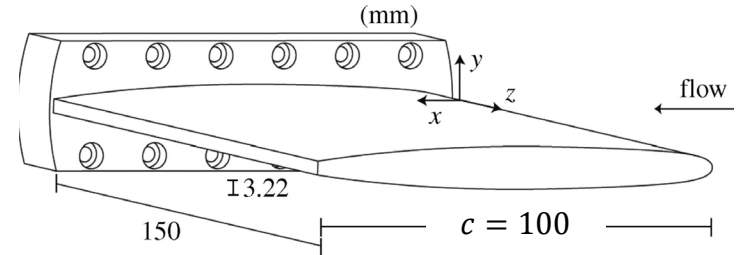

- Instrumentation:
  - Photons counting (photomultiplier)
  - Light-intensified camera
- Tests are performed in a complete dark (night time with all lights off)

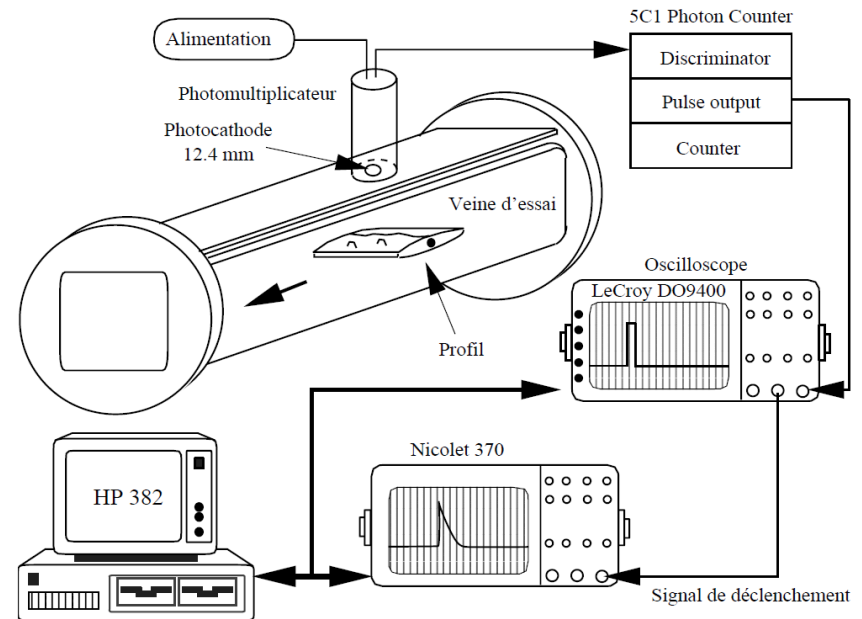
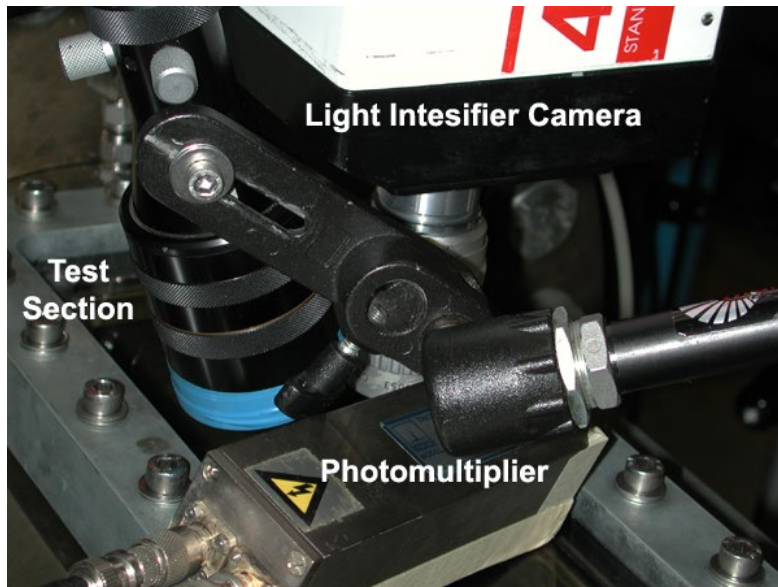

# The Leading Edge Cavitation

- Evidence of luminescence in cavitating flows:

$$\alpha = 3.5^\circ, \sigma = 0.95$$

- Left: Top view of attached cavitation

- Right: Light-intensified images

- Averaged over 50 images  
→ 1 sec exposure time

- Light spots clearly visible downstream of leading edge cavity

- Transition to cloud cavitation  
→ Increase of luminescence

- Luminescence increases with upstream velocity

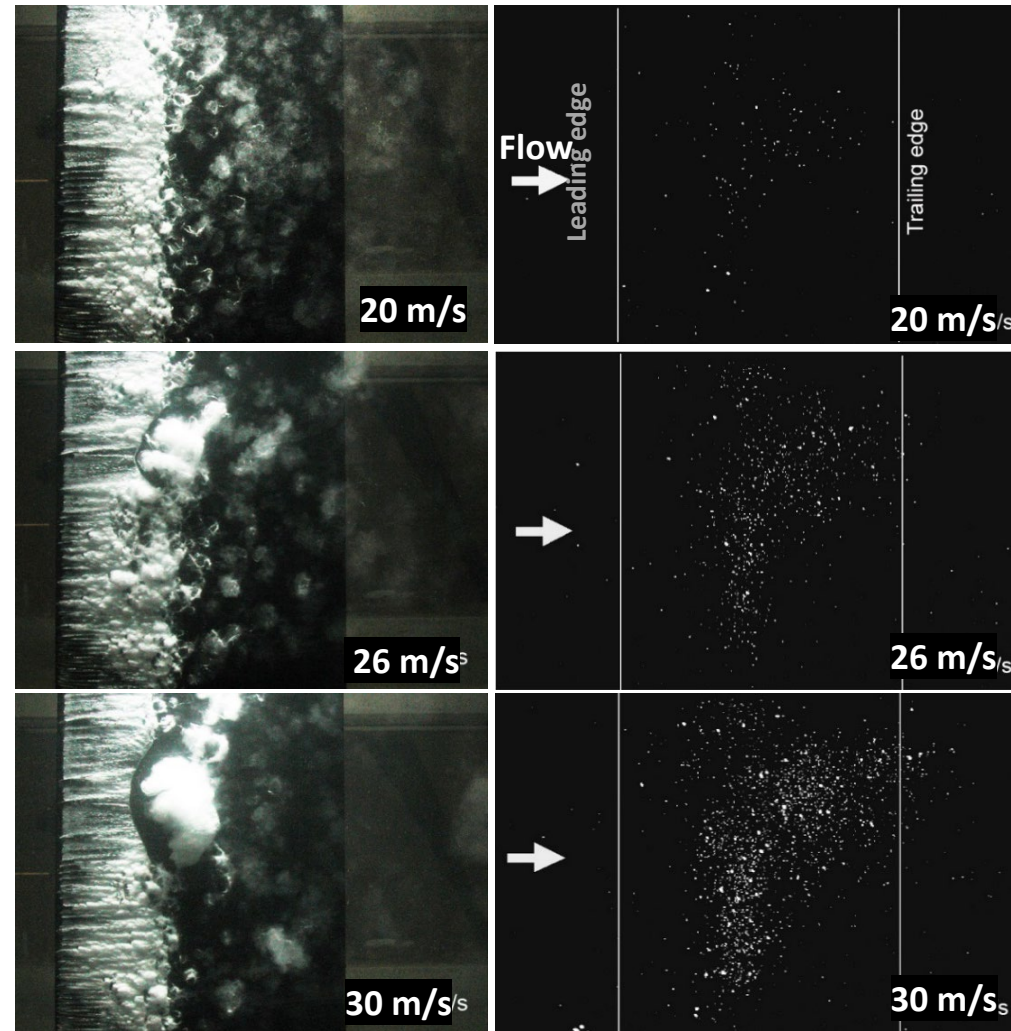

# The Leading Edge Cavitation

- Evidence of luminescence in cavitating flows:
- Photomultiplier signal for different flow velocities
- Evidence of bursting character of photons arrival on the sensor
- Increase of intensity & frequency of the photon bursts with flow velocity
- Frequency ?

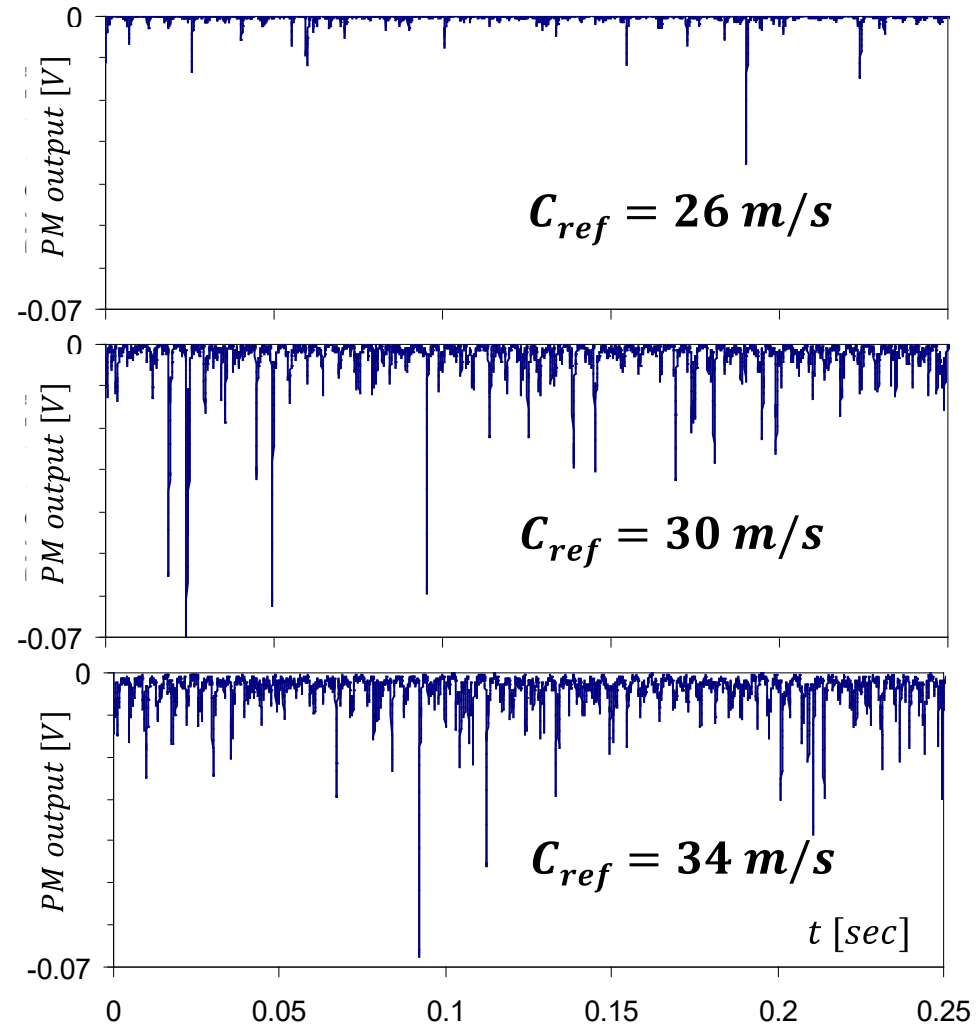

# The Leading Edge Cavitation

- Evidence of luminescence in cavitating flows:
- Spectral analysis of the photons count signals, vs  $f^* = f \cdot c / C_{ref}$ 
  - No peak is visible for  $C_{ref} \leq 20 \text{ m/s}$  (sheet cavitation, random shedding)
  - As the velocity increases beyond  $20 \text{ m/s}$ , the photons bursts become more and more periodic with  $f^* \approx 0.25$ 
    - The bursts frequency matches the Strouhal frequency  $f^* = S_t$
    - The luminescence is modulated by the collapses of transient cavities

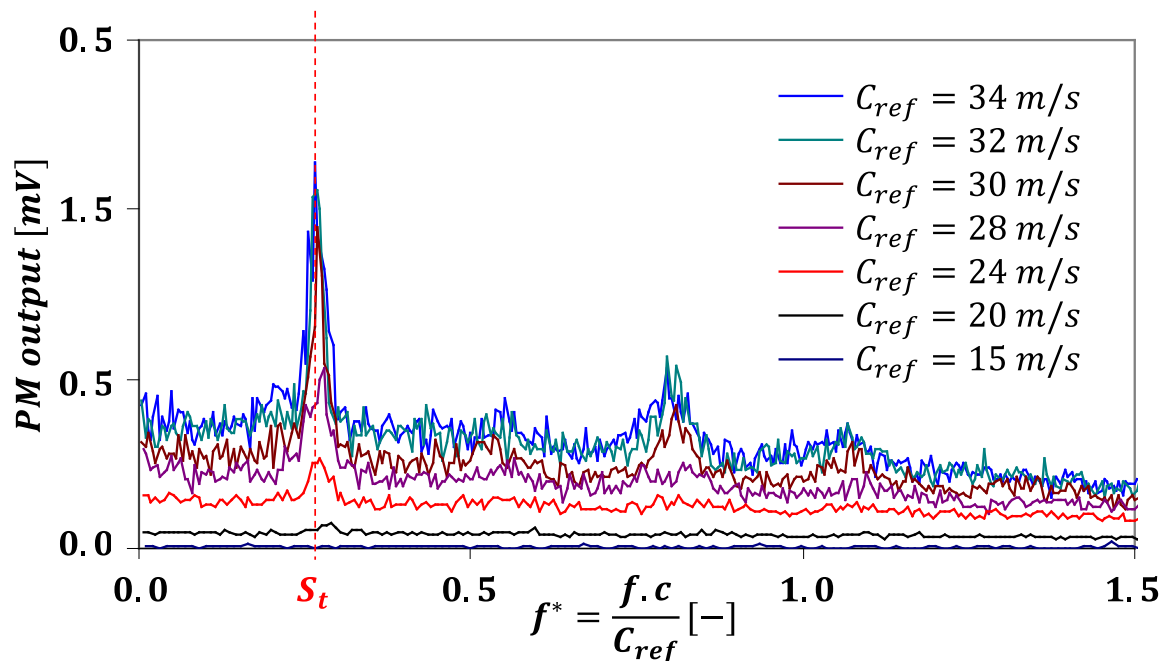

# The Leading Edge Cavitation

- Evidence of luminescence in cavitating flows:

- Rate of photons emission vs flow velocity
- Threshold (Velocity  $\sim 20$  m/s) below which luminescence is not measurable
- Photons count increases with flow velocity

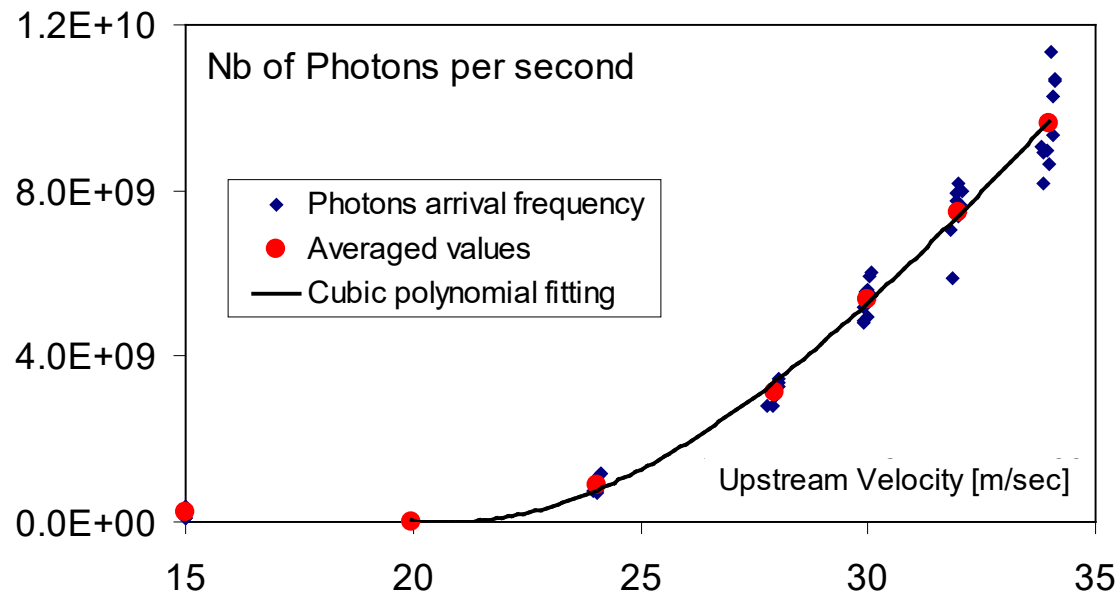

- Luminescence as a method for cavitation detection ?

- Not possible: luminescence is more dependent on the sphericity of the collapse of cavitation bubbles than on their erosive power