

CAVITATION AND INTERFACE PHENOMENA

Chapter 3 : Dynamics of non-spherical cavitation bubbles

3.3 Shockwaves and Luminescence

Part (1/2): Shockwaves

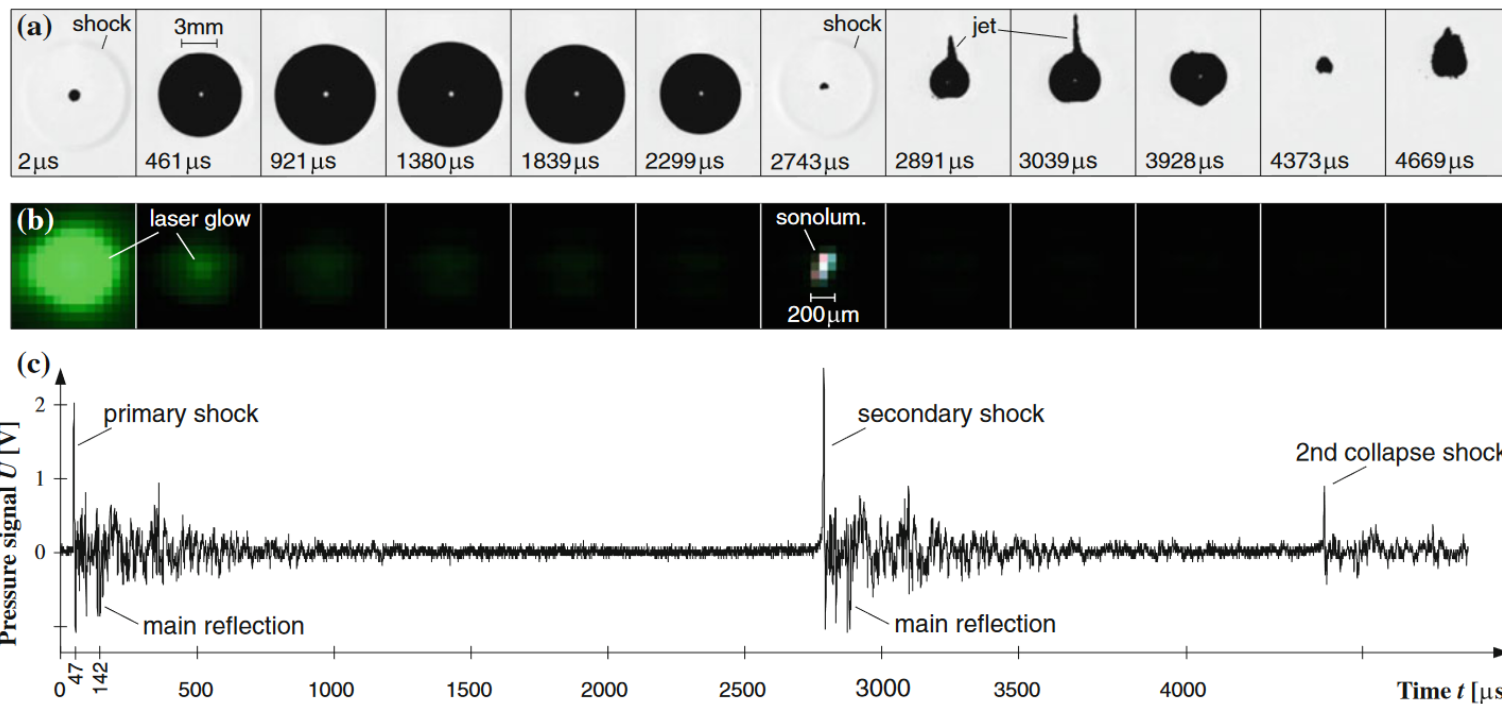

Dr Mohamed FARHAT Assistants: A. Sache, Th. Berger

EPFL – Cavitation Research Group, Avenue de Cour 33 bis, 1007 Lausanne

On the shockwaves induced by a collapsing bubble

- **Experimental methods to investigate shockwaves induced by cavitation:**
 - **Visualization: High speed camera (specific optical setup)**
 - **Shock pressure: Fast sensors**
- **Requirements:**
 - **Pressure front travels at the sound speed and beyond**
 - **The wave front is always thin**
 - **In the case of cavitation induced shockwaves in water:**
 - **Shock over pressure: ~ GPa**
 - **Wave celerity > 1500 m/s**
 - **Thickness of the pressure front < 1 mm**
 - **→ Large frequency band (>> 1 MHz)**

On the shockwaves induced by a collapsing bubble

- Experimental methods to investigate shock waves induced by cavitation:
 - Optical methods - *A way of seeing the invisible*:
 - Principle:
 - Shockwaves are revealed by a parallel illumination, which is deviated by the density (i.e pressure) gradient across the shock front
 - Significant change of density \rightarrow alteration of refraction index

Refraction index vs pressure (water)

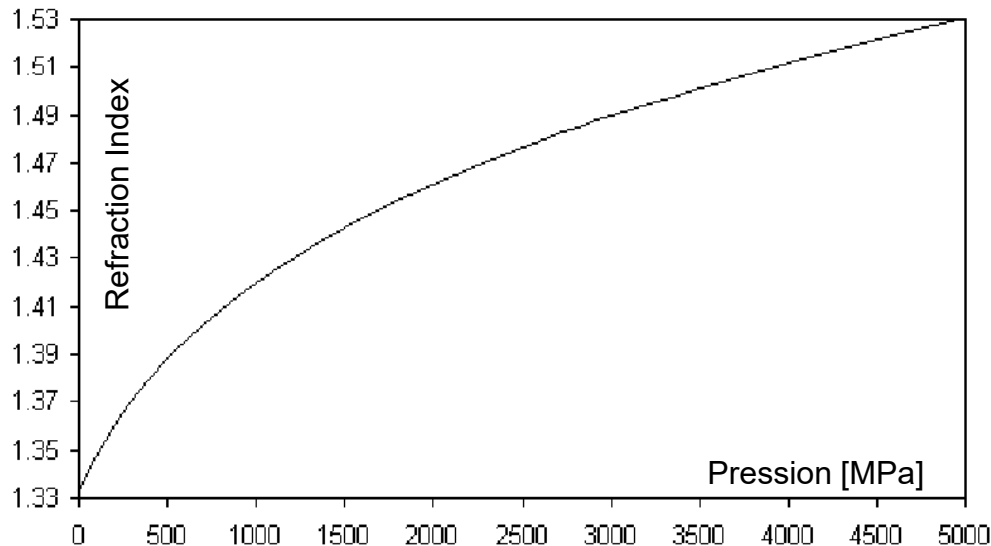

Simulation of light deviation by a shockwave front

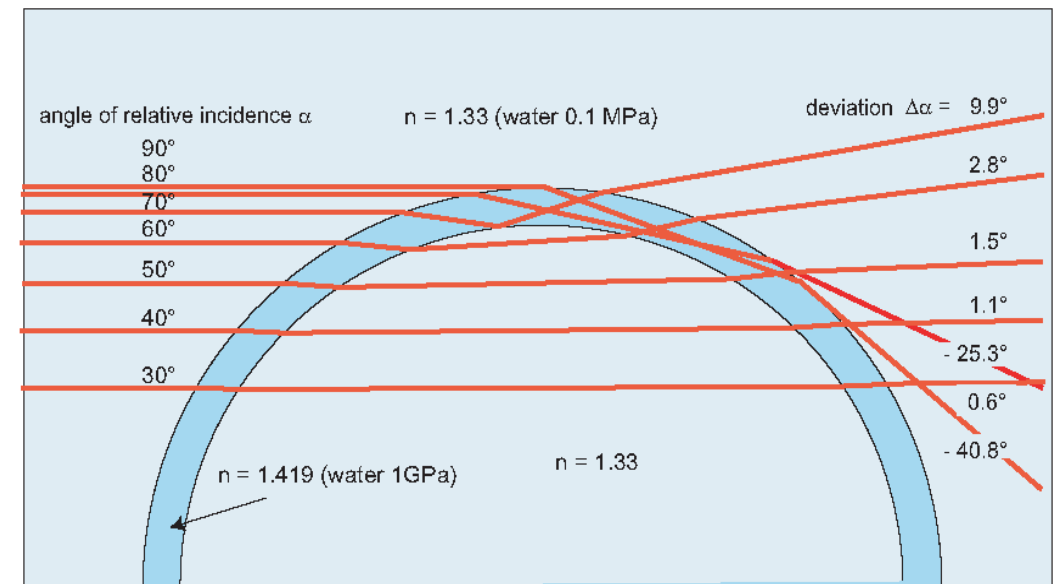

On the shockwaves induced by a collapsing bubble

- Optical methods to visualize density gradients:
 - Shadowgraphy
 - Schlieren (invented in 19th century)
 - More sophisticated technique, which uses a knife edge and convergent lenses
 - Better filtering of deviated beams

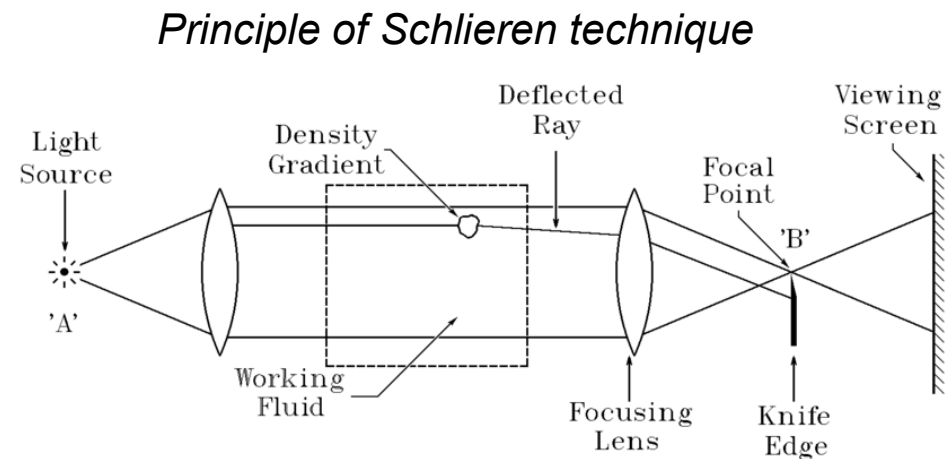
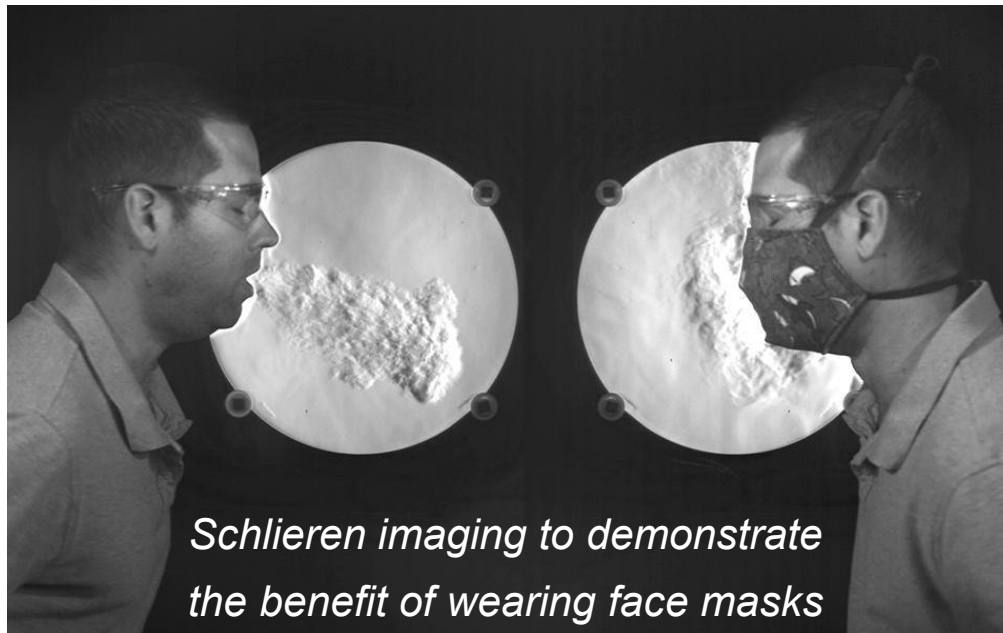
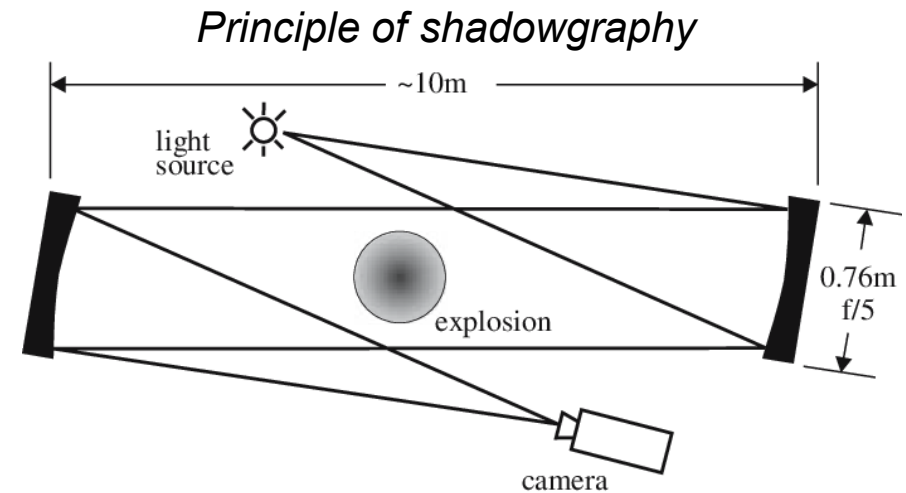

On the shockwaves induced by a collapsing bubble

- **Optical methods to visualize density gradients:**
 - **Background Oriented Schlieren (BOS)**
 - Uses a background image, viewed with and without density gradient.
 - Image processing \rightarrow derive the spatial gradient of the refractive index integrated along the optical path
 - **Example: BOS technique to reveal supersonic shockwaves generated by a NASA F-18, viewed from a 2nd plane flying above the subject and using natural desert vegetation as the speckled background pattern**

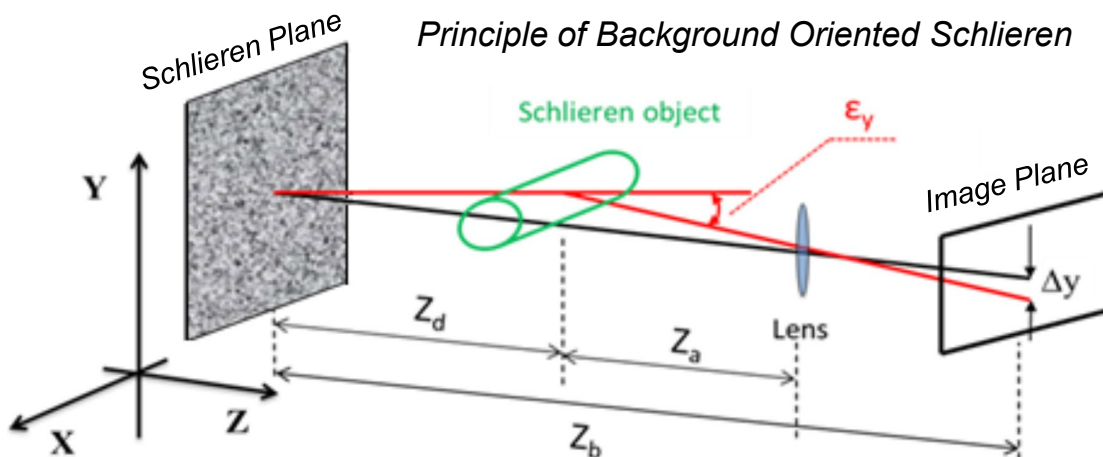

On the shockwaves induced by a collapsing bubble

- Experimental methods to investigate shock waves induced by cavitation:

- Pressure sensing:

- Conventional piezoelectric pressure sensors:

- Frequency band ~ 10 to 100 KHz

- Sensing area: 1 to 10 mm

- Conventional sensors inappropriate

- Needle hydrophones (miniature piezoelectric sensors)

- Needle diameter ~ 10-100 μm

- Frequency range: ~50 MHz

- Suitable for shockwave measurement

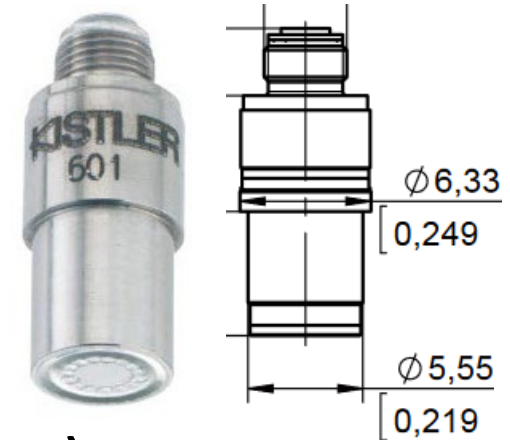

On the shockwaves induced by a collapsing bubble

- **Transient pressure measured by needle hydrophones**
 - **Case study: Laser induced bubble in variable pressure gradients**
 - **Experimental Setup**

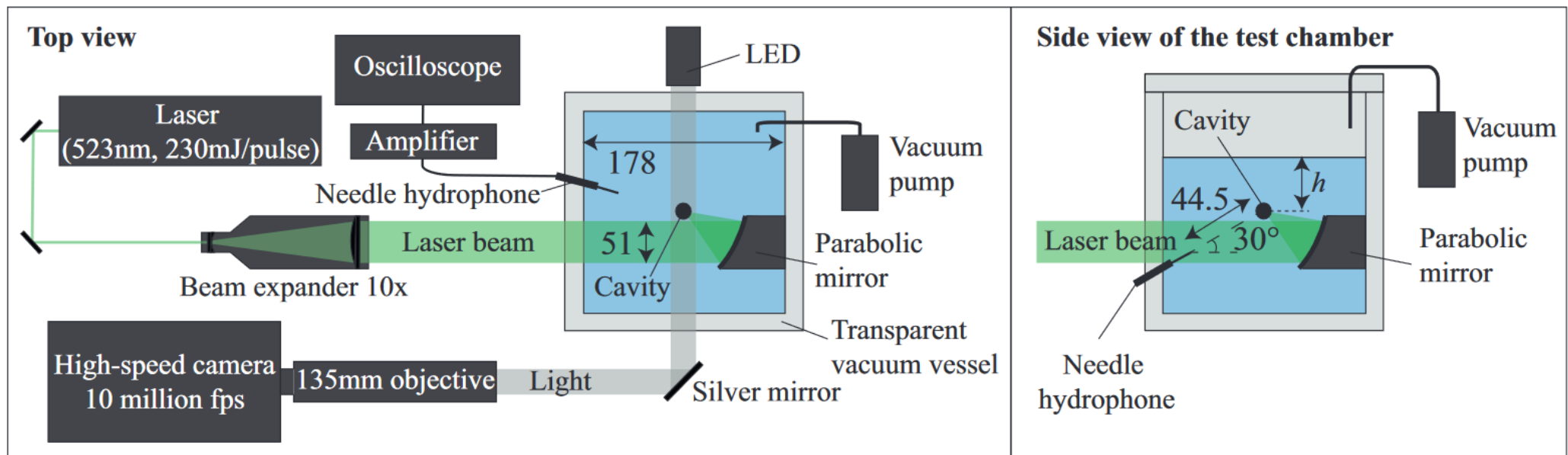

On the shockwaves induced by a collapsing bubble

- Transient pressure measured by needle hydrophones
 - Case study: Laser induced bubble in variable pressure gradient
- Typical hydrophone signal of the shockwave emitted at the bubble generation
 - $t = 0 \mu\text{s}$: bubble generation
 - $t \sim 29.8 \mu\text{s}$: the shockwave reaches the hydrophone, located 44.5 mm away from the bubble center ($0.0445/0.0000298 = 1490 \text{ m/s}$)

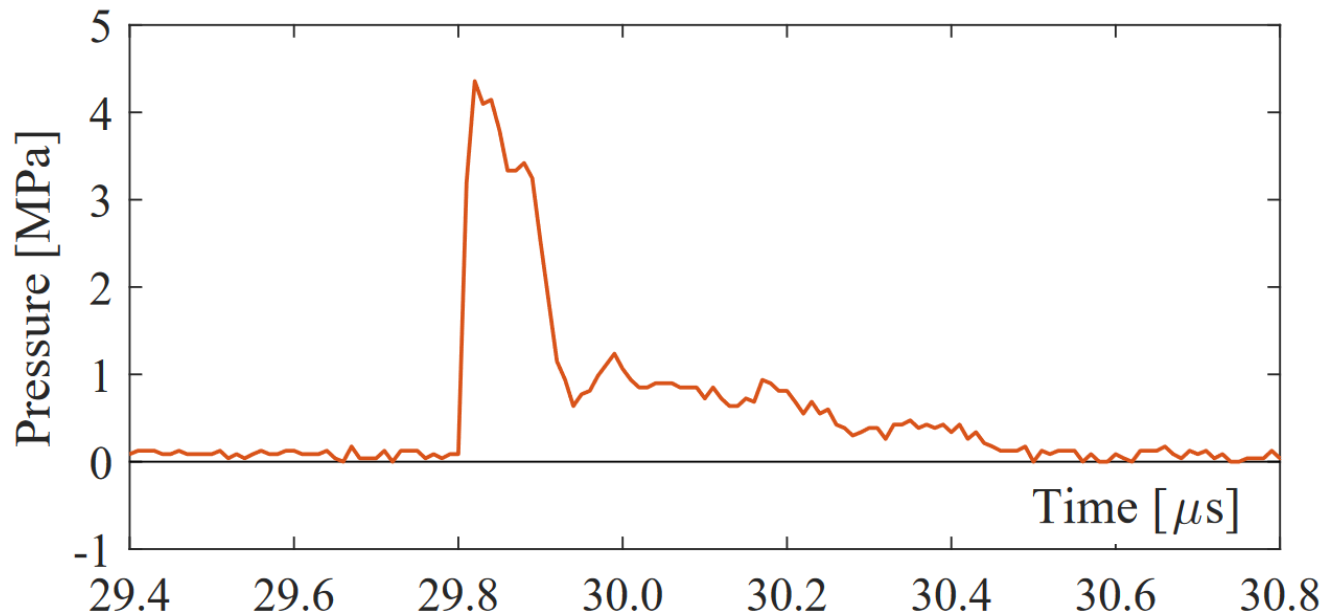

On the shockwaves induced by a collapsing bubble

- Transient pressure measured by needle hydrophones
 - Case study: Laser induced bubble in variable gravity

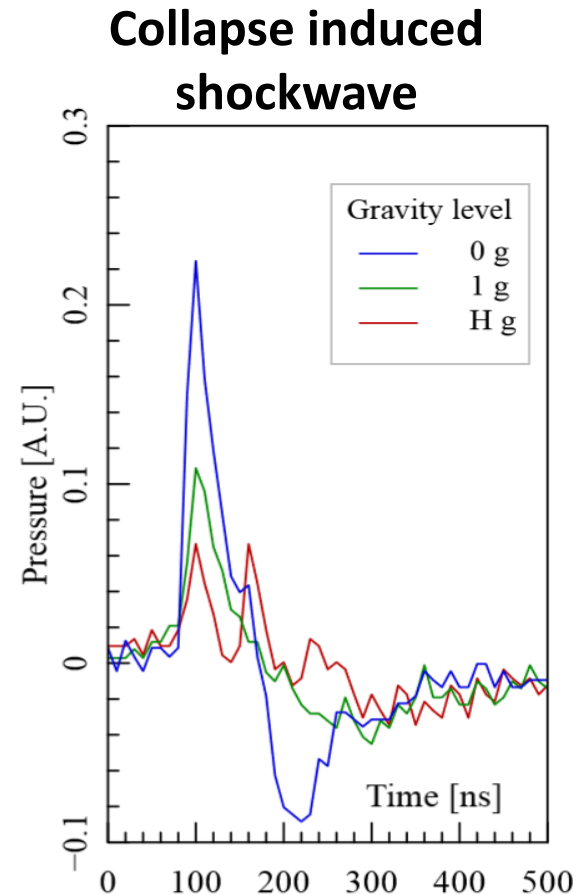
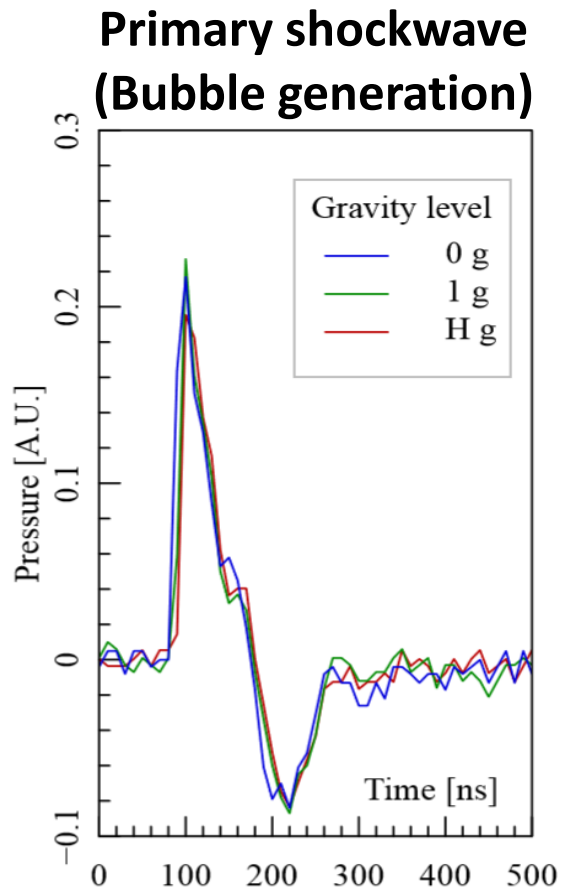

On the shockwaves induced by a collapsing bubble

- Effect of bubble deformation on the collapse induced shockwaves energy

Bubble energy: $E_0 = \frac{4\pi}{3} R_0^3 \Delta p$

Shockwave energy (E_S):
(spherical propagation)

$$E_S = \frac{4\pi d^2}{\rho c} \int p(t)^2 dt$$

$$E_S = a U_{\max}^b \int U(t)^2 dt$$

U : hydrophone voltage, d : distance from the bubble center, a and b : calibration constants

- Calibration (find a and b such as the following conditions are satisfied) :

- $E_{S,gen}$ scales linearly with E_0
- $E_{S,coll}$ is bounded by $E_0 - E_{Rebound}$

For $\zeta < 10^{-3}$ (spherical collapse), we assume $E_{S,coll} \approx E_0 - E_{Rebound}$

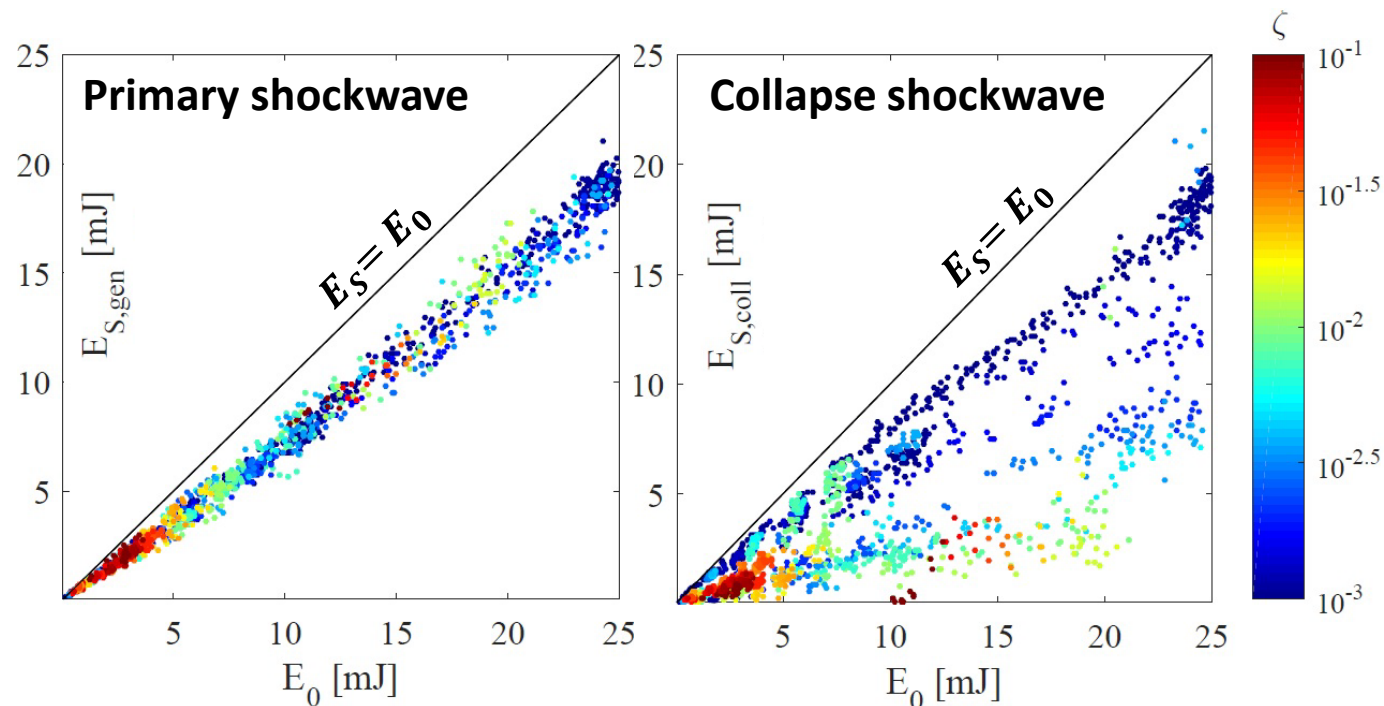

On the shockwaves induced by a collapsing bubble

- Shadowgraph visualization of the last stage of bubble collapse
 - Highly spherical bubble ($\xi < 0.001$)
 - $R_{max} = 3.8 \text{ mm}$
 - 10 million frames/second
 - Single spherical shockwave

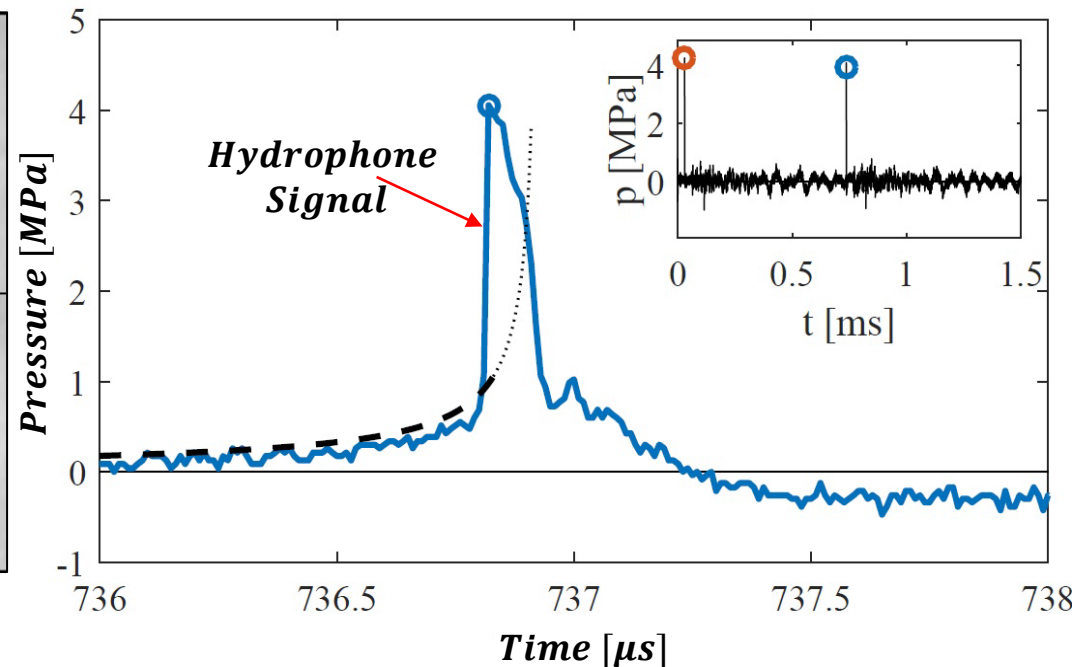
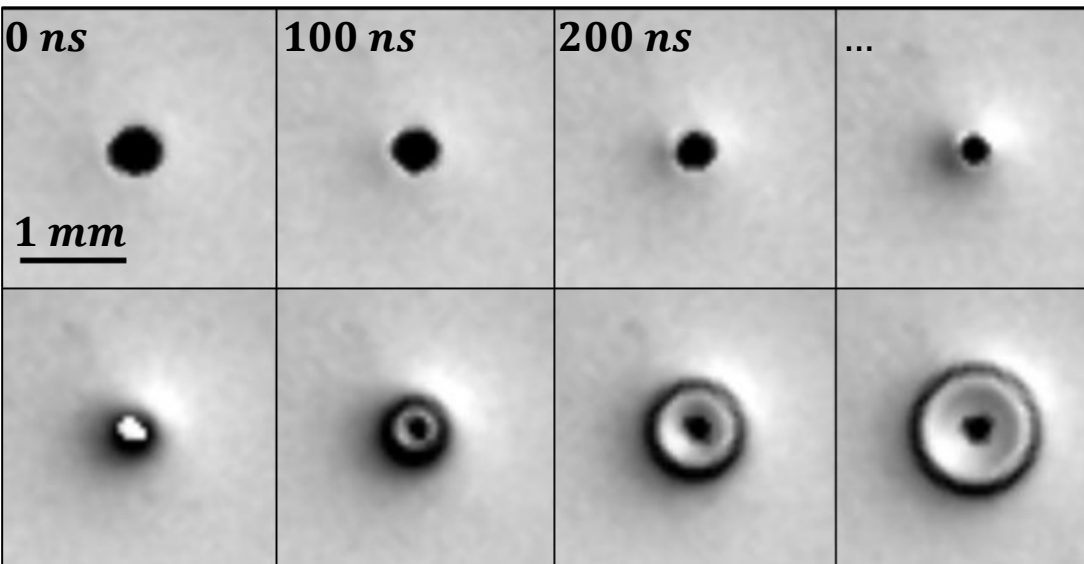
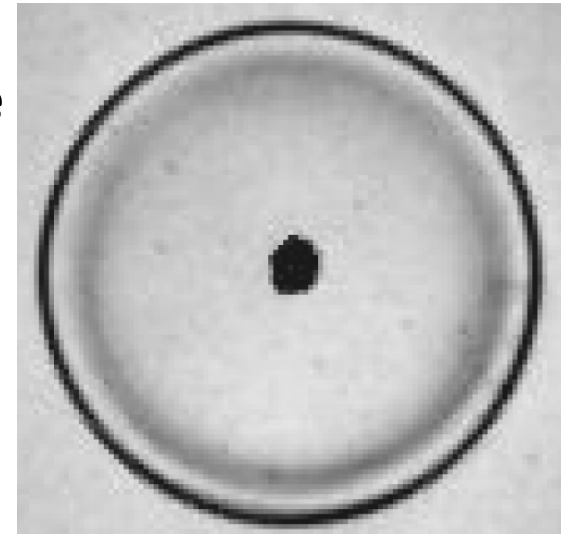

On the shockwaves induced by a collapsing bubble

- Bubble deformation, in the case of a neighboring free surface
 - Shape of a bubble collapsing near a free surface
 - Potential flow computation (Boundary Integral Method)

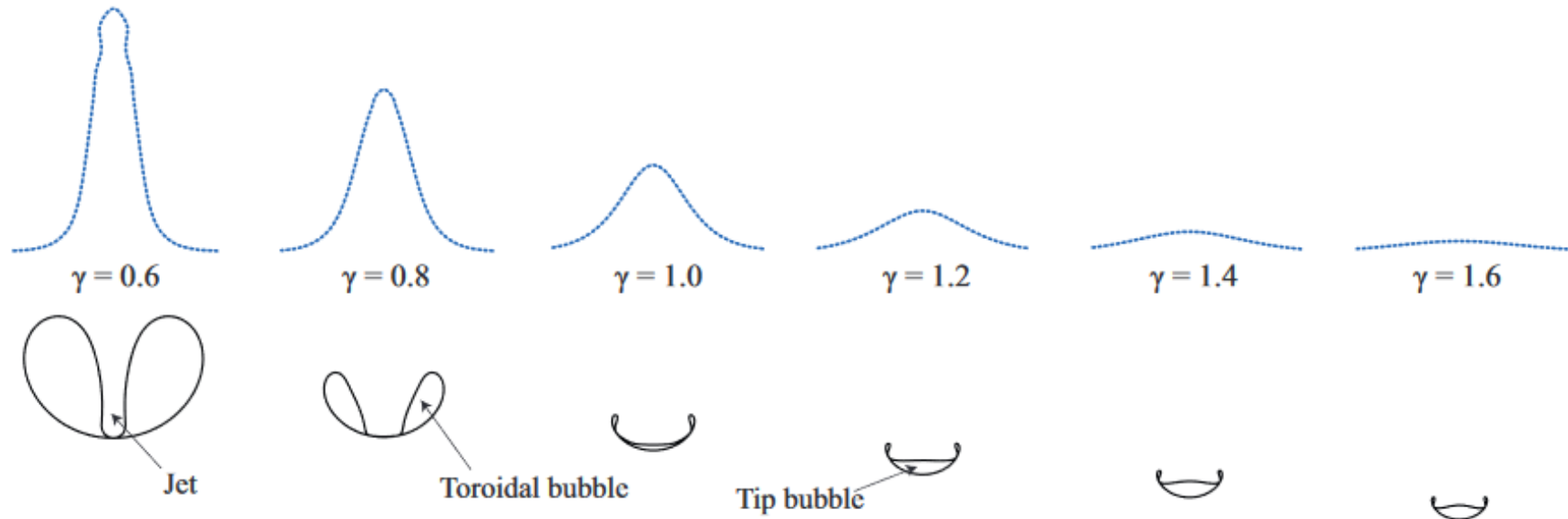

- Source of shockwave emission:
 - Jet impact
 - Toroidal bubble collapse
 - Tip bubble collapse

On the shockwaves induced by a collapsing bubble

- Shock waves from a bubble collapsing near a free surface:
- Shock waves from a bubble collapsing near a free surface:
 - Weakly deformed bubble $\xi = 0.0038$ ($\gamma = 7.2$)
 - $R_{max} = 3.8 \text{ mm}$
 - 10 million frames/second

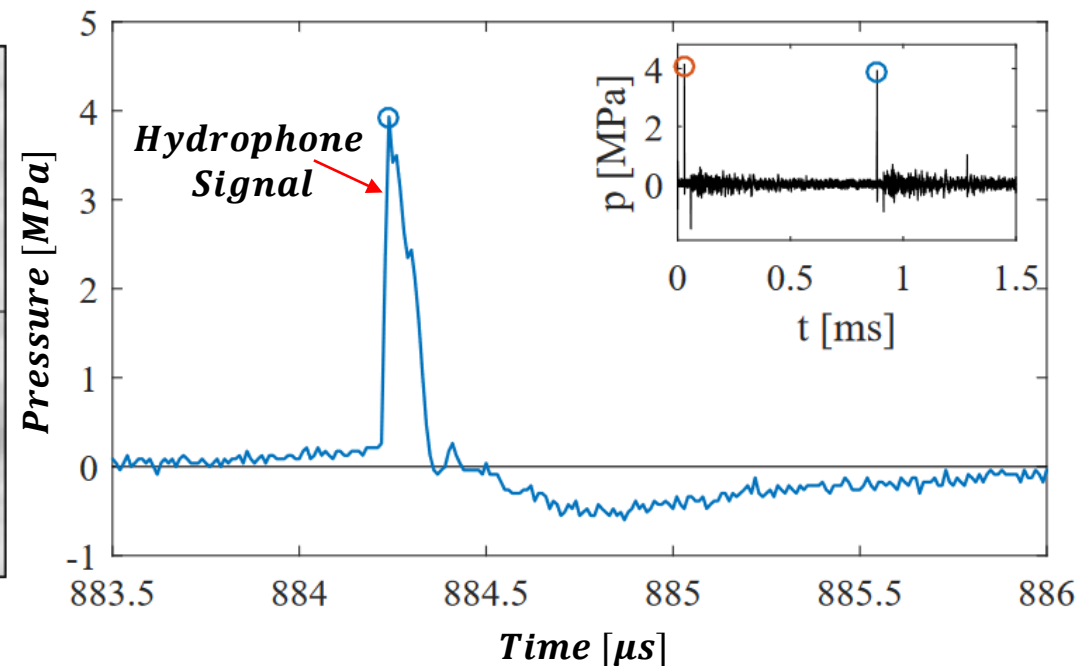
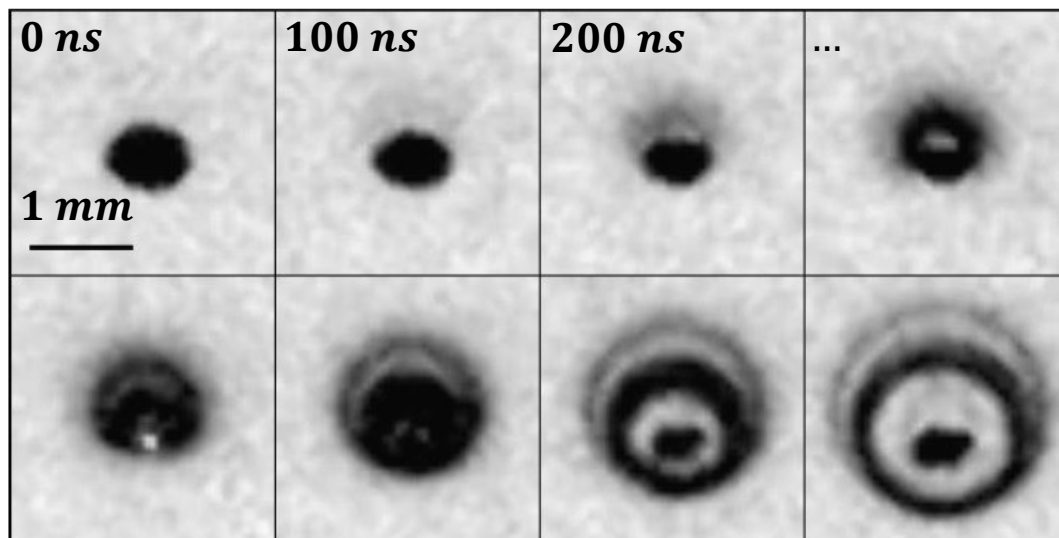

On the shockwaves induced by a collapsing bubble

- Shock waves from a bubble collapsing near a free surface:
 - More deformed bubble (increasing ζ)

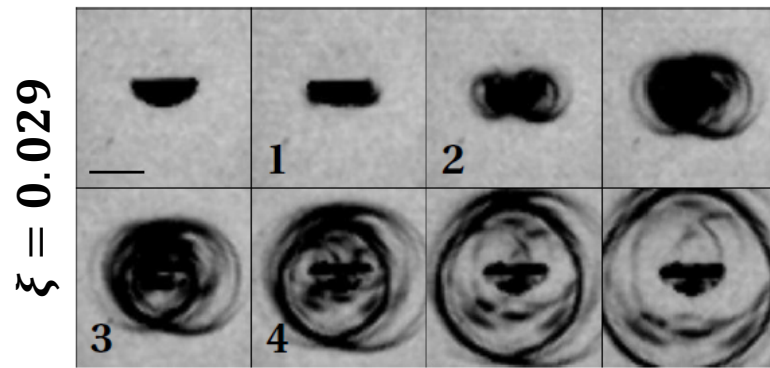

(a) The interframe time is 200 ns.

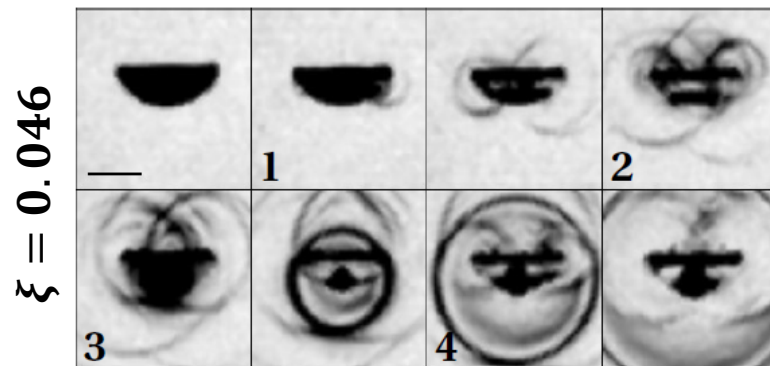

(c) The interframe time is 300 ns.

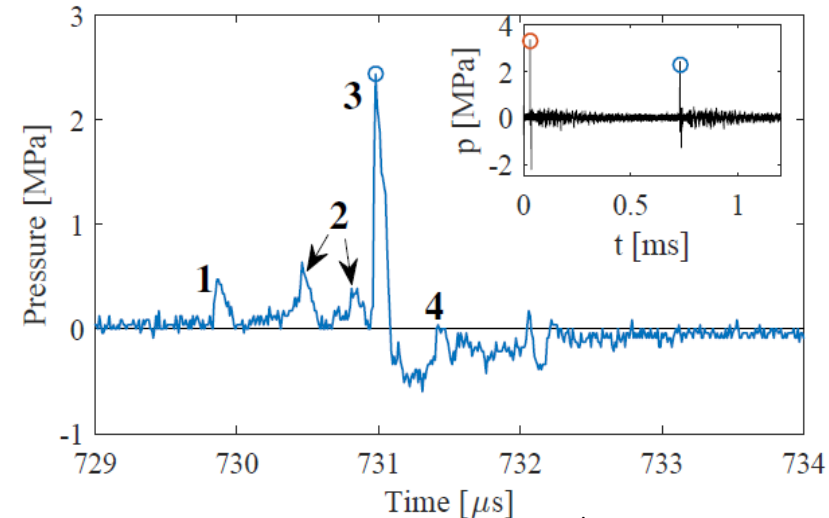
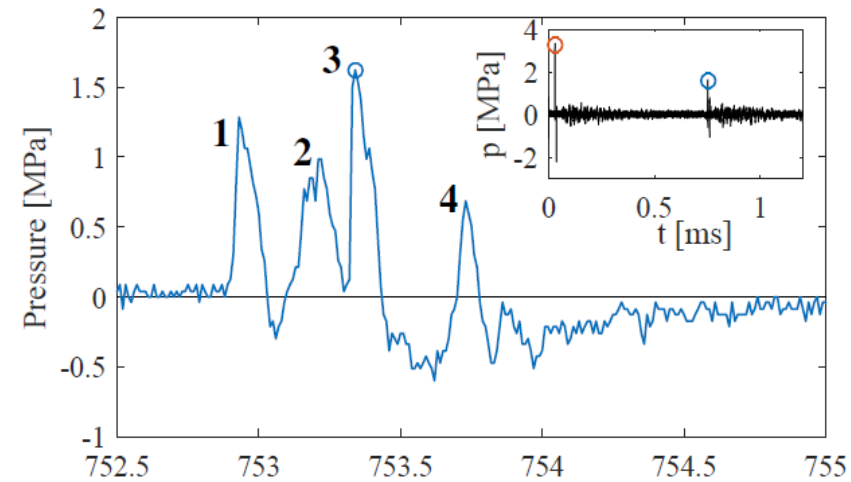

1) jet impact, 2) torus collapse, 3) tip bubble collapse, 4) second torus collapse, 5) 2nd tip bubble collapse

On the shockwaves induced by a collapsing bubble

- Shock waves from a bubble collapsing near a free surface:
 - More deformed bubble (increasing ζ)

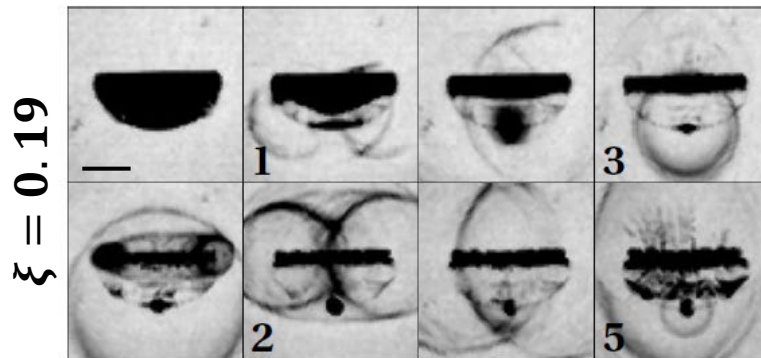

(e) The interframe time is 600 ns.

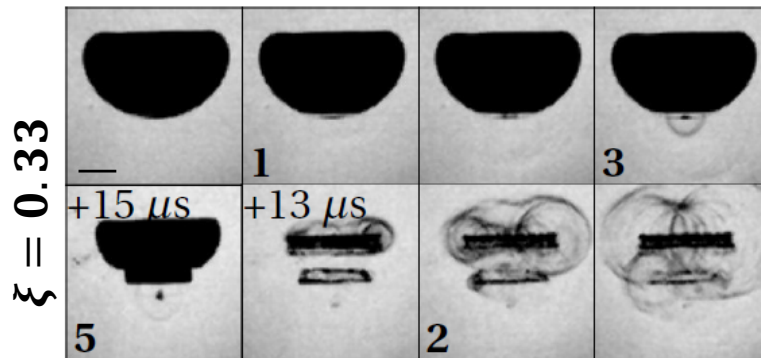

(g) The interframe time is 400 ns unless otherwise indicated.

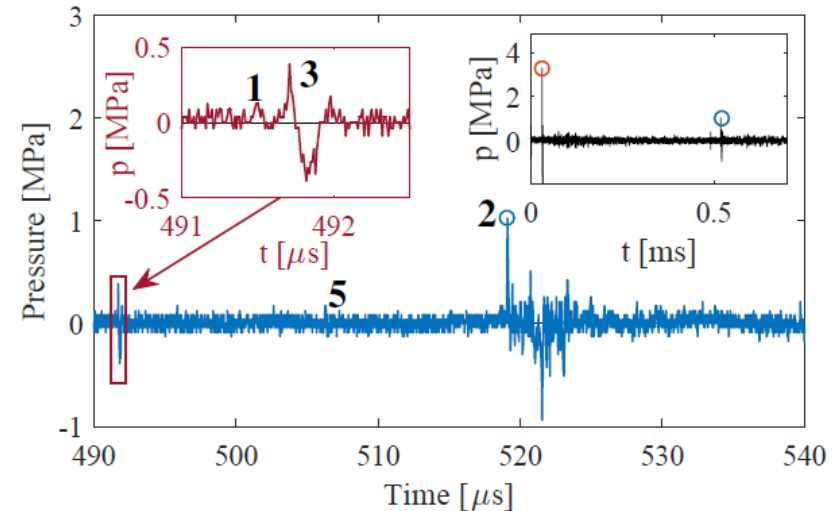
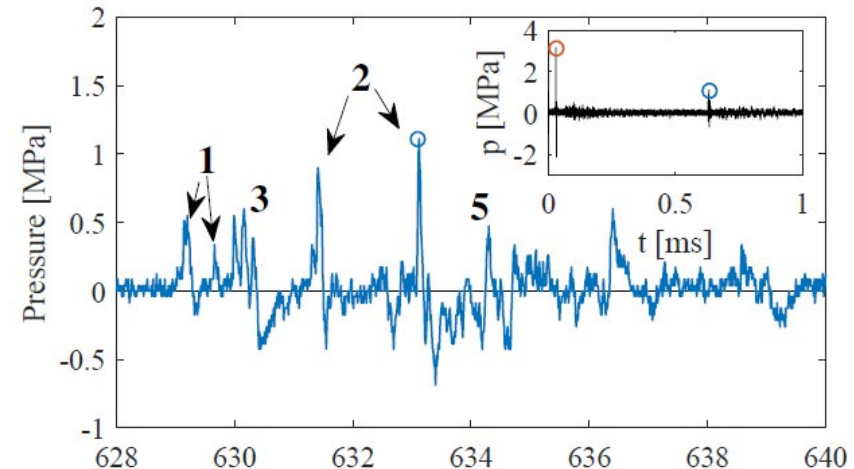

1) jet impact, 2) torus collapse, 3) tip bubble collapse, 4) second torus collapse, 5) 2nd tip bubble collapse

On the shockwaves induced by a collapsing bubble

- Comparison of bubbles deformed by gravity, free and rigid surfaces
 - Similar trend: shockwave energy increases with decreasing ζ
 - Slight dependence on the source of deformation
 - Shockwave energy higher with free surface than gravity at a given ζ

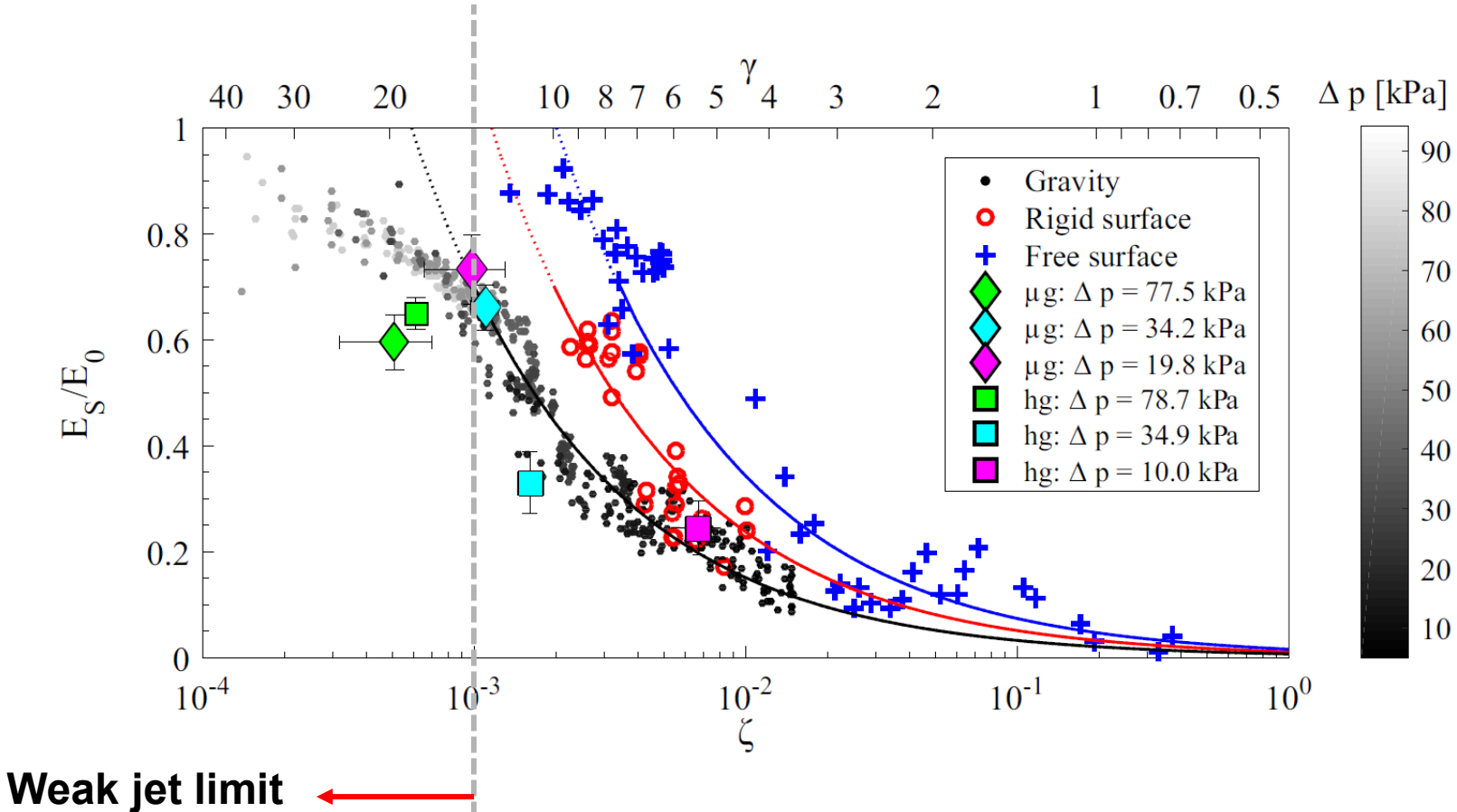

On the shockwaves induced by a collapsing bubble

- Evidence of pressure build-up during the collapse of a cavitation bubble

We have seen in Chapter 2.2 that owing to Rayleigh model, $\frac{p - p_\infty}{p_\infty - p_v}$, the pressure everywhere in the liquid is given by:

$$\frac{p(r) - p_\infty}{p_\infty - p_v} = \frac{R}{3r} \left(\frac{R_0^3}{R^3} - 4 \right) - \frac{R^4}{3r^4} \left(\frac{R_0^3}{R^3} - 1 \right)$$

Max $(p(r)) = p_{max}$ for $r=r_{max}$:

$$r_{max} = R \left[\frac{1 - \frac{R^3}{R_0^3}}{1 - 4 \frac{R^3}{R_0^3}} \right]^{\frac{1}{3}} \quad \frac{p_{max} - p_\infty}{p_\infty - p_v} = \frac{1}{4^{4/3}} \frac{\left[1 - 4 \frac{R^3}{R_0^3} \right]^{4/3}}{\frac{R^3}{R_0^3} \left[1 - \frac{R^3}{R_0^3} \right]^{1/3}}$$

$$\lim_{R \rightarrow 0} p_{max} = +\infty !!$$

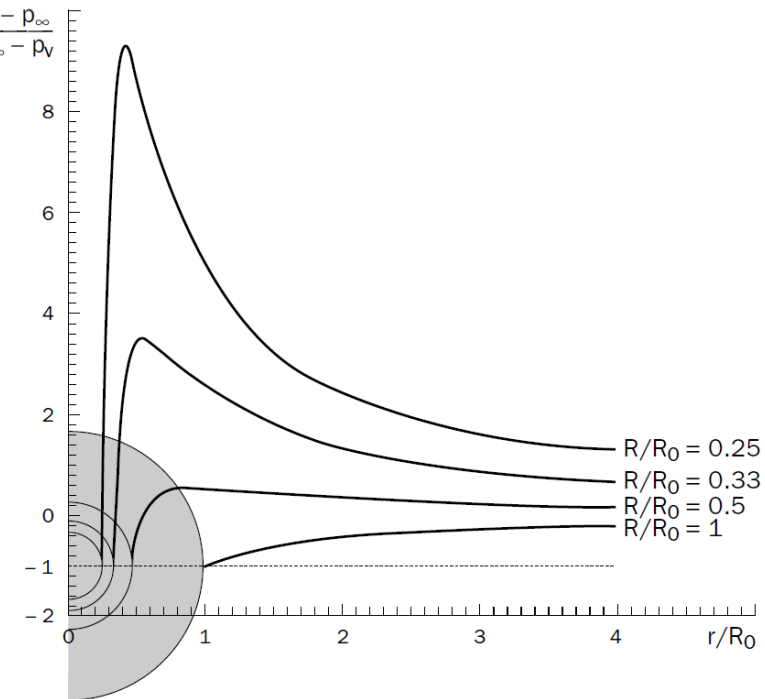

Experimental validation: The pressure increase is hardly measurable because of (i) the fast character of the collapse and (ii) the lack on non-intrusive instrumentation

On the shockwaves induced by a collapsing bubble

- Evidence of pressure build-up during the collapse of a cavitation bubble
 - High speed visualization (10 million frames/second), using shadowgraph technique

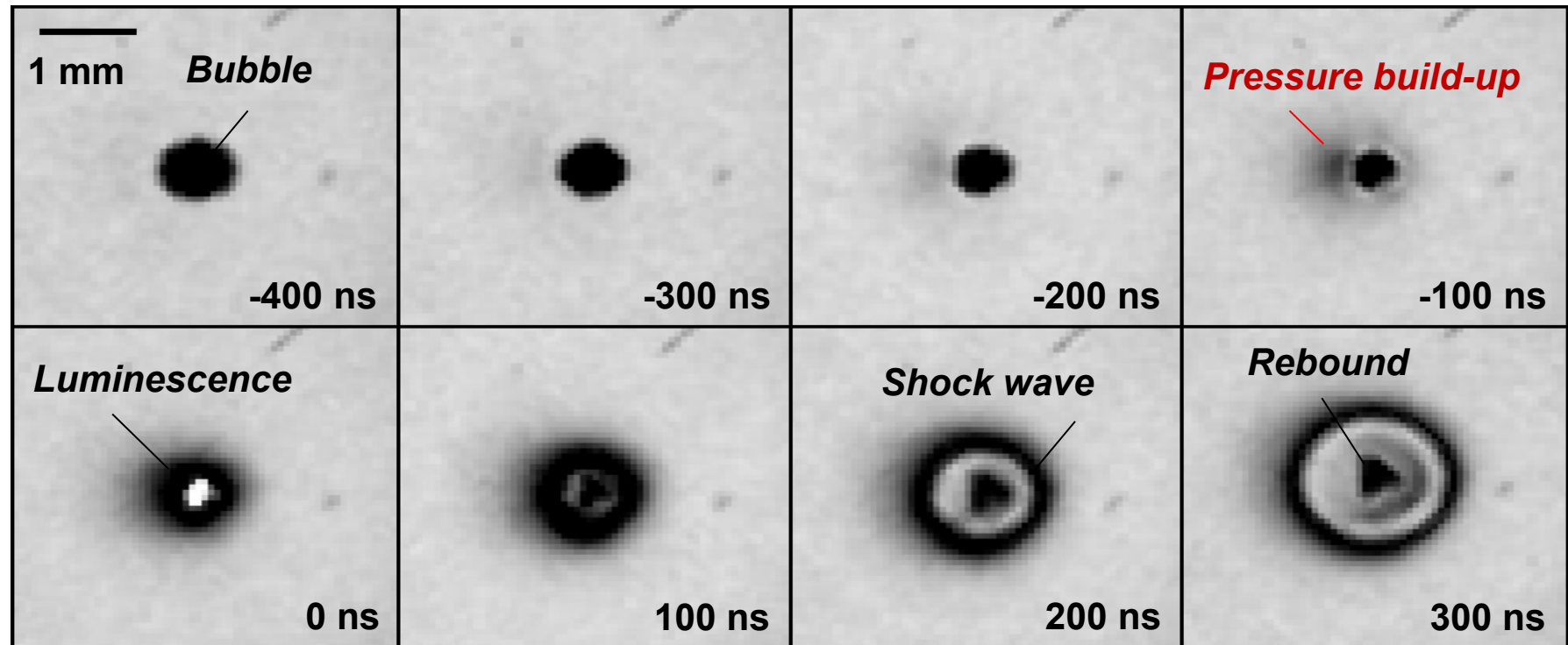

- Dark area is revealed around the bubble, well visible at the final stage of the collapse
 - This light deviation is an indication of a strong density gradient
 - Clear evidence of pressure build-up
- At the same time, pressure is also building up within the non condensable gas

On the shockwaves induced by a collapsing bubble

- Evidence of pressure build-up during the collapse of a cavitation bubble
 - Image processing (Light intensity) → Estimation of pressure increase
 - Qualitative data, in line with Rayleigh prediction
 - Pressure field and location of maximum pressure

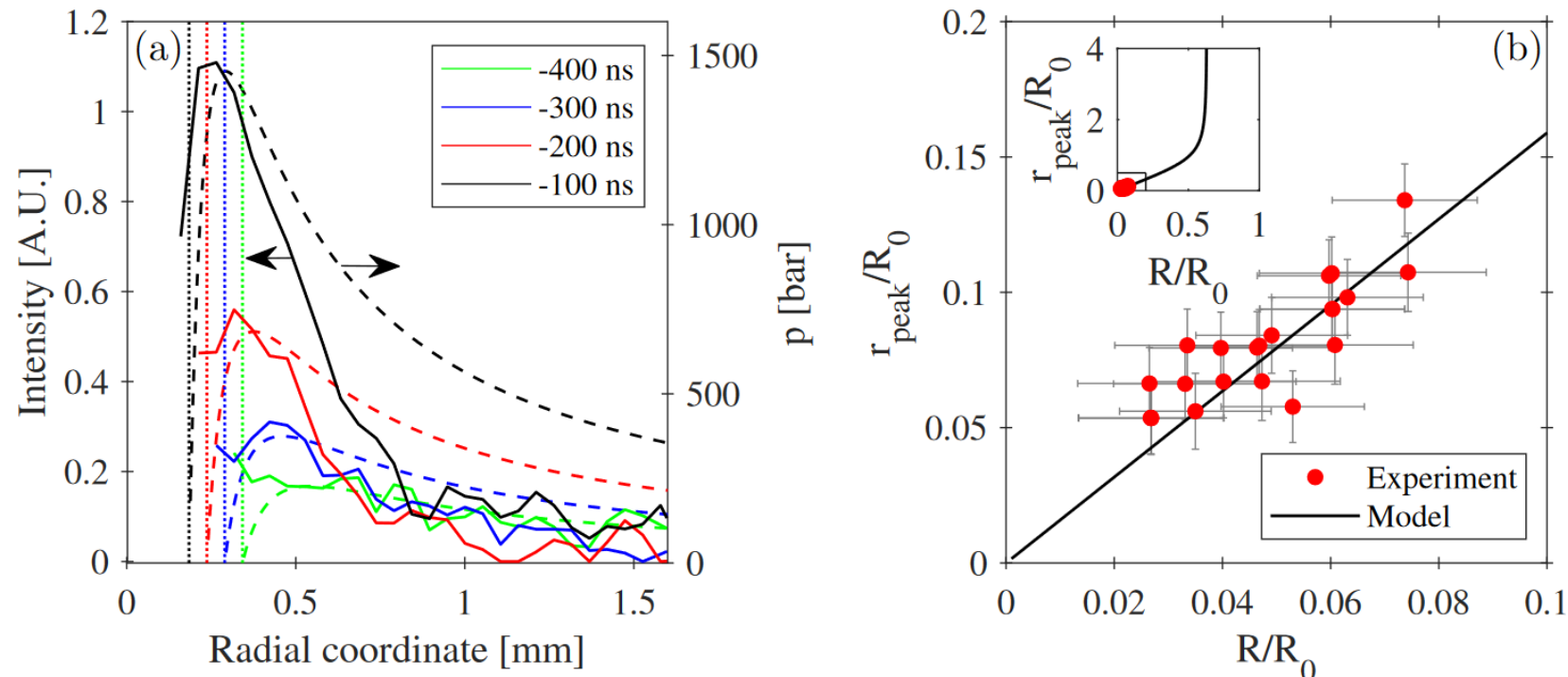

Figure 4. (a) Pressure buildup observed in the experiment as inverse image pixel intensities (left axis, solid lines) and predicted by the model in Eq. (1) (right axis, dashed lines). The bubble radii at the corresponding time instants are shown in dotted lines. (b) The peak pressure location r_{peak}/R_0 obtained from images (aligned shadowgraph illumination) and model as a function of the bubble radius R/R_0 .

On the shockwaves induced by a collapsing bubble

- **Evidence of pressure build-up during the collapse of a cavitation bubble**
 - High speed visualization, using Background Oriented Schlieren (BOS)
 - Image distortion due to the change in the pressure induced gradient of refractive index

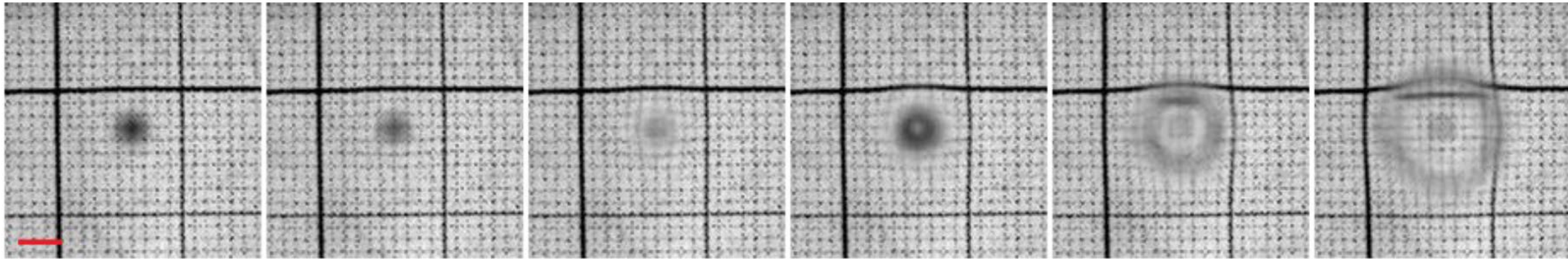

Figure 5. Example of pressure-induced distortion of a reference grid due to the high pressure near the bubble wall in its last collapse stage (frame 3) and the shock wave formed during the rebound stage (frames 4–6). The red bar shows the 1-mm scale and the interframe time is 500 ns.

Cavitation induced shockwaves in real life

- **Case of high-speed cavitating jet (used to test material resistance to cavitation)**
 - High speed immersed water jet impinging on a solid surface (sample)
 - Upstream Pressure : 300 bar
 - Nozzle diameter: ~ 0.5 mm \rightarrow Jet speed: ~ 200 m/s
 - Downstream pressure is varied to adjust cavitation aggressiveness



*Stainless steel sample
after 1 hour exposure*

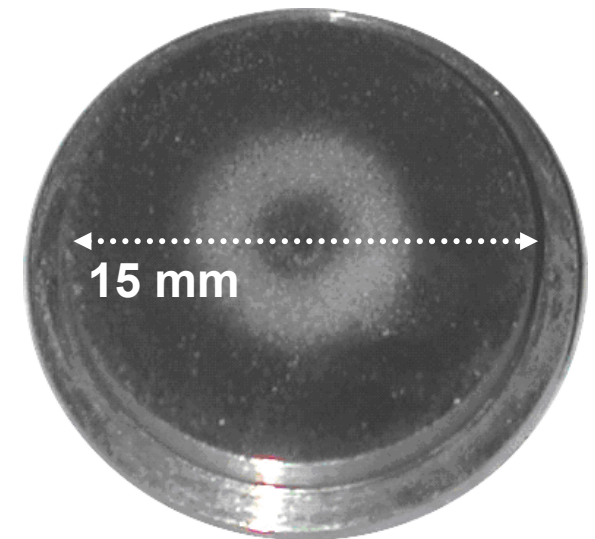

Cavitation induced shockwaves in real life

- **Case of high-speed cavitating jet (used to test material resistance to cavitation)**
 - Unstable shear layer at the jet boundary → formation of toroidal vortices
 - Discrete clouds of bubbles, impinging on the sample → shockwaves

Shadowgraph visualisation of radiated shockwaves by a high speed cavitating jet
(500'000 frames/second, 50 ns exposure time)

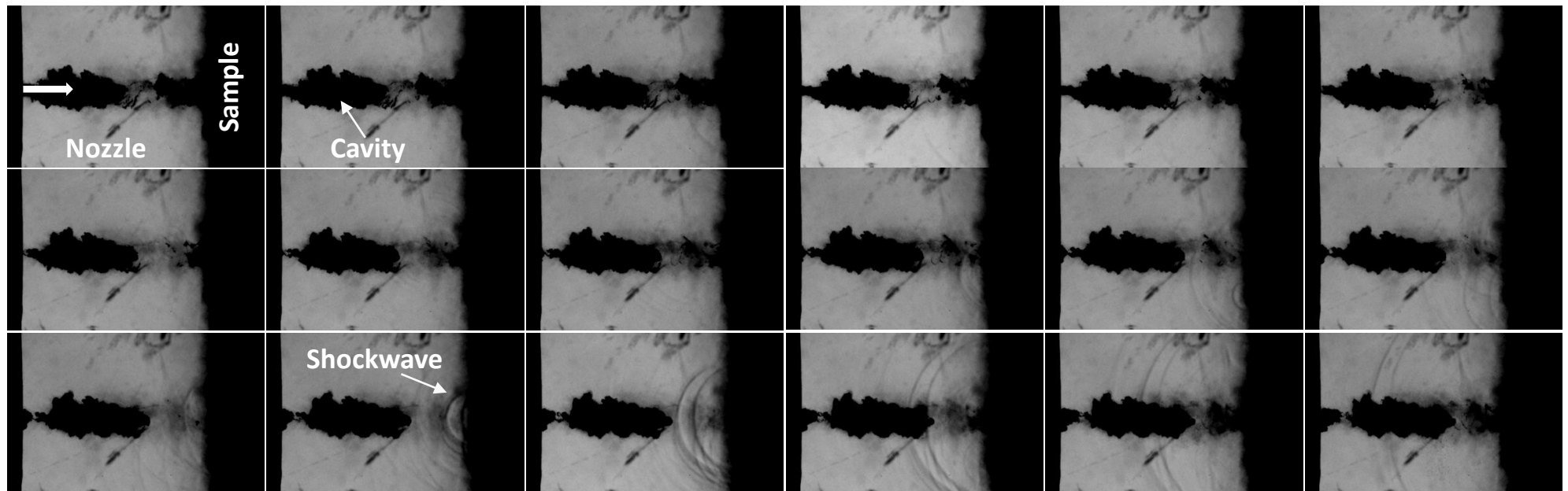

To be continued ...

CAVITATION AND INTERFACE PHENOMENA
Chapter 3 : Dynamics of non-spherical cavitation bubbles
3.3 Shockwaves and Luminescence

Part (2/2): Luminescence

Dr Mohamed FARHAT Assistants: A. Sache, Th. Berger
EPFL – Cavitation Research Group, Avenue de Cour 33 bis, 1007 Lausanne

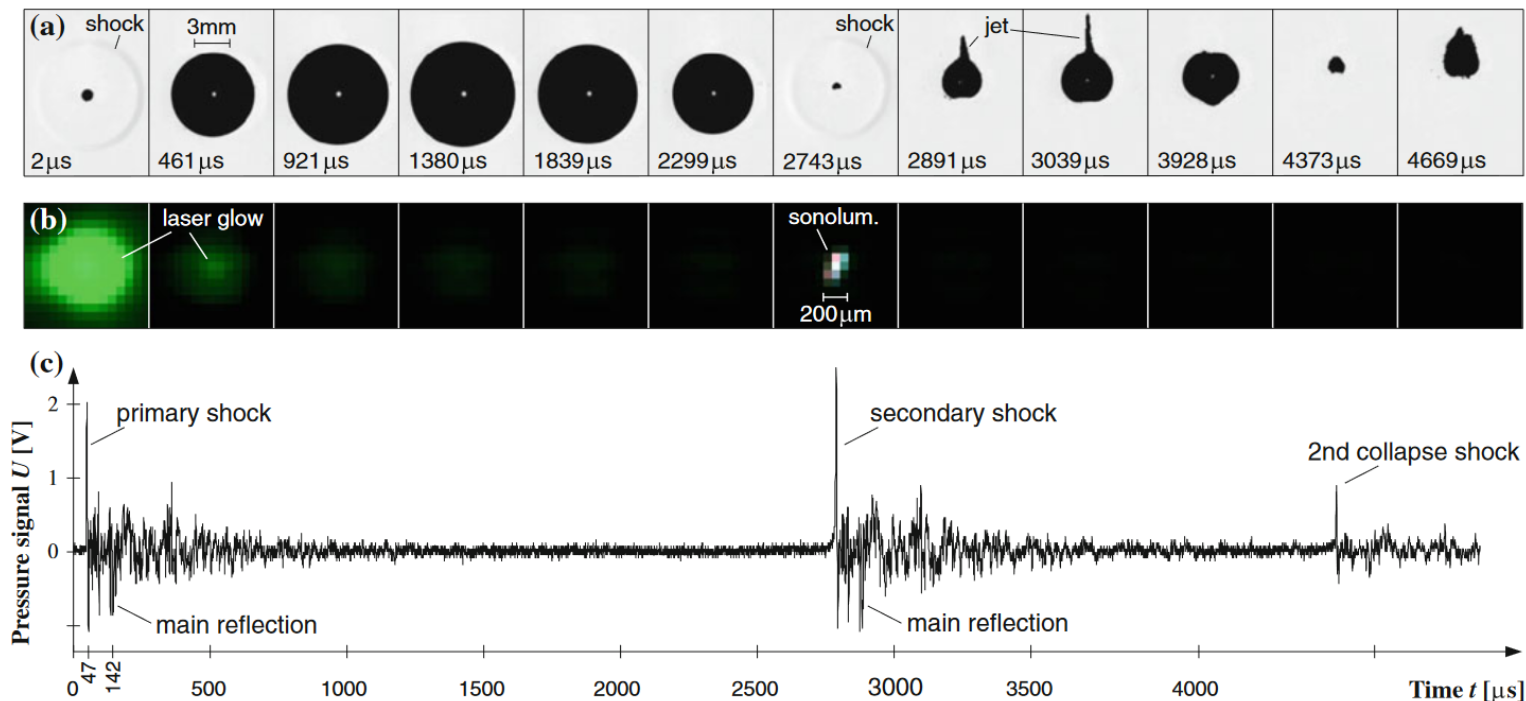

Cavitation induced luminescence

Sonoluminescence

Definition: Sonoluminescence is a conversion from « sound to light » by collapsing gas bubbles trapped in an acoustic pressure field

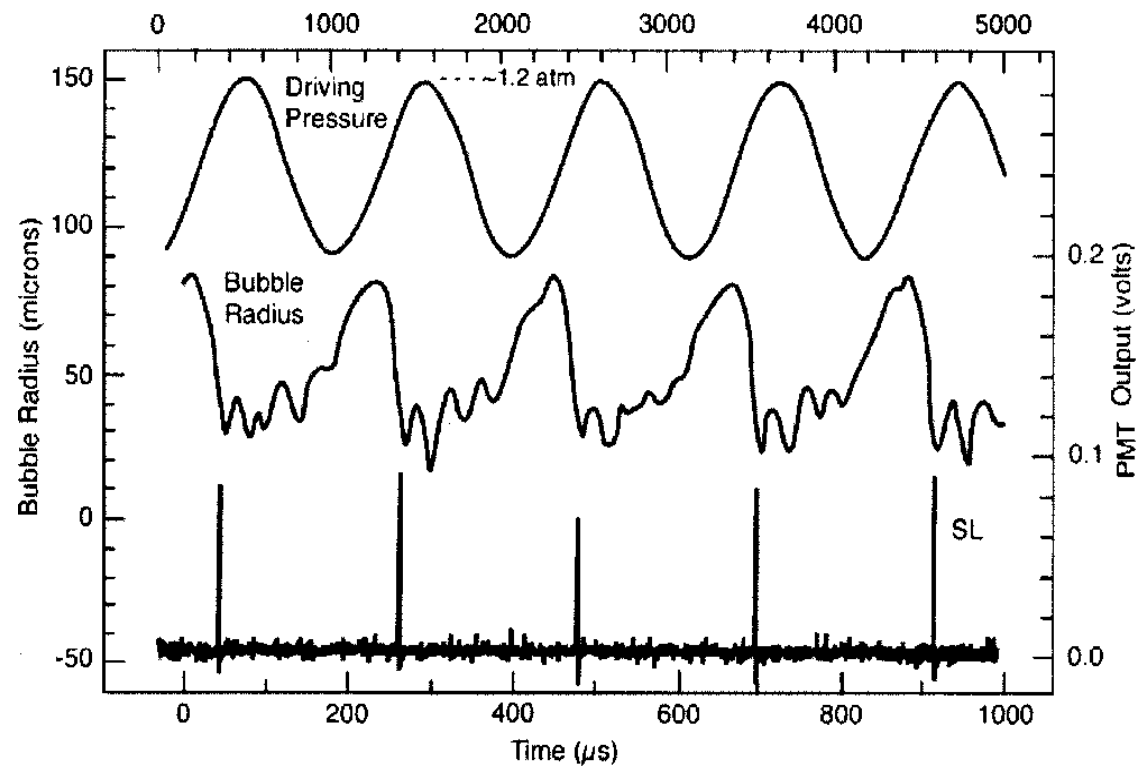

Light emission by repeated collapses of cavitation bubble collapses

Brenner et. al (2002)

Cavitation induced luminescence

Sonoluminescence

- **1933: Discovery of sonoluminescence by N. Marinesco and J. J. Trillat**
 - **Developing of photographic films immersed in a liquid excited by ultrasound**
- **1934: 1st visual observation of sonoluminescence**
 - **(H.Frenzel Frenzel and H. Schultes)**
- **1988: 1st theoretical model of acoustically excited bubbles (H. G. Flynn)**
- **1989: F. Gaitan discovers a laboratory method to generate a periodic luminescence (Single Bubble Sonoluminescence, SBSL)**

Cavitation induced luminescence Sonoluminescence

- Single Bubble Sonoluminescence, SBSL
 - Moderate pressure standing waves in a spherical tank

$$p(t) = p_a(1 + \alpha \cos 2\pi ft)$$

$$\alpha \sim 1.2 - 1.4; f \sim 20\text{kHz} - 40\text{kHz}$$

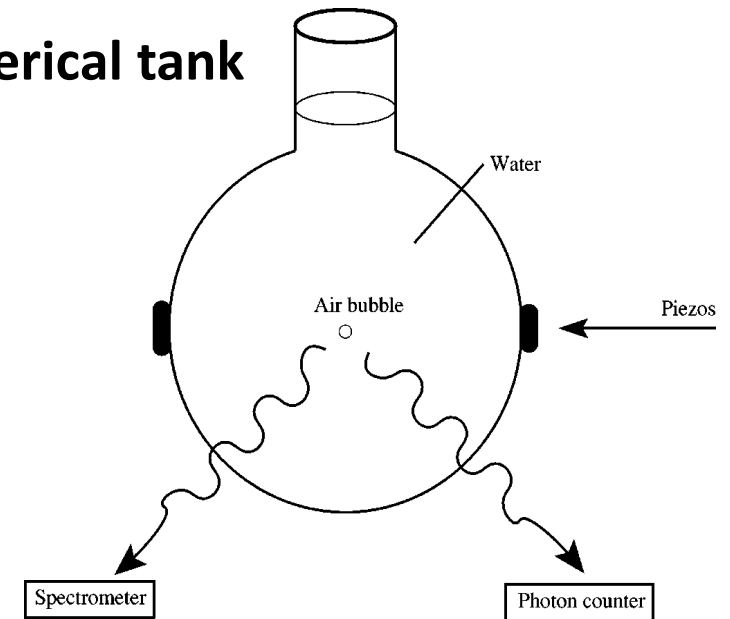

Brenner et. al (2002)

- Water at ~20% of air saturation
- Air bubble (~20 μm) trapped in the center of the tank by acoustic levitation
- The bubble oscillates in the radial direction
- A permanent light point is visible in the center of the tank

Cavitation induced luminescence

Sonoluminescence

- **Origin of luminescence**
 - High energy concentration at the bubble collapse (compressed gas)
 - Spherical converging shock wave (inside the bubble) ?
 - Adiabatic heating of the bubble contents → light emission
 - Generation of free radicals of which the recombination generates photon emission
- **Governing parameters:**
 - Type and concentration of dissolved gas
 - *Luminescence may be dopped by replacing air with Argon or Xenon*
 - Amplitude of the acoustic pressure
 - Liquid temperature
 - Impurities

Cavitation induced luminescence

Sonoluminescence

- Luminescence and nuclear fusion
 - Spectacular increase in gas temperature
 - First estimations based on spectral analysis of light: $T \sim 100'000'000 \text{ K}$
 - Potential for nuclear fusion reaction ?
 - Booming research on luminescence in the 1990's
 - 2002: Taleyarkhan et al. announced that they realized a nuclear fusion from a sonoluminescing bubble in acetone and detected neutron and tritium.
 - Since then, only one researcher (Yiban Xu, former PhD student of Taleyarkhan), pretended in 2005 that he was able to reproduce this experiment.

Cavitation induced luminescence

Sonoluminescence

- **Luminescence and nuclear fusion**
 - **Thanks to more accurate measurement techniques, the temperature estimation at the center of the bubble was brought down to 5'000 - 50'000 K**
 - **A fraud suspicion weighs heavily on the works of Taleyarkhan and Xu with negative consequences on the research funding**
 - **Nevertheless, research remains active in the field with the use of acetone and giant sonoluminescing bubbles (centimetric scale)**

From Wikipedia, the free encyclopedia

Rusi P. Taleyarkhan is a nuclear engineer and **academic fraudster** who has been a faculty member in the Department of Nuclear Engineering at [Purdue University](#) since 2003. Prior to that, he was on staff at the [Oak Ridge National Laboratory \(ORNL\)](#) in [Oak Ridge, Tennessee](#). He obtained his [Bachelor of Technology](#) degree in [mechanical engineering](#) from the [Indian Institute of Technology, Madras](#) in 1977 and [MS](#) and [PhD](#) (Nuclear Engineering and Science) degrees from [Rensselaer Polytechnic Institute \(RPI\)](#) in 1978 and 1982 respectively. He also holds an [MBA \(Business Administration\)](#) from [RPI](#).^[1]

In 2008, he was judged guilty of [research misconduct](#) for "falsification of the research record" by a Purdue review board.^[2]

Contents [hide]

- 1 [Sonofusion work and controversy](#)
- 2 [See also](#)
- 3 [References](#)
- 4 [Further reading](#)
- 5 [External links](#)

Sonofusion work and controversy [edit]

In 2002, while a senior scientist at ORNL, Taleyarkhan published a paper on fusion achieved by bombarding a container of liquid solvent with strong **ultrasonic** vibrations, a process known as sonofusion or **bubble fusion**. In theory, the vibrations collapsed gas bubbles in the solvent, heating them to temperatures high enough to fuse hydrogen atoms and release energy. Following his move from Oak Ridge to Purdue in 2003, Taleyarkhan published additional papers about his research in this area.

Numerous other scientists, however, were not able to replicate Taleyarkhan's work, including in published articles in *Physical Review Letters* from the [University of Göttingen](#), from [UCLA](#), from [University of Illinois](#), from former colleagues at Oak Ridge National Labs, and a study funded by the [Office of Naval Research](#) in the [University of California](#).^[3]

Taleyarkhan's results were reportedly repeated by Edward Forringer of [LeTourneau University](#) in Taleyarkhan's own labs at Purdue in November 2006.^[4] Purdue decided at that time not to further investigate the initial narrowly defined charges of misconduct against Taleyarkhan made by other members of the Purdue Faculty.^[5]

The *Chronicle of Higher Education*, however, has noted some problems with the verification. "During this time, Dr. Taleyarkhan says, two more scientists came into his laboratory and independently verified bubble fusion. Dr. Taleyarkhan contends that both were experts and did their work independently of him. But in interviews, both researchers contradict aspects of that account. One of those scientists, Edward R. Forringer, a professor of physics at LeTourneau University, in Texas, says he is certainly not an expert. Nonetheless, he says he is confident that his results do support the reality of bubble fusion."^[6] Forringer, however, did not publish his purported confirmation in any refereed journal.

On May 10, 2007, Purdue announced that they would add at least one scientist without ties to the university to a new inquiry of Taleyarkhan and his work, at the insistence of a [Congressional](#) panel investigating the use of federal funds in attempts to reproduce Taleyarkhan's results. The panel cited concerns that Taleyarkhan's claims of independent verification were "highly doubtful", and criticized Purdue for using three of the same members of an earlier inquiry committee in their recently completed review. Taleyarkhan called the report a "one-sided, grossly exaggerated write-up" but agreed to cooperate.^[7] On September 10, 2007, Purdue reported that its internal committee had determined that "several matters merit further investigation" and that they were re-opening formal proceedings.^[8]

This board judged him guilty of "research misconduct" for "falsification of the research record" in July 2008^[2] and on August 27, 2008 his status as a member of the Purdue University Graduate Faculty was limited to that of 'Special Graduate Faculty.' He was permitted to serve on graduate committees, but would not be able to serve as a major professor or co-major professor for graduate students for a period of three years.^[9] Taleyarkhan received from September 2008 to August 2009 a \$185,000 grant from the [National Science Foundation](#) to investigate bubble fusion.^[3] In 2009 the [Office of Naval Research](#) debarred him for 28 months, until September 2011, from receiving U.S. Federal Funding.^{[3][10]} During that period his name was listed in the 'Excluded Parties List' to prevent him from receiving grants from any government agency.^[3]



Professor Rusi Taleyarkhan at Oak Ridge, showing a bubble fusion system

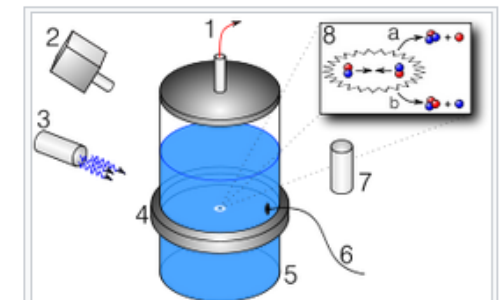

Sonofusion device used by Rusi Taleyarkhan. 1. Vacuum pump 2. Liquid scintillator 3. Neutron source 4. Acoustic wave generator 5. Test chamber with fluid 6. Microphone 7. Photomultiplier tube 8. Two deuterium atoms collide 8a. Possible fusion event creating Helium and a neutron 8b. Possible fusion event creating Tritium and a proton



Rusi Taleyarkhan est un physicien et ingénieur nucléaire d'origine indienne, surtout connu pour ses recherches controversées dans les années 2000 sur la "fusion par cavitation" ou la "fusion par bulles" (**bubble fusion** en anglais). Taleyarkhan a affirmé avoir réussi à produire des réactions de fusion nucléaire à température ambiante en utilisant des bulles de cavitation dans un liquide, une revendication qui a suscité de nombreuses controverses et un intense débat scientifique.

Son Expérience et Ses Travaux

1. **Études et carrière** : Taleyarkhan a été formé en ingénierie nucléaire et a travaillé dans plusieurs institutions prestigieuses, notamment les laboratoires d'Oak Ridge aux États-Unis, avant de devenir professeur à l'université Purdue, dans l'Indiana.
2. **Expérience en fusion par cavitation** : En 2002, Taleyarkhan et son équipe ont publié un article dans la revue *Science* affirmant qu'ils avaient produit des preuves de fusion nucléaire en utilisant un procédé qui consistait à créer des bulles de gaz dans un liquide et à les faire imploser avec des ondes sonores. L'énergie de l'implosion aurait permis, selon eux, de provoquer une réaction de fusion, même si celle-ci ne produisait que de très faibles quantités d'énergie.

Controverse et Réactions de la Communauté Scientifique

Les résultats de Taleyarkhan ont suscité beaucoup de scepticisme dans la communauté scientifique. Plusieurs chercheurs ont essayé de reproduire ses expériences sans succès, et des enquêtes ont été menées pour vérifier la validité de ses résultats.

1. **Enquête et accusations** : Au fil des ans, les travaux de Taleyarkhan ont fait l'objet de plusieurs enquêtes internes à l'université Purdue et d'autres institutions. Il a été accusé d'inconduite scientifique, notamment de falsification de données et de mauvaise présentation des résultats de ses expériences.
2. **Retrait de publications** : En 2008, certains de ses articles ont été retirés des publications scientifiques, et l'université Purdue a finalement conclu qu'il avait effectivement commis des fautes scientifiques. Taleyarkhan a contesté ces conclusions, affirmant que ses recherches étaient légitimes et que les accusations faisaient partie d'une campagne contre lui.

La Fusion par Cavitation Aujourd'hui

L'idée de la fusion par cavitation n'est pas totalement écartée en physique nucléaire, mais les travaux de Taleyarkhan n'ont pas été confirmés de manière reproductible. Ses expériences restent controversées, et la fusion par bulles n'est pas considérée comme une source fiable de fusion nucléaire. La fusion par cavitation est parfois considérée comme une branche de la recherche sur la fusion froide, elle-même sujette à controverse depuis les années 1980.

Conclusion

Rusi Taleyarkhan reste une figure marquante pour ses recherches et pour le débat qu'il a suscité autour de la fusion à température ambiante. Ses travaux ont mis en lumière les défis de la validation scientifique et l'importance de la reproductibilité en recherche, surtout pour des phénomènes aussi complexes que la fusion nucléaire.

Luminescence induced by a collapsing bubble

Evidence of light emission at the final stage of the collapse of a highly spherical bubble (10 million frames per second, 50 ns exposure time)

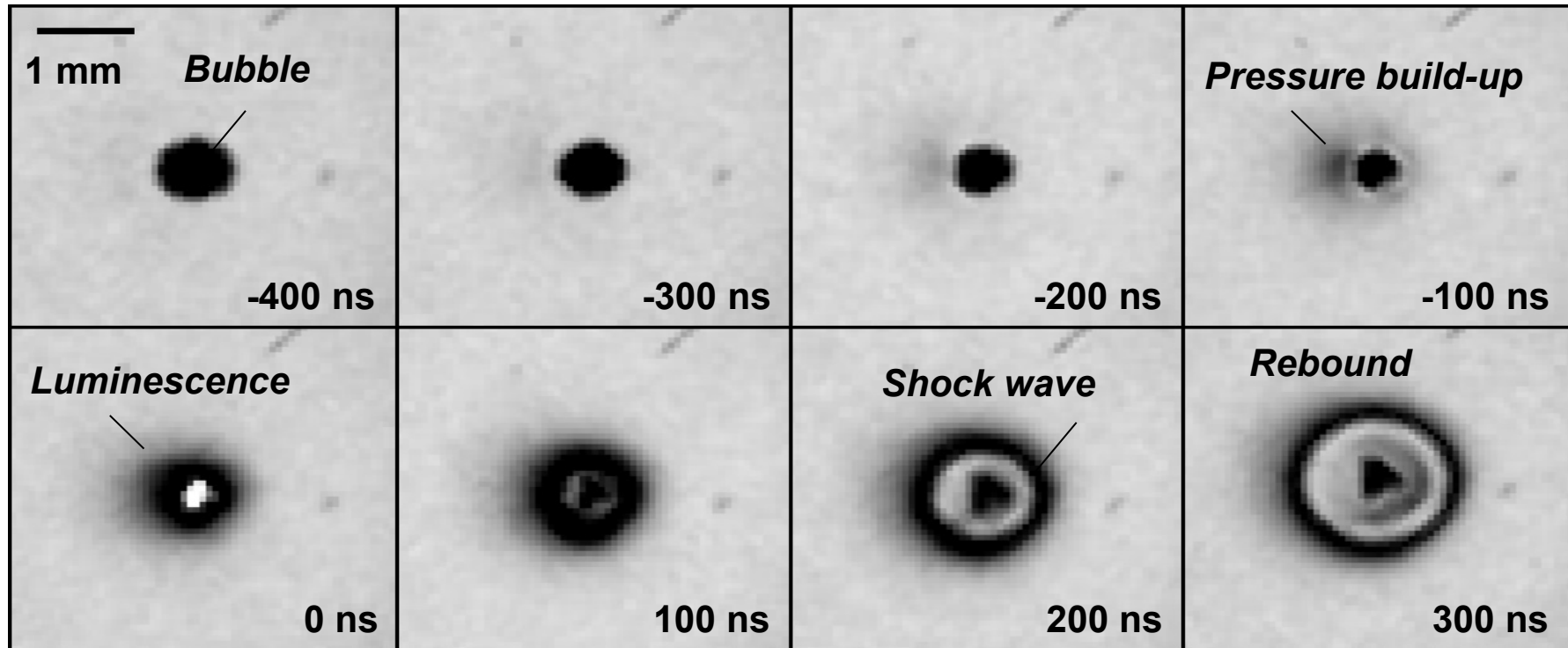

Collapse induced Luminescence

- **Effect of bubble deformation on luminescence emission**
 - **Threshold for luminescence \sim Weak jet limit ($\zeta \sim 10^{-3}$)**

Visualization of luminescence emitted at the final collapse stage of a single cavitation bubble at various ζ . The luminescent flash is visible in the middle frame and followed by the rebound. The inter-frame time is 100 ns, the exposure time is 50 ns and the black bar shows the 1 mm scale. The bubble energy is the same in all cases ($E_0 \sim 27$ mJ) and ζ varied by adjusting the driving pressure, from top to bottom, as $\Delta p = 98, 78, 58, 48, 28$ and 18 kPa, yielding maximum bubble radii of $R_0 \sim 4.1, 4.3, 4.8, 5.1, 6.1$ and 7.1 mm. These bubbles were imaged at normal gravity.

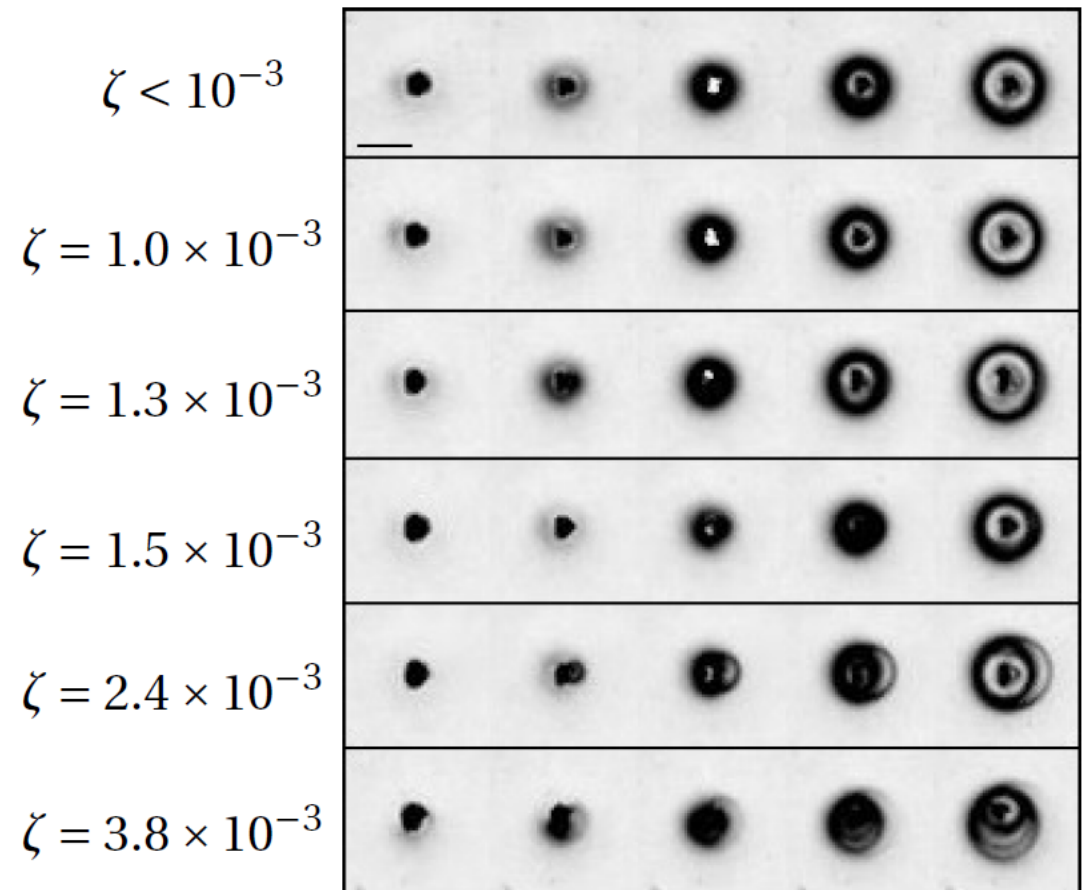

Collapse induced Luminescence

- Experimental setup for luminescence measurements
 - Light spectrum:
 - Spectrometer & Light grating lens

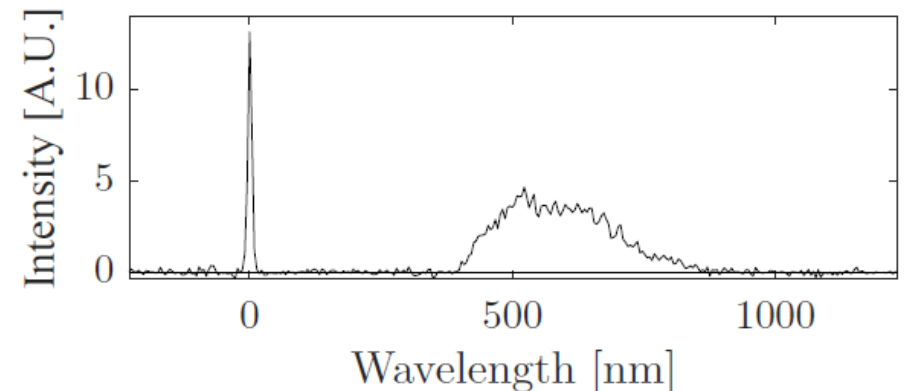
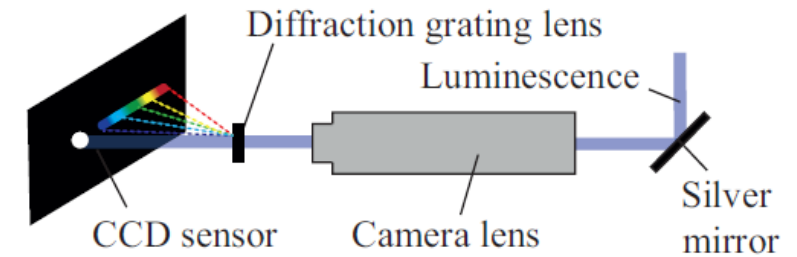
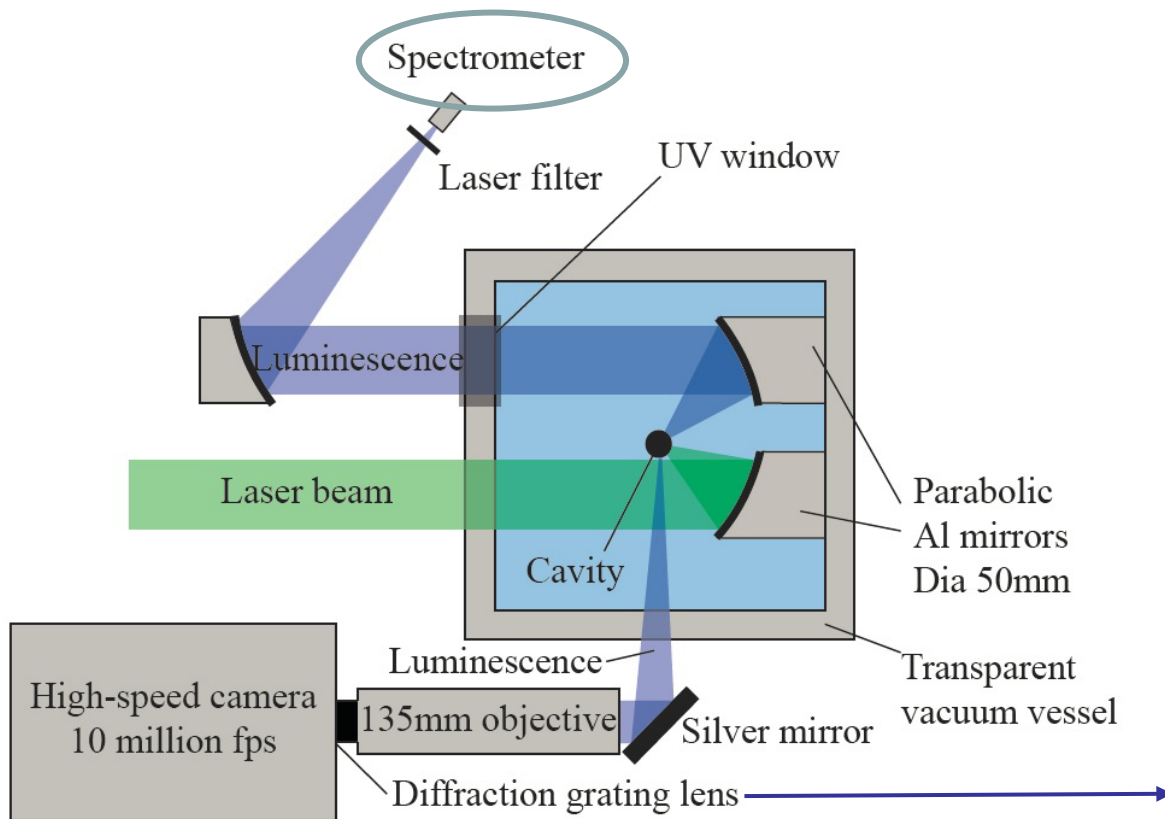

Collapse induced Luminescence

- Calibration

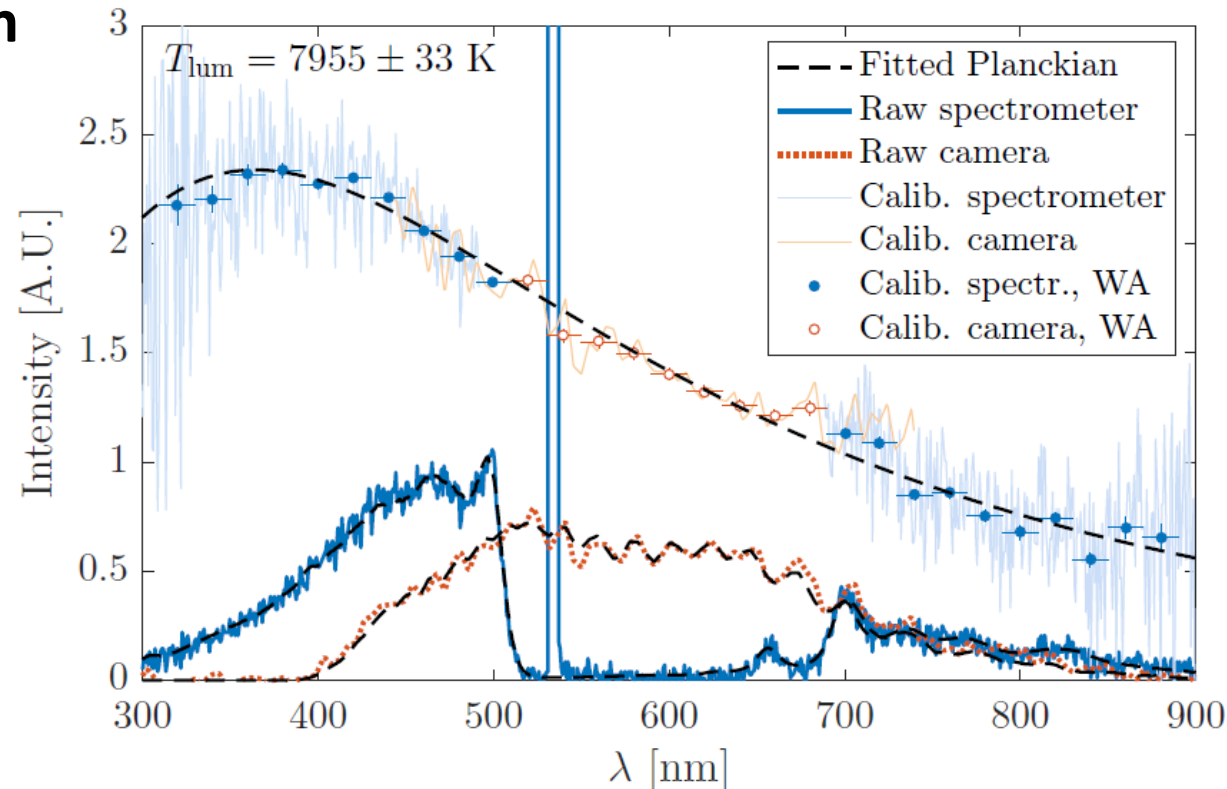

Figure 4.5: Typical luminescence spectrum from a single bubble collapse, measured with the spectrometer with an exposure time 8 ms and the high-speed CCD camera with an exposure time of 10 μ s. Both raw and calibrated spectra are shown, together with the fitted Planckians. Window averages (WA) of 20 nm-large windows are also displayed. The peak around 532 nm is caused by the strong laser pulse despite the > 99% attenuation of the filter. Here $R_0 = 3.0$ mm, $\Delta p = 78$ kPa and $|\mathbf{g}| = 1$ g.

Collapse induced Luminescence

- **Temperature estimation – Blackbody radiation assumption**

The luminescence spectrum is well approximated by the blackbody model and since the bubble temperature cannot be directly measured, a fitted blackbody provides a reasonable estimation for it. The effective blackbody temperature and energy of luminescence can be inferred by fitting the spectra with a Plankian function of the form:

$$L(\lambda, I, T_{\text{lum}}) = A \frac{I}{\lambda^5} \frac{1}{\exp\left(\frac{hc}{\lambda k_B T_{\text{lum}}}\right) - 1} \quad [\text{J}/\text{nm}]$$

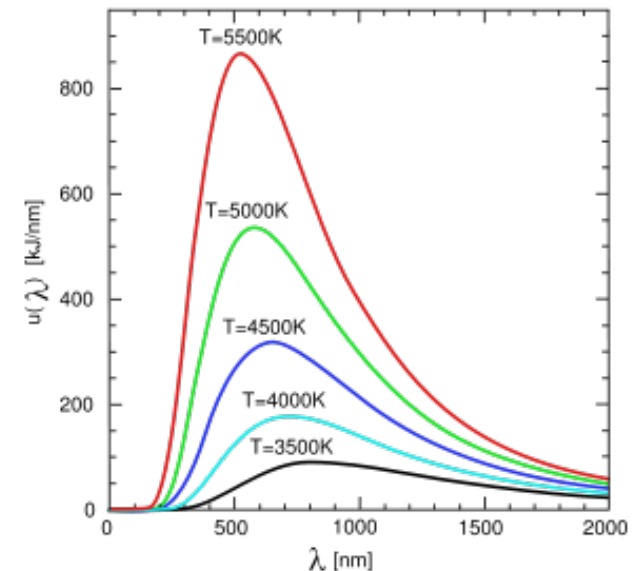

Where λ is the wavelength, h and k_B are the Planck and Boltzmann constants respectively, c is the speed of light, A is a constant prefactor determined from calibration, T_{lum} is the blackbody temperature, and I stands for the product of the luminescence pulse duration and the projected emitting surface.

Collapse induced Luminescence

- **Temperature estimation at different gravity levels**

Single cavitation bubble luminescence spectra at three different gravity levels for the same laser pulse energy ($R_0=3$ mm) and static pressure of the water ($p_0 = 81$ kPa). Each spectrum is measured at a single bubble collapse.

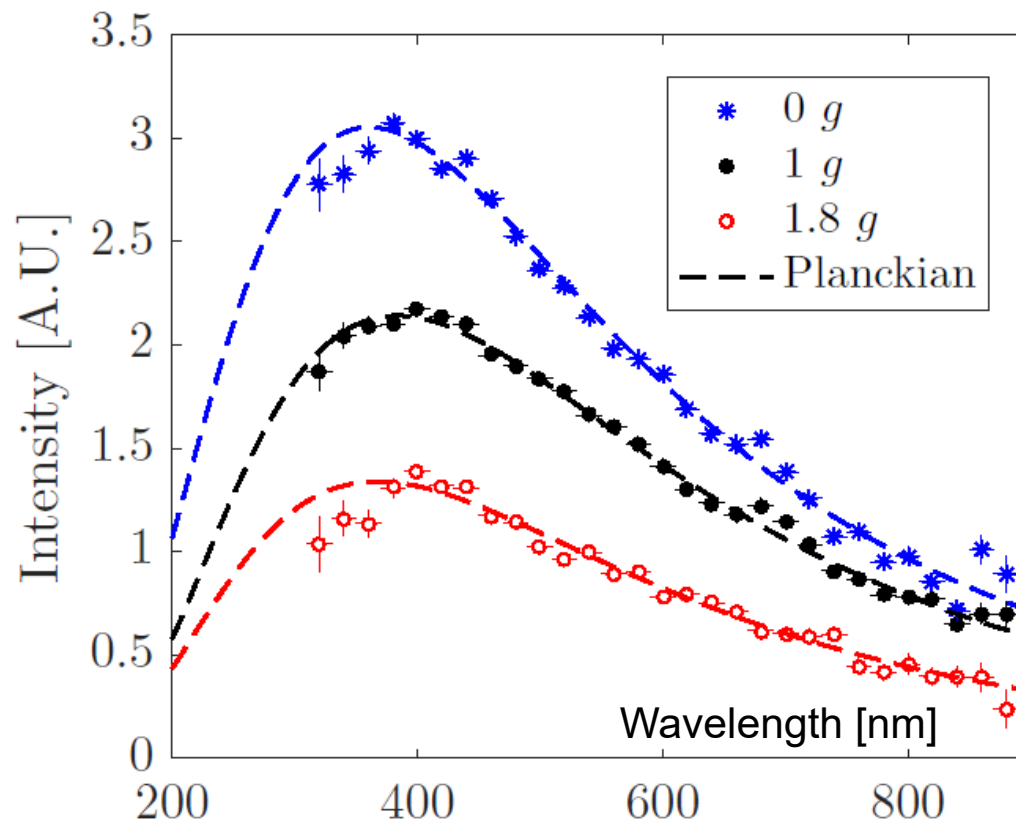

Collapse induced Luminescence

- Effect of bubble deformation on luminescence energy and temperature

Single cavitation bubble luminescence
 (a) relative energy E_{lum}/E_0 and
 (b) blackbody temperature T_{lum} vs ζ .

E_0 is the maximum potential energy of the bubble. Each data point represents a single bubble measurement. Colors indicate the driving pressures and symbols indicate different levels of gravity. The error bars indicate the uncertainty of the best-fit estimate of the blackbody temperature.

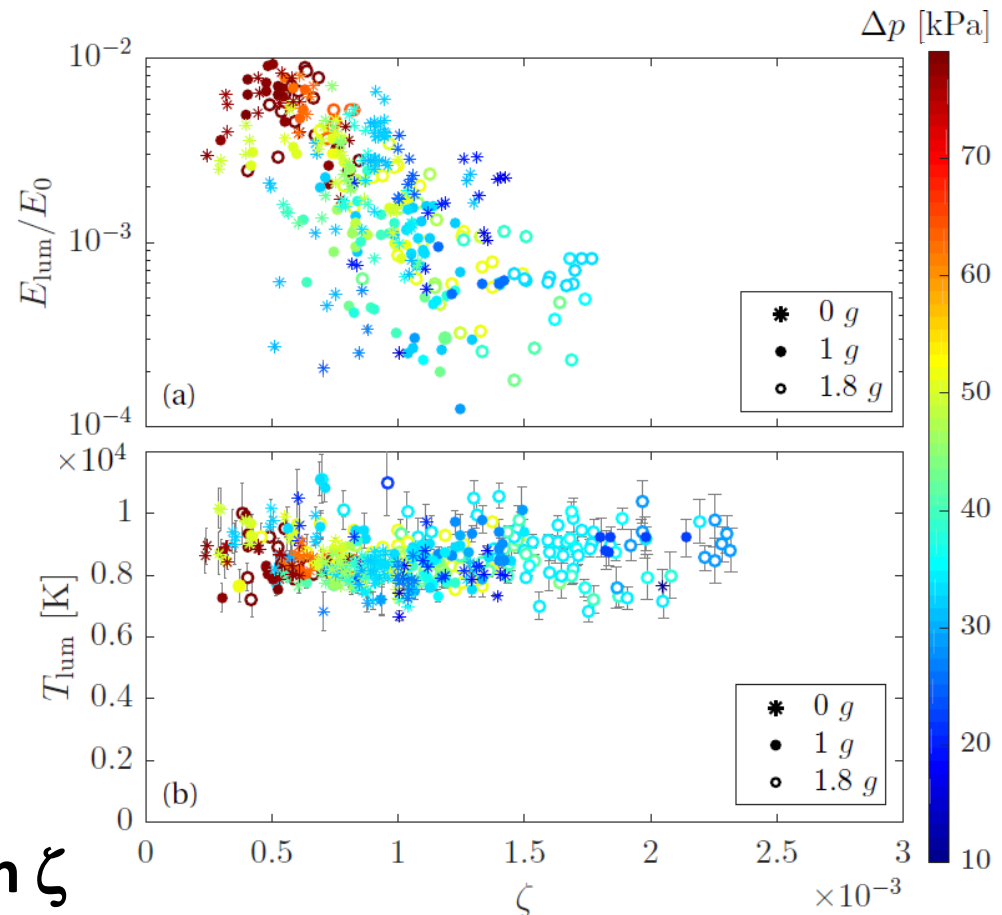

- Luminescence energy decreases with ζ
- Temperature saturation (no clear influence of ζ)

Collapse induced Luminescence

- Time resolved luminescence (measured by a fast photodiode)
 - Triggered by the passage of the collapse shock wave (Hydrophone)
 - 10-20 ns pulse duration
 - Single and multiple pulses (?)

Waterfall plots of the luminescence signals measured by the photodetector for different driving pressures and potential energy $E_0 \sim 22\text{mJ}$ (normal gravity):

	Δp [kPa]	R_0 [mm]	ζ [-]
(a)	98	3.8	7.8×10^{-4}
(b)	78	4.0	9.0×10^{-4}
(c)	68	4.2	9.9×10^{-4}
(d)	58	4.5	1.1×10^{-3}
(e)	48	4.7	1.3×10^{-3}
(f)	38	5.1	1.6×10^{-3}

Each plot contains 20 signals. The scaling shown in (a) is the same in all plots. $t=0 \mu\text{s}$ corresponds to the instant at which the hydrophone detects the collapse shock.

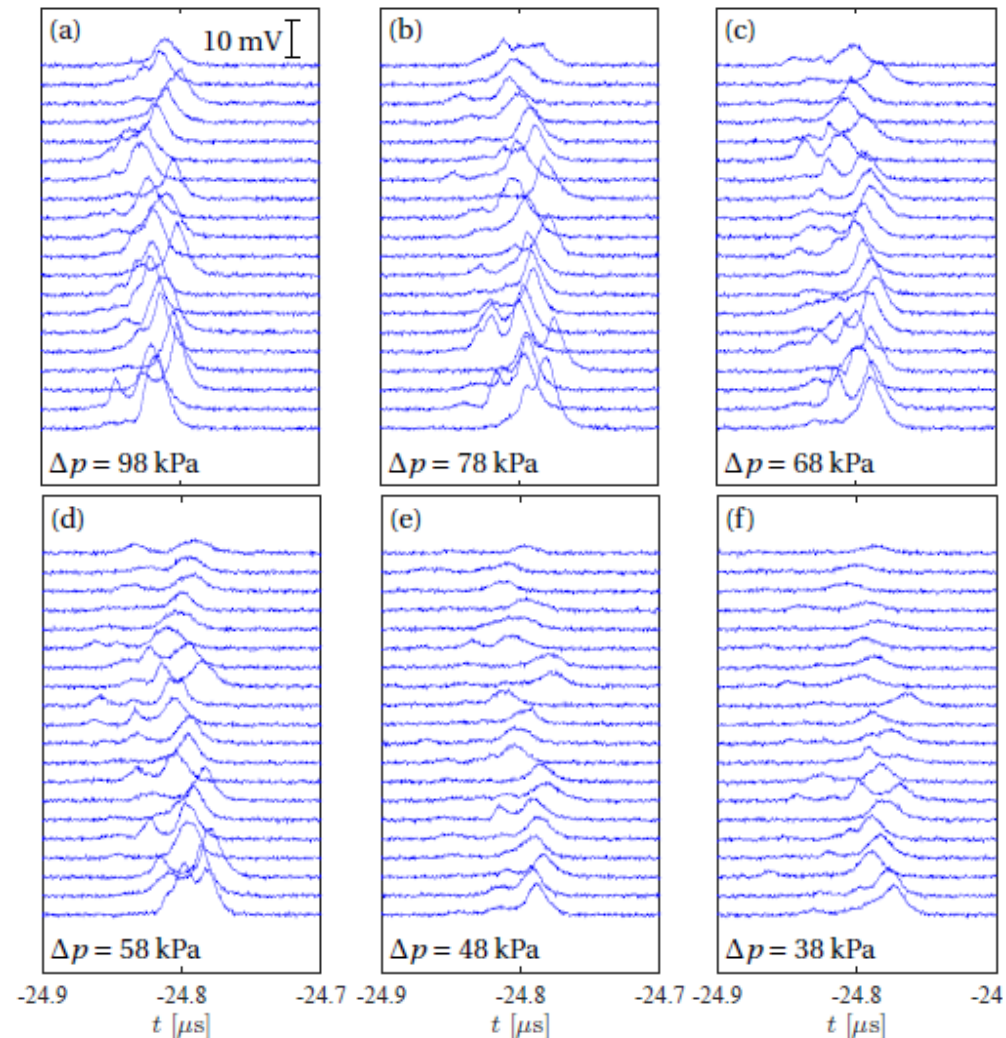

Initial question:

Energy budget: Where does the energy of a collapsing bubble go ?

- Microjet
- Shock waves
- Luminescence
- Rebound

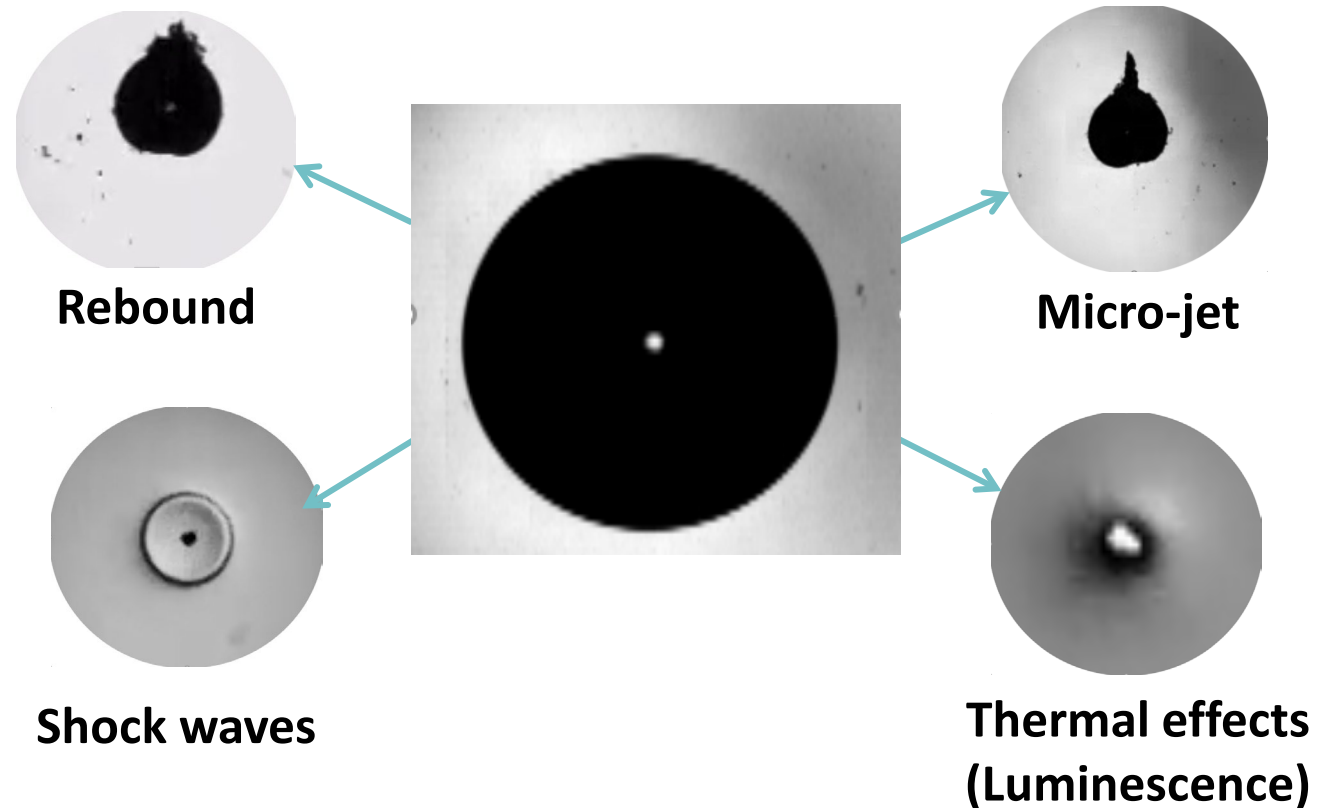

Energy budget for a laser induced bubble

- Energy of shockwave, rebound, luminescence and micro-jetting as functions of the anisotropy and stand-off parameters :
 - Broad parameter space (max bubble radius, driving pressure, solid and free neighboring surfaces, different gravity levels, ...)

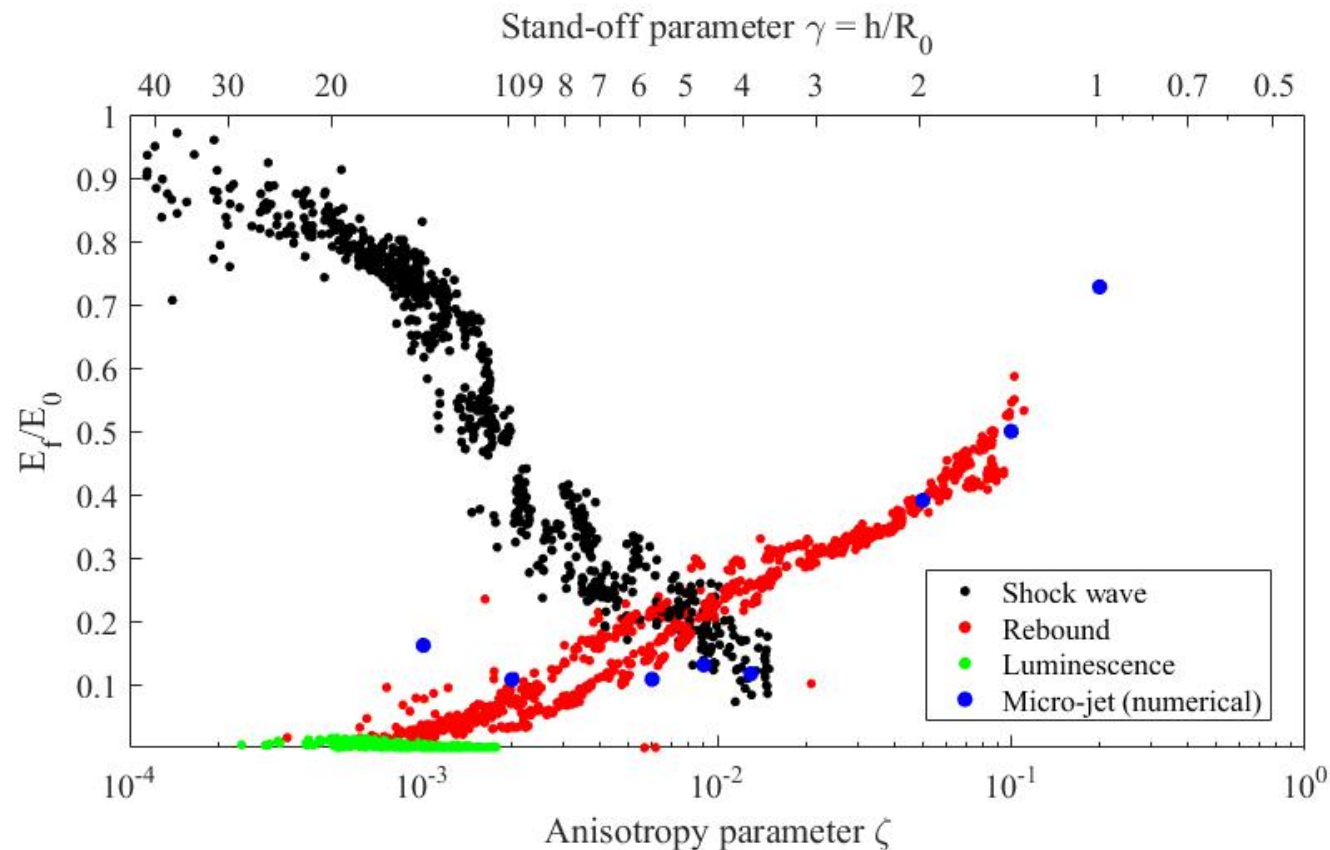

- Luminescence energy negligible compared to the other energy channels