

The background image is a composite of two scenes. On the left, a traditional wooden windmill stands on a grassy bank next to a body of water, with power lines visible in the sky. On the right, a large industrial cooling tower is visible, partially obscured by a semi-transparent red rectangular overlay. The sky is a mix of blue and light pink, suggesting a sunset or sunrise.

ME-446: Liquid-gas interfacial heat and mass transfer

Zhengmao Lu
Energy Transport Advances
Laboratory
EPFL Mechanical Engineering

2025 Fall Semester

Photo Credit: Trougnouf



- I'm Zhengmao Lu (zhengmao.lu@epfl.ch)
 - Phase change heat transfer, interfacial phenomena, micro/nano, cooling
 - 22 years in China; 10 years in the US; Joined EPFL in February 2023

- Teaching Assistant: Gautier Rouaze (gautier.rouaze@epfl.ch)

Leverage liquid-gas interfacial transport to address the challenge of sustainability

Generation

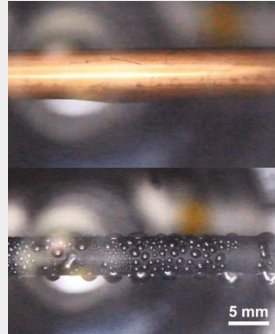

Condensation

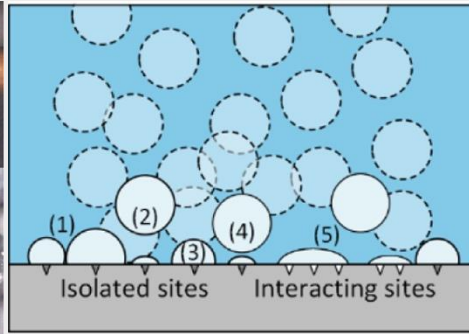

Boiling

Storage

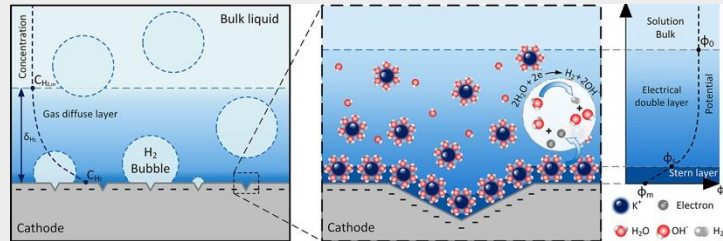

Alkaline water electrolysis

Usage

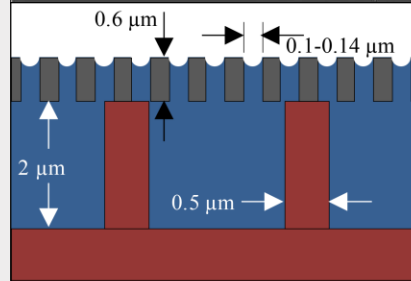
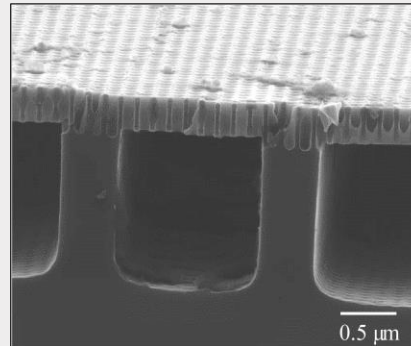

Electronics cooling

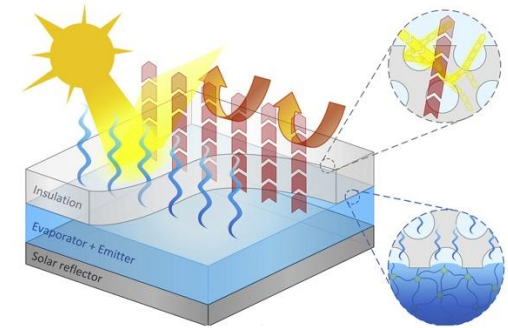
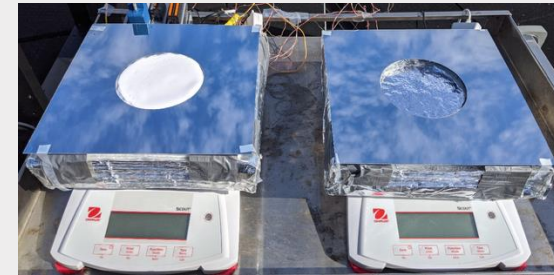

Passive building cooling

Broad Application of Liquid-Gas Interfacial Transport

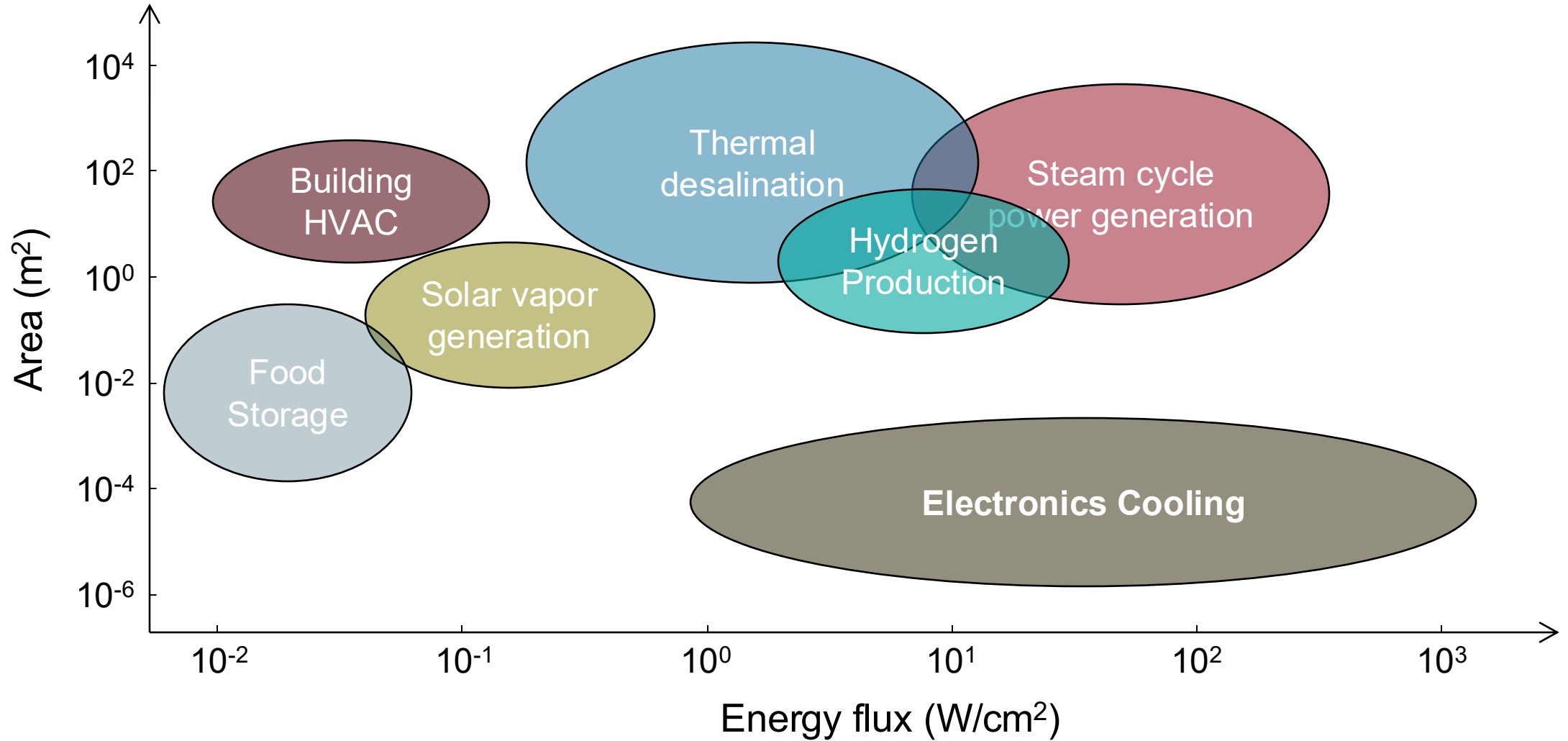

Current Research Activities

Length scale



nanometer

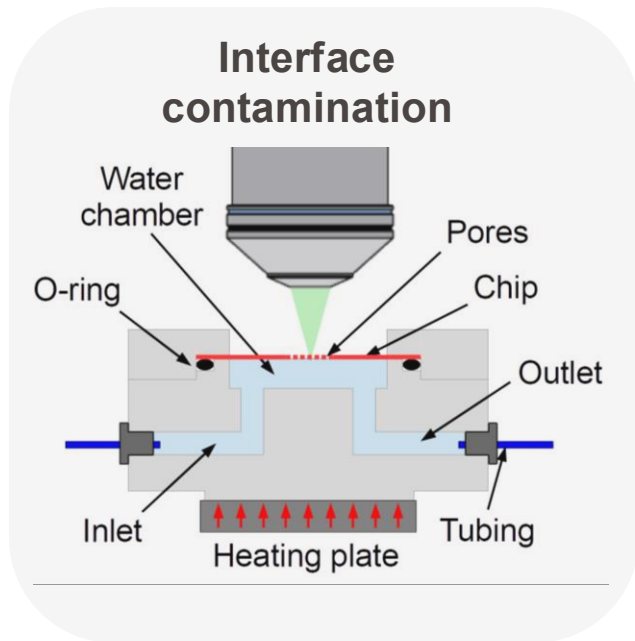

millimeter

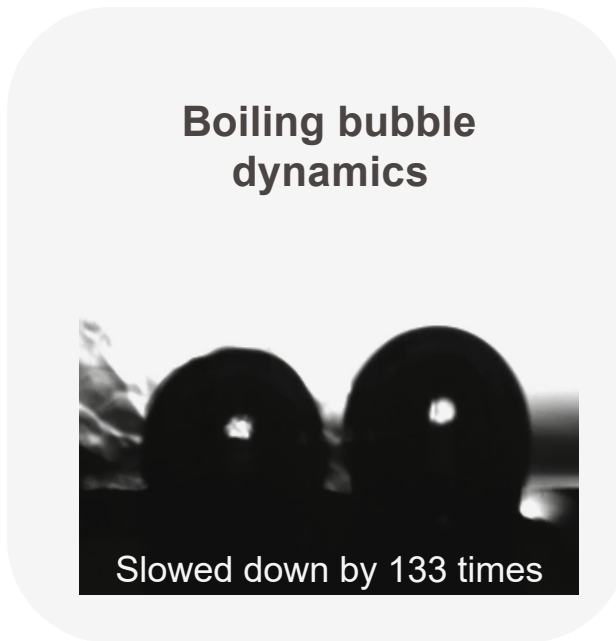

meter

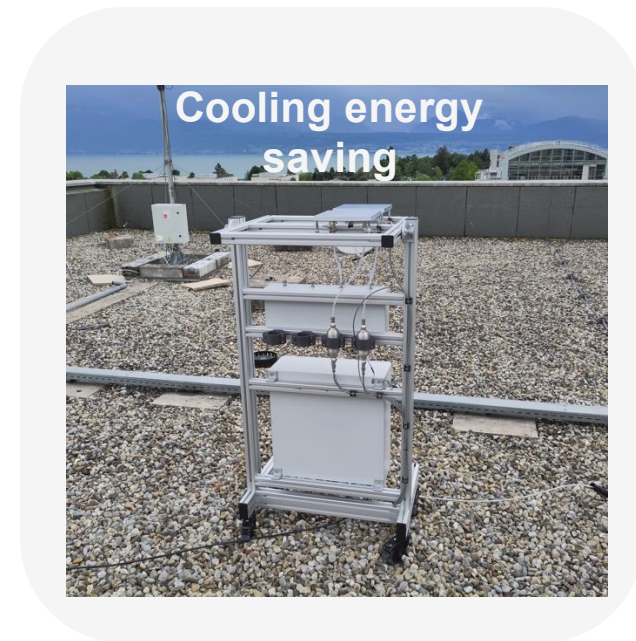



- Lectures
 - Thursday (08:15-10:00); we'll have a 15-minute break at 9h.

- Exercises
 - Thursday (10:15-11:00)

- Moodle
 - Important course info will be announced through Moodle

- Office hour
 - Thursday one hour after the exercise



- Homework presentation 25%
 - In each week's exercise session, 3-4 of you will form a HW group, work together on a problem set, and present your solution to the class.
 - We will post a Google Sheet of the HW group with preassigned names on Moodle, but feel free to trade slots.
 - The rest of the class is also expected to work on the same problem set prior to the exercise session. Solution will be posted the week after for self-correction.
 - For the HW presentation, you get the full score if you show reasonable amount of effort regardless whether you get the correct answer.

- Journal presentation 25%
 - We will post several recent papers in the area of liquid-gas interfacial phenomena. You can sign up for the one in which you are most interested.
 - People who choose the same paper form a JP group. Each group has a size limit based on the specific paper. The sign-up sheet and the papers will be posted later in the semester, first come first service.
 - In the two weeks before the last lecture week, each JP group will give an oral presentation (presentation period = group size x 5 min + 5 min Q&A)
 - I will evaluate your presentation based on whether you show reasonable amount effort to understand and communicate your understanding to the audience.

- Final Exam 50%
 - Will be closely related to exercise problems
 - There will be a review session in the last week of the semester.



- We will organize a tour of the ETA-Lab in Week 10 (to be confirmed)

- **Carey**, V. P. (Van P.). Liquid-Vapor Phase-Change Phenomena: An Introduction to the Thermophysics of Vaporization and Condensation Processes in Heat Transfer Equipment. Third edition. Boca Raton: CRC Press, 2020.
- **Lienhard IV**, John H, and John H Lienhard V. A Heat Transfer Textbook. 5th ed. Mineola (N.Y.): Dover Publications, 2019.
- **Bird**, R. Byron, Warren E Stewart, and Edwin N Lightfoot. Transport Phenomena. Rev. 2nd ed. New York: Wiley, 2007.

Evaporation



Boiling



Condensation



Film

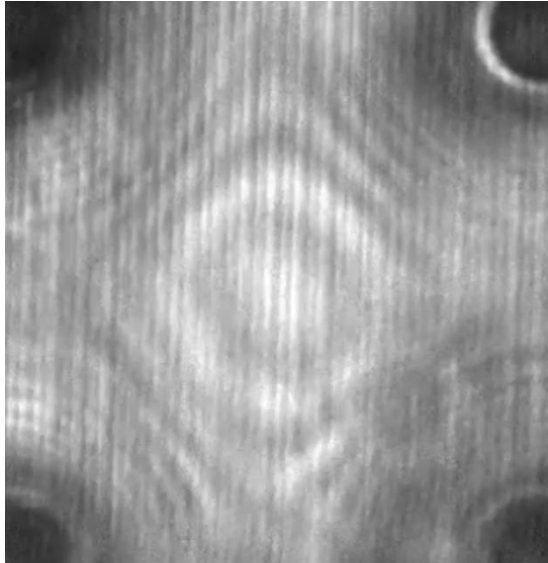

Langmuir 2016 32 (2), 519-526

Bubble

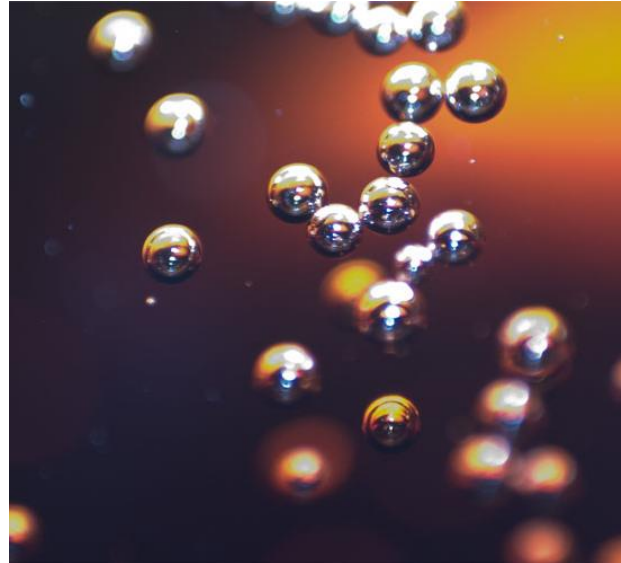

Credit: Spiff

Droplet



Credit: Jesse Marino

Heat and mass transfer across liquid-gas interfaces as phase change occurs

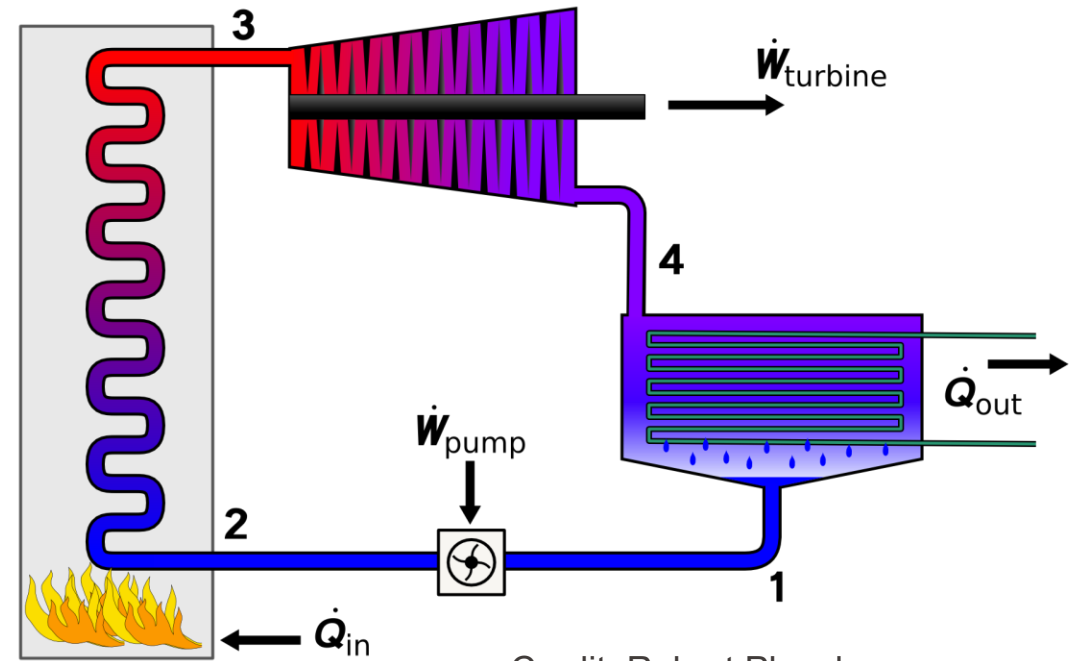

Boiling and condensation play critical roles in power generation

SCI
AM Scientific American

The Summer of 2023 Was the Hottest in 2,000 Years

Ancient tree rings show that the summer of 2023 was the hottest in the past 2000 years because of human-caused climate change.

14 May 2024



... BBC

Summer 2024 was world's hottest on record

Summer 2024 was the Earth's warmest on record, according to the Copernicus Climate Change Service. It was also the warmest across Europe at...

5 days ago



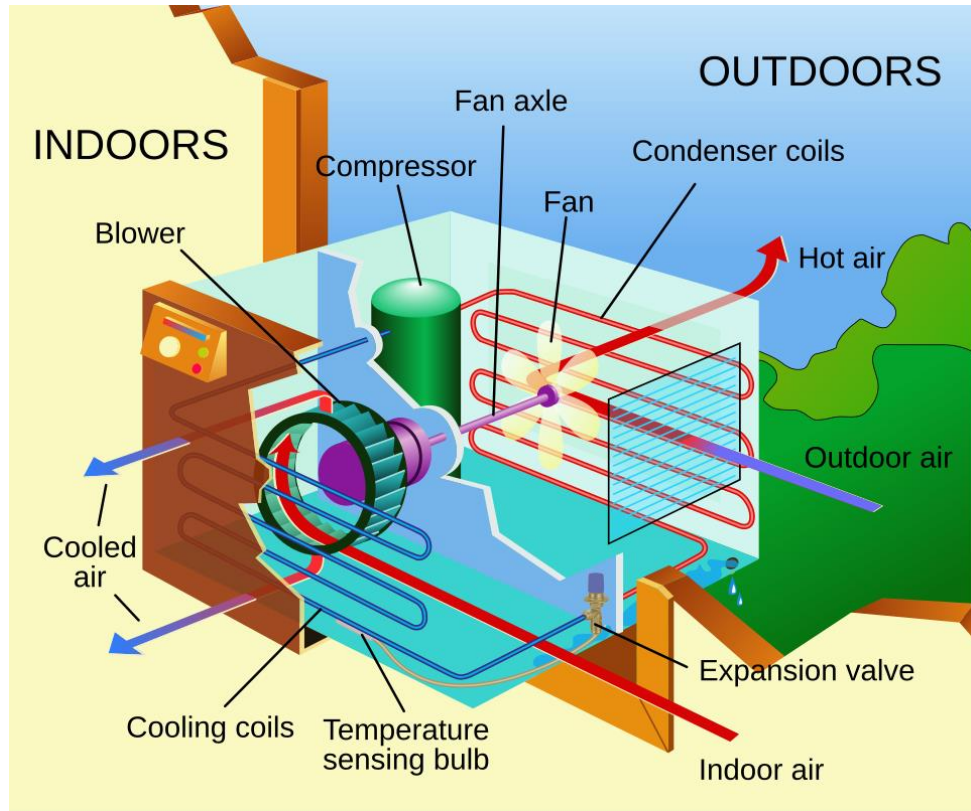

Evaporators and condensers are key components of air conditioning and refrigeration systems

Source: The New Book of Knowledge 1997. p.102

Electronics cooling critical for device performance and reliability

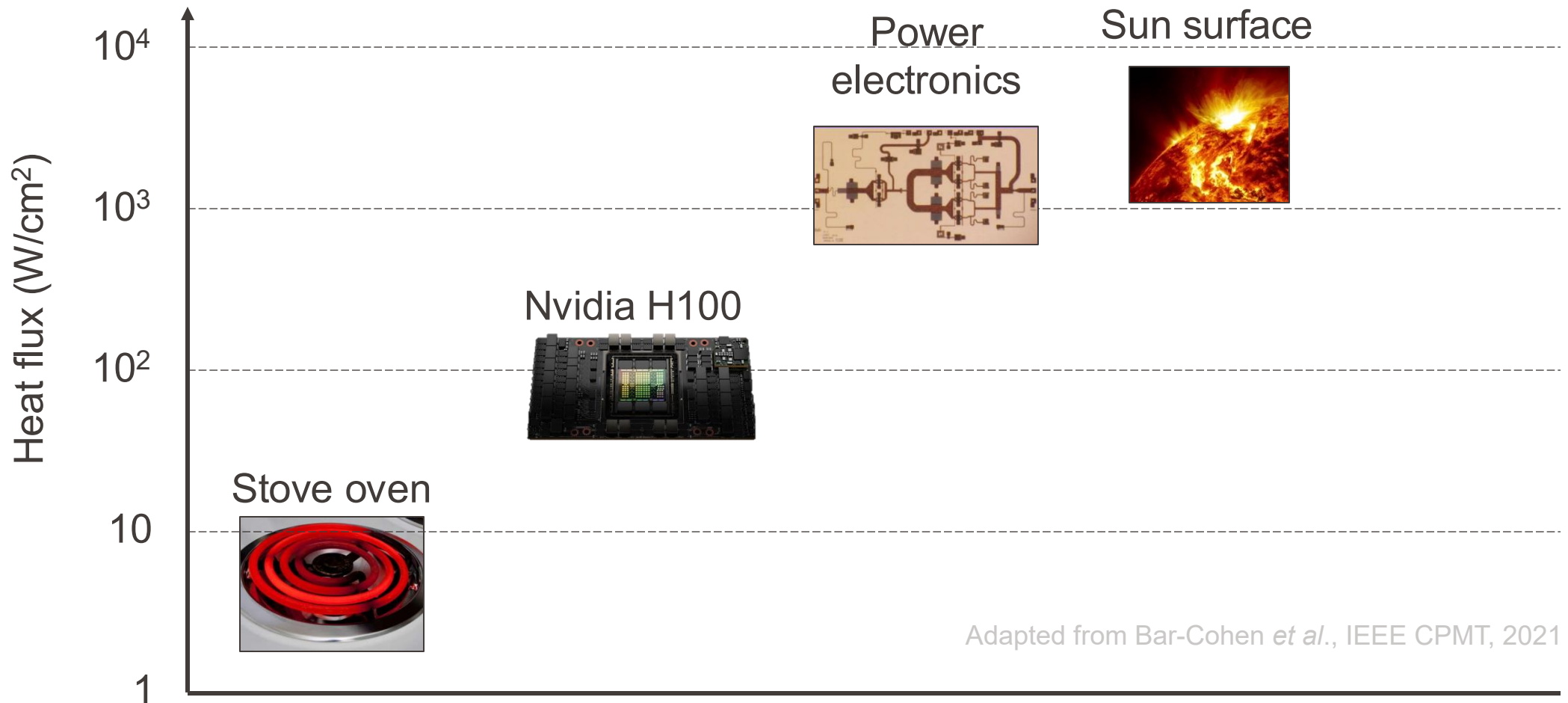

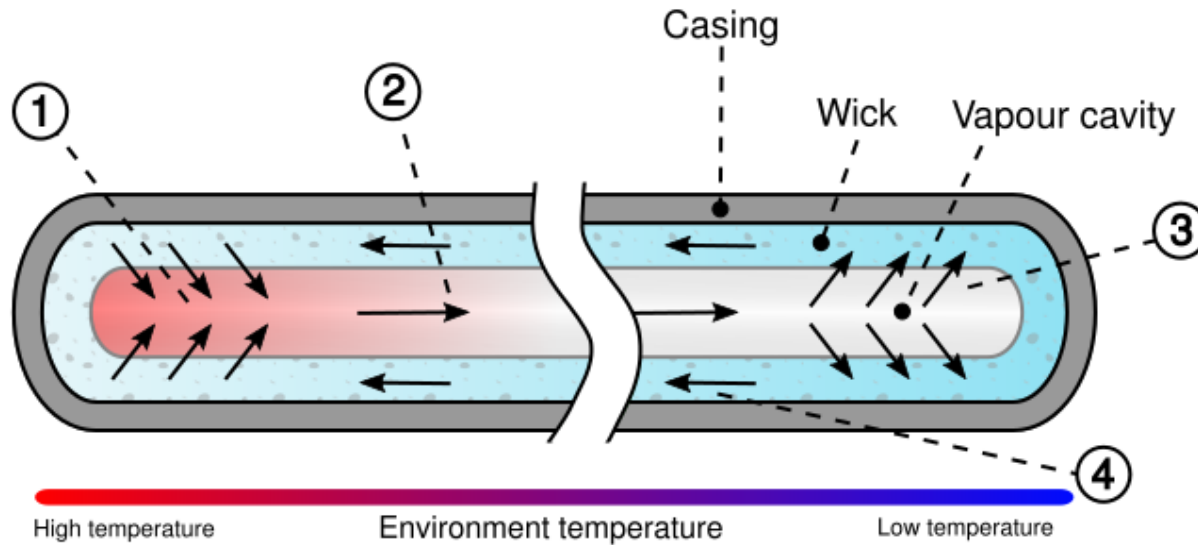

Heat pipe thermal cycle

- 1) Working fluid evaporates to vapour absorbing thermal energy.
- 2) Vapour migrates along cavity to lower temperature end.
- 3) Vapour condenses back to fluid and is absorbed by the wick, releasing thermal energy.
- 4) Working fluid flows back to the higher temperature end.

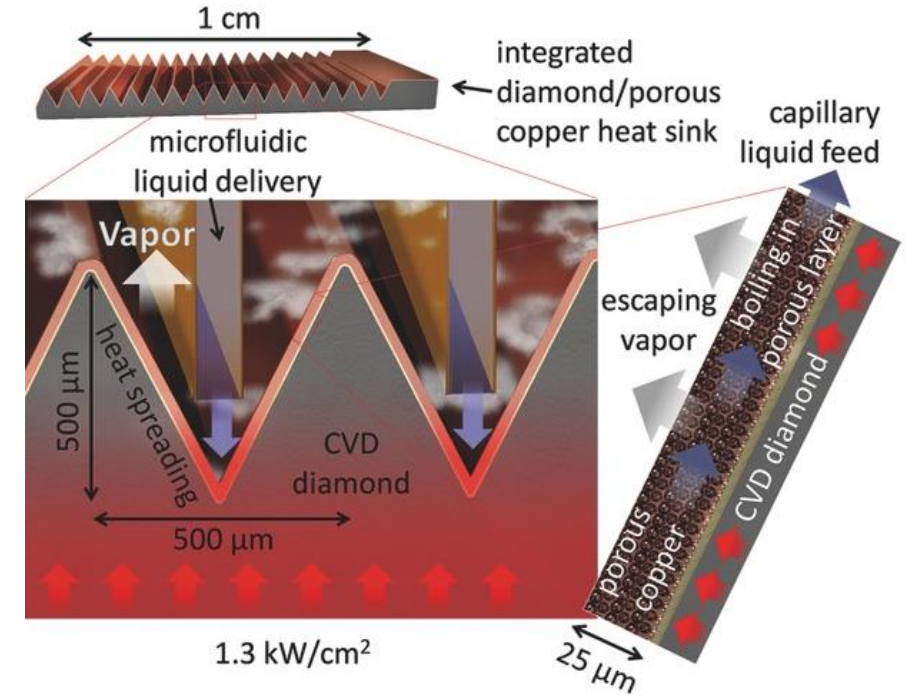

Two-phase cooling from microporous copper

Palko, *et al.*, *Advanced Functional Materials*, 2017

Credit: Zootalures and Offnfopt

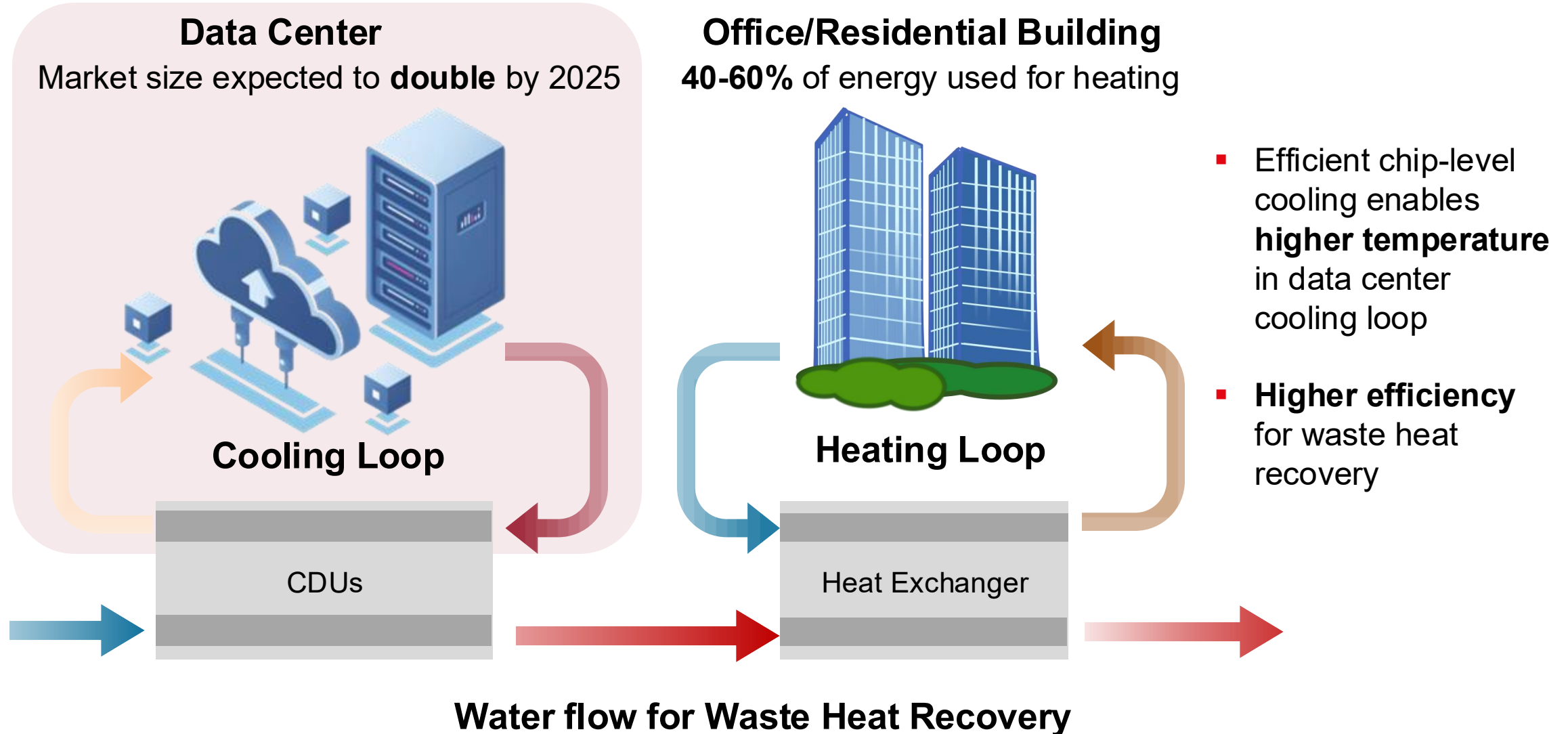



*REDUCING THE CARBON
FOOTPRINT OF DATA
CENTERS*

HEATING BITS



EPFL Sustainability Project

<https://heatingbits.epfl.ch>

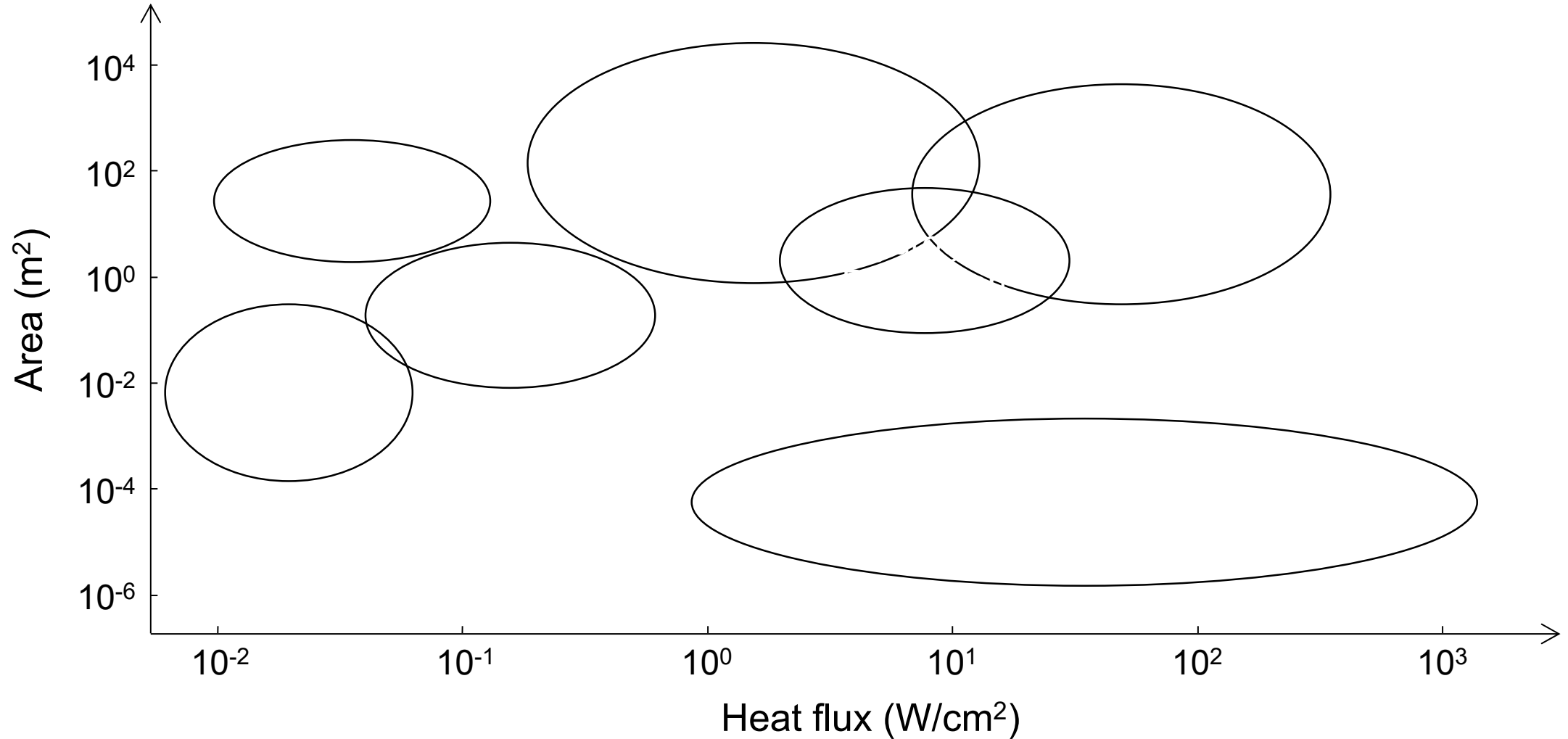

- 1. Capillarity and wetting
- 2. Evaporation physics
- 3. Pool boiling
- 4. Condensation
- 5. Flow boiling

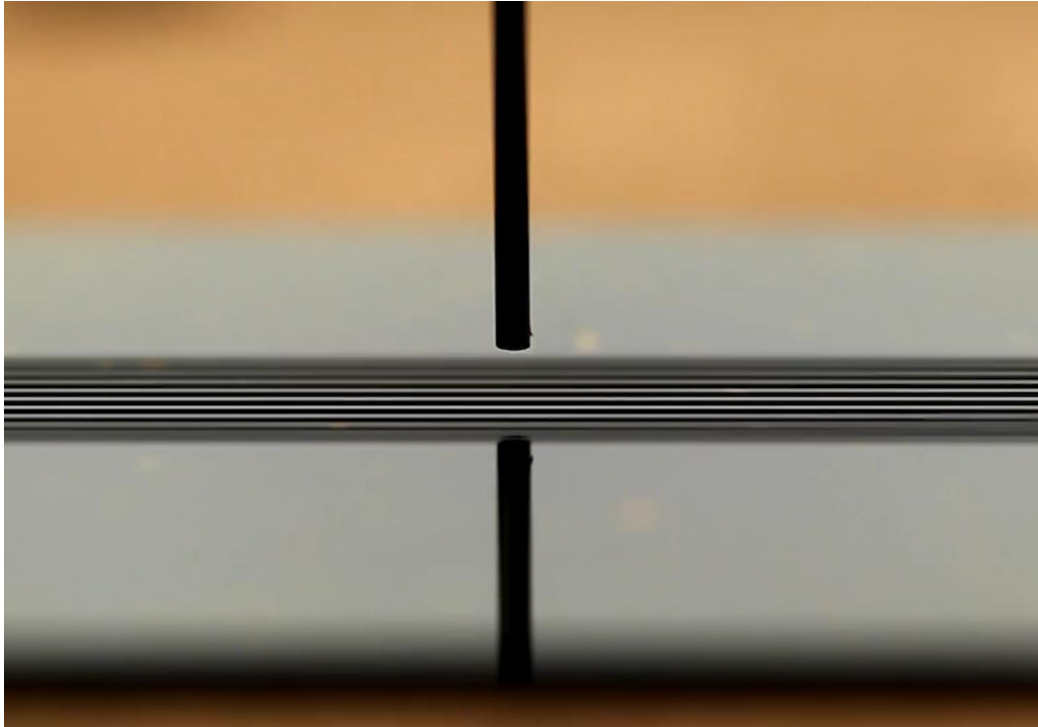

Capillary Wicking

Wilke *et al.*, *PNAS* 2021



Hydrophobicity

<http://davewirth.blogspot.com/2011/11/final-lotus-of-year.html>

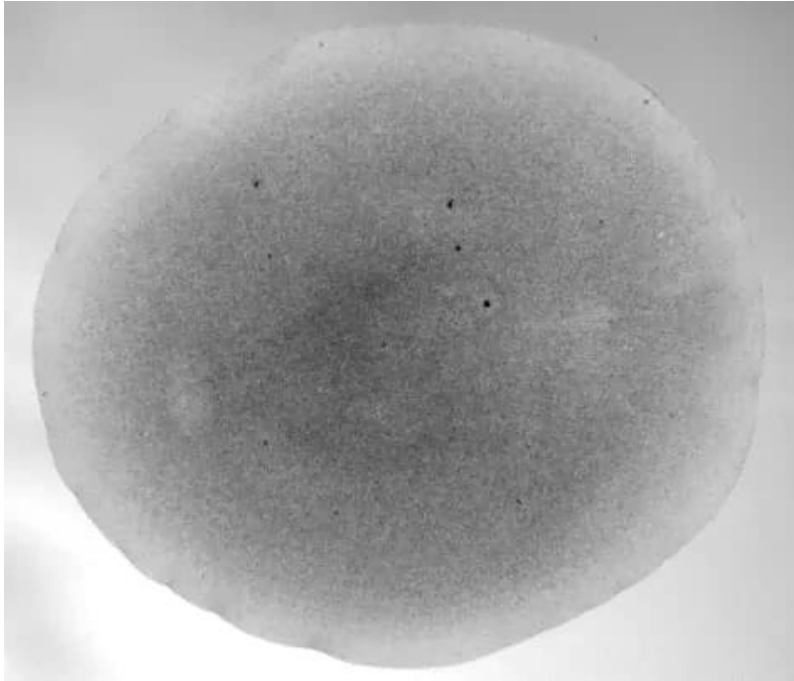

Yunker *et al.*, *Nature* (2011)

Molecular gas dynamics

Low total pressure

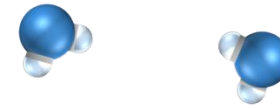

High total pressure

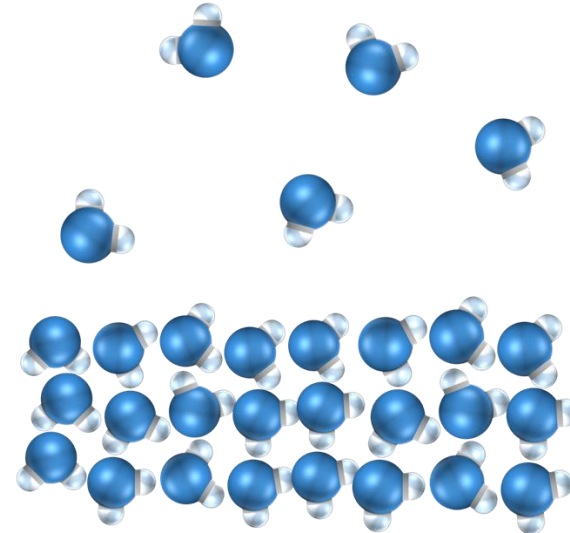

Lu *et al.*, *Nat. Comm.* 2019

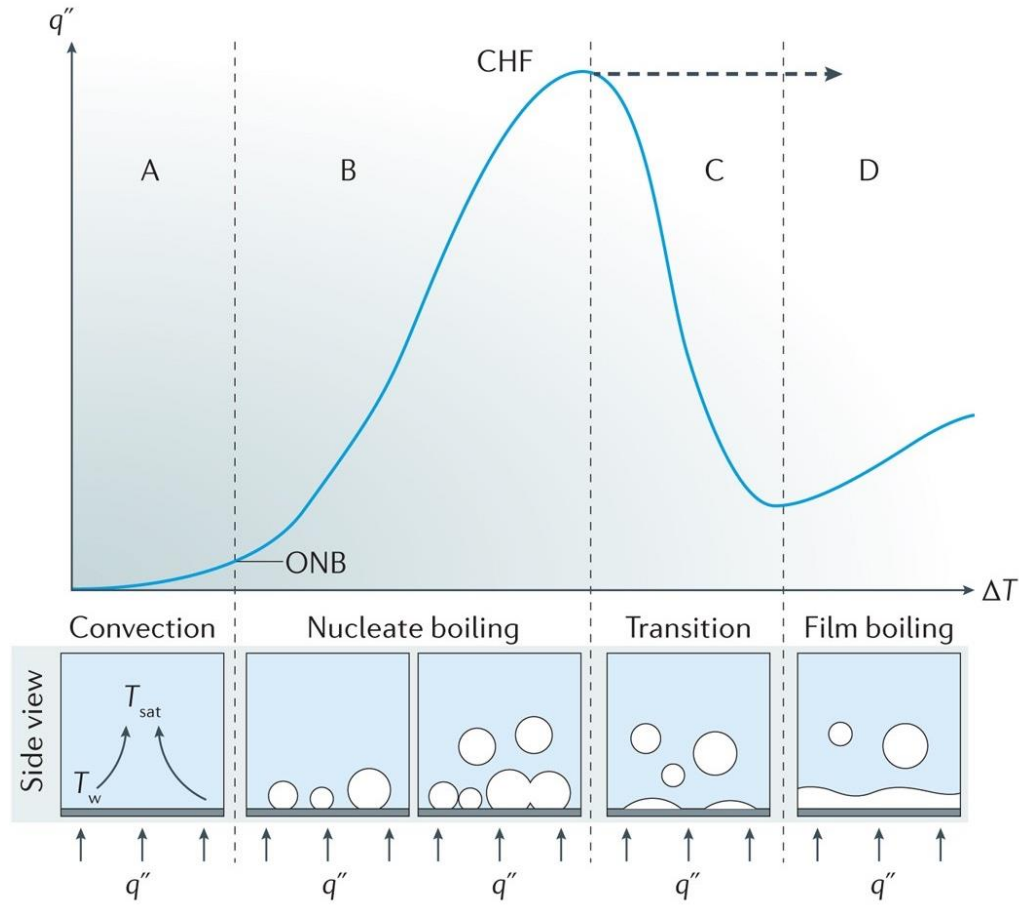

Cho et al., Nature Reviews Materials 2016

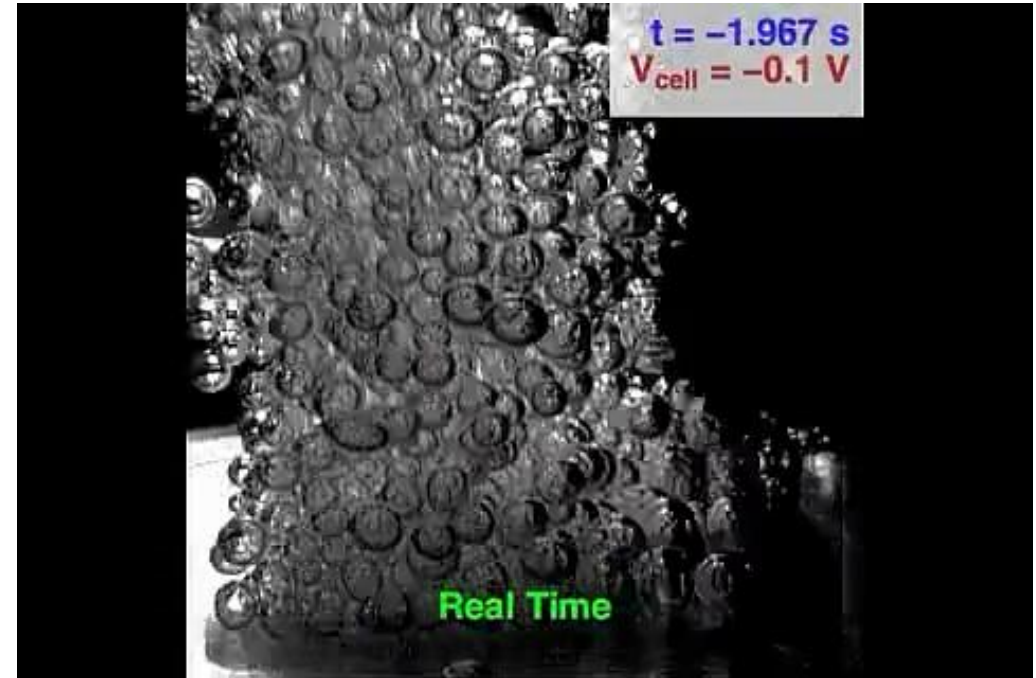

Cho et al., Nat. Comm (2016)

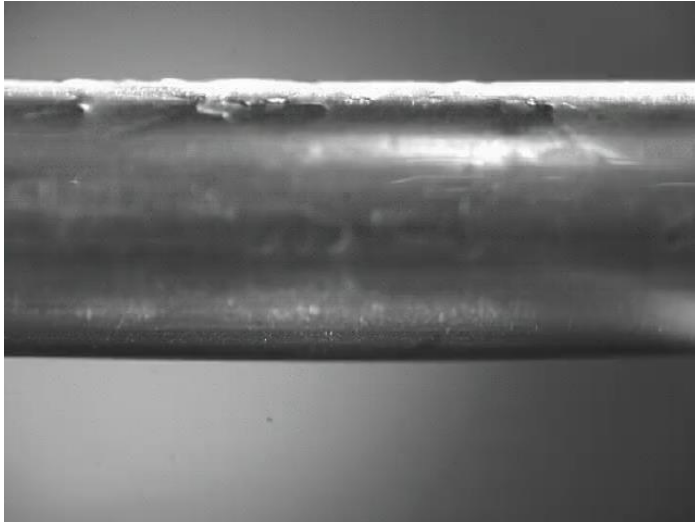

Filmwise condensation



Dropwise condensation

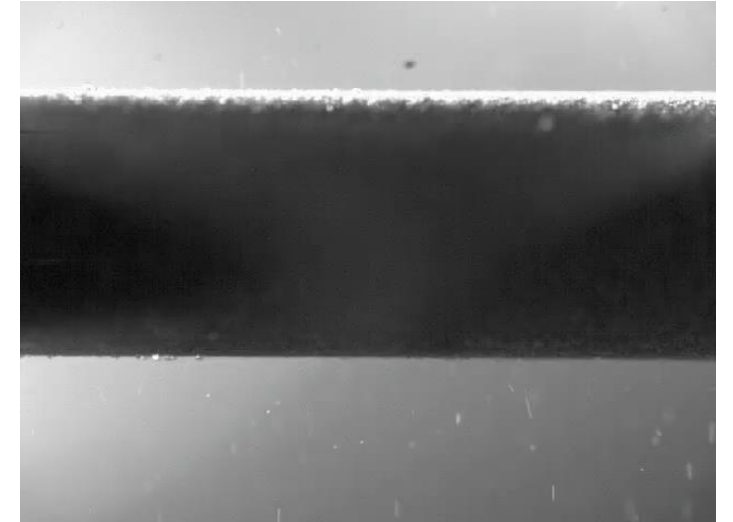

Jumping-droplet
condensation

Miljkovic *et al.*, *Nano Lett.* (2013)

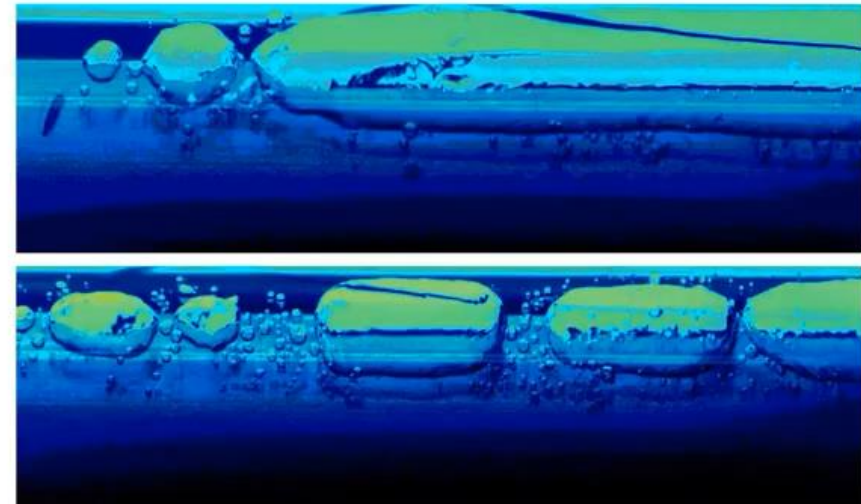
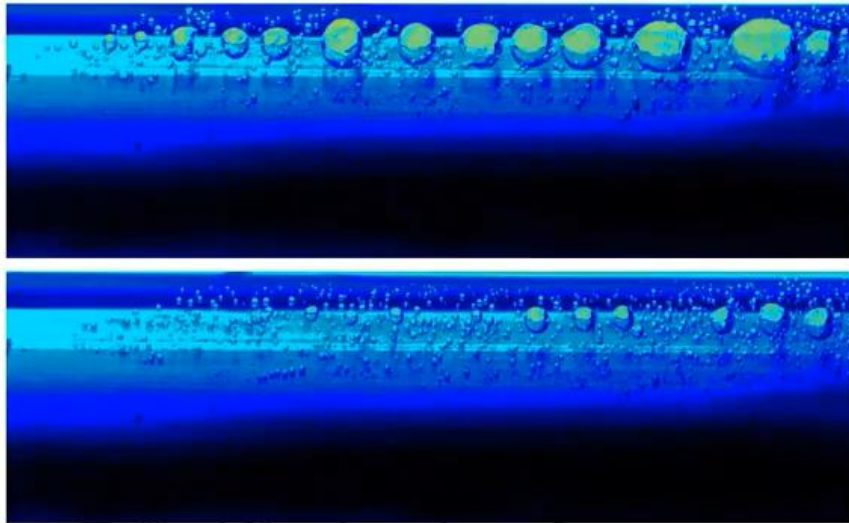

Different regimes in flow boiling (slowed down 50 times)

<https://www.youtube.com/shorts/HNcp7zDtwx8?feature=share>

At the End of the Semester, You Should Be Able to

- Explain **capillarity-driven phenomena** in the context of fluid films, bubbles, and droplets
- Analyze and quantify **heat and mass transfer** across liquid-gas interfaces
- Model phase change systems for **energy and water applications**

- Intended Learning Objectives
 - Explain the concept of **surface tension/surface energy**
 - Explain the concept of **Laplace pressure**
 - Apply **Young-Laplace equation** to liquid-gas interfaces

Reading materials: Carey Chapter 1.2, Chapter 2

Liquid-Vapor Interface (Molecular Perspective)

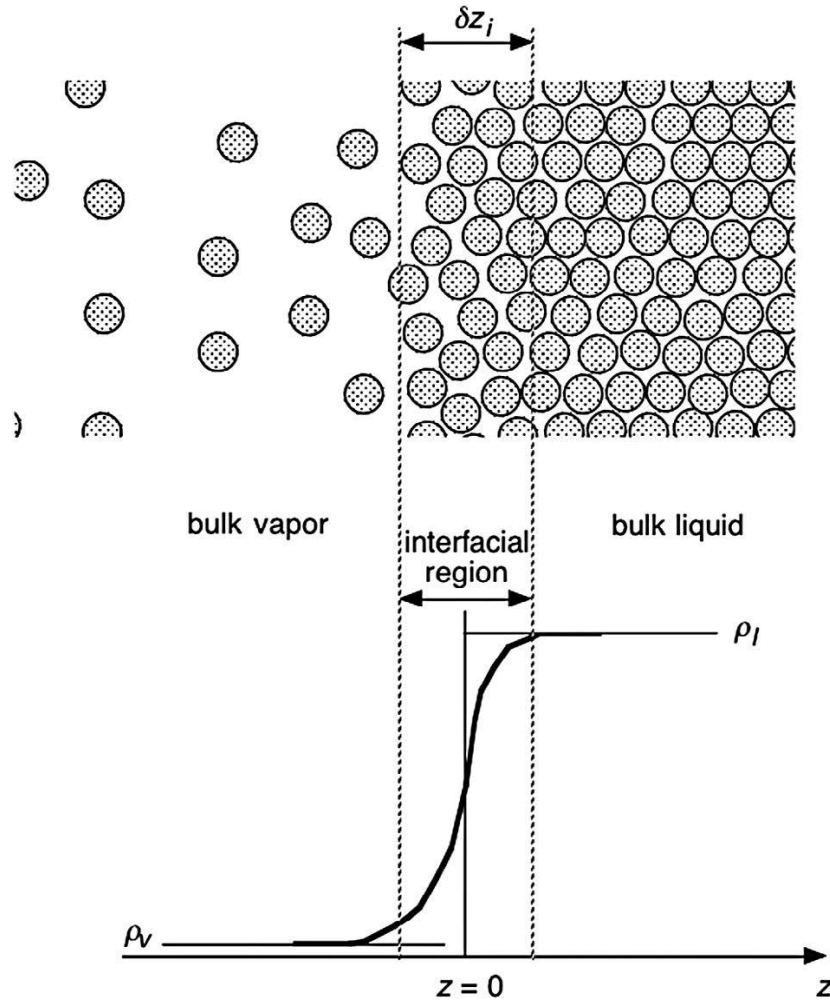

Density distribution near an interface with molecules **attracting** one another

Figure 1.3 in Carey

Surface Energy

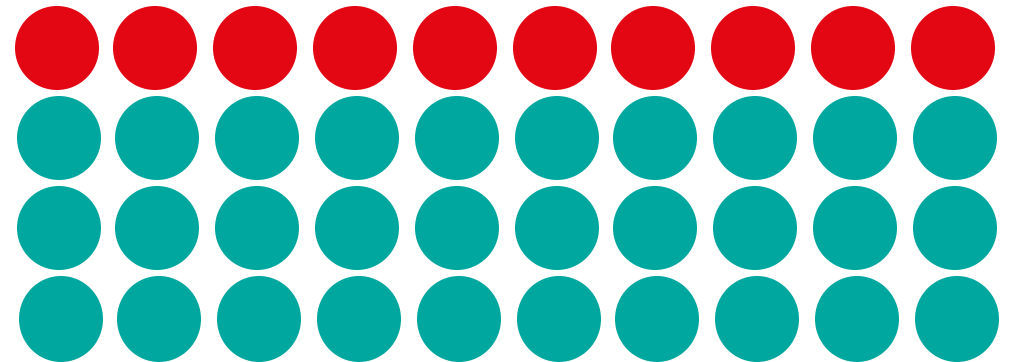
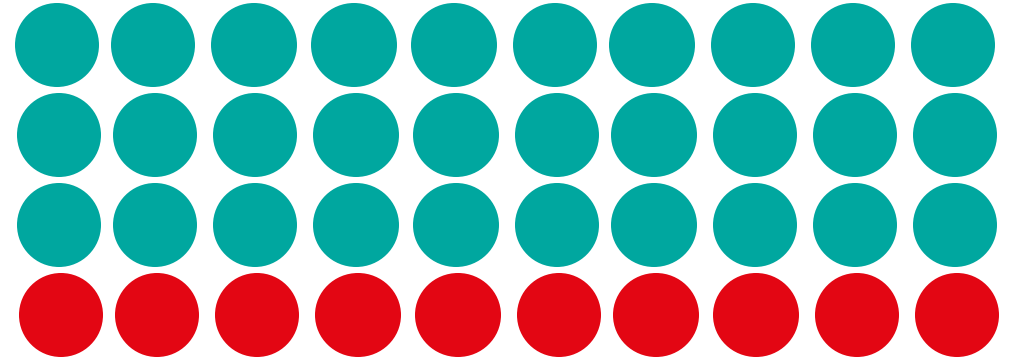
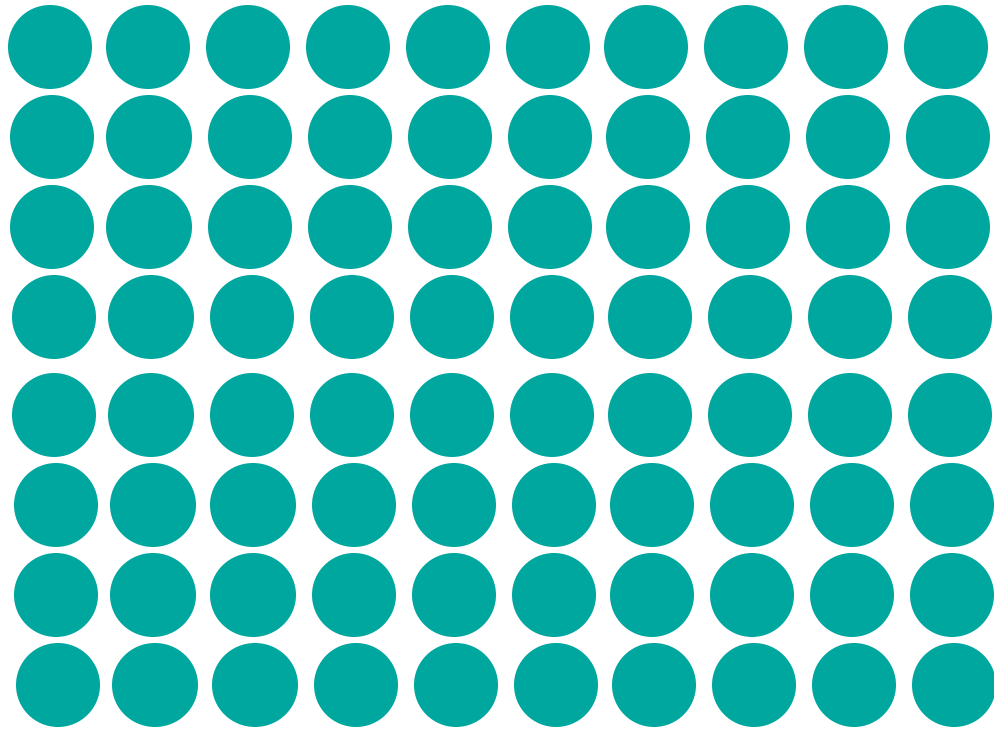

- Surface energy can be seen as the work that needs to be done to create a surface per unit area
- Surface energy depends on the intermolecular interaction

Values of Surface Tension for Various Liquids in Contact with Air or its Own Vapor at Saturation

Liquid	Temperature (°C)	Surface Tension (mN/m)
Silver (Ag)	1100	878
Mercury (Hg)	20	484
Hydrazine (N ₂ H ₄)	25	91.5
Water (H ₂ O)	20	72.8
Ethylene glycol (C ₂ H ₆ O ₂)	20	48.4
Ammonia (NH ₃)	-40	35.4
Carbon tetrachloride (CCl ₄)	20	27.0
<i>n</i> -Butanol (C ₄ H ₁₀ O)	20	24.6
Acetone (CH ₃ COCH ₃)	20	24.0
Ethanol (C ₂ H ₆ O)	20	22.8
Methanol (CH ₄ O)	20	22.6
R-113 (CCl ₂ FCClF ₂)	26.7	19.0
R-11 (CCl ₃ F)	26.7	18.0
R-12 (CCl ₂ F ₂)	17	9.4
R-134a (CF ₃ CH ₂ F)	18	9.0
Helium II (He _{II})	-271	0.32
Helium III (He _{III})	-271	0.069

Carey, Table 2.1

Surface Tension: Force per Length

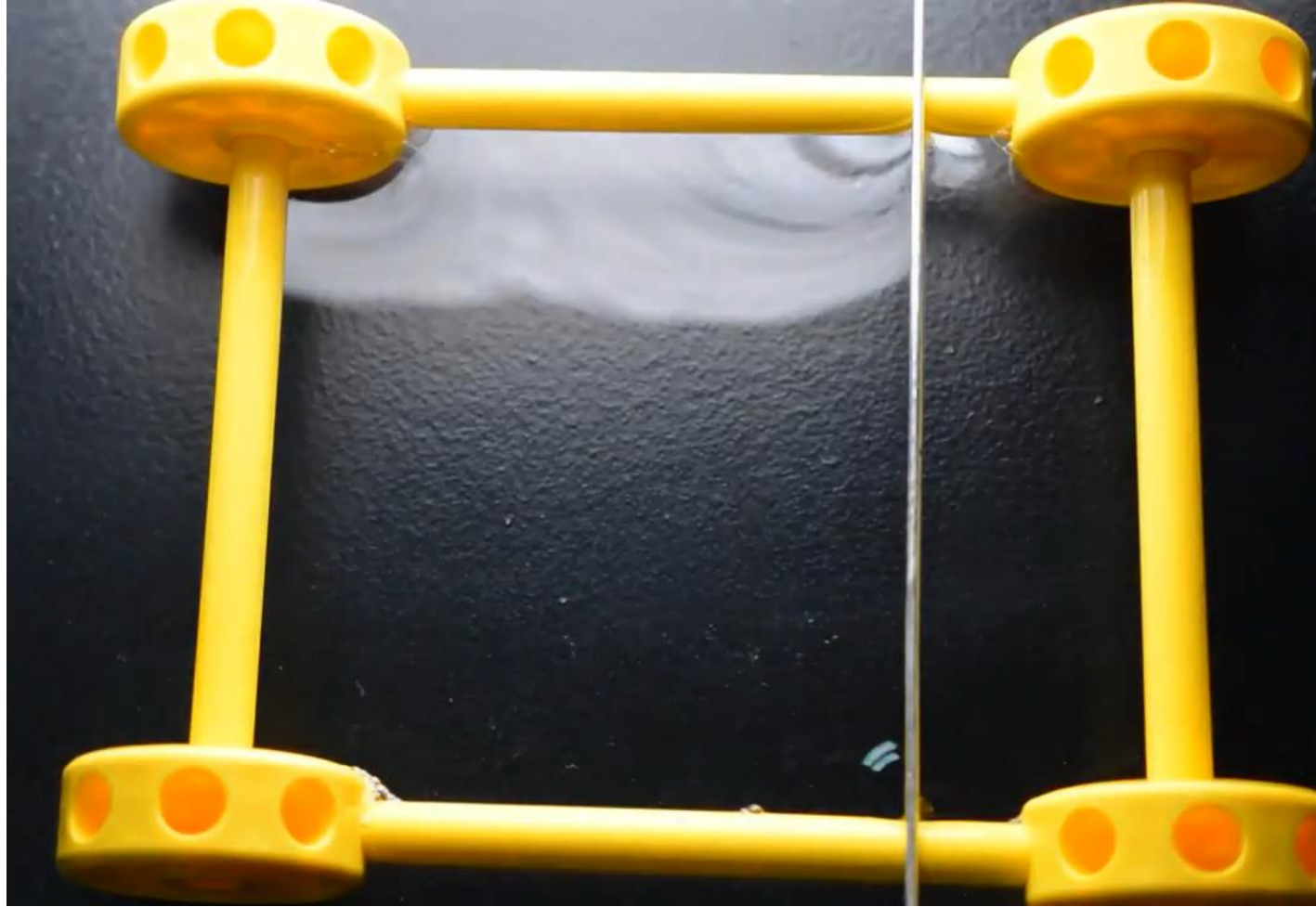

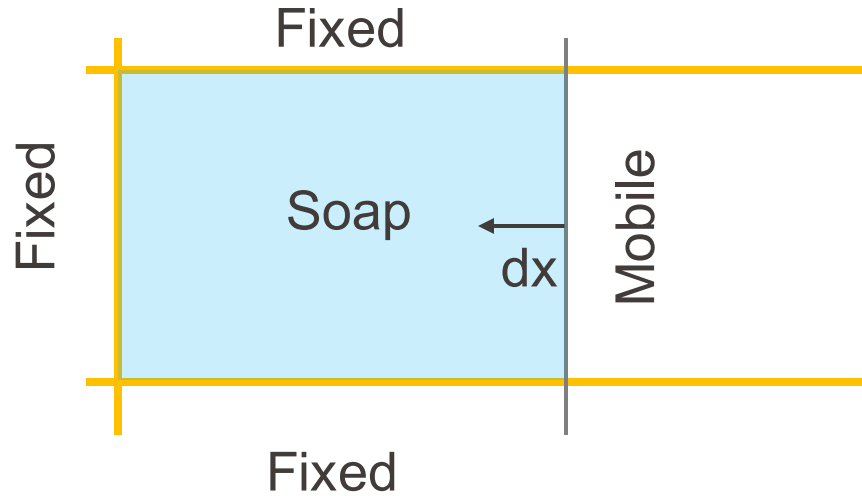

- The mobile rod moves in the direction of the arrow spontaneously because the system wants to minimize surface energy
- The surface exerts line forces on the rod:

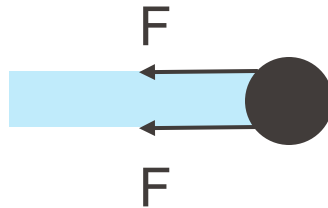

Air bubble in water

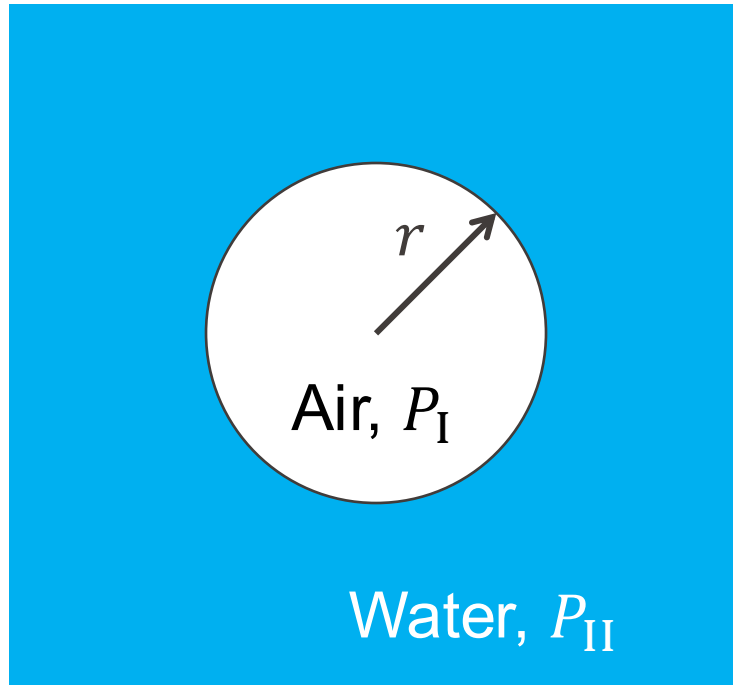

Derivation with the virtual work method

To join the session

Go to
echo360poll.eu

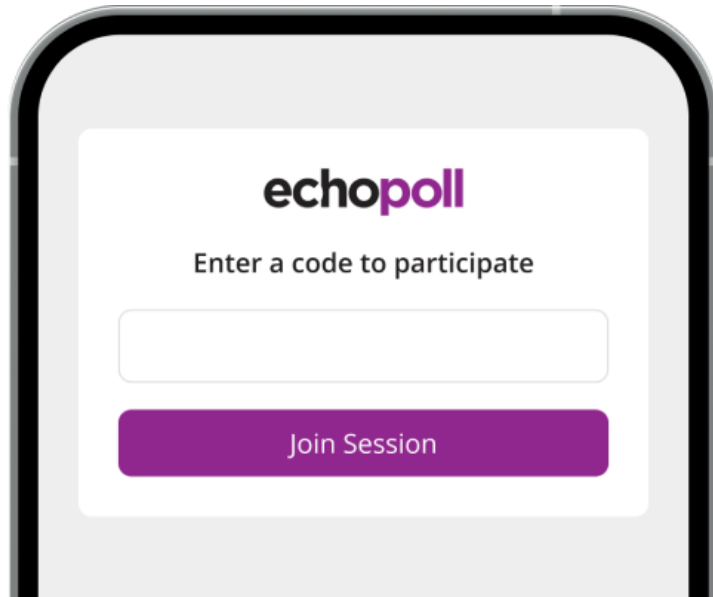

Enter Code
luepfl

Scan the QR code with
your device



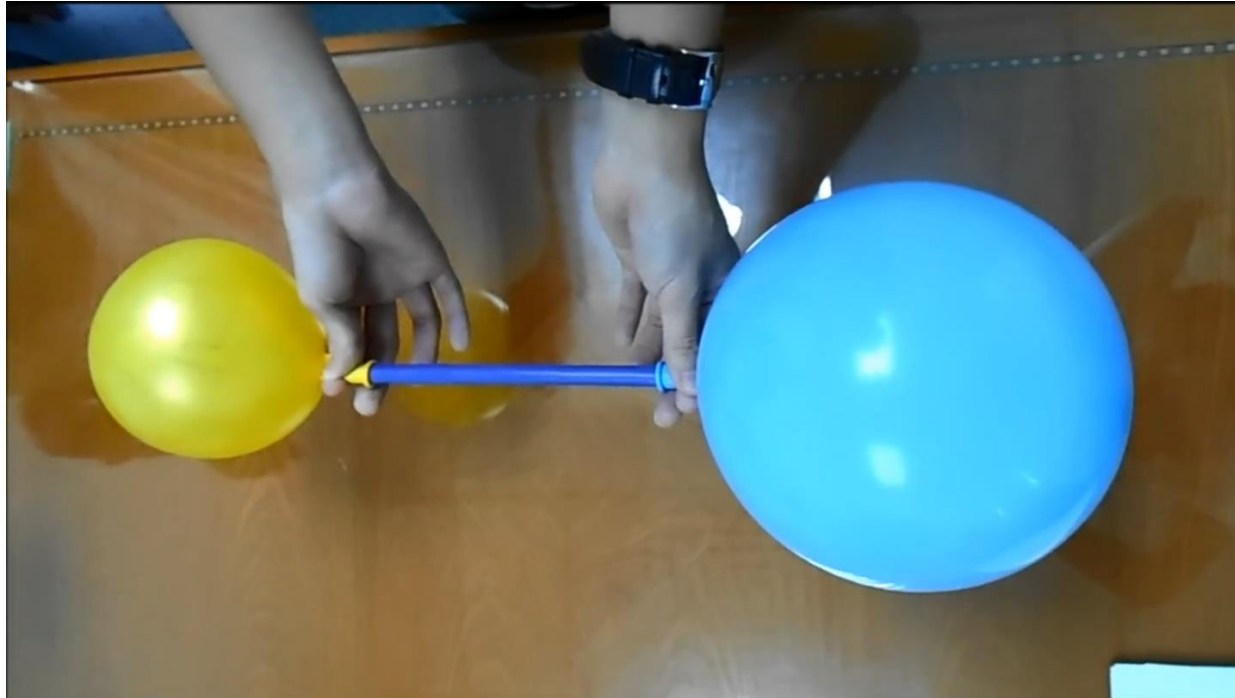

What will happen here?

- A. Two balloons become equal in size
- B. The yellow balloon becomes even smaller, and the blue balloon becomes even larger
- C. Both balloons become larger
- D. Both balloons become smaller

https://www.youtube.com/watch?v=_btWTwDVRj8&t=100s

Assuming balloon surfaces have the same surface tension

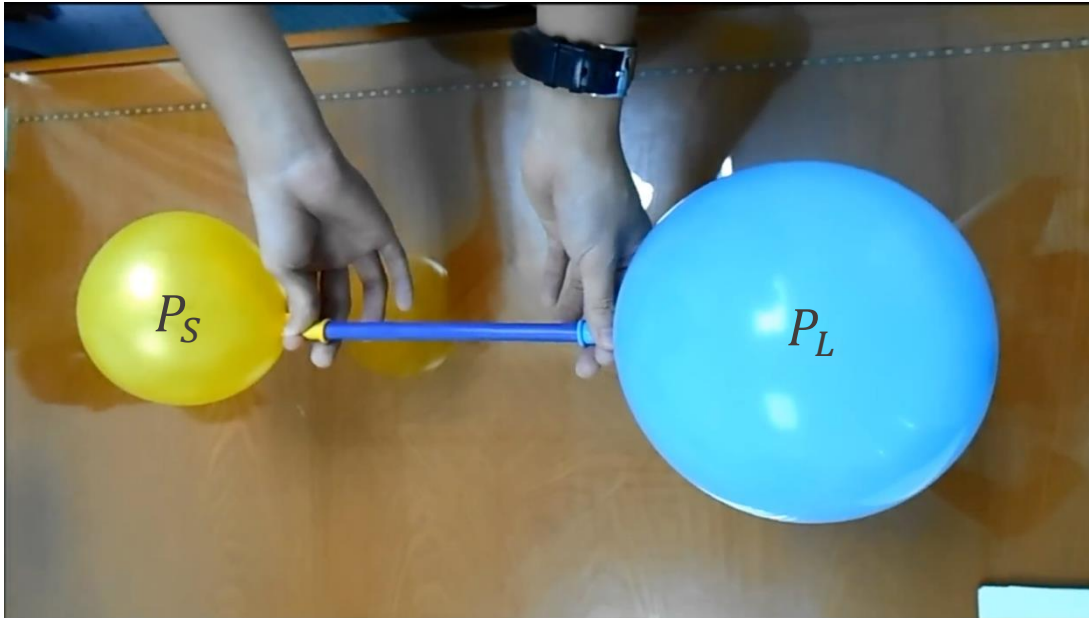

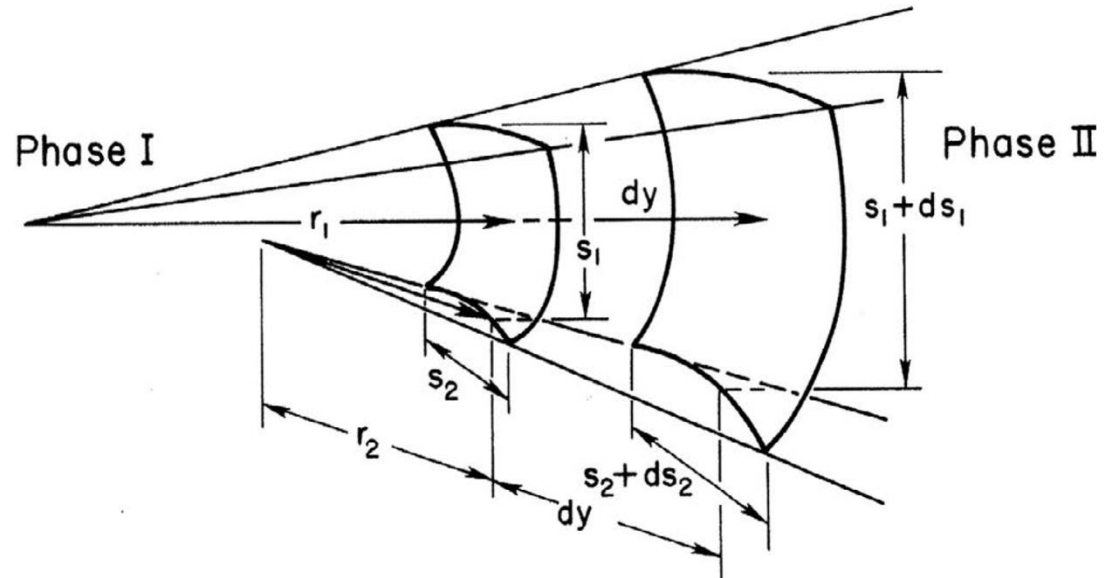

Derivation of Y-L Equation



- **Surface energy/surface tension:** the work that needs to be done to create a surface per unit area
- **Laplace pressure:** a result of surface tension and surface curvature
- **Young-Laplace equation:** quantify Laplace pressure as a function of surface tension and two principal radii