

# Additive manufacturing in the Weapon Industry

Introduction to additive manufacturing (ME - 413)

César Auzeau, Safouane Bouchelouche, Youssef Ziti, Alex Medina, Sergi Calls

# TABLE OF CONTENTS

<b>Introduction</b>	<b>01</b>	<b>04</b>	<b>Strategic and Operational Advantages in Battlefield</b>
<b>Techniques and Materials Used</b>	<b>02</b>	<b>05</b>	<b>Risks and Ethics of AM in the Weapon Industry</b>
<b>Practical Applications in Weapon Systems</b>	<b>03</b>	<b>06</b>	<b>Conclusion</b>

# Introduction

Impact of AM in different sectors

High-precision complex components

Adaptability



# Historical Context (Weapon Industry)

- Evolution in techniques

Subtractive  
&  
Replicative



# Historical Context (Weapon Industry)

- Additive Techniques

Early Use

Prototyping

Modern Day

Prototyping & much more





# 02

## Techniques and Materials Used

# Main techniques used in defence

- Defence relies on Additive Manufacturing for :

**Precision**

Dimensional accuracy



**Agility**

Adaptivity to new models

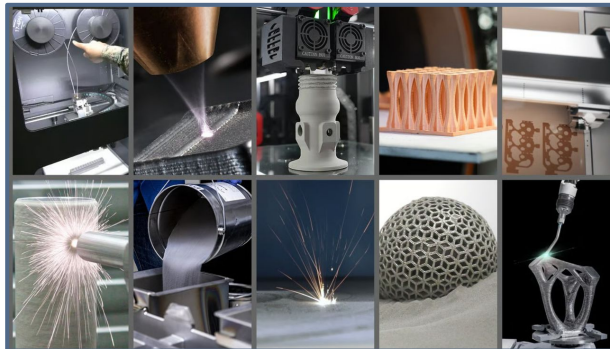

**Decentralised production**

On site manufacturing

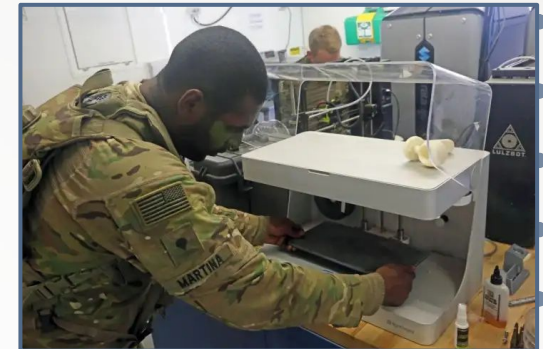

# Main techniques used in defence

- Three complementary AM technologies :

SLM  
**Selective laser melting**



DED  
**Directed energy deposition**

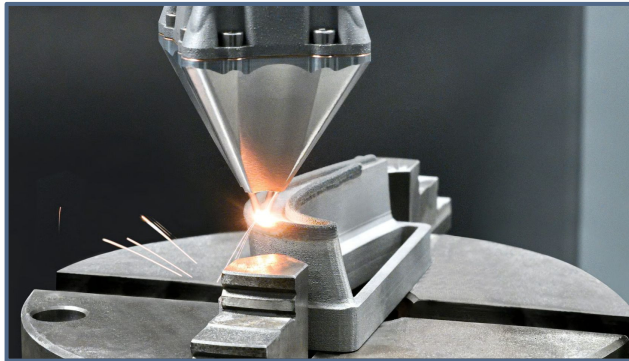

FDM  
**Fused deposition modelling**



# Selective Laser Melting

- Overview

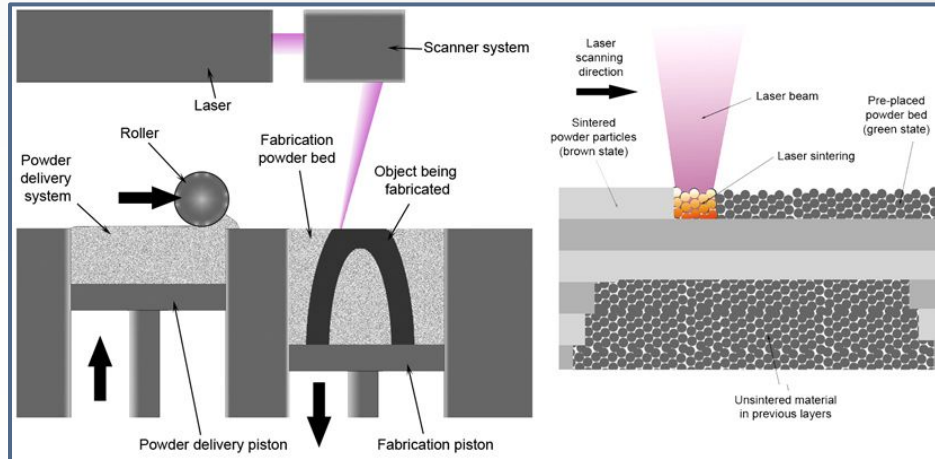

## Advantages

- **High precision** and design freedom (lattices, integrated parts).
- Excellent mechanical and thermal performance.

## Challenges

- **Residual stresses** → heat treatment required.
- Rough surface finish (5–15  $\mu\text{m Ra}$ ).
- Strict certification needed for safety-critical defence parts.

# Selective Laser Melting

- Defence applications :
  - Missile nozzles and drone propulsion components.
  - Thermal management parts with internal channels.
  - Lightweight topology-optimized frames and trigger housings.



GE LEAP fuel nozzle



Inconel 718 SLM turbine blade



Topology optimized bracket

# Directed Energy Deposition

- Overview

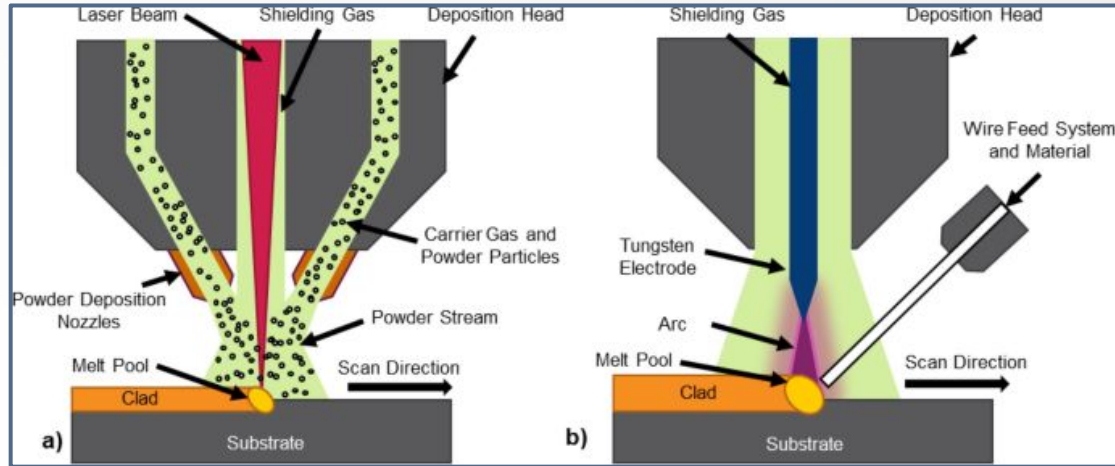

## Advantages

- **High deposition rate** (kg/h), cost-effective maintenance.
- Enables Military Logistics 4.0: production near front lines.

## Challenges

- **Lower accuracy** ( $\pm 0.3-0.5$  mm).
- Thermal distortion & need for in-situ monitoring.

# Directed Energy Deposition

- Defence applications :
  - Repair of gun barrels, armor, turbine blades, turbine housings.
  - Large structural builds and field-deployable workshops.
  - Wear-resistant coating / functionally graded layer on armor

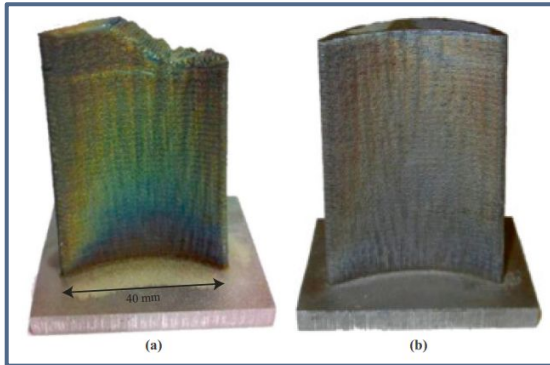

DED repaired turbine blade



Naval Group DED 3D printed propeller

# Fused Deposition Modelling

- Overview

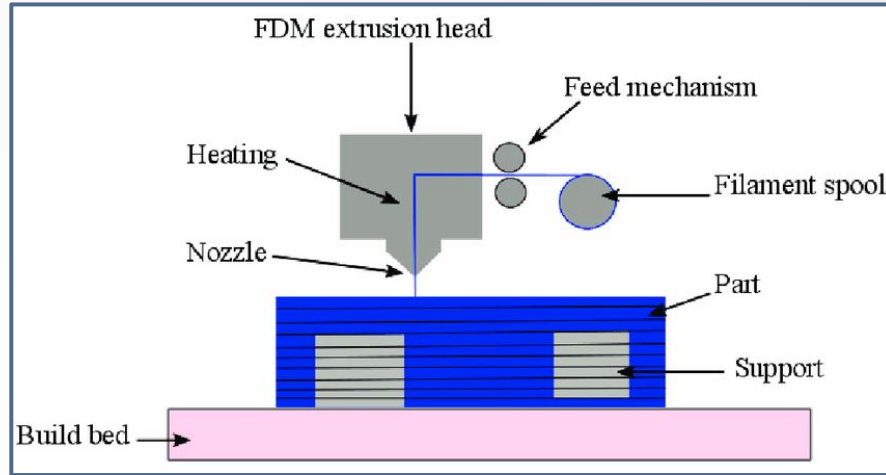

## Advantages

- **Low cost and accessibility**
- Rapid prototyping and customization
- Field adaptability

## Challenges

- **Limited mechanical performance**
- Anisotropic properties
- Surface finish and accuracy ( $\pm 0.1\text{--}0.3$  mm)

# Fused Deposition Modelling

- Defence applications :
  - Drone or UAV frames.
  - Jigs, fixtures, communication housings.
  - On-demand spare parts near the field.



FDM UAV drone



FDM AR-15 rifle stock



FDM electronics enclosure

# Metallic Materials

- Titanium Alloys

Weight-strength ratio

LPBF, DED

Ti-6242



High Temp. Performance

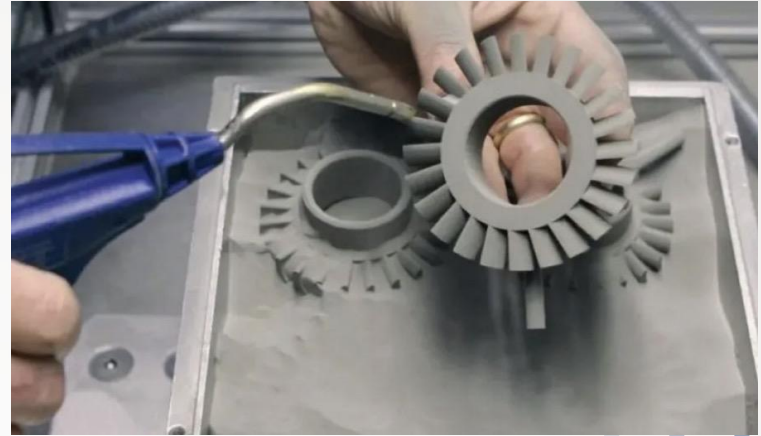

# Metallic Materials

- Aluminum Alloys

Less Strength

Lighter Weight

LPB, DED

2xxx, 6xxx, 7xxx Series



# Metallic Materials

- Stainless Steel

Corrosion Resistance

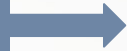

Coastal Equipment

More Economical

LPBF, DED

AISI-316L



# Metallic Materials

- Nickel-based Alloys

Superalloys

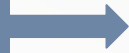

High Strength  
High Corrosion Resistance

Extreme Temperatures

LPBF, EPBF, DED

Inconel 718, 625



# Metallic Materials

- Cobalt-Chromium Alloys

Superalloys

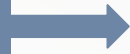

High Strength  
High Corrosion Resistance

Abrasion Resistance

LPBF, EPBF

MPI, F75



# Metallic Materials

- Cooper Alloys

Outstanding conductivity

Heat Exchangers

LPBF

CuCrZr

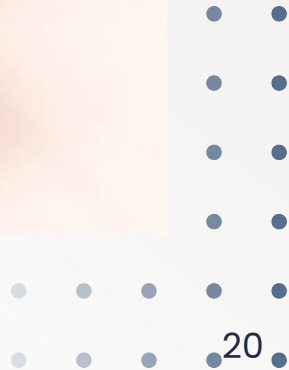

# Polymeric Materials

- Nylon 12 (PA12)

Mechanical Resistance

Prototyping / Non critical

SLS, Jet Fusion, FDM



# Polymeric Materials

- Polyetheretherketone: PEEK

High Specific Strength

Thermal Resistance

Lightweight

SLS, FDM

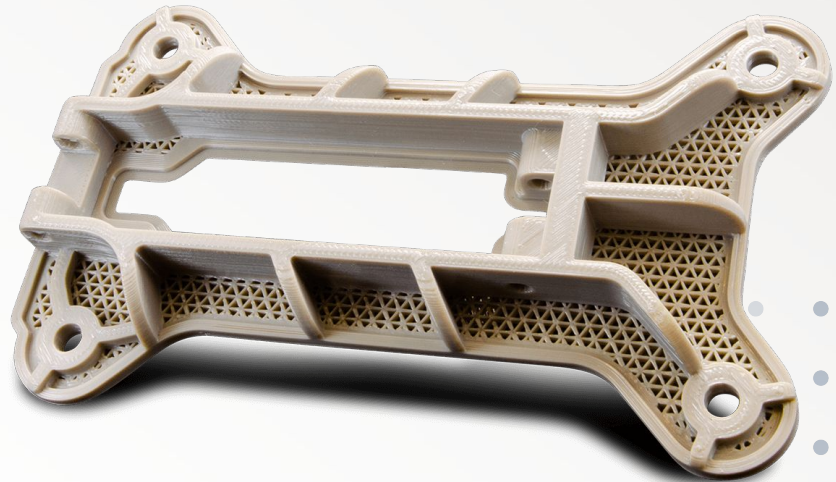

# Polymeric Materials

- Polietherimide: PEI

High Tensile Strength

Stiffness

Lightweight

SLS, FDM

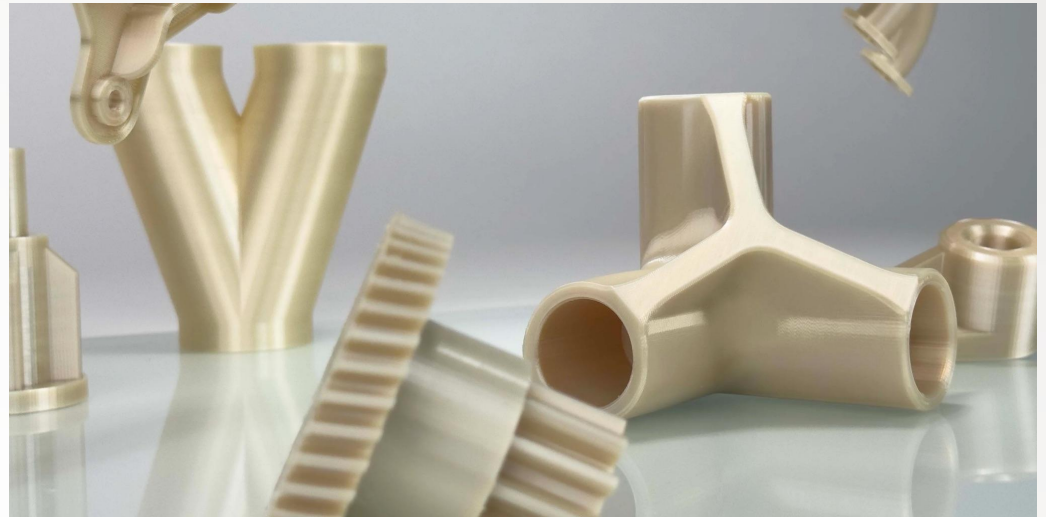

Electric Insulator

# Polymeric Materials

- Polyetherketoneketone: PEKK

Mechanical Strength

Stiffness

Load Bearing Capacity

SLS, FDM, Jet Fusion

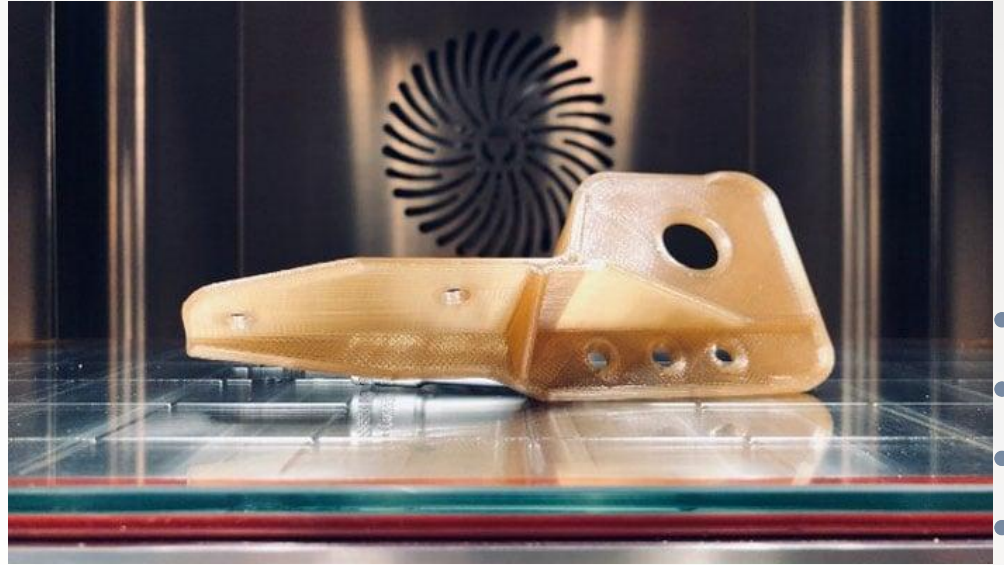

# Polymeric Materials

- Fiber-Reinforced Composites

Stronger than Polymers

Lighter than Metallic

FDM, SLS





03

## Practical Applications in Weapon Systems

# 3. Practical Applications in Weapon Systems

**3.1 Parts for Small Arms  
(Barrels, Triggers, Stocks)**



**3.2 Components for Drones,  
Missiles, and Armored Vehicles**

**3.3 On-Demand Spare Parts  
Production (Logistics 4.0)**



**3.4 Prototyping and Innovation  
Acceleration**

# 3.1 Parts for Small Arms

- Focus on subassemblies where geometry, ergonomics, or part consolidation deliver operational value.
- Key advantages:



Light- weight

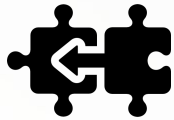

Part consolidation



Part customization



# 3.1 Parts for Small Arms

## Examples



Weapon Grip



Trigger Housings



Sight Mounts



# 3.1 Parts for Small Arms

## Risk Management



Strict certification and testing.

Phased approach:

1. Introduce AM in non-critical parts.
2. Validate materials and new parts under representative environments.
3. Gradually implement higher-criticality parts as standards and methods mature.



## 3.2 Components for Drones, Missiles, and Armored Vehicles

- AM is essential for lightweight components in **aerospace** and **defence**.
- Most prominent example: **Unmanned Aerial Systems** (UAS, drones) → every gram saved extends endurance and performance.
- It allows custom parts **without** needing **new tools or molds**.
- Multiple machined parts can be printed as **one optimised structure**

Lower Weight

Faster Assembly

Fewer Failure Points





**French Navy** - Metallic propeller (2.5 m diameter)



## Illustrative real-world data

**General Electric Aerospace** - Aircraft Fuel nozzle tip

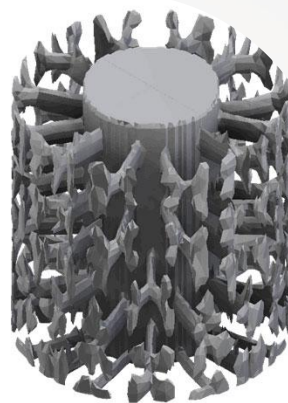
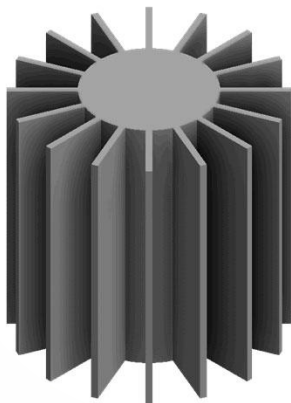

**U.S. Army** - Heat exchanger prototype for aircraft engine

### 3.3 On-Demand Spare Parts Production (Logistics 4.0)

- AM transforms traditional, centralised supply chains into distributed, digital and responsive networks (Logistics 4.0).
- What is Logistics 4.0?
  - Extension of Industry 4.0 concepts to logistics (AI, IoT, AM...)
  - Focuses on digital integration between design, production, and supply chain.
- Additive Manufacturing enables on-demand, local production.
- Replaces physical inventories with digital libraries and data workflows.



# 3.3 On-Demand Spare Parts Production (Logistics 4.0)

Conventional model



Dependent on warehouses, long transport routes, and complex inventories

- Delays and obsolescence.

AM model



Parts produced near the point of need

Enables **on-demand production**, reducing storage requirements and downtime.



## 3.3 On-Demand Spare Parts Production (Logistics 4.0)

### Digital Supply Chains – Key Consequences

- Greater exposure to cyber risks.
- Need for real-time coordination.
- Lower transport and storage costs.
- On-demand production.
- Local adaptation to environment needs.



# 3.4 Prototyping and Innovation Acceleration

- Fast and iterative design process.
- Data-driven optimisation and testing.
- Reduces **cost**, **waste**, and **development time**.

## PROTOTYPING

Fast

Iterative

Data-driven



Cost

Waste

Time

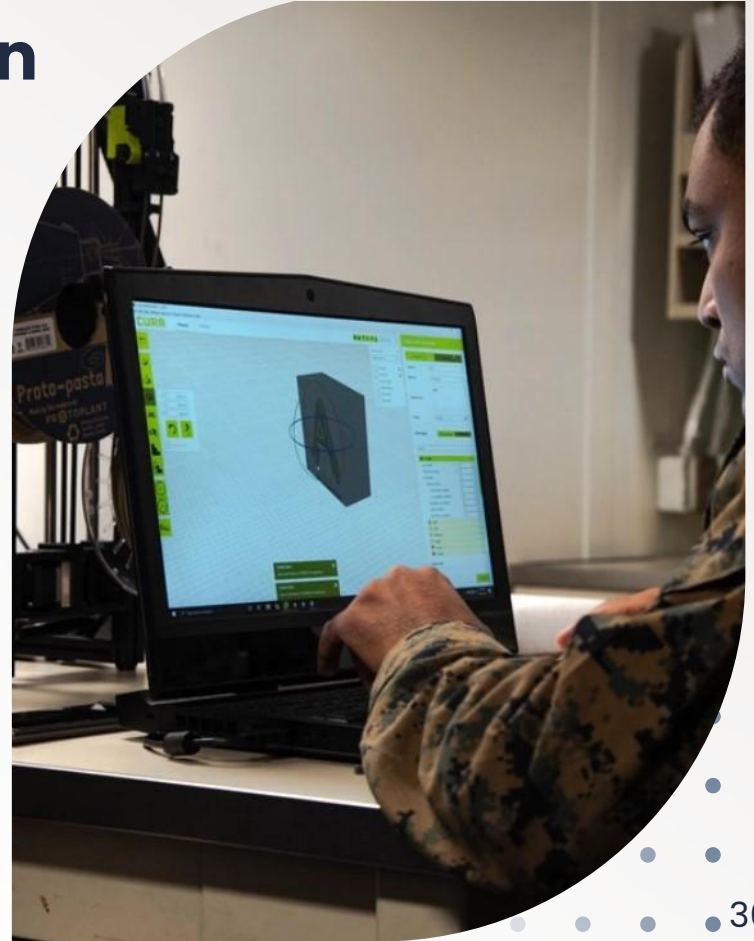



# 04



## Strategic and Operational Advantages in Battlefield

# Ukraine War revealed the potential of AM in weapon industry



# Why FPV Drones ?

- Initially designed for **racing and cinematography**
- Cheap, lightweight, easy to modify ( $\approx$  300 – 700 USD/unit)
- Converted into **loitering munitions** with onboard cameras
- **3D printing enables structural redesign:** frames, mounts, payload supports
- Combines **first-person-view piloting** and **real-time precision strikes**



# Tanks targeting comparison

## FPV Drone

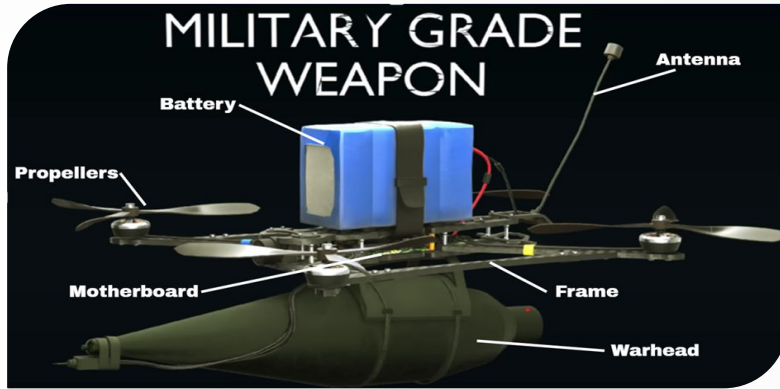

- Operator safer
- Simple design
- Simple Assembly
- Quick to produce locally
- Highly maneuverable
- Cheap (~1000 \$ per drone)









## Javelin Missile









- Operator at high risk
- Complex logistics
- Rely on foreign imports
- High cost (~80 k\$ and ~250 k\$ per missile)

# Main manufacturers in Ukraine



 <p><b>10-INCH FPV DRONE (ANALOG)</b></p>	 <p><b>ANTI-AIR FPV DRONE (DIGITAL)</b></p>	 <p><b>FPV BOMBER DRONE</b></p>
 <p><b>HORNET QUEEN – 17-INCH FPV DRONE</b></p>	 <p><b>HORNET QUEEN WITH GSNN SECURE COMMUNICATION MODULE</b></p>	 <p><b>DIGITAL GROUND CONTROL STATIONS</b></p>

 <p><b>FPV DRONES UAV KOLIBRI 7"</b></p> <p><b>12 KM</b> max. combat radius</p> <p><b>15 MIN</b> max. flight duration</p> <p><b>1.5 KG</b> max. payload</p> <p><a href="#">MORE DETAILS</a></p>	 <p><b>FPV DRONES UAV KOLIBRI 8"</b></p> <p><b>18 KM</b> max. combat radius</p> <p><b>19 MIN</b> max. flight duration</p> <p><b>1.5 KG</b> max. payload</p> <p><a href="#">MORE DETAILS</a></p>	 <p><b>FPV DRONES UAV KOLIBRI 10"</b></p> <p><b>25 KM</b> max. combat radius</p> <p><b>27 MIN</b> max. flight duration</p> <p><b>2.4 KG</b> max. payload</p> <p><a href="#">MORE DETAILS</a></p>
 <p><b>FPV DRONES UAV KOLIBRI 13"</b></p> <p><b>20+ KM</b> combat radius</p> <p><b>30 MIN</b> flight duration</p> <p><b>1.5+ KG</b> payload</p> <p><a href="#">MORE DETAILS</a></p>	 <p><b>OPTIC FIBER FPV KOLIBRI 10-O [OPTIC FIBER]</b></p> <p><b>10 KM</b> combat radius</p> <p><b>UP TO 15 MIN</b> flight duration</p> <p><b>UP TO 1.5 KG</b> payload</p> <p><a href="#">MORE DETAILS</a></p>	 <p><b>OPTIC FIBER FPV KOLIBRI 13-O [OPTIC FIBER]</b></p> <p><b>15 KM</b> combat radius</p> <p><b>UP TO 17 MIN</b> flight duration</p> <p><b>UP TO 3.0 KG</b> payload</p> <p><a href="#">MORE DETAILS</a></p>

# Manufacturing process

- Starts with a **3D design on CAD software** (body, arms, battery holder, cover)
- Each part is **printed separately** → easy repair & fast reproduction
- **Rapid iteration**: designs can be updated and reprinted within hours
- Uses **“print–test–adjust”** cycle → continuous improvement under pressure
- Production in **“printer farms”**: rooms full of small, affordable 3D printers
- Common models: **Bambu Lab, Elegoo** – reliable and easy to maintain
- **Distributed production** ensures continuity even if one site is down

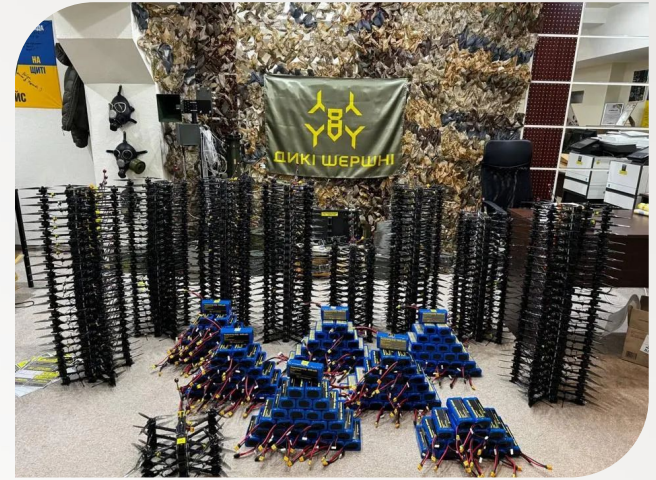

# Example of a “printer farm”



# Assembly workshop

- **Technicians work in parallel** on benches with pre-printed frames and electronics
- Each station handles a **specific sub-task** (motor mount, electronics, wiring, etc.)
- **Components installed:** motors, ESCs, flight controller, LiPo battery, FPV/thermal camera
- **Calibration station:** loads firmware, calibrates sensors, checks motor directions
- **Final tests:** vibration, video latency, short hover & speed tests
- After inspection, the drone is **declared mission-ready**



# New War Tactics

- The Ukrainian war revealed the **rise of low-cost FPV drones** in modern combat.
- FPV drones can destroy **military equipment worth millions** with **only a few hundred dollars** in parts.
- This marks a **new balance between cost and destructive power**.
- Example: **“Spider’s Web” operation** (SBU, June 1st, 2025) — **117 FPVs** struck **Russian airbases deep inside Russia**.



# Spider Web Operation



# Cheap Drones, Priceless Targets

- This event shows the **huge economic gap** between **attack tools and targets**.
- Each **FPV drone** costs **\$1,000**.
- In contrast, a **Russian strategic bomber** (Tu-95 or Tu-22) is worth **\$100–\$200 million**.
- An **A-50 AWACS aircraft** can exceed **\$300 million**.
- **\$7 billion** of losses for Russia (and also **the reputation**)

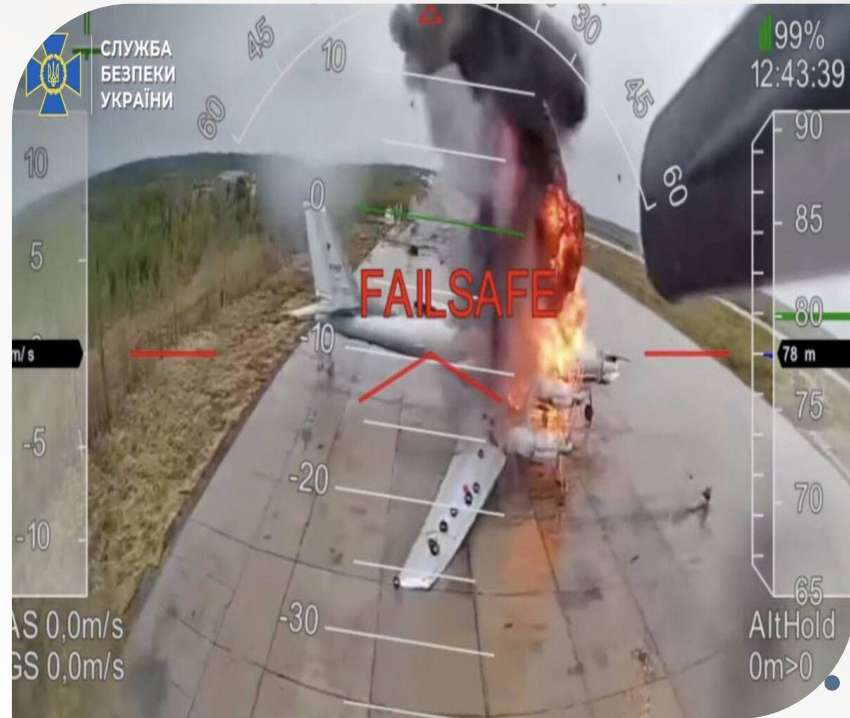



**05**

## **Risks and Ethics of AM in the Weapon Industry**

# 5. Risks and Ethics of AM in the Weapon Industry

**5.1 The Industrial Challenge : Trust the process**



**5.2 The Illicit Frontier: The Rise of the Ghost Gun**

**5.3 The Societal Impact: Regulation and Security Erosion**



**5.4 Responsibility in a Digital Arsenal**

# 5.1 The Industrial Challenge : Trust the process

## Innovation vs. Control

- **Industry's Crisis:** How to certify a process made layer by layer?
- **Society's Crisis:** How to regulate what can be made anywhere, by anyone?
- The same flexibility that empowers innovation also enables misuse.



# 5.1 The Industrial Challenge : Trust the process

## Why Certifying AM Parts is So Difficult ?

- In traditional manufacturing: material properties are known before shaping.
- In AM: they're created during printing.
- Microstructure depends on: laser power, scan path, powder quality, temperature.
- Result: unpredictable defects, porosity, or warping.

# 5.1 The Industrial Challenge : Trust the process

## Same Design, Different Strengths

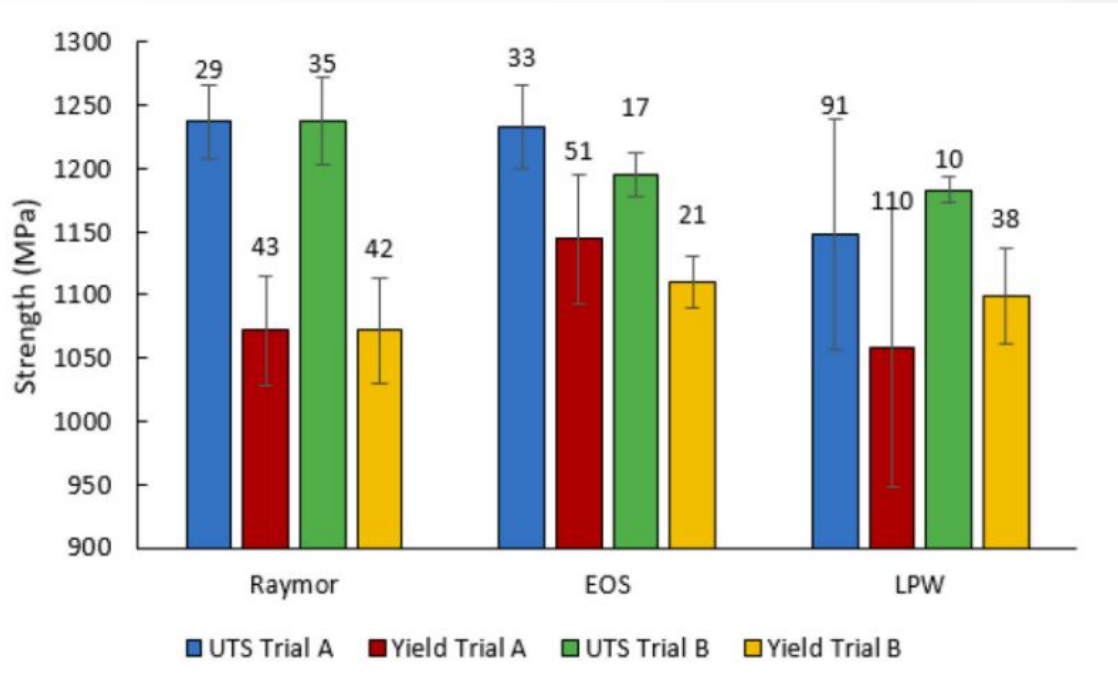

Variation in tensile properties of Ti-6Al-4V (Ti64) specimens produced using powders from different suppliers (Raymor, EOS, LPW).

# 5.1 The Industrial Challenge : Trust the process

## Same Design, Different Strengths

- Case Study: Ti-6Al-4V (Aerospace-grade titanium)
- Same printer and design, different powder suppliers.
- Strength variation >150 MPa; yield variation  $\approx$ 100 MPa.
- Lesson: You certify the entire process chain, not just geometry.

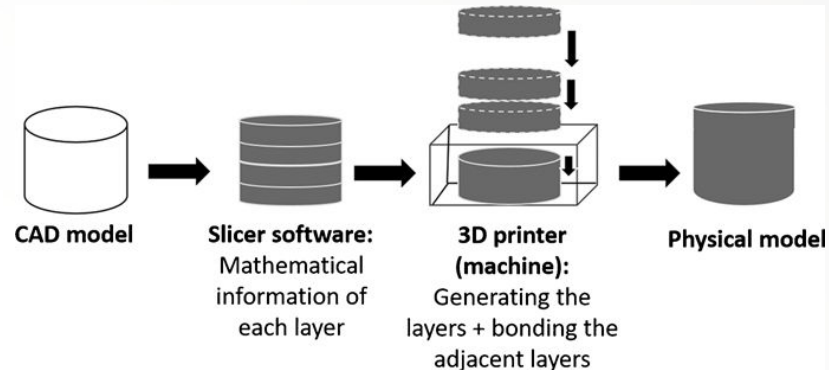

# 5.1 The Industrial Challenge : Trust the process

## When the File Becomes the Weapon

- AM's blueprint = digital file.
- Case: "dr0wned" experiment, altered CAD propeller file caused drone crash.
- Defect invisible to visual inspection.
- New risk: invisible sabotage at the code level.

# 5.1 The Industrial Challenge : Trust the process

## When the File Becomes the Weapon

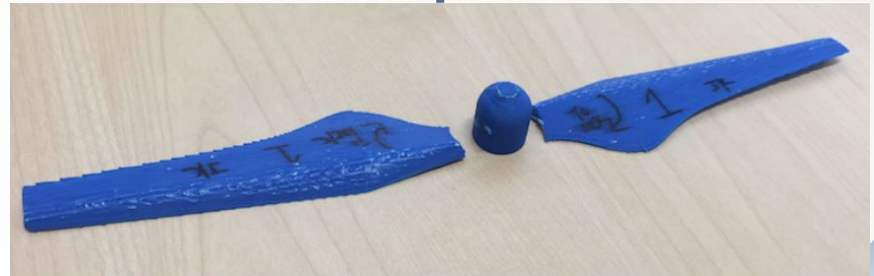
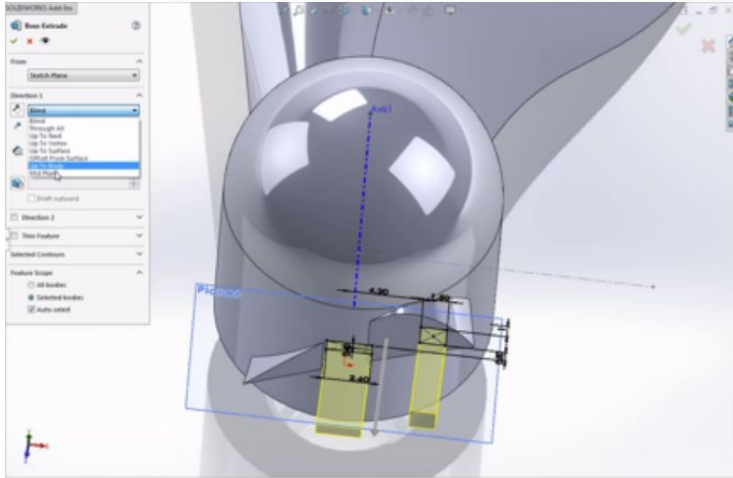

# 5.2 The Illicit Frontier: The Rise of the Ghost Gun

## The FGC-9: A Weapon Without a Factory



## 5.2 The Illicit Frontier: The Rise of the Ghost Gun

### FGC-9: A Weapon Without a Factory

- The FGC-9 (“F\*\*\* Gun Control 9”) → designed for home manufacturing.
- 3D-printed receiver + simple steel tubing barrel.
- Free blueprints + tutorials online.
- Represents open-source weaponization.



## 5.2 The Illicit Frontier: The Rise of the Ghost Gun From Serial Numbers to STL Files

- Traditional control: factories, import routes, serial numbers.
- New reality: digital files, open-source forums, and encrypted sharing.
- Problems: Undetectable, Untraceable (no serials), Unregulated
- Regulators struggle to catch up.



## 5.3 The Societal Impact: Regulation and Security Erosion

### How Additive Manufacturing Outruns the Law ?

- Global treaties (Wassenaar, ITAR) depend on centralized manufacturing.
- AM breaks this model, weapons can be printed anywhere.
- Law enforcement faces new problems:
  - Impossible to track files or detect production.
  - No clear jurisdiction for digital crimes.
- National borders mean little when the threat is digital.

## 5.3 The Societal Impact: Regulation and Security Erosion

### The Security Erosion

- The State's authority relies on controlling violence → now anyone can produce arms.
- Decentralized groups or individuals can bypass surveillance.
- “Garage militarization” phenomenon: local weapon production for extremist or criminal use.
- Potential scenario: drone warfare + printed weapons = asymmetric threat.

# 5.3 The Societal Impact: Regulation and Security Erosion

## Regulating Innovation Without Stifling It

- Governments face an ethical-legal paradox:
  - Restrict file sharing → limit free speech and innovation.
  - Allow open exchange → risk proliferation.
- Need for new frameworks:
  - Controlled digital distribution (verified users, encrypted logs).
  - International cooperation against illicit AM markets.
- The debate mirrors the internet's birth: open access vs. control.



# 5.4 The Ethical Crossroads: Responsibility in a Digital Arsenal

## Securing the Promise, Containing the Peril

- Ethical dilemmas:
  - Open knowledge vs. security.
  - Empowerment vs. accountability.
- Who's responsible?
  - The designer? The platform? The printer manufacturer?
- Future paths: Blockchain traceability for design files; International AM weapon regulation frameworks; Ethics education for engineers & makers.



# CONCLUSION

# QUESTIONS