

The background image is a composite of two scenes. The left side shows a traditional wooden windmill with a lattice structure, set against a sky with soft, pinkish clouds. The right side shows a large industrial cooling tower, also with a lattice structure, set against a similar sky. A paved path leads from the foreground towards the cooling tower. The entire image has a semi-transparent red overlay on the right side where the title is located.

ME-251: Thermodynamics and energetics I

Zhengmao Lu
Energy Transport Advances
Laboratory (ETA-LAB)
EPFL Mechanical Engineering

2025 Fall Semester

Photo Credit: Trougnouf

- First half: Zhengmao Lu (zhengmao.lu@epfl.ch)
- Second half: Sophia Haussener (sophia.haussener@epfl.ch)
- TA team (me-251TA@groupe.epfl.ch)

7 PhD teaching assistants

Igor Reshetnikov (PhD)
Lorenzo Piersante (PhD)
Deepak Somani (PhD)
Takehiro Shiraishi (PhD)
Farkhondeh Khodabandeh (PhD)
Guilherme Da Silveira Ribeiro Bruges (PhD)
Léo Mutschler (PhD)

9 MSc/BSc student assistants

Aristide Paul Marc Vignon (MSc)
Thibault François Jean Andriot (MSc)
Margherita Eva Conte (MSc)
Nathan Romain Jamier (BSc)
Erik Maffei (MSc)
Michel Sabbagha (BSc)
Céline Miriam Jakob (BSc)
Nadine Stella Rüttimann (BSc)
Giovanni Luca Niccoló Mancini Griffoli (BSc)

Zhengmao Lu EPFL > STI > IGM > **ETA-Lab**

Leverage phase change heat/mass transfer to address the challenge of sustainability

Generation

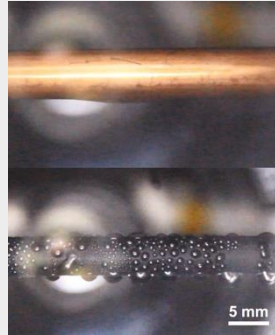

Condensation

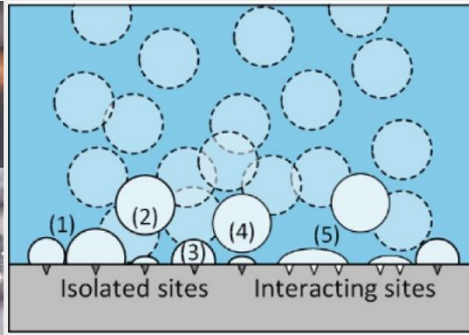

Boiling

Storage

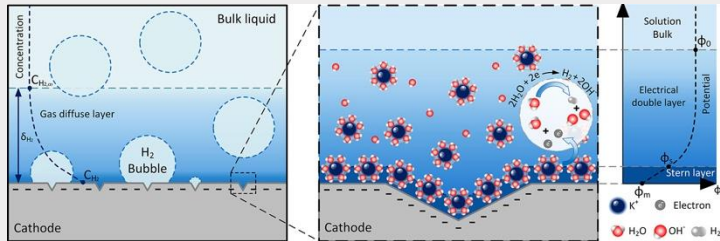

Alkaline water electrolysis

Usage

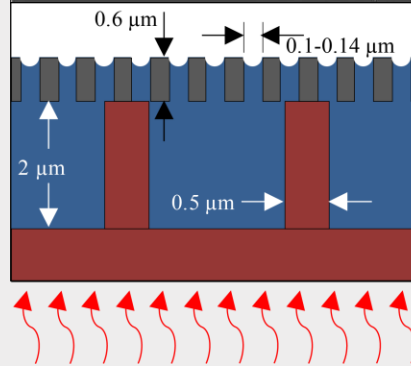
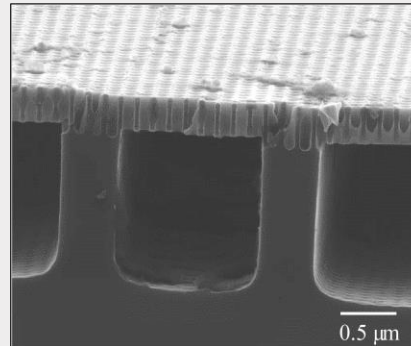

Electronics cooling

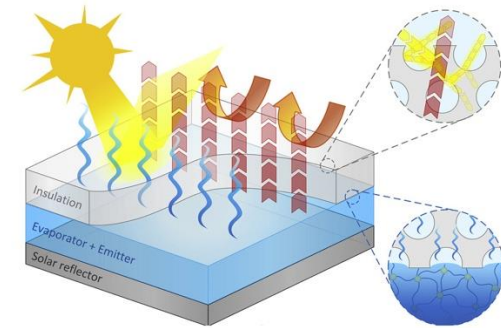
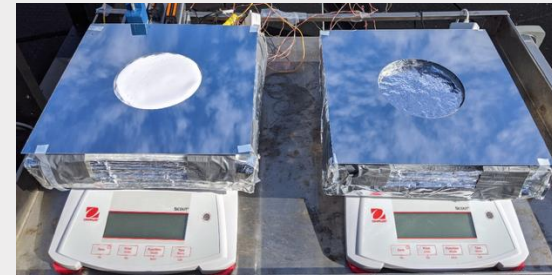

Passive subambient cooling

nanometer

millimeter

meter



Interface

Device

System

Interface accommodation

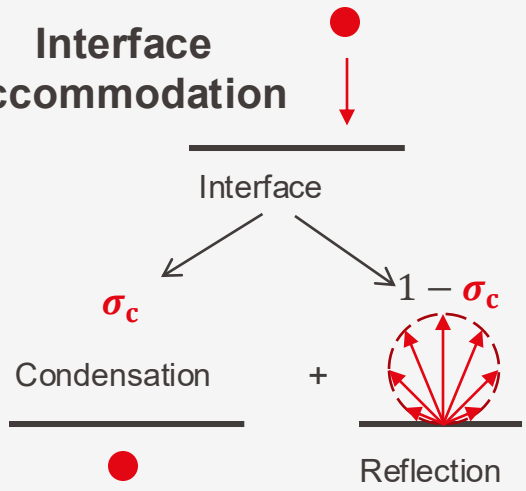

Nucleation process

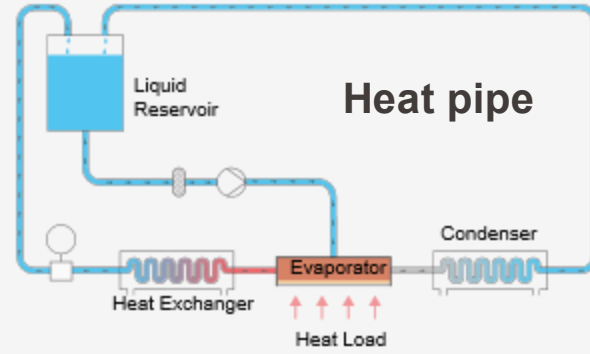
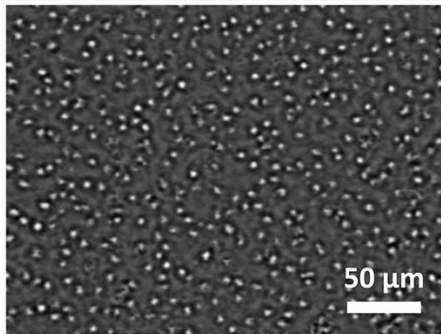

Boiling bubble dynamics



Cooling energy saving

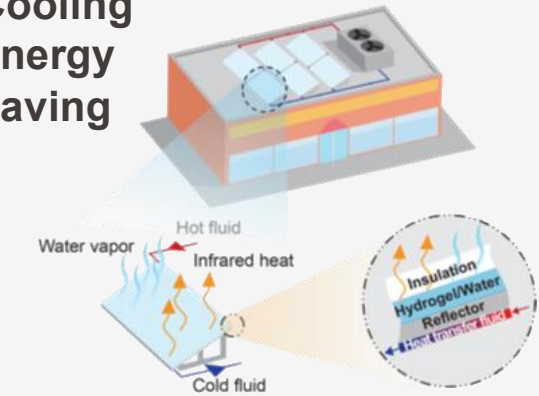

- Course will be taught in English (lectures, exercises, exams,...)

- Lectures
 - Monday 9h15-10h and 10h15-11h, BCH 2201
 - Wednesday 13h15-14h, RLC E1 240
 - Course will be live streamed (link published on Moodle)
 - Recordings will be posted on Mediaspace (link published on Moodle)
 - Course slides will be uploaded to Moodle
 - Moodle: **make sure you can access Moodle! Important course info will be announced through Moodle.**



■ Exercise







- Wednesday 14h15-15h, 3 different classrooms (AAC137, SG0211, SG0213)
- Exercise problems will be posted every Friday
(First set of exercise problems posted on Moodle already)
- Room assignment will be announced by September 9, 2025



- Office hours
 - I will be available 11h-12h after Monday lectures (BCH 2201)
 - TA office hour: 12h-13h before Wednesday lectures (ME B1 10)

- Exam: 3 hours written exam during the exam period
 - Will be closely related to exercise problems.
 - There will be a review session toward the end of the semester.
 - You are allowed to bring a cheat sheet (one A4 paper double-sided or two A4 papers single-sided) and a **calculator** with you to the exam.

ed EPFL ME-251 – Ed Discussion

 New Thread



COURSES +

ME-251

CATEGORIES

- General
- Lectures
- Exercises

Filter ▾

 Before you get started here

General Zhengmao Lu STAFF 7h

Hi everyone,

We're using Ed Discussion for out-of-class Q&A.

If you cannot come to office hours in person, this is the best place to ask questions about the course, whether curricular or administrative.

Here are some tips:

- Search before you post
- Use informative titles
(e.g., "Ex3 Q3(b): confusion about boundary conditions")
- Heart questions and answers you find useful
- Answer questions you feel confident answering
- Share interesting course related content with staff and peers

For more information on Ed Discussion, you can refer to the [Quick Start Guide](#).

All the best this semester!

Zhengmao

UNPIN
STAR
WATCHING
43
VIEWS

 14 others online

Fundamentals of Engineering
Thermodynamics, 7th Edition by
Moran, Shapiro, Boettner, Bailey.
(Moran)

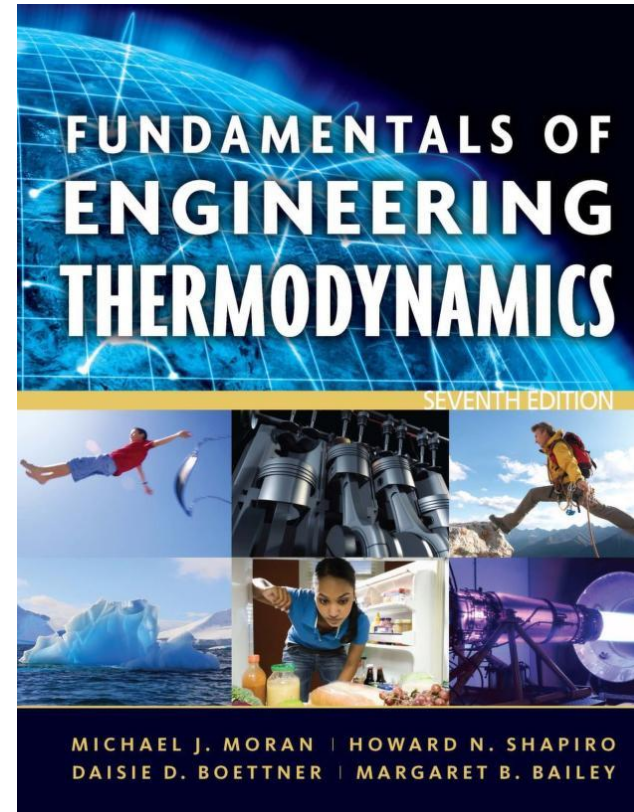

- AI tools may be used to support your learning, but they should not replace your own reasoning or understanding of thermodynamics.
- Don't trust AI (or perhaps anyone) blindly



Image generated by ChatGPT



■ Remarks:

- This is a hard and time-consuming course in a foreign language
- 4 credits $\approx 4 \times 30$ hours = 120 hours
14x4 hours lecture/exercise $\rightarrow 120 - 56 = 64$ hours outside the classroom



- Questions?



WIKIPEDIA
The Free Encyclopedia

Thermodynamics is a branch of physics that deals with heat, work, and temperature, and their relation to energy, entropy, and the physical properties of matter and radiation.



- General concepts
- 1st law for closed systems
- Thermodynamics properties
- 1st law for open systems
- Entropy and 2nd law for closed and open systems
- Exergy
- Applications (vapor power cycle, gas power system, refrigeration)
- Thermodynamic relations, mixtures, psychrometrics

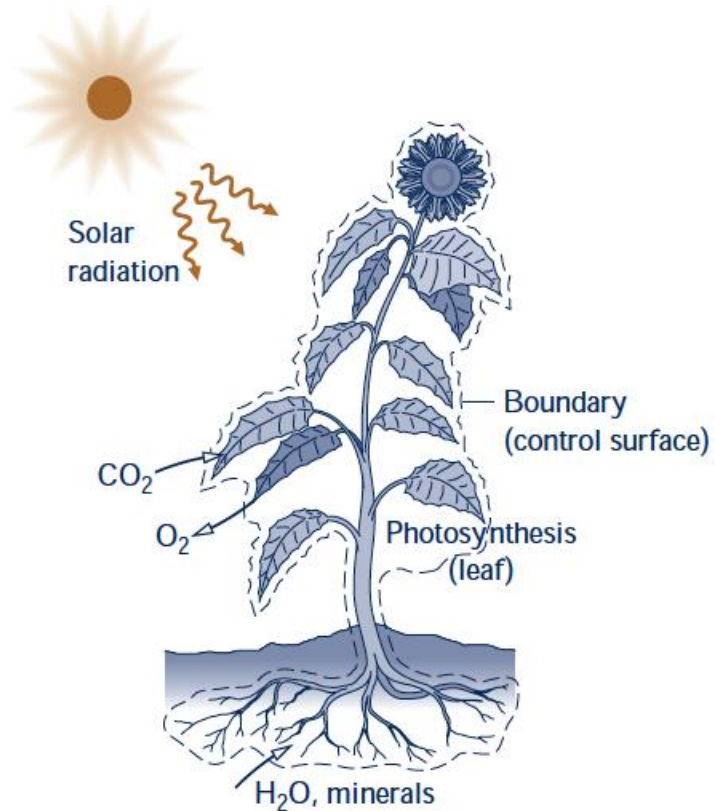

Can be intuitively understood as energy conservation

Energy change = Energy going in – Energy going out

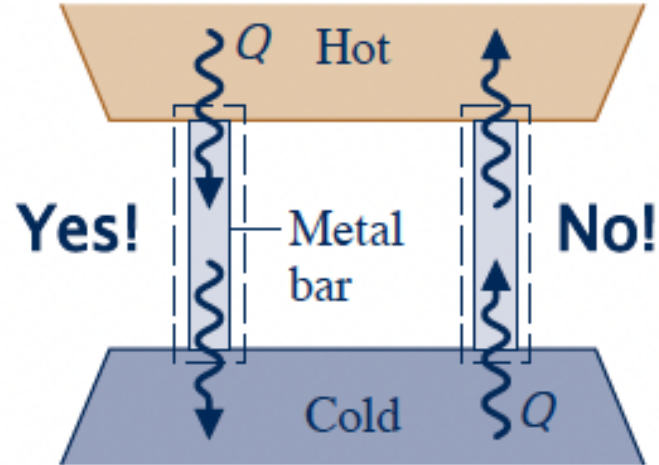

Clausius Statement of the Second Law

It's impossible for any system to operate in such a way that the sole result would be an energy transfer by heat from a cooler to a hotter body.

Why We Study Thermodynamics

World electricity generation

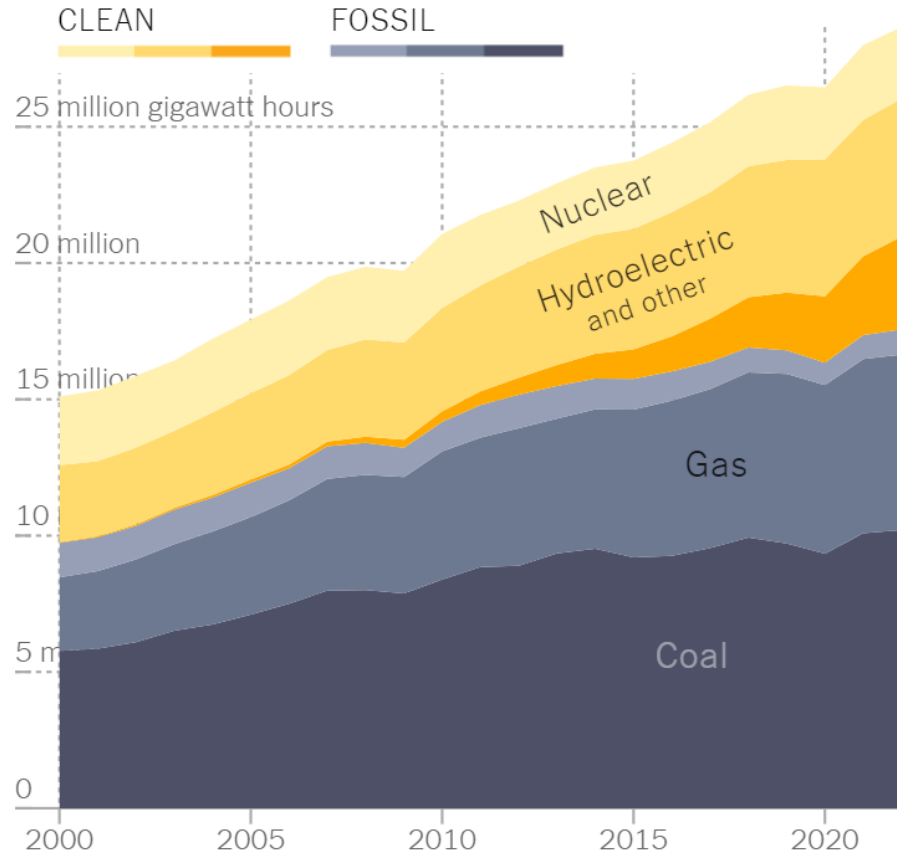

Wind and solar
Oil and other

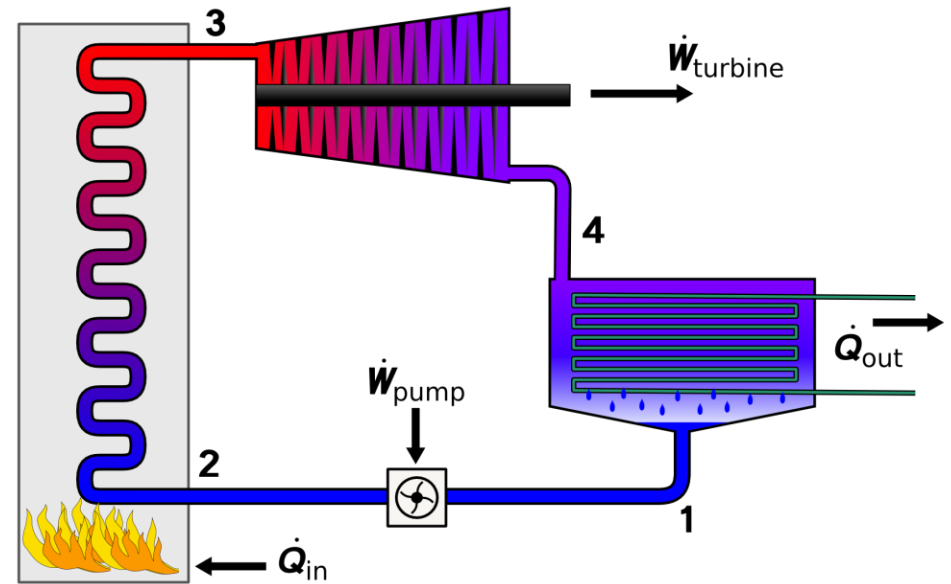

Credit: Andrew Ainsworth



Credit: Koza1983, CC BY 3.0

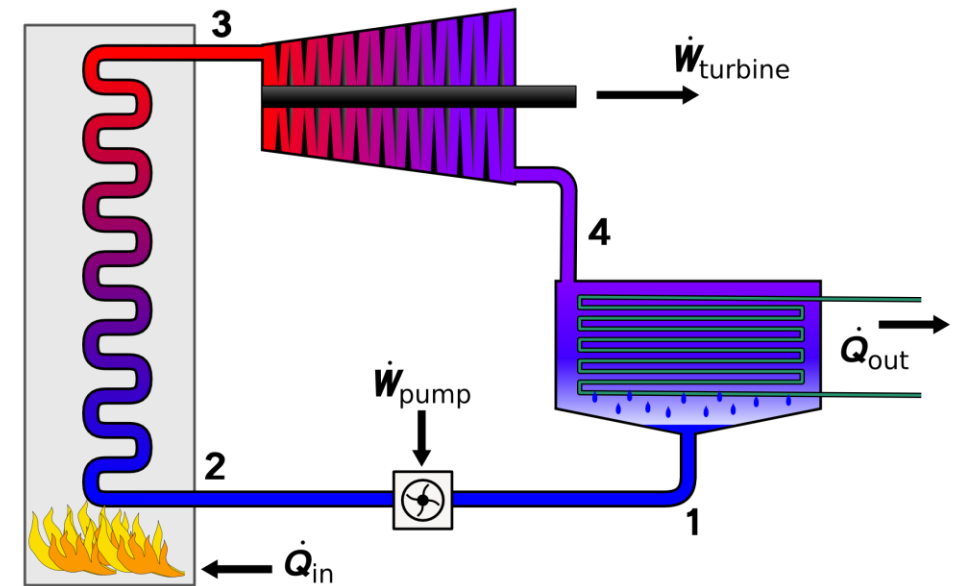

Credit: Andrew Ainsworth

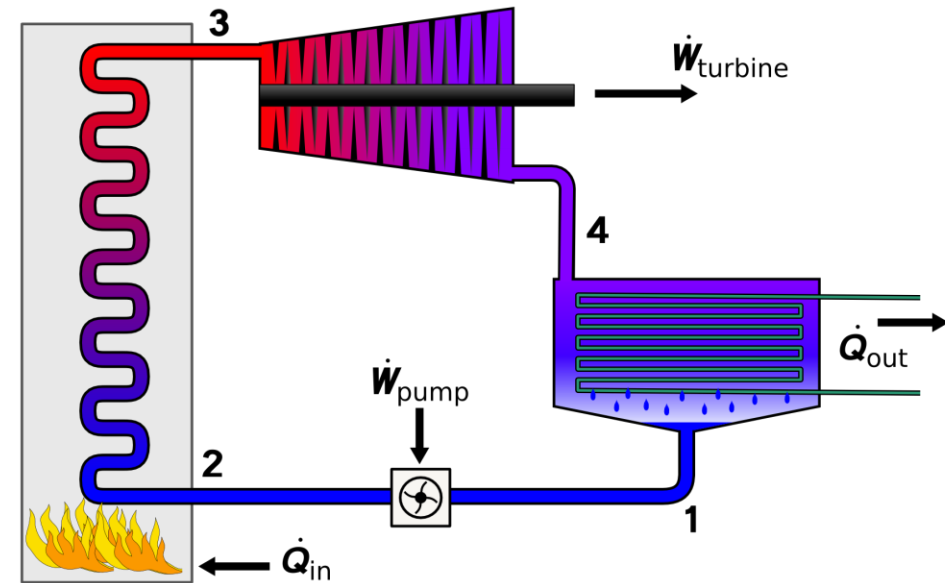

Credit: Andrew Ainsworth



Credit: Andrewglaser, CC BY-SA 3.0
Solar photovoltaic panels



Credit: Jérémy Toma, CC BY-SA 4.0
Hydroelectric dam in Valais

Thermodynamic analysis is needed for all forms of power generation technologies

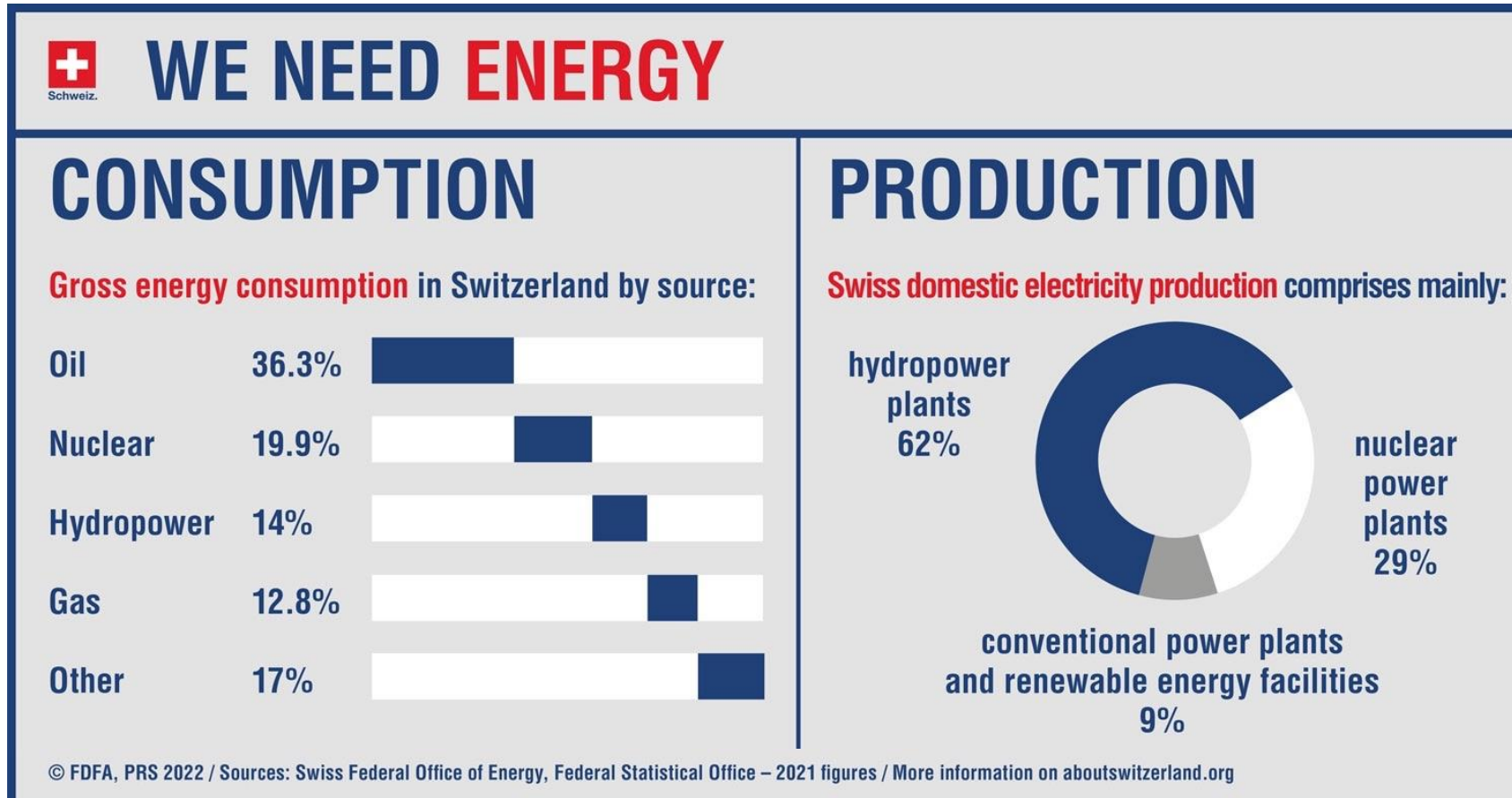



Aircraft

<https://www.swiss.com>



Train

<https://www.sbb.ch/>



Car

<https://www.mobility.ch>

Energy conversion for transportation requires thermodynamic analysis

Why We Study Thermodynamics



Cooling energy demand will **double** by 2050 with no action taken

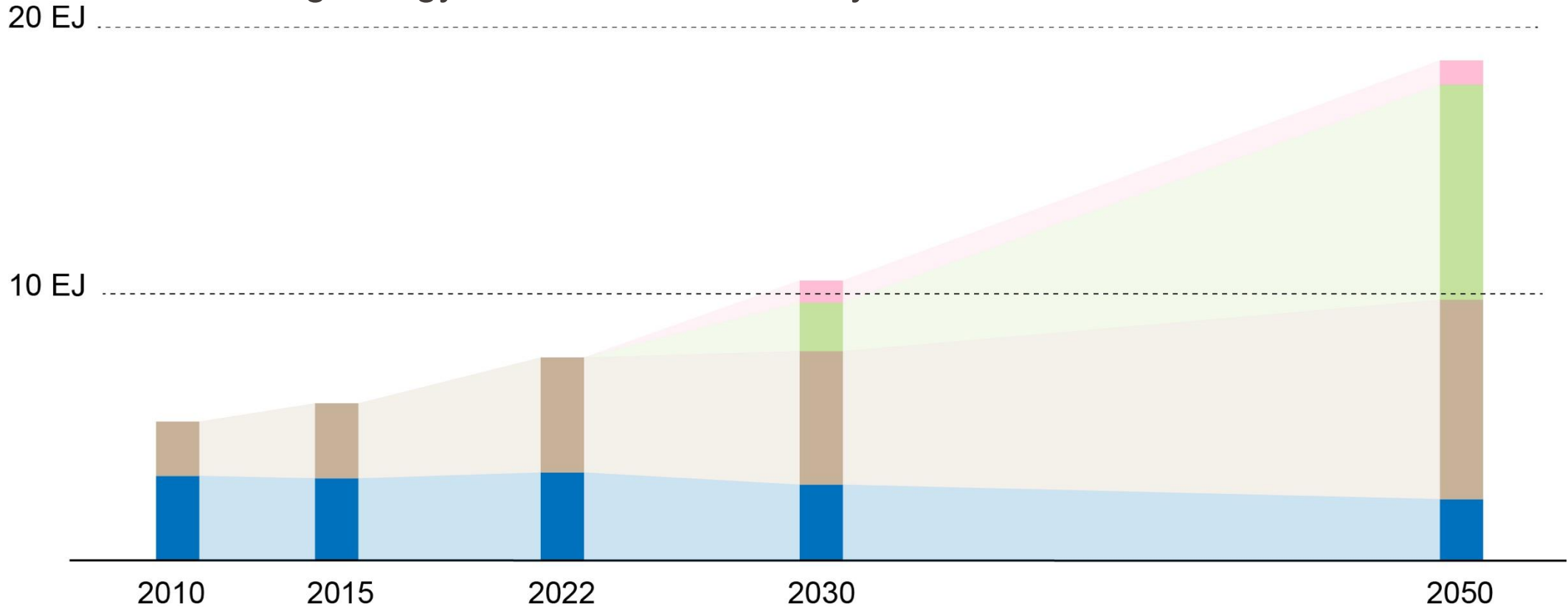

Energy consumption: ■ Advanced economies ■ Emerging market and developing countries
 Avoided consumption: ■ Energy efficiency ■ Behavioral change

Data Center

Market size expected to **double** by 2025



Cooling pipes in a Google data center
(Credit: Connie Zhou/Google/Zuma)

Improving cooling system's thermodynamic efficiency is critical to addressing the world's ever-increasing cooling demand

Why We Study Thermodynamics

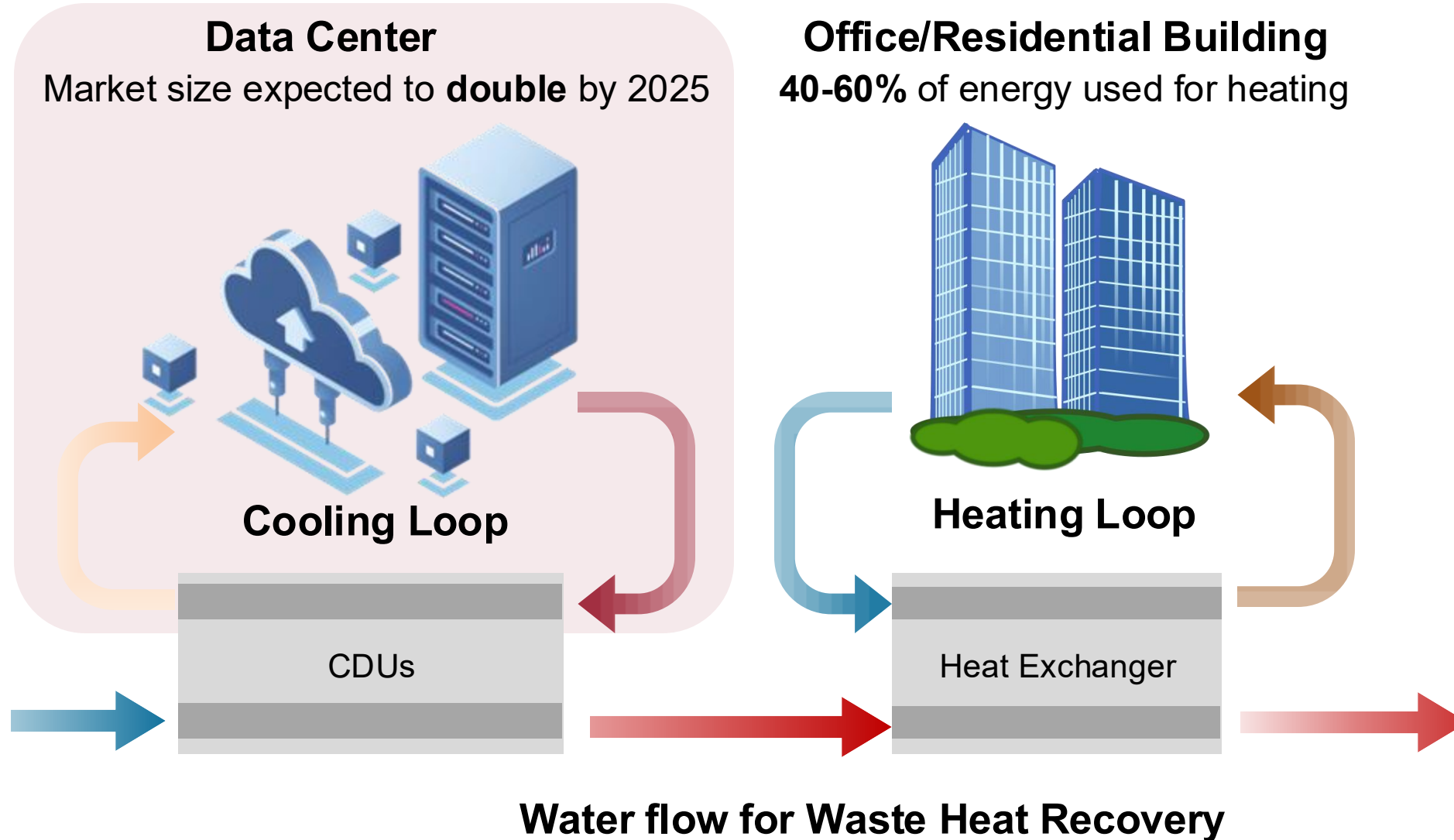

- Aircraft/rocket propulsion
- Alternative energy systems:
 - Fuel cells
 - Geothermal systems
 - Magnetohydrodynamic converters
 - Ocean thermal, wave, and tidal power generation
 - Solar-activated heating, cooling, and power generation
 - Thermoelectric and thermionic devices
 - Wind turbines
- Automobile engines
- Bioengineering applications
- Biomedical applications
- Combustion systems
- Compressors, pumps
- Cooling of electronic equipment
- Cryogenic systems, gas separation, and liquefaction
- Fossil and nuclear-fueled power stations
- HVAC systems
- Refrigeration and heat pumps
- Steam and gas turbines
- Power production
- Propulsion

Table 1.1 in Moran

- Understand the scope and the applications of thermodynamics

- Define and explain basic thermodynamics concepts
 - System, surrounding, boundary
 - Open vs closed systems
 - State, property, process, equilibrium
 - Intensive and extensive properties

○ Reading materials: **Moran** Chapter 1



WIKIPEDIA
The Free Encyclopedia

Thermodynamics is a branch of physics that deals with heat, work, and temperature, and their relation to energy, entropy, and the physical properties of matter and radiation.

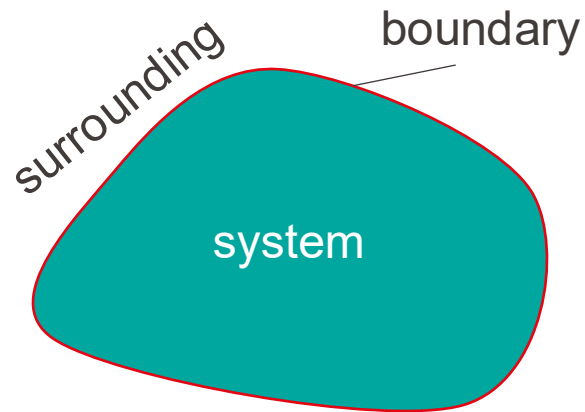

To perform thermodynamics analysis, we need to define the **system**, the **surrounding** and the **boundary** that separate the two

Piston-cylinder assembly

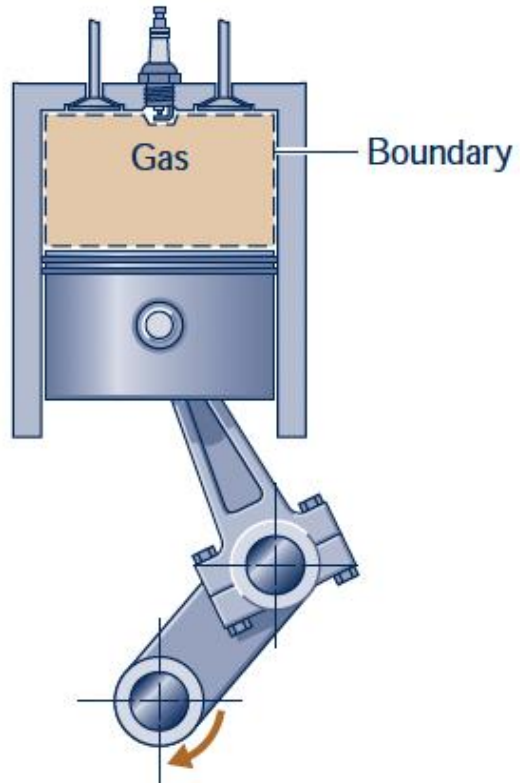

System:

Boundaries:

Surrounding:

Air compressor and storage tank

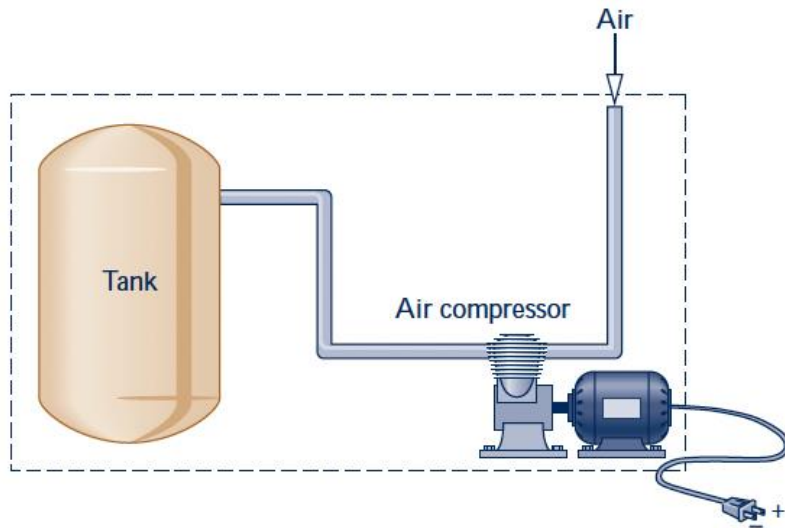

System: everything inside the dashed box

Boundaries:

Surrounding:

To join the session

Go to
echo360poll.eu

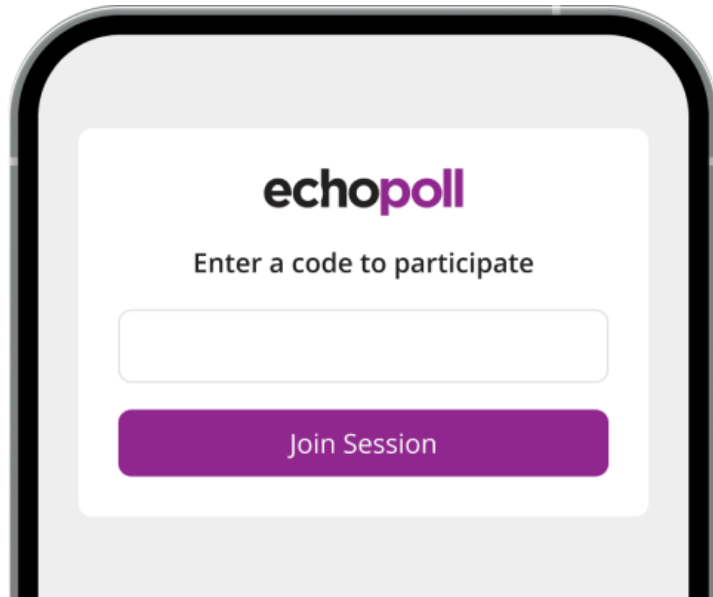

Enter Code
luepfl

Or scan the QR code with
your device



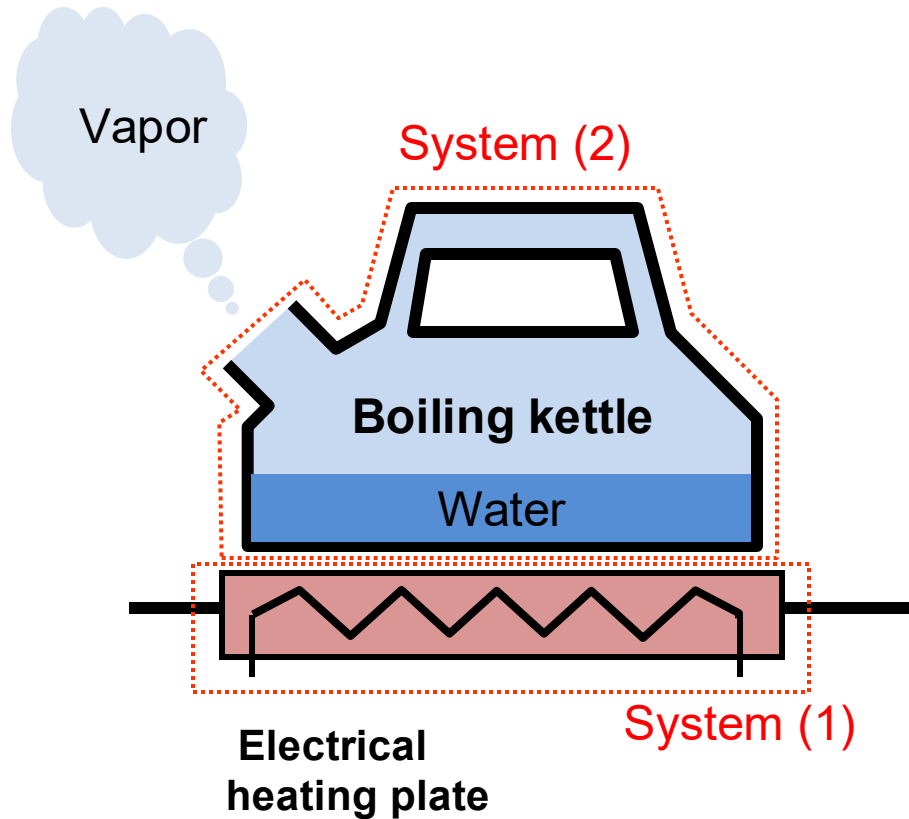

Which of the following statement is correct?

- A. (1) is an open system and (2) is a closed system
- B. (1) is an open system and (2) is an open system
- C. (1) is a closed system and (2) is a closed system
- D. (1) is a closed system and (2) is an open system

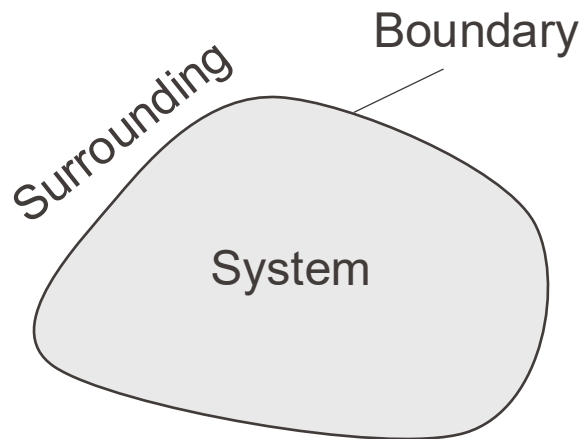

After identifying the system, we describe its **state** through a set of **thermodynamic properties/state functions** (internal energy, enthalpy, temperature, pressure,...)

We also study the **process** that marks the transformation from one state to another.

- A system is said to be in equilibrium when its properties do not change over time and there is no energy/mass flux across the boundaries
- At equilibrium, temperature and pressure (after accounting for hydrostatics) should be uniform
- ME-251 primarily studies equilibrium states and changes from one equilibrium state to another



Properties that are independent of the size of the system, such as

Temperature

Pressure

Density or specific volume



Wikipedia

Temperature is a physical quantity that expresses quantitatively the perceptions of **hotness and coldness**.

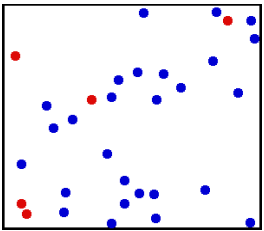

Kinetic theory

Temperature is proportional to the **average kinetic energy of the molecules**

Zeroth law: If two systems are both in thermal equilibrium with a third system, then they are in thermal equilibrium with each other

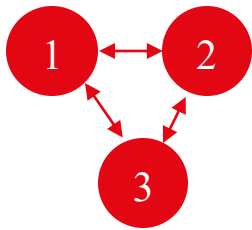

The zeroth law allows for **temperature measurement with a thermometer** that has measurable properties with known temperature dependence

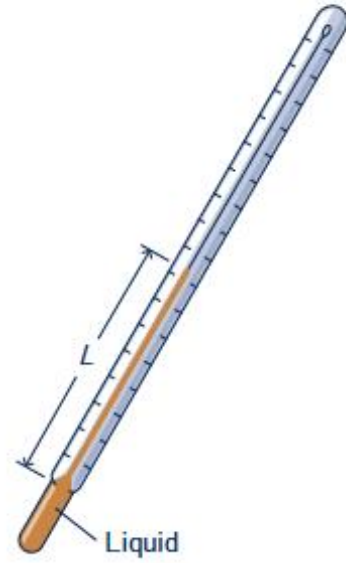

Liquid in glass



Electrical resistance



Infrared sensing

Celsius Scale ($^{\circ}\text{C}$)

0 $^{\circ}\text{C}$ for the freezing point of water at 1 atm pressure

100 $^{\circ}\text{C}$ for the boiling point of water at 1 atm pressure

Fahrenheit ($^{\circ}\text{F}$)

32 $^{\circ}\text{F}$ for the freezing point of water at 1 atm pressure

212 $^{\circ}\text{F}$ for the boiling point of water at 1 atm pressure

Kelvin (K)

0 K: lowest limit of thermodynamic temperature scale, -273.15°C

1 K interval is the same as 1 $^{\circ}\text{C}$ interval

Microscopically linked to molecules hitting a surface

Macroscopically defined as normal force exerted by a fluid per unit area

$$p = F_{normal}/A$$

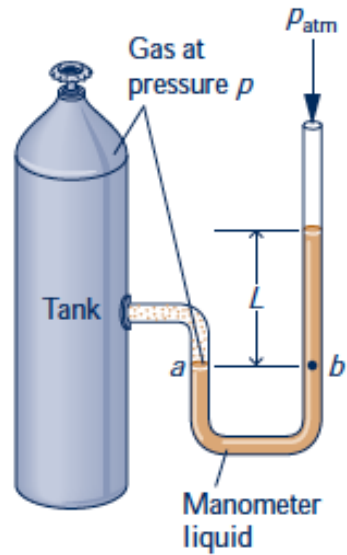

Manometer

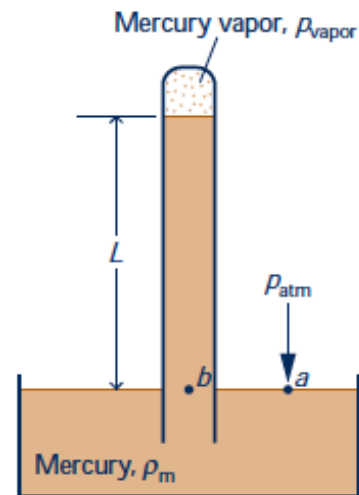

Barometer

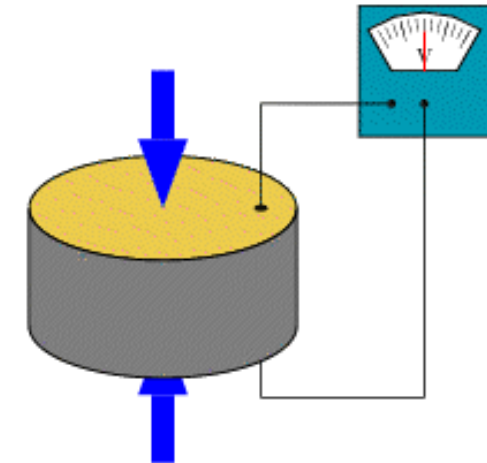

Credit: Tizeff, CC BY-SA 3.0

Piezoelectric sensor

Continuum hypothesis: the description of matter can be simplified by considering it to be distributed continuously throughout a region.

Density $\rho = m/V$ mass per unit volume

Specific volume $v = 1/\rho$ volume per unit mass

Microscopically, density corresponds to the statistical average of the mass of particles in a unit volume

Phenomenological description based on experimental observations of macroscopic systems and matters

Statistical treatment based on the average behavior of a large group microscopic particles.



The magnitude of an intensive property is independent of the size of the system:
Temperature, pressure, specific volume, ...

A property is called extensive if its value for an overall system is the sum of its values for the parts into which the system is divided:

When you combine two systems into one, you can add up extensive properties

- Understand the scope and the applications of thermodynamics

- Define and explain basic thermodynamics concepts
 - System, surrounding, boundary
 - Open vs closed systems
 - State, property, process, equilibrium
 - Intensive and extensive properties

○ Reading materials: **Moran** Chapter 1

- Explain key concepts in the 1st law of thermodynamics
 - Energy change
 - Work
 - Heat