

Thermodynamics and energetics 1

Prof. Sophia Haussener

Laboratory of Renewable Energy Sciences and Engineering

Summary last lecture

- Understand and demonstrate key concept of exergy and exergy analysis
- Evaluate exergy at a state and exergy changes between two states
- Apply exergy balances to closed systems

Learning outcomes of today's lecture

- Understand and demonstrate key concept of exergy and exergy analysis
- Evaluate exergy at a state and exergy changes between two states
- Apply exergy balances to closed and open systems
- Define and evaluate exergetic efficiencies

Exergy balance for open systems

- Open systems:

- 1st law: $\frac{dE}{dt} = \dot{Q}_0 + \sum_j \dot{Q}_j - \dot{W}$

$$+ \sum_i \dot{m}_i \left(h_i + \frac{w_i^2}{2} + gz_i \right) - \sum_e \dot{m}_e \left(h_e + \frac{w_e^2}{2} + gz_e \right)$$

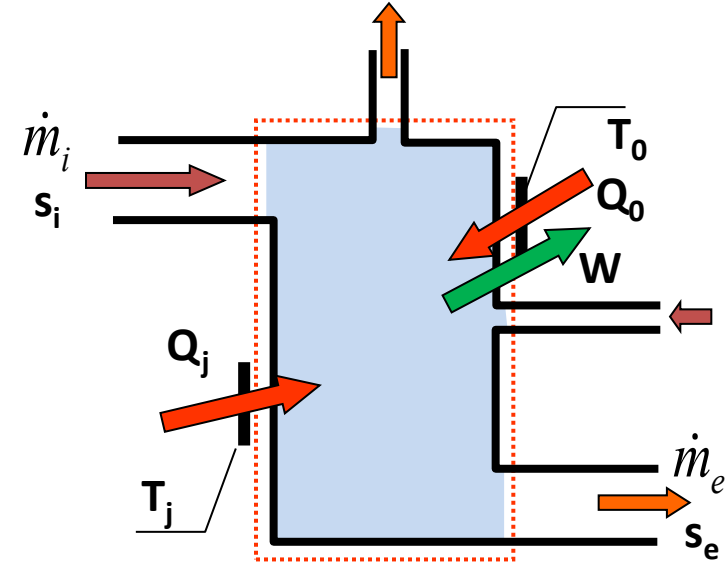

- 2nd law: $\frac{dS}{dt} = \frac{\dot{Q}_0}{T_0} + \sum_j \frac{\dot{Q}_j}{T_j} + \sum_i \dot{m}_i s_i - \sum_e \dot{m}_e s_e + \dot{\sigma}$

- Usable work:

$$\dot{W}_{rev, usable} = \dot{W}_{rev} - p_0 \frac{dV}{dt} = \dot{W} + T_0 \dot{\sigma} - p_0 \frac{dV}{dt}$$

Exergy balance for open systems

- Open systems – Exergy
 - Combine 1st and 2nd law

$$\frac{dE}{dt} = T_0 \left(\frac{dS}{dt} - \sum_j \frac{\dot{Q}_j}{T_j} - \sum_i \dot{m}_i s_i + \sum_e \dot{m}_e s_e - \dot{\sigma} \right) + \sum_j \dot{Q}_j - \dot{W} \\ + \sum_i \dot{m}_i \left(h_i + \frac{w_i^2}{2} + gz_i \right) - \sum_e \dot{m}_e \left(h_e + \frac{w_e^2}{2} + gz_e \right)$$

- Include definition of work:

$$\frac{dE}{dt} = T_0 \left(\frac{dS}{dt} - \sum_j \frac{\dot{Q}_j}{T_j} - \sum_i \dot{m}_i s_i + \sum_e \dot{m}_e s_e - \dot{\sigma} \right) + \sum_j \dot{Q}_j - \left(\dot{W}_{rev\ usable} + p_0 \frac{dV}{dt} - T_0 \dot{\sigma} \right) \\ + \sum_i \dot{m}_i \left(h_i + \frac{w_i^2}{2} + gz_i \right) - \sum_e \dot{m}_e \left(h_e + \frac{w_e^2}{2} + gz_e \right)$$

Exergy balance for open systems

- Open systems – Exergy

- Reorder:

$$\frac{dE}{dt} - T_0 \frac{dS}{dt} + p_0 \frac{dV}{dt} = \sum_j \left(1 - \frac{T_0}{T_j} \right) \dot{Q}_j - \dot{W}_{rev\ usable} + \sum_i \dot{m}_i \left(h_i + \frac{w_i^2}{2} + gz_i - T_0 s_i \right) - \sum_e \dot{m}_e \left(h_e + \frac{w_e^2}{2} + gz_e - T_0 s_e \right)$$

- Remember definition of exergy:

$$ex = u - u_0 + ke + pe - T_0 (s - s_0) + p_0 (v - v_0)$$

- And introduce flow exergy:

$$ex_f = u - u_0 + ke + pe - T_0 (s - s_0) + p_0 (v - v_0) + (p - p_0)v$$

$$ex_f = h - h_0 + ke + pe - T_0 (s - s_0)$$

$$ex_f = ex + (p - p_0)v$$

Exergy balance for open systems

- Open systems – Exergy:

$$\frac{dEx}{dt} = \sum_j \left(1 - \frac{T_0}{T_j} \right) \dot{Q}_j - \dot{W}_{rev\ usable} + \sum_i \dot{m}_i ex_{f,i} - \sum_e \dot{m}_e ex_{f,e}$$

– Or:

$$\frac{dEx}{dt} = \sum_j \left(1 - \frac{T_0}{T_j} \right) \dot{Q}_j - \left(\dot{W} - p_0 \frac{dV}{dt} \right) + \underbrace{\sum_i \dot{m}_i ex_{f,i} - \sum_e \dot{m}_e ex_{f,e}}_{\text{Convective exergy transfer at the inlets and outlets}} - T_0 \dot{\sigma}$$

Change in
exergy
within the
volume

=

Exergy transfer
via heat
transfer

-

Exergy transfer
via work

+

Convective
exergy transfer
at the inlets and
outlets

-

Exergy
destruction due
to
irreversibilities

Exergy balance for open systems

- Open systems – Exergy:
 - Steady-state:

$$0 = \sum_j \left(1 - \frac{T_0}{T_j} \right) \dot{Q}_j - \dot{W} + \sum_i \dot{m}_i ex_{f,i} - \sum_e \dot{m}_e ex_{f,e} - T_0 \dot{\sigma}$$

- Steady state, one inlet and one outlet port:

$$0 = \sum_j \left(1 - \frac{T_0}{T_j} \right) \dot{Q}_j - \dot{W} + \dot{m}(ex_{f,i} - ex_{f,e}) - T_0 \dot{\sigma}$$

$$0 = \sum_j \left(1 - \frac{T_0}{T_j} \right) \dot{Q}_j - \dot{W} + \dot{m}(h_i - h_e - T_0(s_i - s_e) + 0.5(w_i^2 - w_e^2) + g(z_i - z_e)) - T_0 \dot{\sigma}$$

Exergy balance for open systems

- Example (7.3): Compressed air enters a counter-flowing heat exchanger. A separate stream of hot combustion gas (mainly air) enters the heat exchanger from the other side. Both streams have a mass flow rate of 90 kg/s. Determine the exergy destroyed in the heat exchanger system. $T_0=300\text{K}$, $p_0=1\text{bar}$.

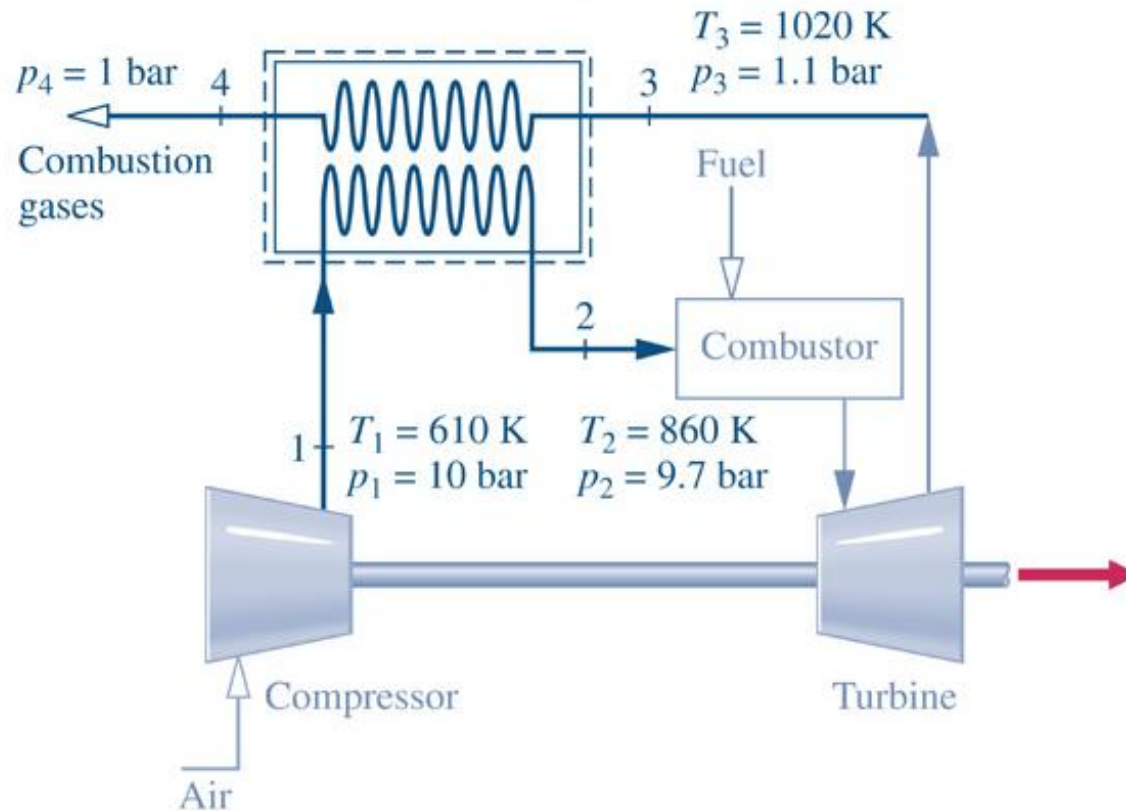

$$Ex_d/m = 2.83\text{ MW}$$

Exergetic efficiency

- Exergy efficiency describes the effectiveness of energy resource utilization

$$\varepsilon_{ex} = \frac{\text{used exergy}}{\text{provided exergy}}$$

- Note: energy efficiency

$$\eta = \frac{\text{used energy}}{\text{provided energy}}$$

Exergetic efficiency

- Exergy efficiency

- 1st law: $0 = \dot{Q}_s - \dot{Q}_u - \dot{Q}_l$

- Exergy balance:

$$0 = \left(1 - \frac{T_0}{T_s}\right) \dot{Q}_s - \left(1 - \frac{T_0}{T_u}\right) \dot{Q}_u - \left(1 - \frac{T_0}{T_l}\right) \dot{Q}_l - T_0 \dot{\sigma}$$

Provided exergy
Used exergy
Lost exergy

- Example:

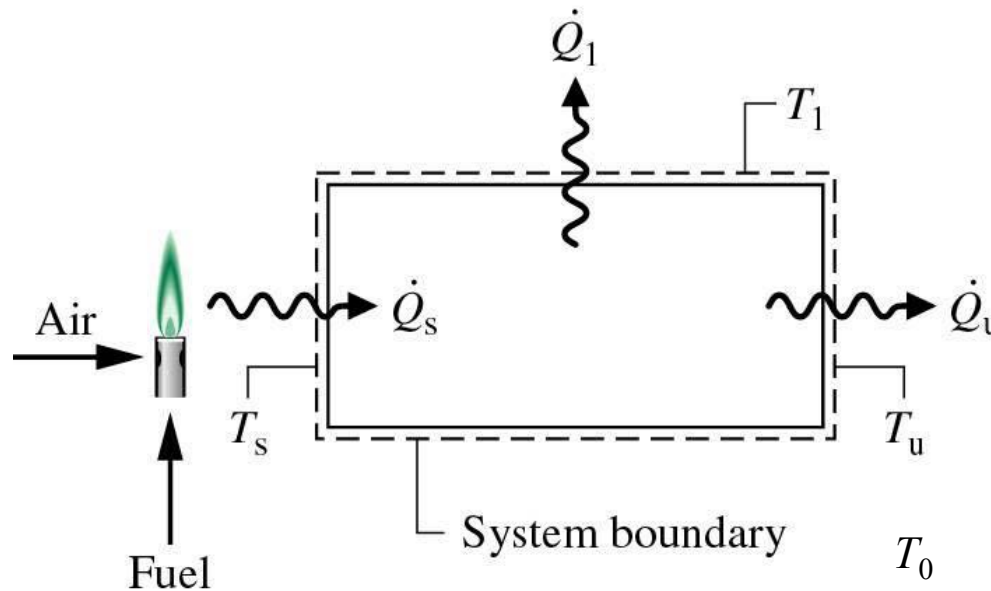

Exergetic efficiency

- Exergy efficiency describes the effectiveness of energy resource utilization

- Energy efficiency: $\eta = \frac{Q_u}{Q_s}$

- Exergy efficiency: $\epsilon_{ex} = \frac{(1 - T_0 / T_u) \dot{Q}_u}{(1 - T_0 / T_s) \dot{Q}_s} = \eta \frac{(1 - T_0 / T_u)}{(1 - T_0 / T_s)}$

- Influence of T_u , $T_s = 2200 \text{ K}$, $\eta = 100 \%$:

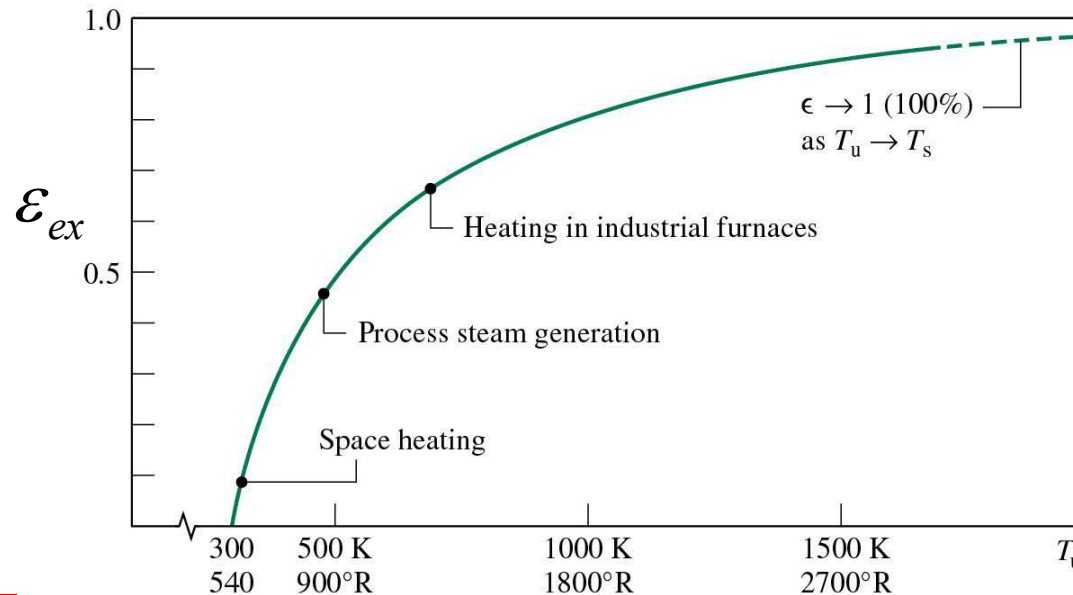

Exergetic efficiency

- Exergy efficiency

- Turbine: $0 = -\dot{W}_{cv} + \dot{m}(ex_{f,i} - ex_{f,e}) - T_0 \dot{\sigma}$

$$\varepsilon_{ex} = \frac{(\dot{W} / \dot{m})}{ex_{f,i} - ex_{f,e}}$$

- Compressor and pumps:

$$\varepsilon_{ex} = \frac{ex_{f,e} - ex_{f,i}}{(-\dot{W}_{cv} / \dot{m})}$$

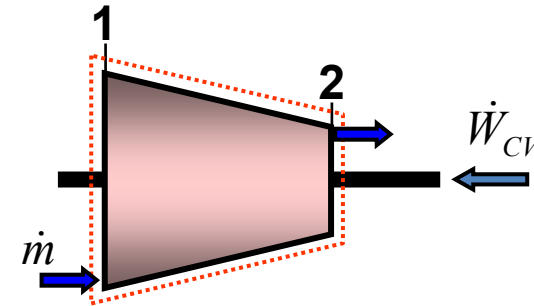
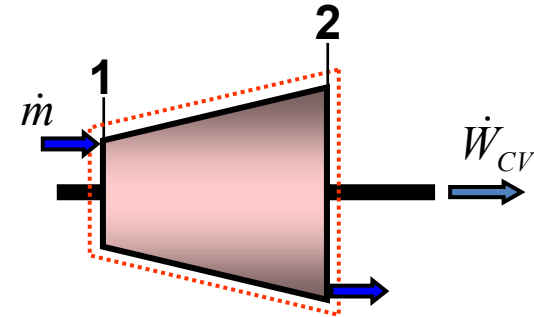

Exergy balance for open systems

- Example (7.4): A steam turbine with inlet temperature of 320 °C and pressure of 5 bar and exit pressure of 1 bar has an isentropic turbine efficiency of 75%. Calculate its exergetic efficiency. $T_0=300\text{K}$, $p_0=1\text{bar}$.

$$\eta_{\text{ex}}=81\%$$

Exergetic efficiency

- Exergy efficiency
 - Heat exchanger, non-mixing:

$$0 = \dot{m}_h (ex_{f,i,h} - ex_{f,e,h}) + \dot{m}_c (ex_{f,i,c} - ex_{f,e,c}) - T_0 \dot{\sigma}$$

$$\varepsilon_{ex} = \frac{\dot{m}_c (ex_{f,e,c} - ex_{f,i,c})}{\dot{m}_h (ex_{f,i,h} - ex_{f,e,h})}$$

- Heat exchanger, mixing :

$$\varepsilon_{ex} = \frac{\dot{m}_2 (ex_{f,3} - ex_{f,2})}{\dot{m}_1 (ex_{f,1} - ex_{f,3})}$$

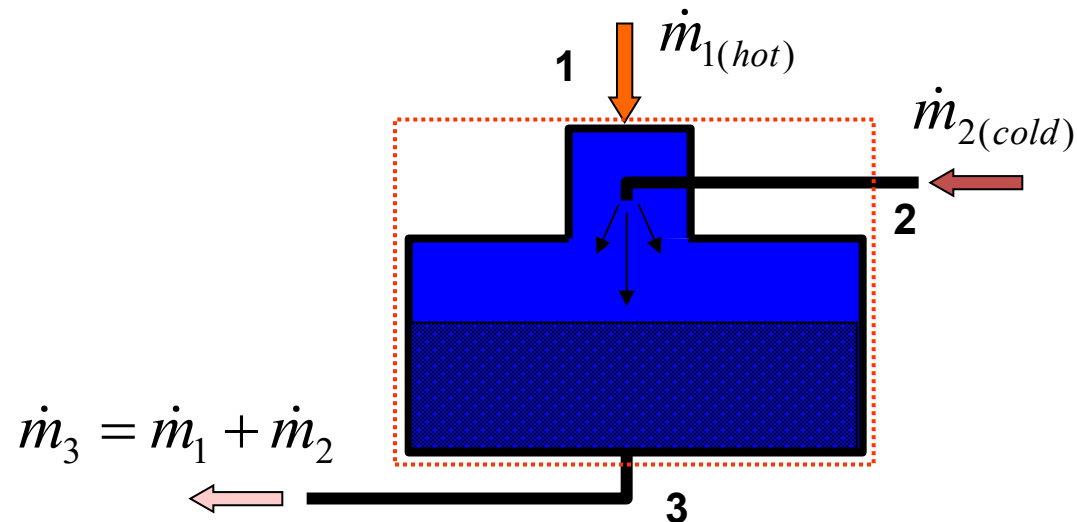
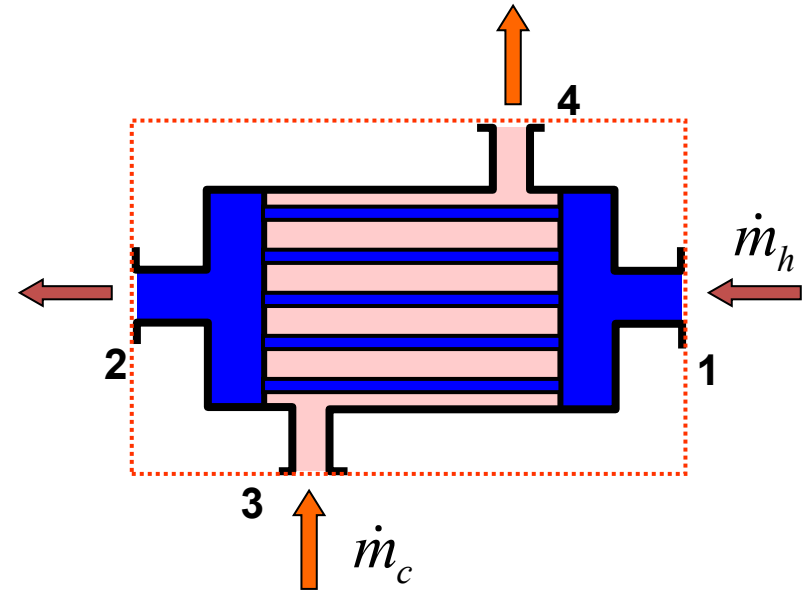

Exergetic efficiency

- How to increase exergetic efficiency:
Cogeneration, power recovery, waste heat recovery

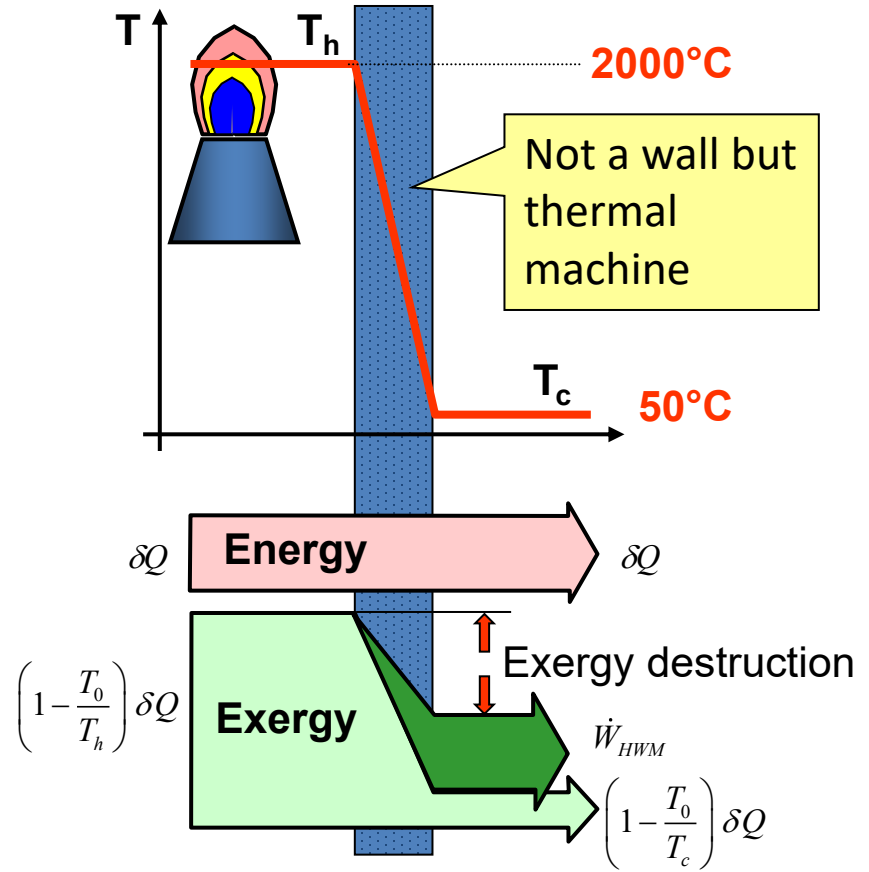
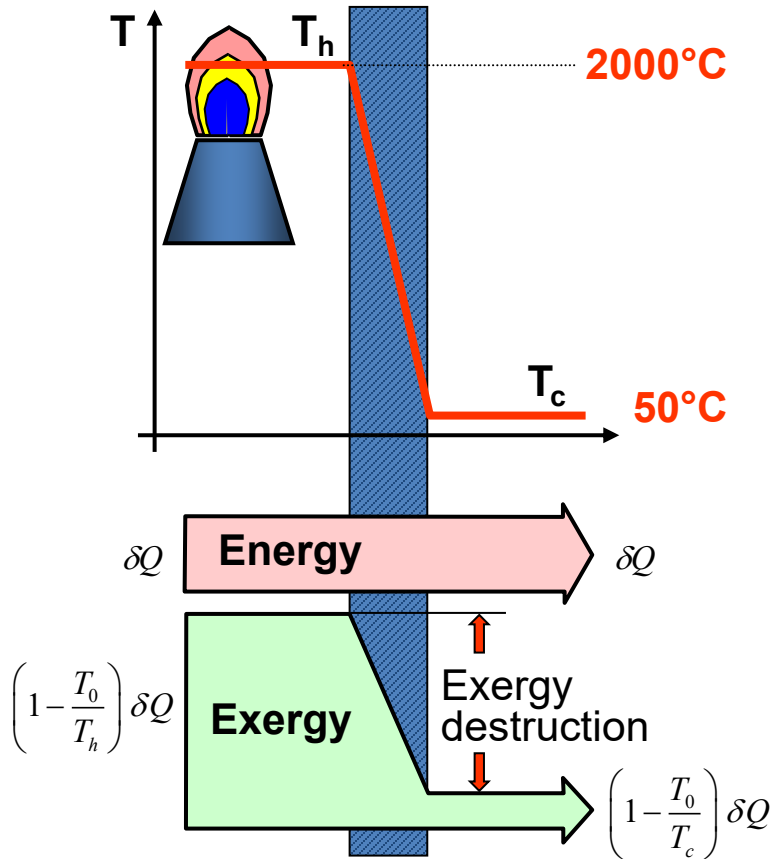

Learning outcomes of lecture

- Understand and demonstrate key concept of exergy and exergy analysis

- Evaluate exergy at a state and exergy changes between two states:

$$Ex = U - U_0 + KE + PE - T_0 (S - S_0) + p_0 (V - V_0)$$

$$Ex_2 - Ex_1 = (U_2 - U_1) + (KE_2 - KE_1) + (PE_2 - PE_1) - T_0 (S_2 - S_1) + p_0 (V_2 - V_1)$$

- Apply exergy balances to closed and open systems:

$$\frac{dEx}{dt} = \sum_j \left(1 - \frac{T_0}{T_j} \right) \dot{Q}_j - \left(\dot{W} - p_0 \frac{dV}{dt} \right) + \sum_i \dot{m}_i ex_{f,i} - \sum_e \dot{m}_e ex_{f,e} - T_0 \dot{\sigma}$$

- Define and evaluate exergetic efficiencies:

$$\varepsilon_{ex} = \frac{\text{used exergy}}{\text{provided exergy}}$$