

Thermodynamics and energetics I: Exercise 13

In the first part of the exercise, you model and analyze ideal gas mixtures. In the second part of the exercise, you will work with mixtures made of air and water vapor.

1. A well insulated tank with two compartments is connected with a valve. Initially one compartment contains 1 kg H_2 at 300 K and 6 bar. The second compartment contains 4.667 kg N_2 at 600 K and 6 bar. When the valve is opened, the two gases mix and finally equilibrium is achieved.

- (a) What is the final temperature of the mixture?
- (b) What is the final pressure of the mixture?
- (c) What is the amount of entropy created?

Solve using $\tilde{c}_{v,H_2} = \text{const.} = 20.94 \text{ J}/(\text{mol K})$, $\tilde{c}_{v,N_2} = \text{const.} = 21.06 \text{ J}/(\text{mol K})$
Optional: For the case $c_v = c_v(T)$, solve using values of $u(T)$ obtained from CoolProp.

2. A device to separate the components of natural gas is considered. Natural gas is composed of CH_4 and C_2H_6 and enters the device at $100 \text{ m}^3/\text{s}$, 20°C and 1 bar. The molar fraction of C_2H_6 is denoted y and varies between 0.05 and 0.50. The device has two exits where the separated components exit at 20°C and 1 bar. Consider the dead state temperature (T_0) as 20°C .
 - (a) Compute the minimum theoretical work W_{min} that has to be supplied to the device as a function of y .
 - (b) Plot W_{min} as a function of y .

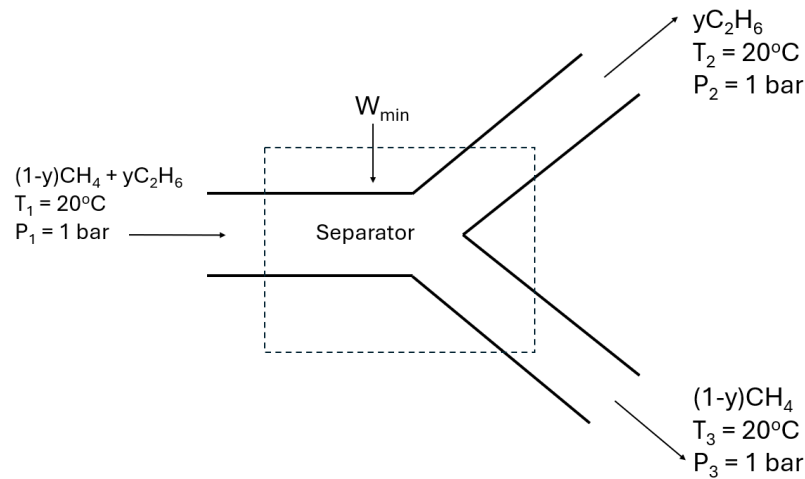

Figure 1: Schematic of the separator device.

3. A person with glasses enters a heated room at 20°C after spending some time in the cold (the glasses are at 2°C). The glasses start to fog.

- (a) Can you determine the exact value of the relative humidity?
- (b) Find the bounding values of the relative humidity of the room.

Hint: Use the psychrometric chart (Fig. 3).

4. Liquid water at 50°C is injected into a cooling tower. Cooled water leaves the tower at a massflow of 80 kg/min , evaporated water is not replaced. Atmospheric air is sucked into the tower at 17°C , 1 bar and 60% relative humidity at a volumetric flow rate of $101\text{ m}^3/\text{min}$. Saturated moist air leaves the tower at 30°C and 1 bar . The mechanical power exerted by the fan is 8 kW . Determine:

- (a) The mass-flow of water to the tower.
- (b) The temperature of the cooled water at the exit. First, calculate using the psychrometric chart. Second, use CoolProp. Compare the results.

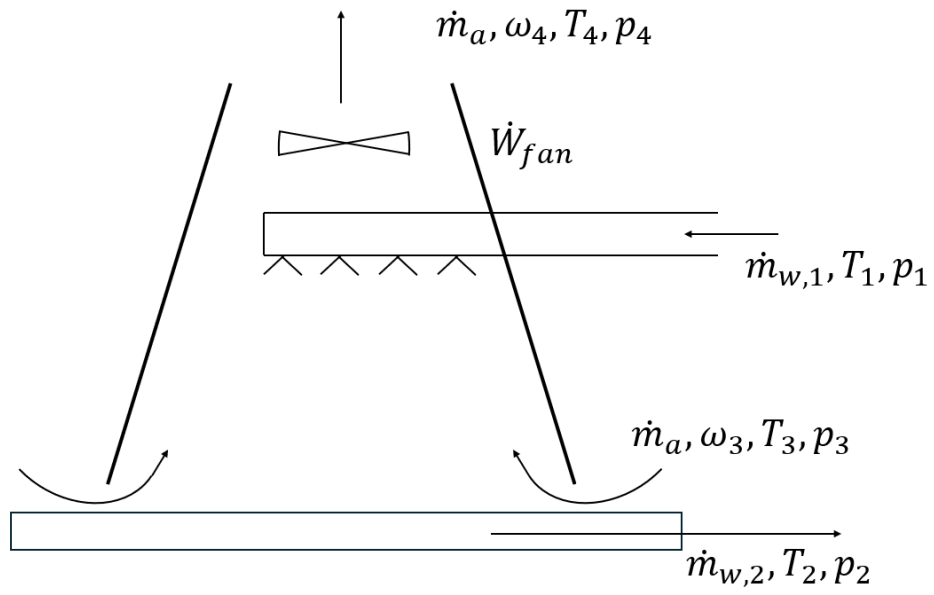

Figure 2: Schematic of the cooling tower.

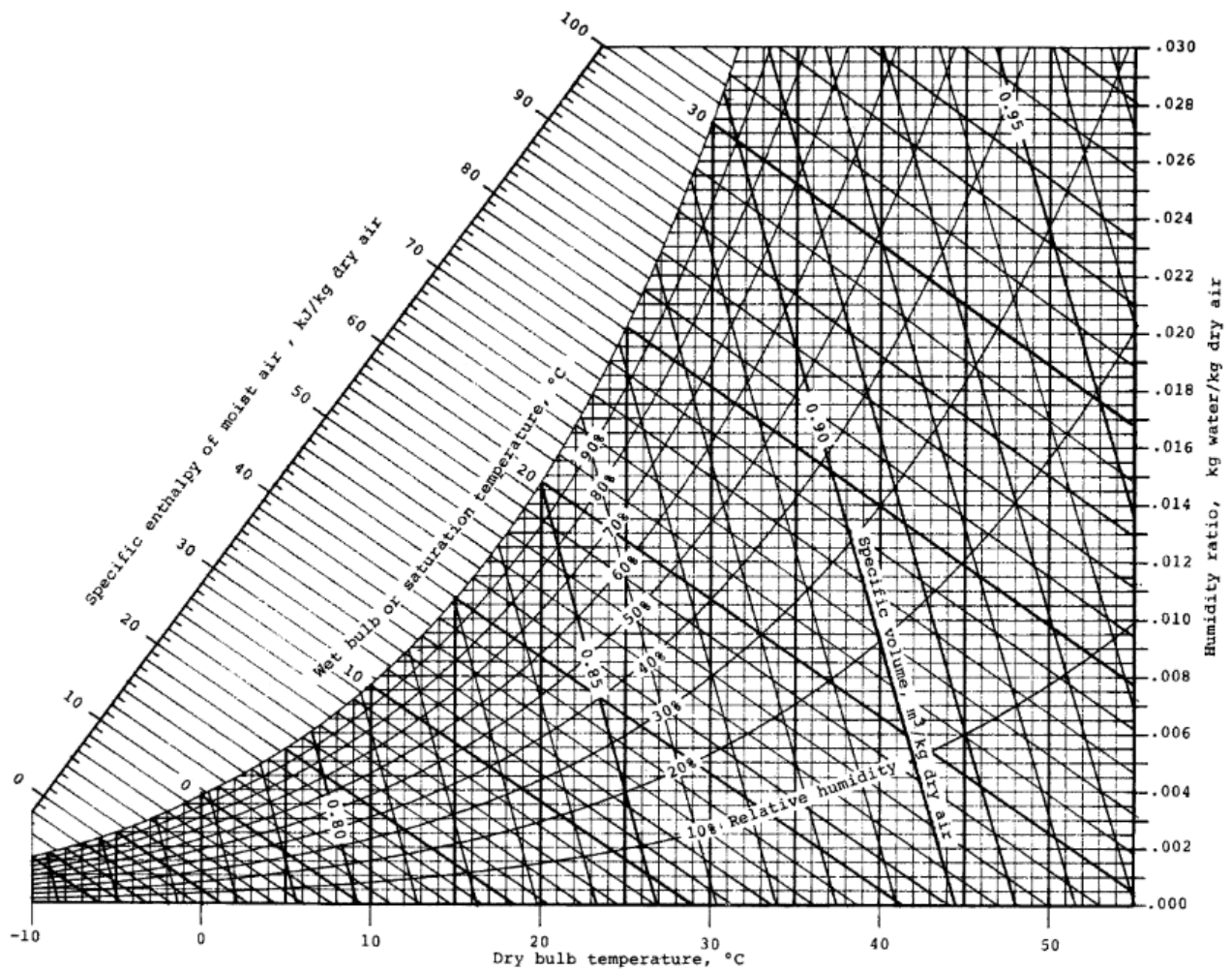

Figure 3: Psychrometric chart for 1 atm. Source: Z. Zhang and M. B. Pate, "A methodology for implementing a psychrometric chart in a computer graphics system", ASHRAE Transactions, Vol. 94, Pt. 1, 1988