

ENV-405 Session 2

Wastewater treatment

Lecture 1 Nov 4

Professor Wenyu Gu

Slides acknowledgment: Christof Holiger, Shilva Shrestha

Where does this course/session fit?

Section 1 Tony Merle

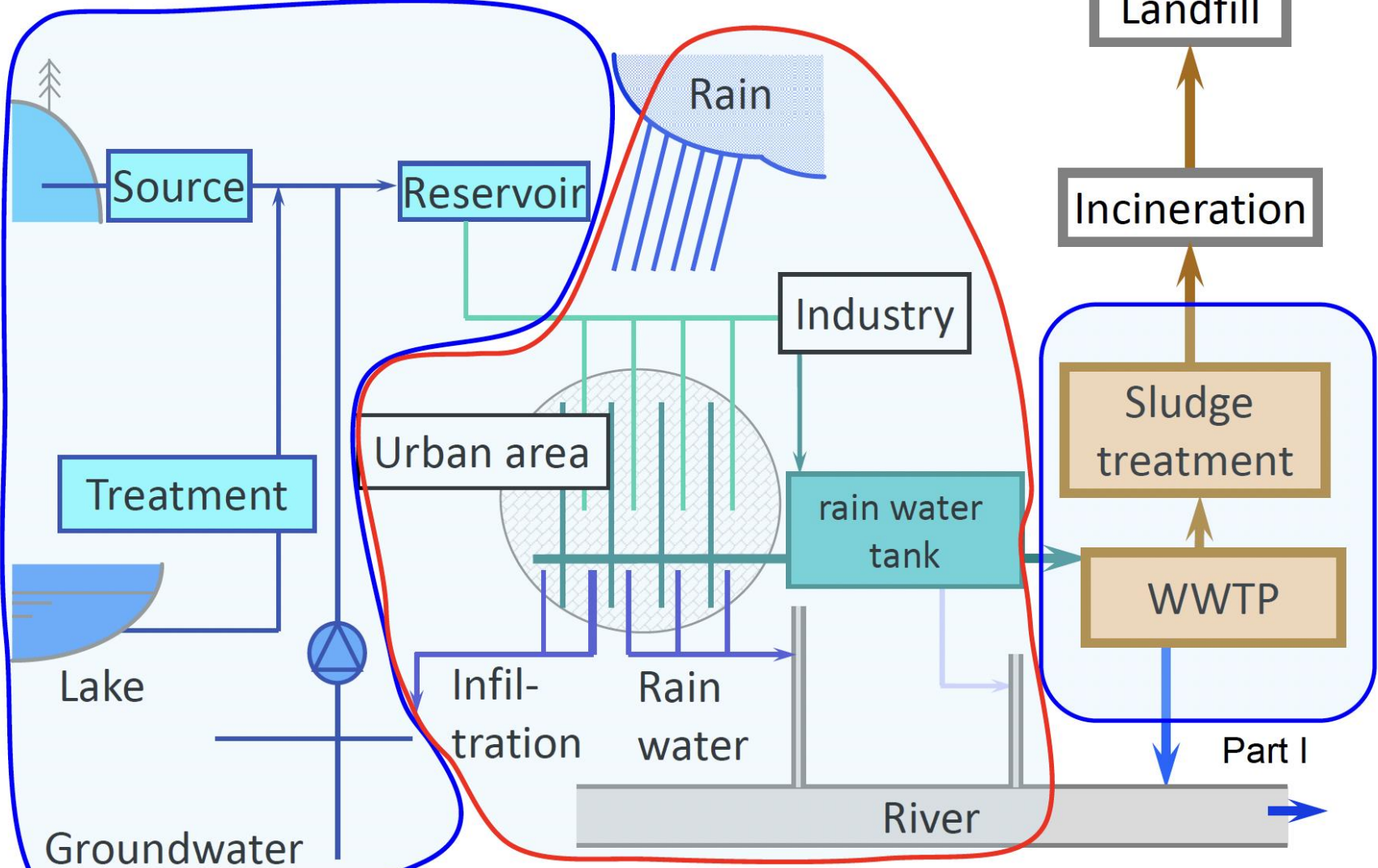

Content of the whole session

- Introduction to wastewater treatment
- Stoichiometry and bioenergetics
- Microbial kinetics
- Suspended growth systems
 - Process selection, design, and implementation (mass balances, design parameters)
 - Application
 - Process modeling
- Attached growth processes
- Biological nutrient removal
 - P and N
- Anaerobic treatment processes

Expected outcomes

- Basic understanding of unit processes used in the biological treatment of waste(water)
- Identify design parameters for aerobic and anaerobic treatment systems.
- Evaluate the performance of existing wastewater treatment plants and future designs.
- Differentiate between carbon, nitrogen, and phosphorus biological treatment systems
- Get familiarized with resource recovery strategies from waste(water).
- Apply course concepts to better understand and critique the scientific literature on wastewater treatment

This book is freely accessible online, it's also uploaded to Moodle. For each lecture, relevant Chapters will be indicated. **Lecture 1: Chapter 3, Chapter 2 as review**

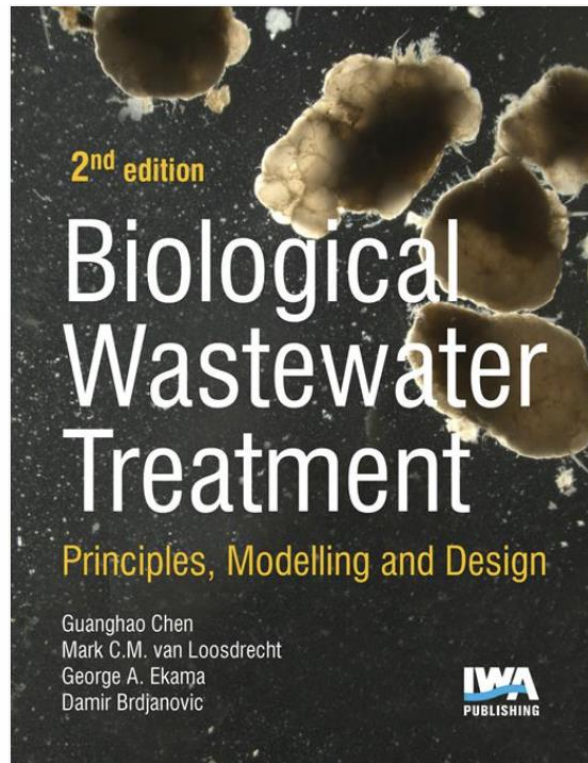

Biological Wastewater Treatment: Principles, Modelling and Design



Edited by

Guanhao Chen; Mark C.M. van Loosdrecht; George A. Ekama; Damir Brdjanovic

IWA Publishing

DOI: <https://doi.org/10.2166/9781789060362>

ISBN electronic: 9781789060362

Publication date: July 2023

Content of today:

Exercise hour starts from next week--- I will release homework 1 today, please take a week to try to solve the questions independently.

- Characterization of wastewater: simple analysis of estimating pollution, estimation of pollution load, and effluent quality
- Typical wastewater treatment systems or plants
- Review mass balance

Used water - wastewater



Domestic



Industrial



Agricultural

- Various constituents are added to water anthropogenically
 - Food, cleaning products, microbes, etc.

“Healthy water” is not without anything:

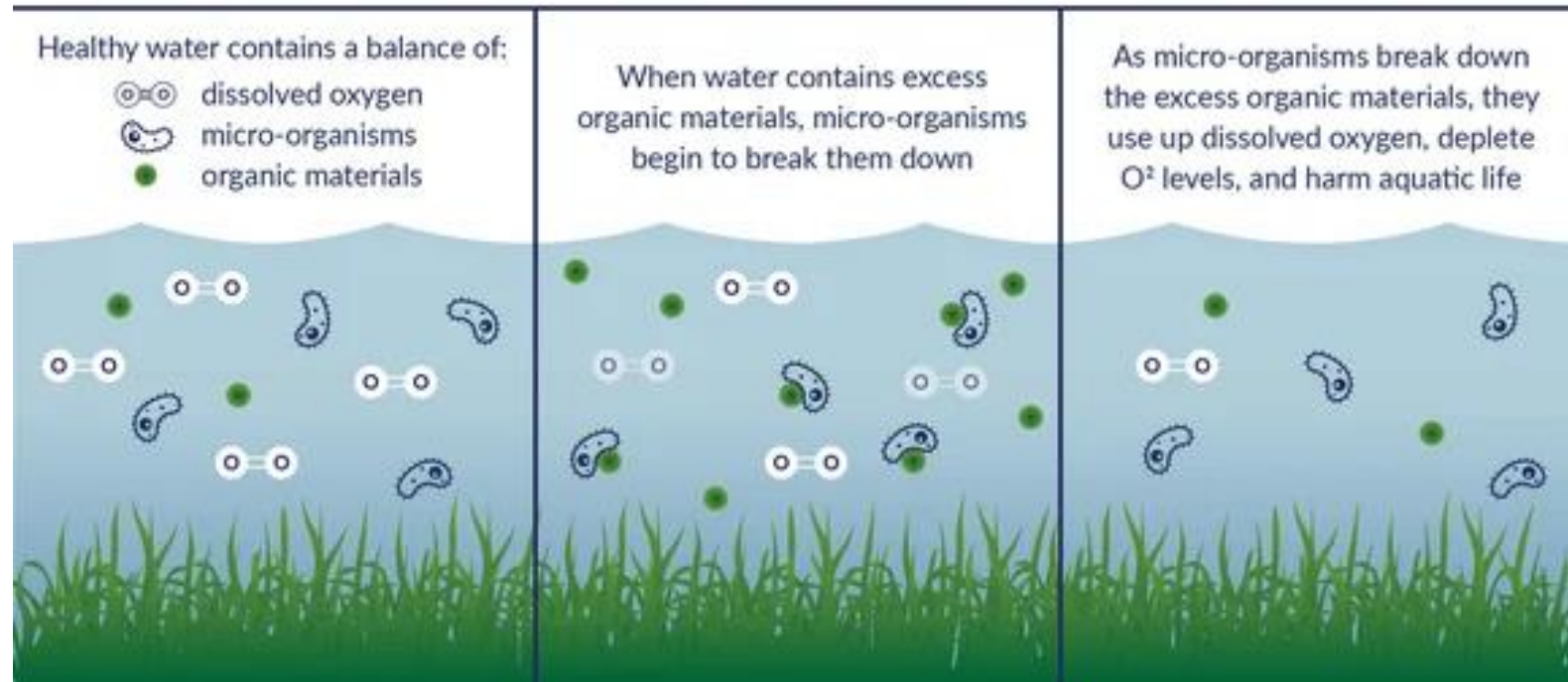

- The “nutrients” or containants can be detrimental to water bodies at high concentrations
 - Impact aquatic ecosystem and public health
- Wastewater treatment mitigates its impact



Pollutants of concerns in wastewater treatment

Suspended solids (SS)

- habitat for pathogens, clogging, oxygen demand for organic fraction

Organics

- primarily concerning oxygen demand (BOD/COD)

Nutrients (N & P)

- Allow excessive algal growth (accelerates eutrophication)

Pathogens

- viruses, bacteria, protozoa, helminths, etc.

Others

- Heavy metals, pesticides and agricultural chemicals, volatile organic compounds (VOCs), emerging contaminants

Classification of wastewater treatment methods

- Physical
- Chemical
- **Biological**

Wastewater Treatment Goals, where do we start?

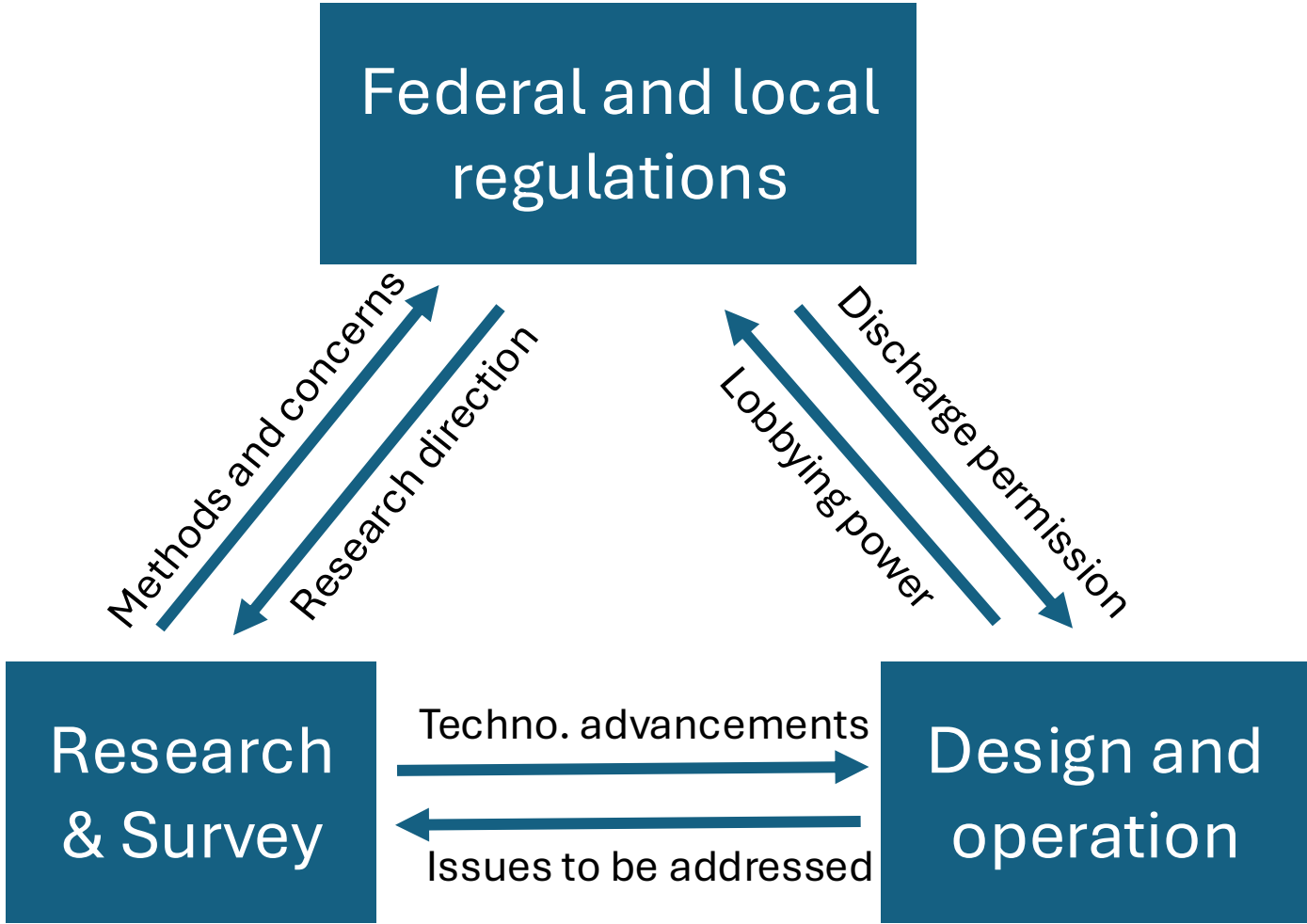

Contaminants removal to resource recovery

- Wastewater contains resources worthy of recovery
- Physical, chemical, biological processes
- Contaminants (wastewater treatment) → resources (resource recovery)
 - Organic carbon: energy and reducing power
 - Phosphorus: fertilizer
 - Water itself
 - Heat

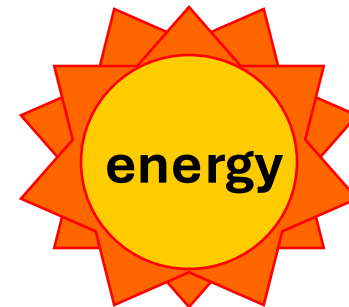

Wastewater composition by source

FIGURE 2

Nutrient distribution in urine and feces

Human excrement is the main source for nutrients in municipal wastewater.

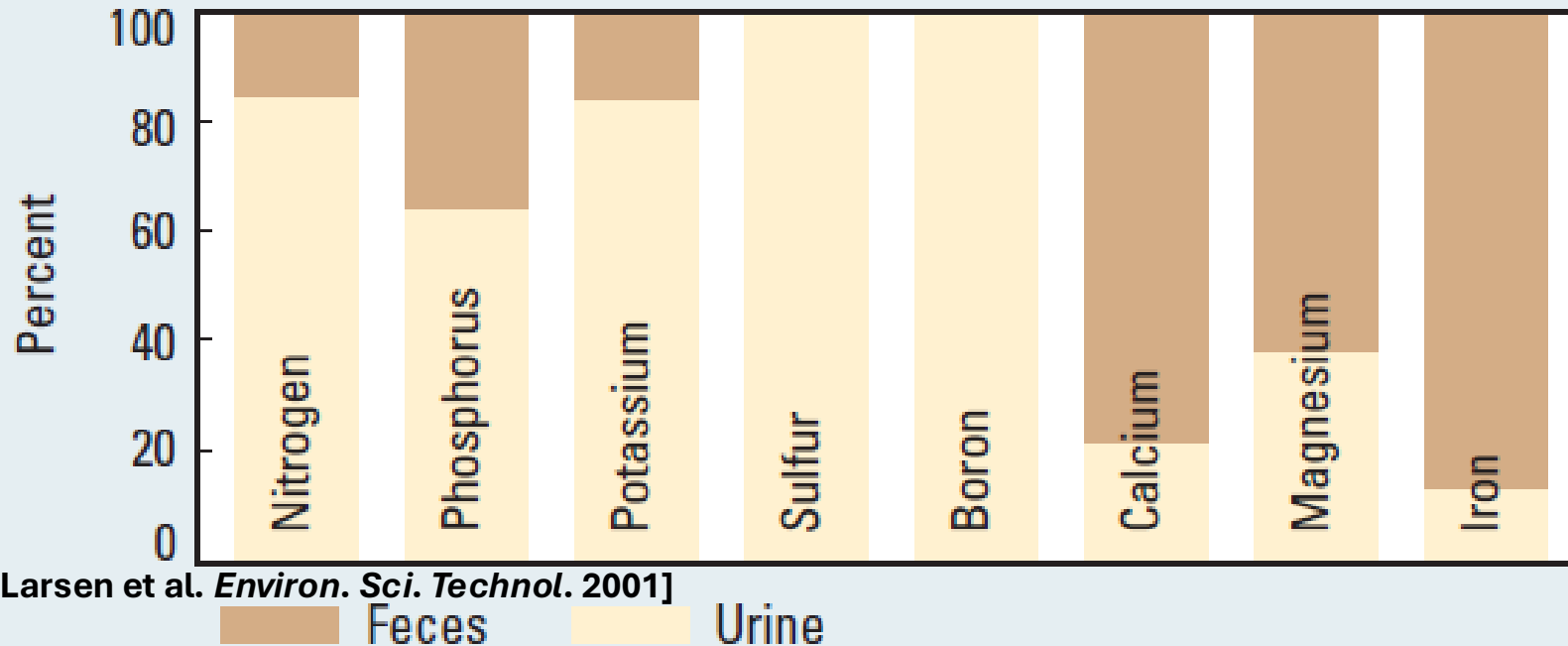

[Larsen et al. *Environ. Sci. Technol.* 2001]

Source: EAWAG.

Wastewater Characteristics

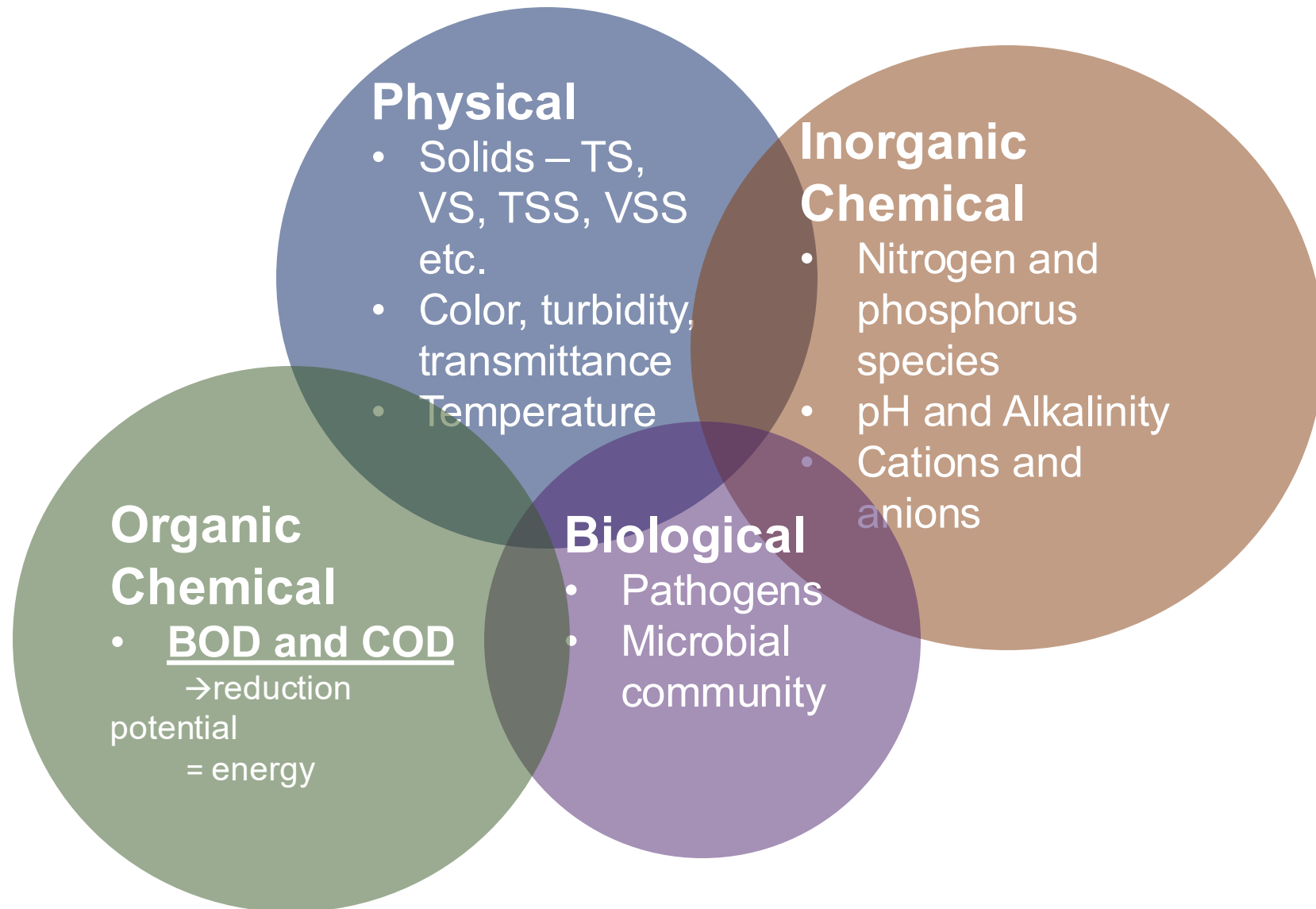

Wastewater Characteristics

Physical

- Solids – TS, VS, TSS, VSS etc.
- Color, turbidity, transmittance
- Temperature

- VS(S): organic solids; TS: organic solids + ash (inorganic), or $TS = \Sigma \text{ particulate matter} + \text{dissolved matter}$. TSS: suspended solids on filter
- Headworks and primary clarifiers remove most solids
→ solids in bioreactors are mostly biomass
- phosphorus species
- pH and Alkalinity
- Cations and anions

Organic Chemical

- BOD and COD
→ reduction potential = energy

Biological

- Pathogens
- Microbial community

For quick fact check of water quality tables, it's important to know which parameters should be always larger than other parameters:

Homework 1

• **TS (Total Solids)**: All solids. ***The word "Solid" here refers to to **all matter left behind after the water is evaporated at 103–105 °C** in a laboratory test. Not just chunks you can see...

• **TSS (Total Suspended Solids)**: Suspended portion of TS.

TS = TSS + TDS (Total Dissolved Solids)

• **VS (Volatile Solids)**: Organic (burnable) portion of TS, 550 °C

• **VSS (Volatile Suspended Solids)**: organic fraction of suspended solids,
• \approx suspended organic solids. **TS = VS + IS (sometime FS, fixed or inorganic solids)**

• **TOC (Total Organic Carbon)**: Organic **carbon** in dissolved + suspended.

• **TOC = dissolved organic carbon DOC + particulate organic carbon POC.**

$$TSS \geq VSS \geq POC$$

$$VS \geq TOC$$

Does the parameter include solids or only carbon?

$$VS \geq VSS$$

Wastewater Characteristics

N,P: needed for microbial growth, but may also cause eutrophication

pH, Alk: determines microbial growth condition

Inorganic Chemical

- Nitrogen and phosphorus species
- pH and Alkalinity
- Cations and anions

Organic Chemical

- BOD and COD
→ reduction potential = energy

Biological

- Pathogens
- Microbial community

Physical
• Solids = TS, VS, TSS, VSS etc.
• Color, turbidity
• Temperature

Nitrogen parameters

Total Kjeldahl nitrogen: TKN-N

global parameter

Kjeldahl nitrogen contains **organic nitrogen** (e.g. present in proteins) and **ammonium** ($\text{NH}_4^+\text{-N}$).

The **total Kjeldahl nitrogen** (TKN-N) is the nitrogen present in an unfiltered sample, **dissolved Kjeldahl nitrogen** the nitrogen in the filtrate. Ammonium is part of dissolved Kjeldahl nitrogen.

Ammonium: NH_4 et $\text{NH}_3\text{-N}$

Ammonia is composed of free ammonia (NH_3) and ammonium (NH_4^+). Ammonia is part of Kjeldahl nitrogen.

Nitrite: NO_2^- Nitrate: NO_3^-

Nitrite and Nitrate are oxidized nitrogen compounds which are almost absent in urban wastewater but are often produced in WWTP.

Wastewater Characteristics

- Pathogens: public health concerns when discharge or land applied
- Microbial community: active research area, may influent reactor performance

Physical

- Solids – TS, VS, TSS, VSS etc.

- Color, turbidity, transmittance
- Temperature

Inorganic

Chemical

- Nitrogen and phosphorus species
- pH and Alkalinity
- Cations and anions

Organic Chemical

- BOD and COD
→ reduction potential
= energy

Biological

- Pathogens
- Microbial community

Wastewater Characteristics

- Oxygen demand: measures reducing power, an indicator for biological processes
- COD – O_2 eq. of $Cr_2O_7^{2-}$ needed for full oxidation of organic carbon chemically
- BOD – O_2 needed for biological oxidation
- ThOD – Theoretical oxygen demand, both C and N, not commonly used

TSS, VSS etc.

- Color, turbidity, transmittance
- Temperature

Chemical

- Nitrogen and phosphorus species
- pH and Alkalinity
- Cations and anions

Organic Chemical

- BOD and COD
→ reduction potential = energy

Biological

- Pathogens
- Microbial community

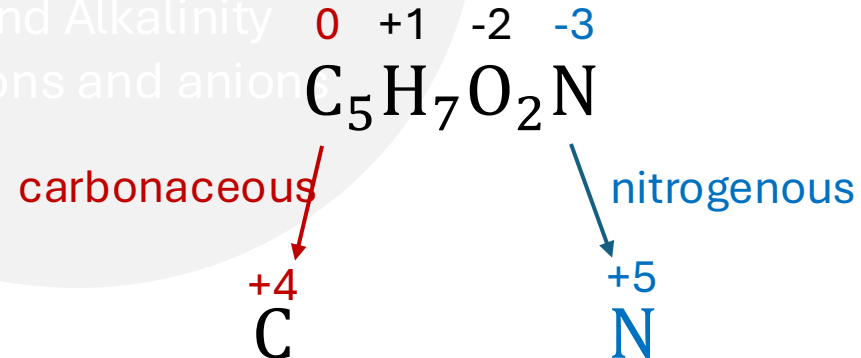

Organic Carbon

- Organic carbon indicates how much carbon is present in organic matter.

Example: Glucose $C_6H_{12}O_6$

180 g Glucose ($6 \times 12 + 12 \times 1 + 6 \times 16 = 180$) have a

DOC of 72 g ($6 \times 12 = 72$)

Biological Oxygen Demand (BOD)

- Most popular measure of oxygen demand of wastes
- BOD measures O_2 needed for microbes to degrade organic matter:
- Regulation of discharges to natural waters
 - (e.g., 30 mg BOD₅/L for secondary treatment)

BOD Assessment (BOD₅): Collect a wastewater sample, dilute with appropriate dilution water (nutrient-rich or natural), and add a microbial seed if needed. Incubate the sample in the dark at 20 °C for 5 days, measuring dissolved oxygen (DO) depletion by microorganisms. Ensure a minimum 2 mg/L DO drop and final DO above 0.5–2 mg/L for valid results.

There are other different types of BOD.

Carbonaceous and nitrogenous biological oxygen demand (CBOD and NBOD)

- The oxidation of nitrogen compounds also uses significant O_2 .
- In aerobic environments, bacteria convert ammonia NH_3 to nitrate NO_3^- , in a process known as Nitrification.
- CBOD can be measured by inhibiting nitrifiers.

$$NBOD = BOD - CBOD$$

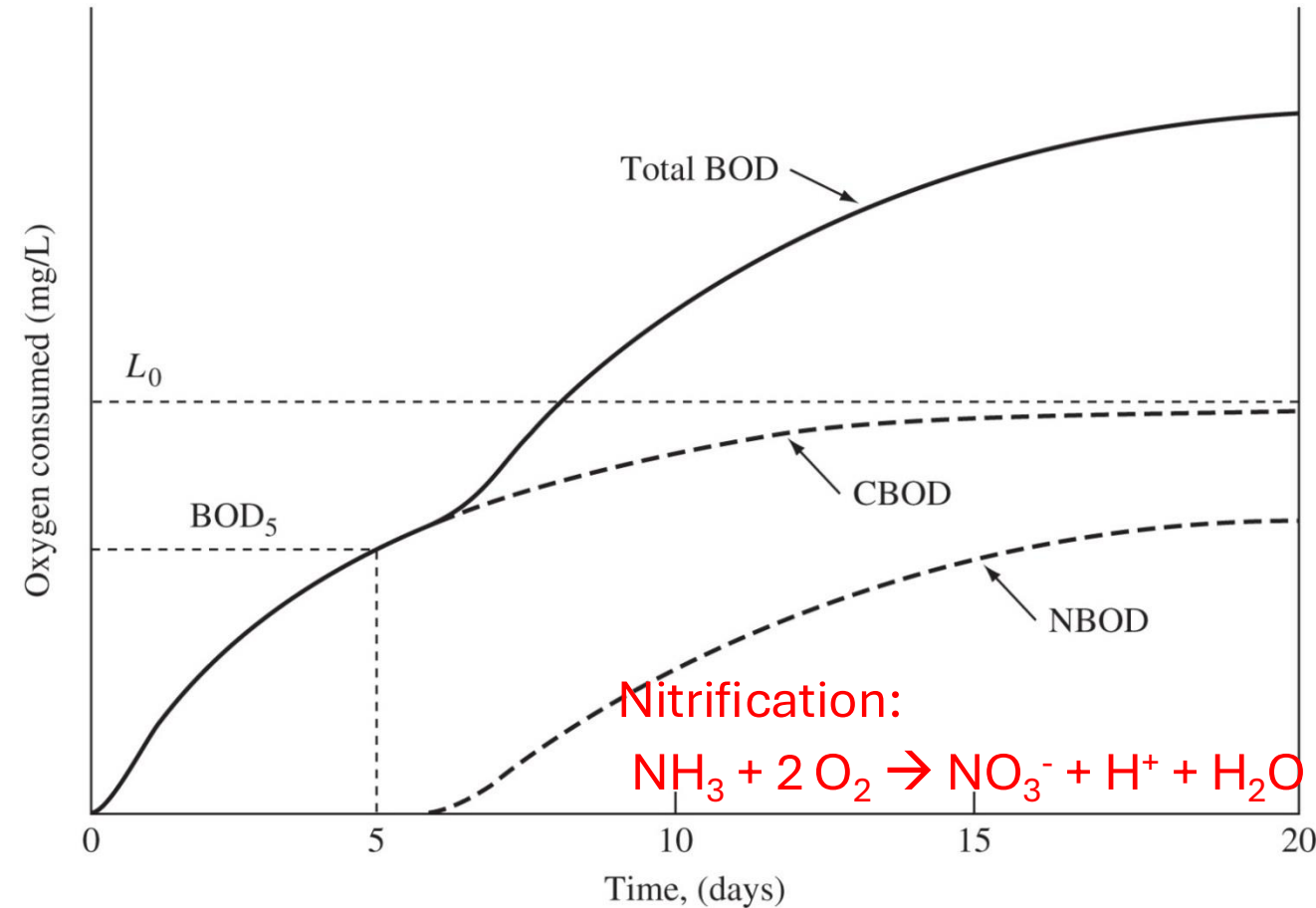

Figure: 05-13

Chemical Oxygen Demand (COD)

- COD test is simple and easy to perform, can be done in ~3 hours.
- COD measures all chemicals in the water that can be oxidized by a chemical oxidant, like potassium dichromate ($K_2Cr_2O_7$) or manganese III oxidant (HACH).



Chemical Oxygen Demand (COD)

Homework 1

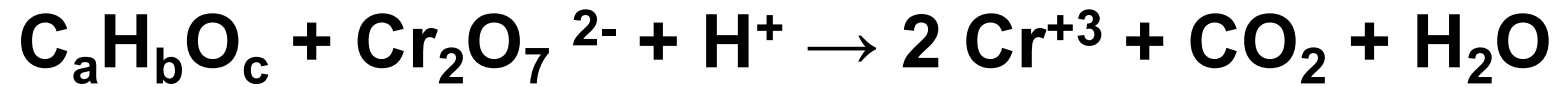

NOTE - This is an oxidation-reduction reaction:

_____ is oxidized

_____ is reduced

Theoretical oxygen demand (ThOD) can be determined for any organic compound by balancing the above equation. Ideally, ThOD = COD.

Theoretical Oxygen Demand (ThOD)

Homework 1

Stoichiometric approach

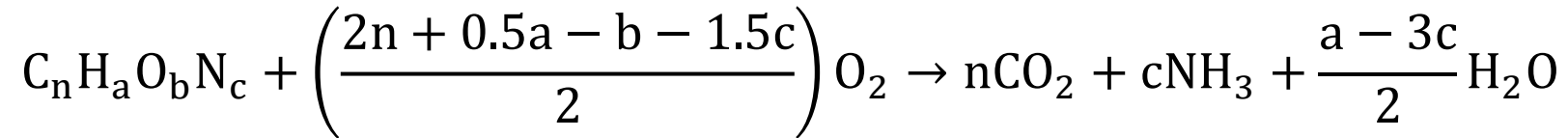

Equation 5.2 (EB)

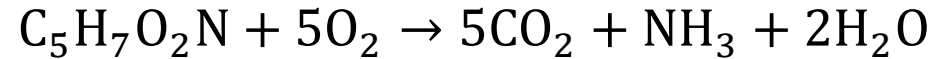

$$\frac{5 \text{ mol } O_2}{\text{mol } C_5H_7O_2N} \times \frac{32 \text{ g } O_2}{\text{mol } O_2} \times \frac{1 \text{ mol } C_5H_7O_2N}{113 \text{ g } C_5H_7O_2N} = 1.41 \frac{\text{g } O_2}{\text{g } C_5H_7O_2N}$$

See Table 3.1 in GDLF for a list of ThOD of common compounds

Example 2

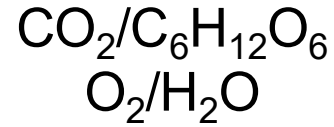

Balance non-O, H elements: $\text{C}_6\text{H}_{12}\text{O}_6 \rightarrow 6\text{CO}_2$

How many electrons are involved in the oxidation of glucose:



Achieve an ionic balance with H^+ : $\text{C}_6\text{H}_{12}\text{O}_6 \rightarrow 6\text{CO}_2 + 24 e^- + 24\text{H}^+$

Balance H and O by adding H_2O molecules: $\text{C}_6\text{H}_{12}\text{O}_6 + 6\text{H}_2\text{O} \rightarrow 6\text{CO}_2 + 24\text{H}^+ + 24e^-$



Overall: $\text{C}_6\text{H}_{12}\text{O}_6 + 6\text{H}_2\text{O} + 6\text{O}_2 + 24\text{H}^+ + 24e^- \rightarrow 6\text{CO}_2 + 24\text{H}^+ + 24e^- + 12\text{H}_2\text{O}$

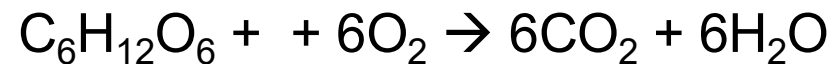

Total Organic Carbon (TOC)

- Oxidize organics thermally or chemically and detect formation of CO₂



Choosing among TOC, COD, and BOD

- TOC

- Sensitive: $50 \mu\text{g/L}$ Measurement takes min
- TOC often used for **natural waters and drinking waters**.
- Measure sample with TOC analyzer or calculate TOC of specific compound.
- Results reported as **mass C/L**.

- COD

- Use chemical redox rxn to measure oxygen demand. Takes h
- COD often used for **higher strength samples (WW)**.
- Even biologically recalcitrant compounds can be oxidized ($\text{BOD} < \text{COD}$).
- Measure sample with COD kit or calculate ThOD of specific compound.
- Results reported as **mass O_2/L** .

- BOD

- Set up biological experiments to measure BOD of unknown sample. Takes days
- BOD often used for **higher strength samples (WW)**.
- Results reported as **mass O_2/L** .

Wastewater Treatment Goals

| Constituent | Municipal WW influent | Effluent Goal |
|------------------|---|---------------|
| BOD ₅ | 100-300 mg/L | < 20 mg/L |
| TSS | 100-350 mg/L | < 20 mg/L |
| TKN | 30 mg N/L | < 3 mgN/L |
| P | 10 mg P/L | < 0.3 mgP/L |
| Fecal coliforms | 10 ⁴ -10 ⁵ cells/mL | 2-4 cells/mL |
| pH | | 6-9 |

These vary depending on receiving water

Designing WWT process needs to take into account of the daily and seasonal variation.

Daily wastewater flow

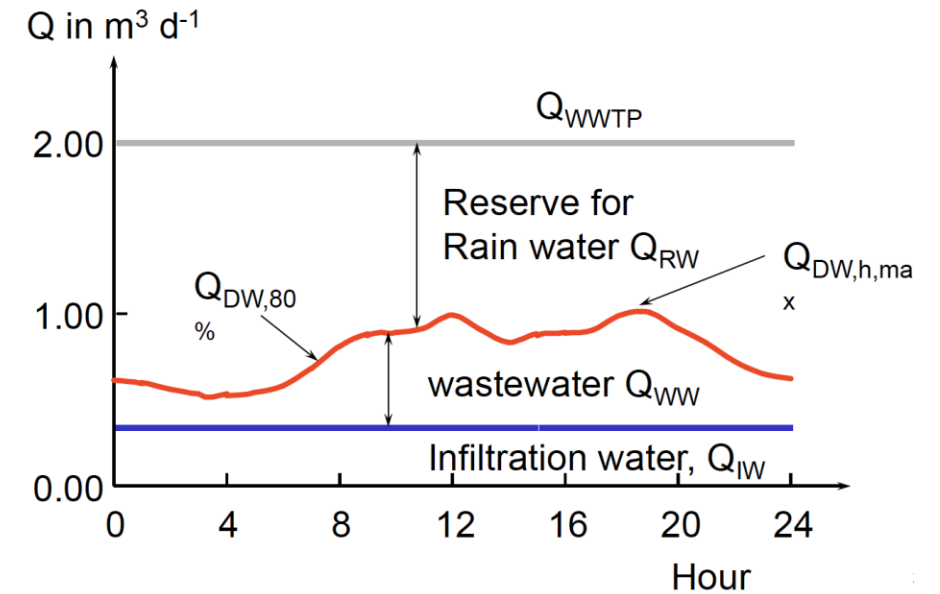

NH₄⁺ load during the day

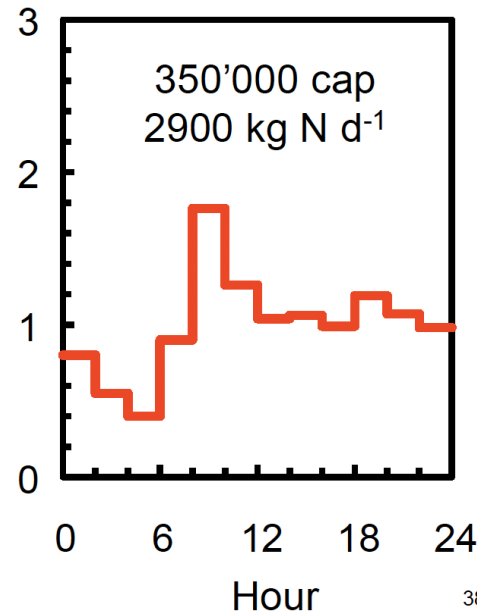
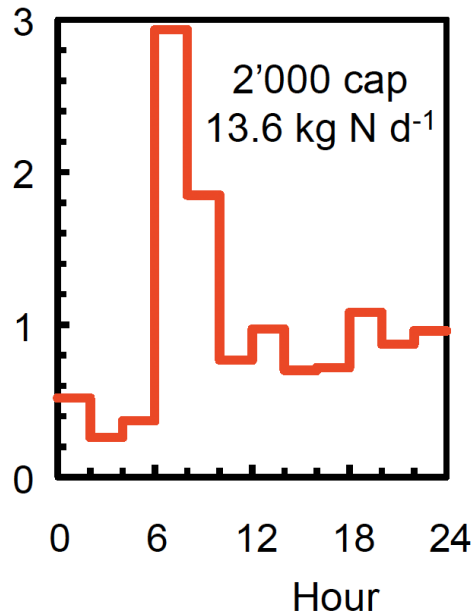

Wastewater flow during the year

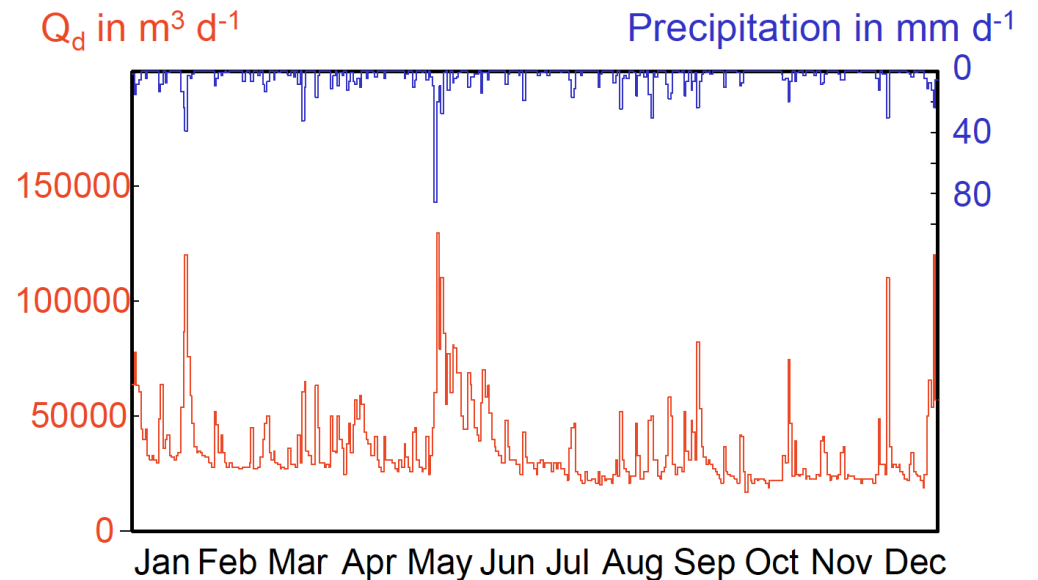

BREAK

Typical wastewater treatment train

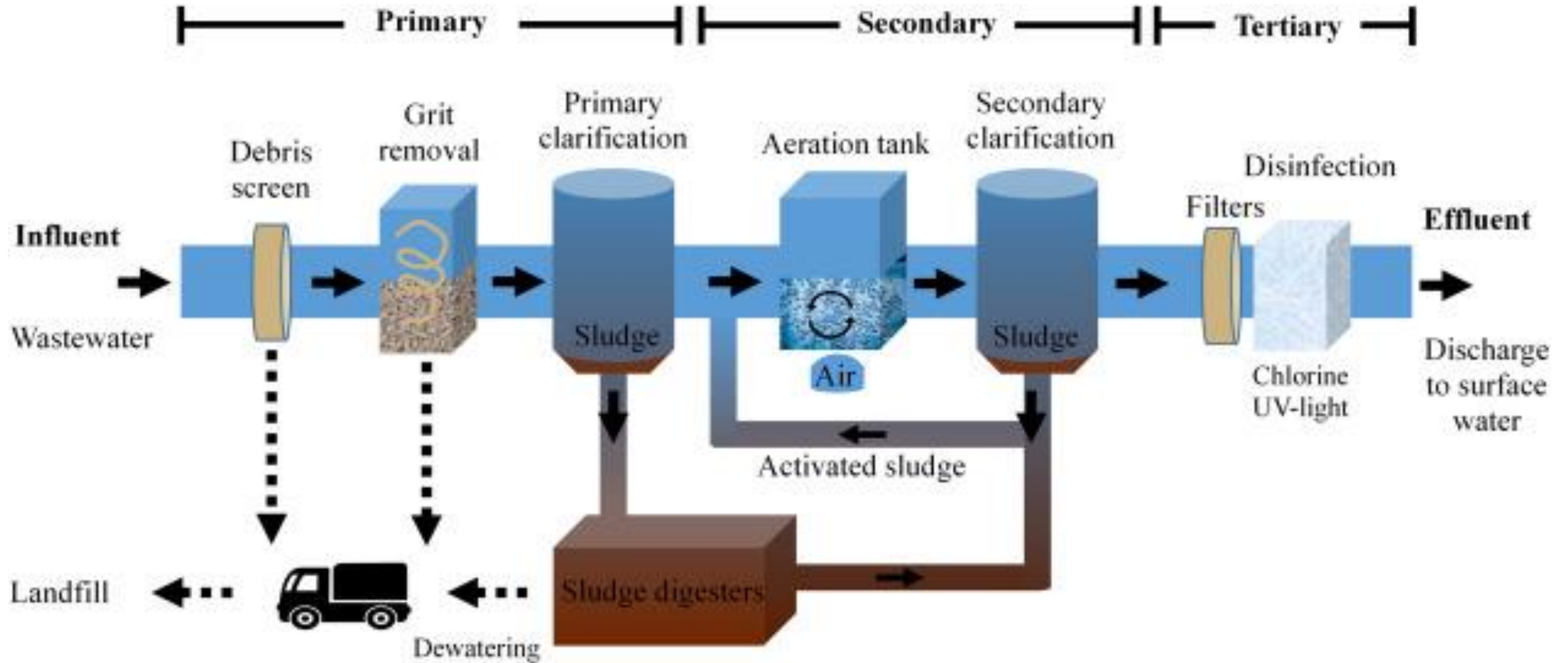

Let's Take a Tour

https://www.youtube.com/watch?v=A2FmNrEmowE&ab_channel=WaterEnvironmentFederation

- Note some difference:
Switzerland **banned landfilling of untreated organic waste, including sewage sludge, in 2000** to protect groundwater and reduce methane emissions.
- Land application of sewage sludge on farmland was also **phased out by 2006**, due to concerns about heavy metals, micro-pollutants, and pharmaceuticals.
- Today, **nearly all sludge is incinerated** in specialized sludge incinerators or co-incinerated in municipal solid waste or cement plants.
- The **ash is collected** because it contains **phosphorus**, which Switzerland now requires to be recovered (by law since 2016, with full implementation by 2026).

The wastewater treatment plants in Switzerland

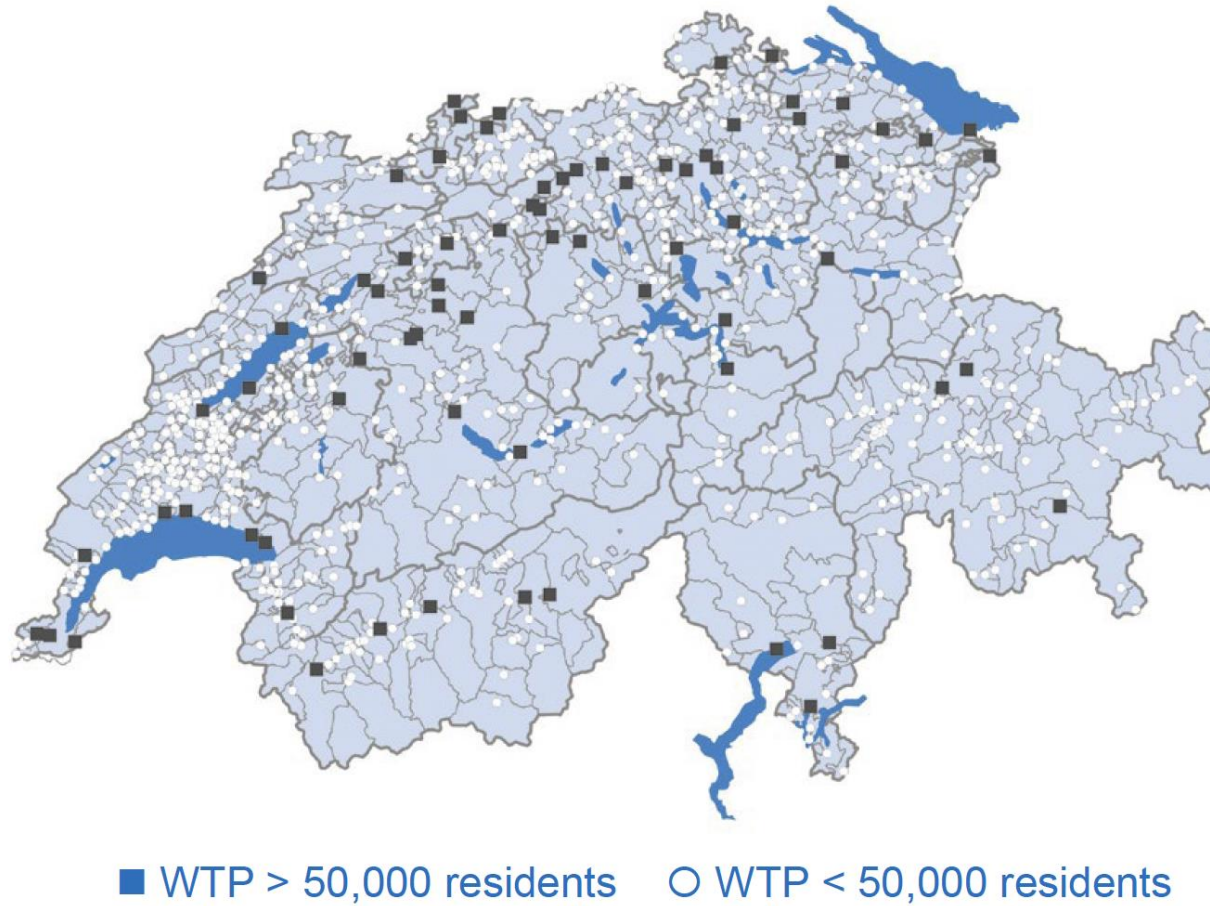

Wastewater treatment levels

- Primary treatment – physical treatment (screening, sedimentation)
 - Removes ~ 35% BOD and ~ 60% suspended solids
- Secondary treatment – biological (microbial) oxidation of wastes
 - Required by the Clean Water Act of 1972
 - Must remove ~85-95% BOD and TSS
 - With disinfection, reduces fecal coliforms down to 2-4 cells/ml (99.9%) reduction
- Advanced (Tertiary) Treatment
 - Removes nutrients (N,P) and/or particular pollutant
- Sludge Treatment and Energy Recovery

Classification of Biological Operations

- Various biochemical transformations involved
- Different biochemical environment
 - Aerobic, anoxic, and anaerobic
 - Diverse microbial communities
- Different bioreactor configurations available

Biochemical Environment- we will revisit this in later lectures

----- Without Oxygen -----

| Class → | <u>Aerobic</u> | <u>Anoxic</u> | <u>Anaerobic</u> |
|---------------------|---|-----------------|-------------------------------|
| Metabolic Process → | <div style="border: 2px solid blue; padding: 5px; display: inline-block;">Respiration</div> Producing sludge | Denitrification | Fermentation/Methanogenesis |
| Electron Acceptor → | Oxygen | Nitrate | Organic carbon/Carbon dioxide |

Aerobic/Anoxic Operations - we will revisit this in later lectures

| Reactor Environment | Achievement |
|----------------------------|----------------------------------|
| Aerobic | C removal, N conversion possible |
| Anoxic/Aerobic | C and N removal |
| Anaerobic/Aerobic | C and P removal |
| Anaerobic/Anoxic/Aerobic | C, N and P removal |

Reactor configurations

1. Suspended growth

- Continuous stirred tank reactor (CSTR)
- Sequencing batch reactor (SBR)
- Plug-flow reactor (PFR)

2. Attached growth

- Packed towers
- Rotating discs (RDR or RBC)
- Fluidized beds (FBBR or MBBR)

3. Combined/Integrated Systems

- Integrated fixed film activated sludge system (IFAS)

Suspended growth reactor

- Microorganisms suspended in the reactor /liquid under treatment
 - +Efficient substrate uptake
 - Needs mixing → energy input
 - Need to retain and recycle biomass (microorganisms) by separating them from liquid → extra structure

Attached growth reactor

- Microorganisms grows as biofilm on a surface
 - +Biomass easily retained in the reactor
 - +Biofilm protects microorganisms from toxic substances
 - Substrate and O_2 needs to diffuse through biofilm to reach biomass
 - Biofilm sloughing - Still needs sedimentation for effluent quality

Continuous stir-tank reactor (CSTR)

- Most common reactor configuration
- Complete mixing \rightarrow bulk solution = effluent
 - +handle peak loads and dilute toxic substances
 - large vol. high aeration costs
 - biomass instabilities like sludge bulking
 - limited operational flexibility

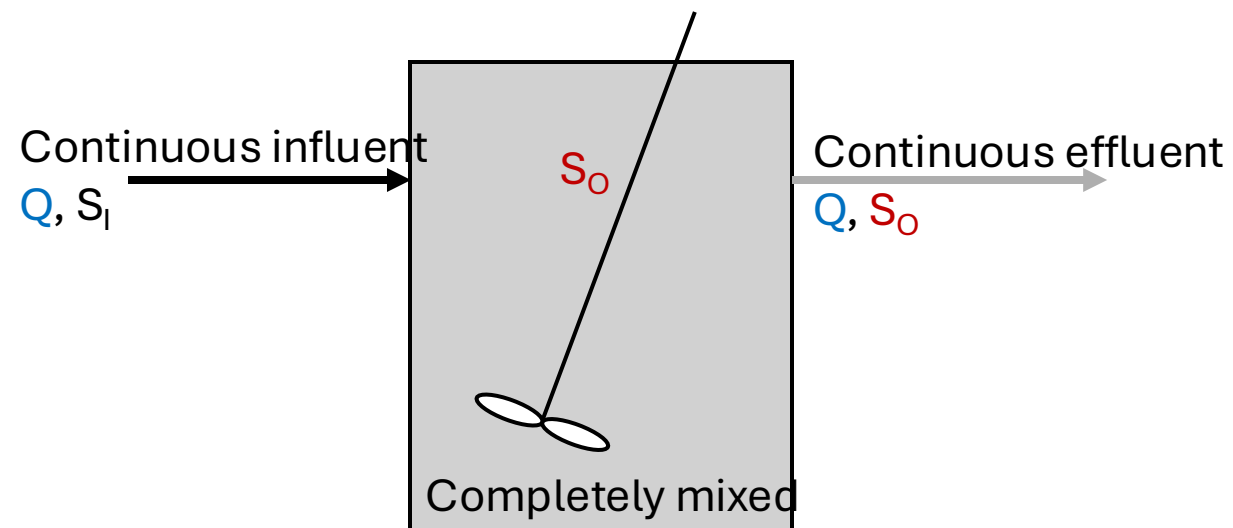

Sequencing Batch reactor (SBR)

- Feed → react → empty
 - +Single tank for reaction and settling
 - Also does not dilute toxic substances in the influent
 - Initial decant may contain high solids – need to recycle

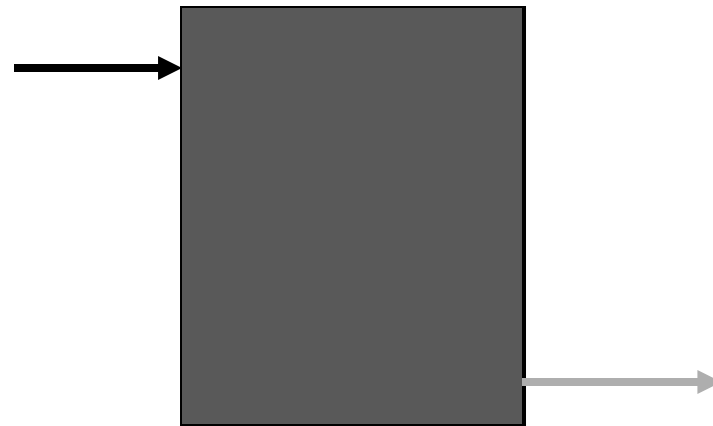

Plug flow reactor (PFR)

- Substrate degrades along the reactor
 - +More efficient than CSTR – smaller reactor vol.
 - more susceptible to loading spikes and toxic substances
 - high O_2 demand at the inlet
 - more complex construction

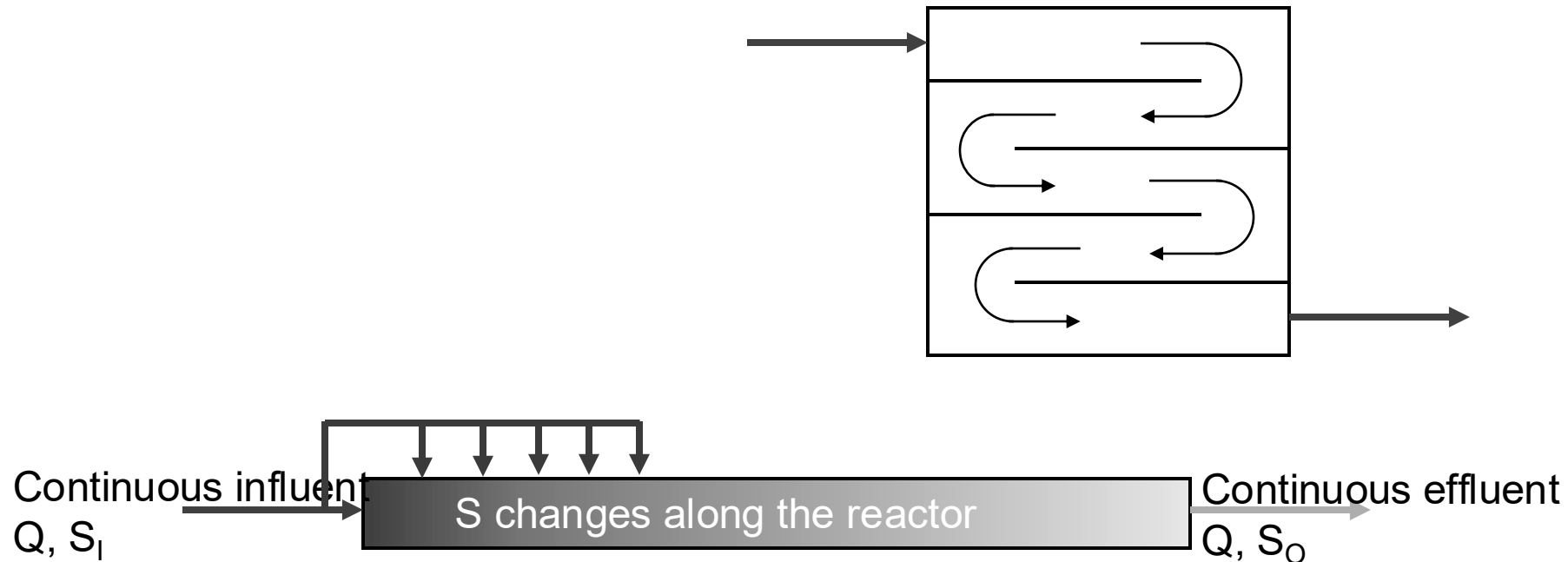

Packed tower/Trickling filter

- Wastewater sprayed on the packing material, flows through the biofilms
 - +Mechanically simple
 - +Not energy intensive
 - Hard to model/design

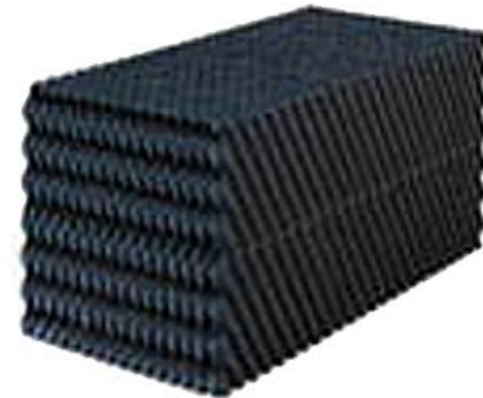

Rotating disc reactor

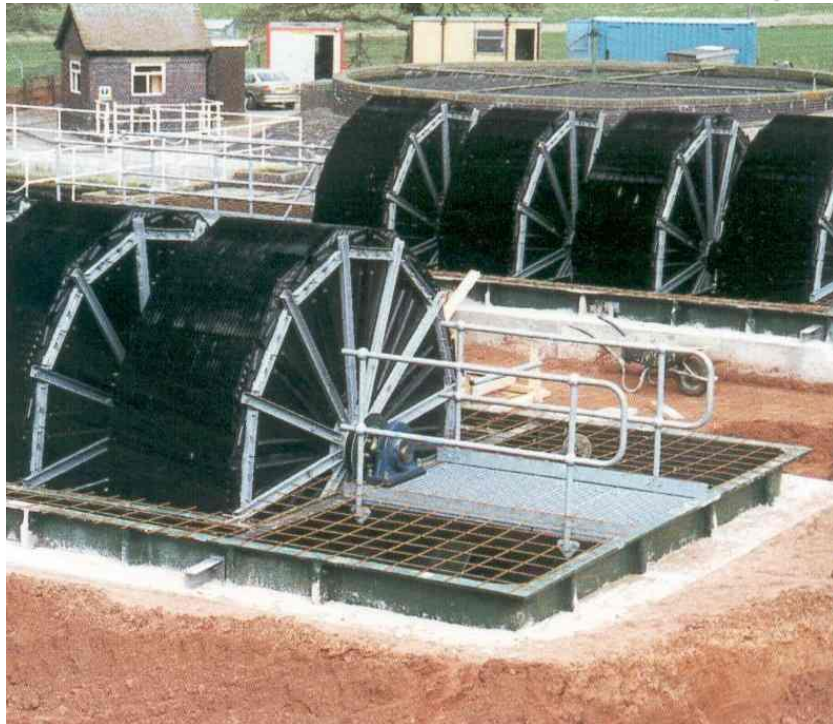
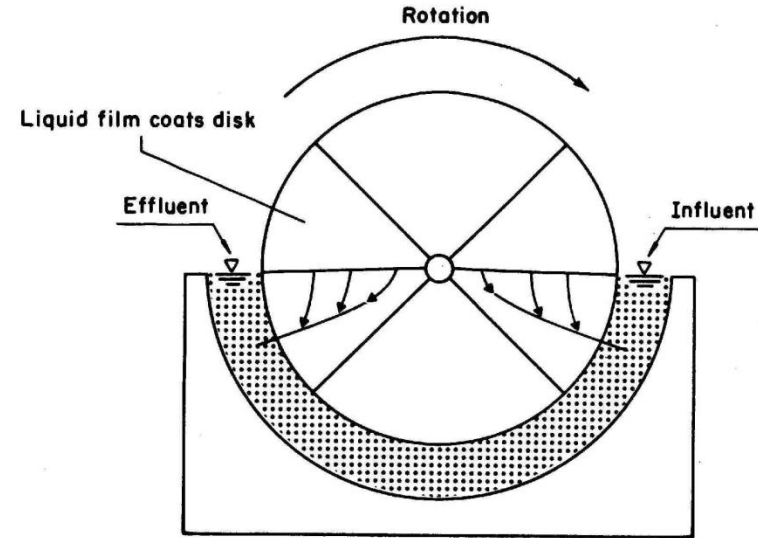
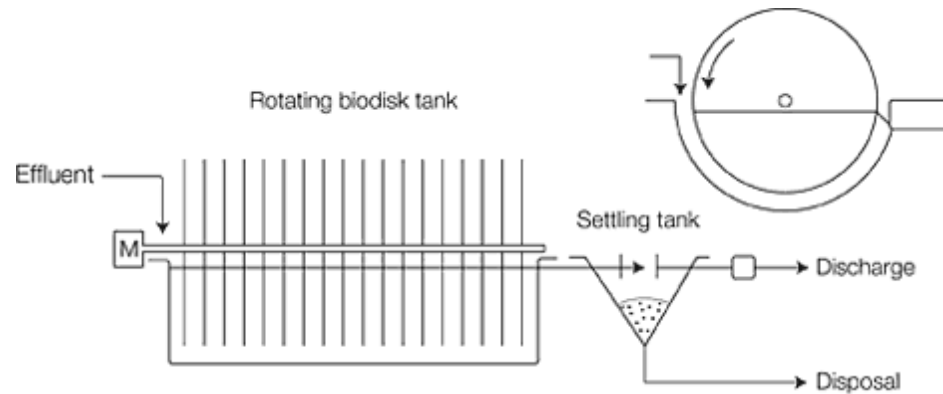

Fluidized bed bio-reactor

- Similar to upflow sludge blanket and granular sludge
 - +High biomass concentration - efficient
 - Precise hydraulic control
 - Loss of carrier material

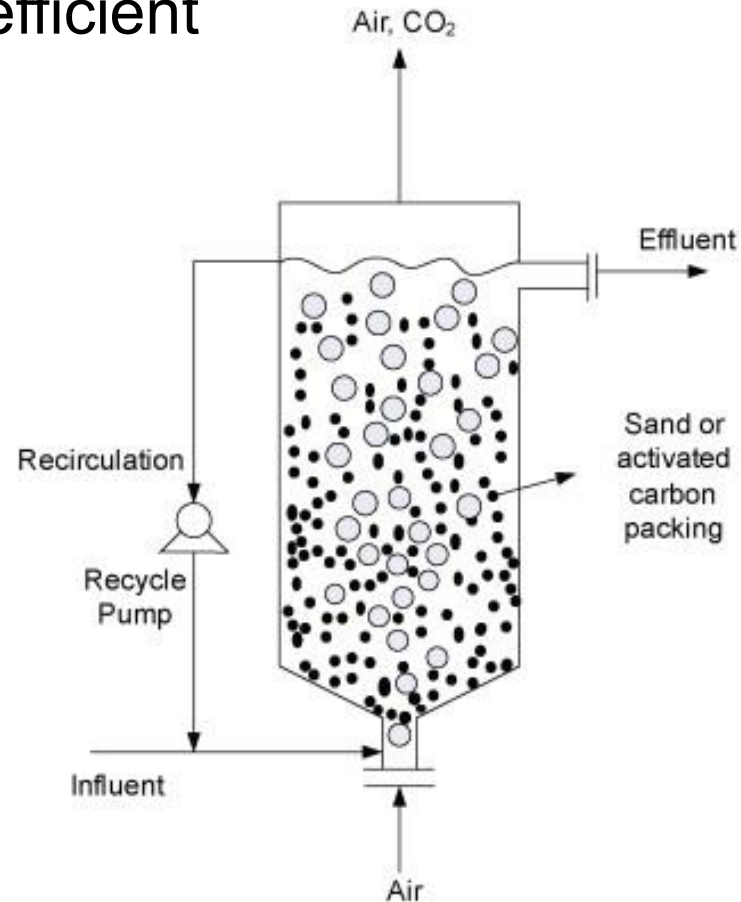

Review: mass balance. Pay attention to the units.

The concept of load and loading rate

$$\text{Accumulation} = \text{Input} - \text{Output} + \text{reaction}$$

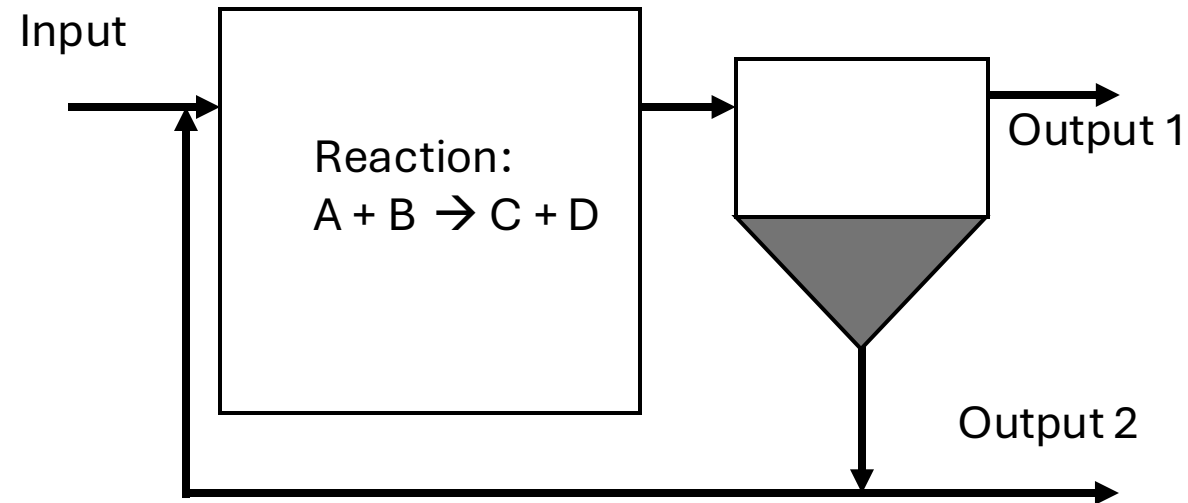

- **Load:**

- Definition: Quantity of pollutant (mass) that arrives at WWTP per unit of time
- Unit: kg d^{-1}
- Calculation: $\text{load} = \text{population} \times \text{per capita load}$
 $\text{load} = \text{concentration} \times \text{flow}$

- **Loading rate:**

- Definition: Quantity of pollutant (mass) that can be loaded to a treatment unit per unit of time, and either per volume or mass of biomass (volume or mass loading)
- Unit: $\text{kg}_{\text{COD}} \text{ m}^{-3} \text{ d}^{-1} / \text{kg}_{\text{COD}} \text{ kg}_{\text{VSS}}^{-1} \text{ d}^{-1}$

Step 1: Volume/flow balance

HOMEWORK 1

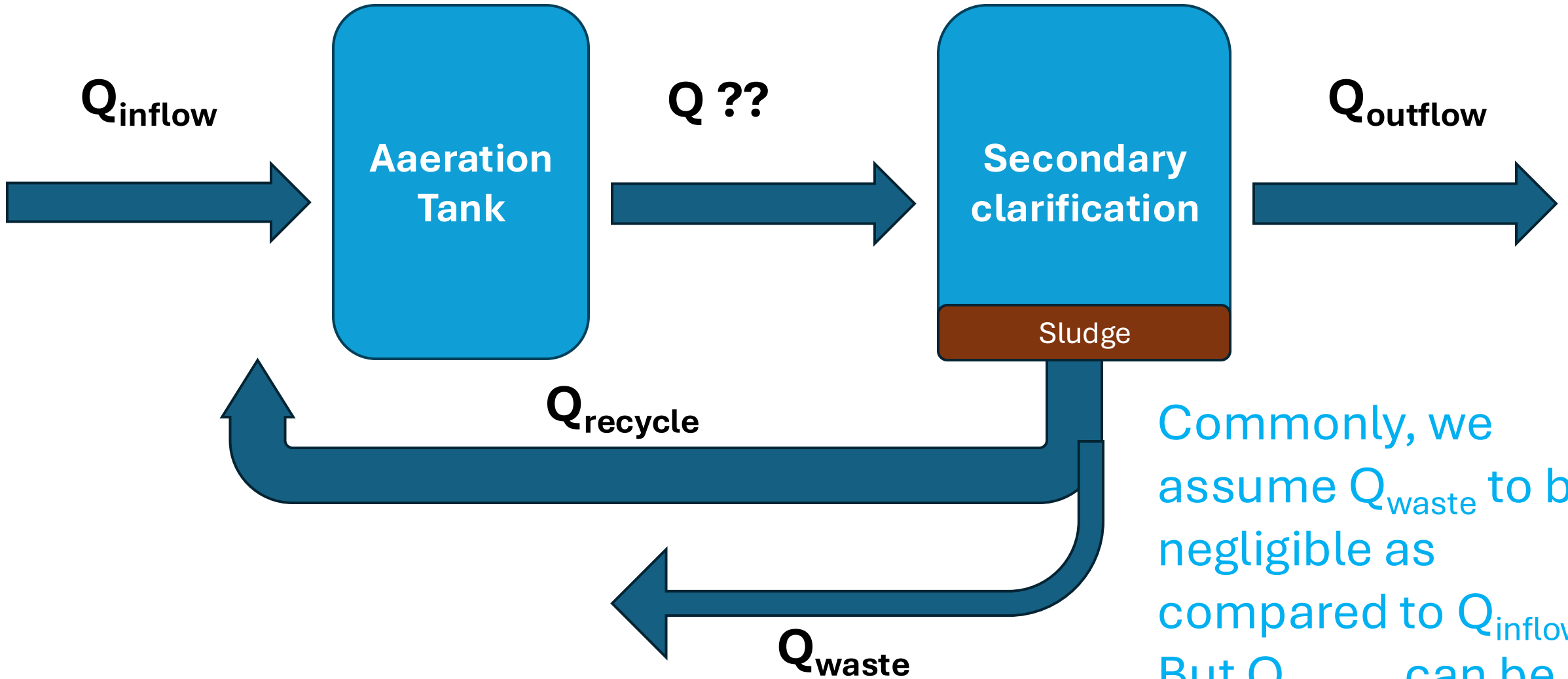

Commonly, we assume Q_{waste} to be negligible as compared to Q_{inflow} . But $Q_{recycle}$ can be very close to Q_{inflow} .

Step 2: Mass balance: the production and recycling of sludge X

HOMWORK 1

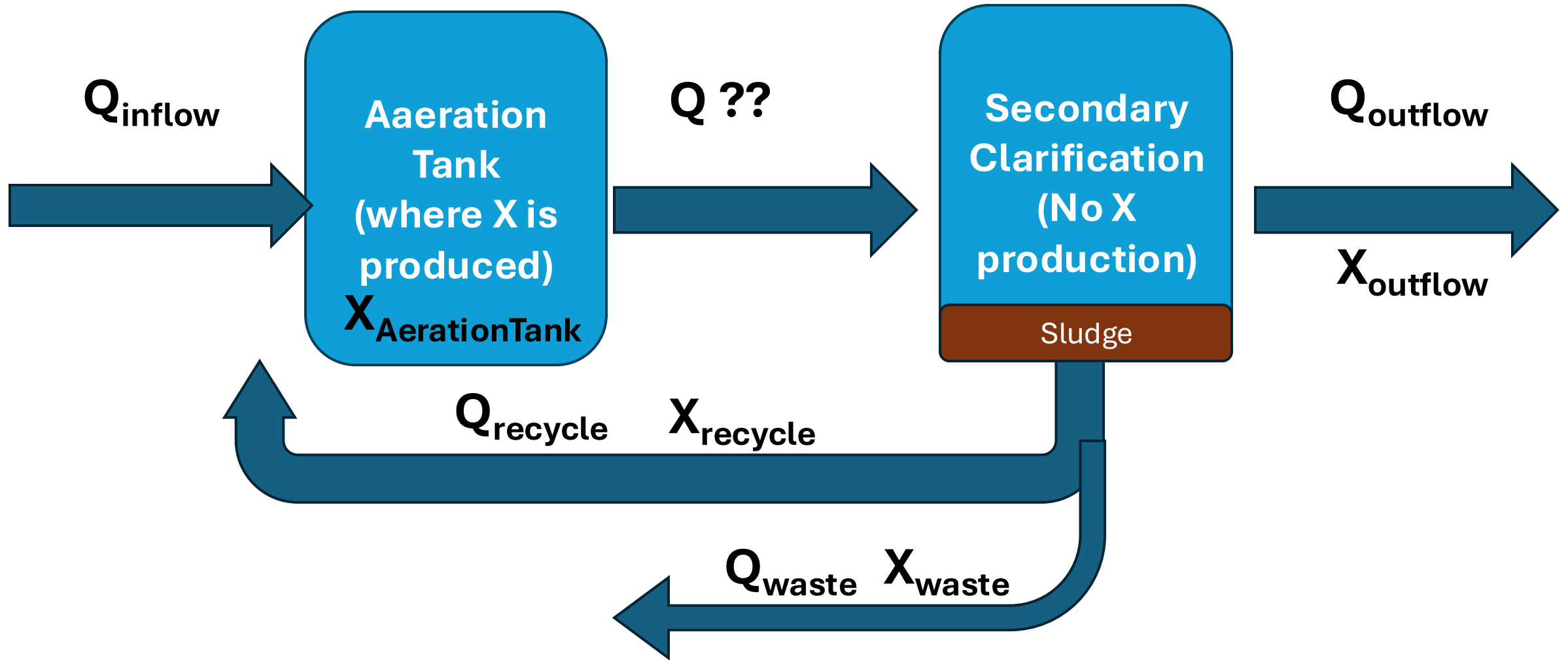

Mass balance for the whole system?

Mass balance for the Secondary clarification?

Goal of learning today

- Familiarize with the different parameters of WW, get a “common” sense
- Remember a typical wastewater treatment systems
- Review and calculate mass balance!