

Exercises on Energy consumption of IOT nodes

- Nodes A, B and C in Figure 1 periodically collect and send temperature samples to the remote sink. The transmission phase is managed through a dynamic clustering approach which works as follows: two nodes send their samples to the clusterhead which then takes the average out of all the samples (two received and one obtained locally) and sends a single packet to the SINK. The clusterhead role is assigned in a round robin fashion starting from node A (node A, then B, then C, then A, etc.) (when clusterhead is C, B sends its message directly to C, and viceversa, not through A). Find the network lifetime (time to first death) with the following parameter set:

- Energy required to operate TX/RX circuitry $E_c = 6[\mu J/\text{packet}]$
- Energy required to support sufficient transmission output power $E_{tx}(d) = k \times d^2 [nJ/\text{packet}]$, with $k = 120[\frac{nJ}{\text{packet}}/m^2]$
- Energy for taking the average of 3 samples $E_p = 4[\mu J]$
- Initial energy budget $E_b = 122[\mu J]$ for all the three nodes.

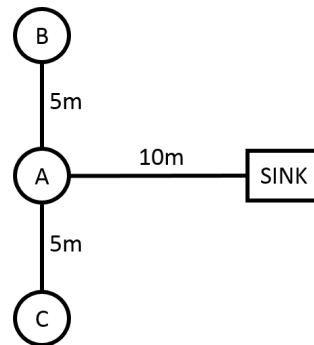

Figure 1

- The personal area network in Figure 2 is used to gather periodical information on the average temperature of a given area. N nodes are geared with temperature sensors. Consider the following scenarios:
 - The sensors periodically report their measurements to the PAN Coordinator which then relays each report to the information sink which performs the average operation.
 - The sensors periodically report their measurements to the PAN Coordinator which performs the average operation and then sends one averaged sample to the information sink.

Assuming that:

- Sensors are $d=5$ meters away from the PAN Coordinator, and the PAN Coordinator is $D=10$ meters away from the sink
- The packets containing the temperature samples and the averaged temperature are 127 [byte]
- Energy required to operate TX/RX circuitry $E_c = 50 [nJ/\text{bit}]$
- The energy required to support sufficient transmission output power $E_{tx}(d) = k \times d^2 [nJ/\text{bit}]$, with $k = 1[\frac{nJ}{\text{bit}}/m^2]$
- The energy required to perform the average operation is $E_p = 4[\mu J]$ for each temperature measure to be averaged.

- The energy consumption for the averaging operation performed at the information sink is negligible.

Write the energy consumption to get one averaged temperature value at the sink when $N=4$ in the two aforementioned cases

Under the given parameters, is there any value of N beyond which performing the averaging operation at the PAN Coordinator is less energy-efficient than at the sink? If so, find out this value.

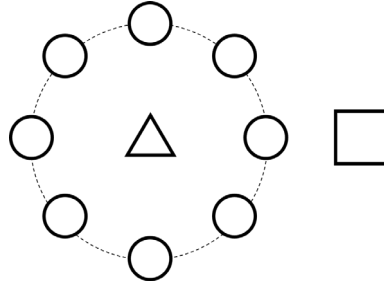

Figure 2

3. A sensor node generates a stream of 3 packets at a fixed rate of one packet every x [s]. The packets must be delivered to a sink node for further processing. The nominal data rate is $R=250$ [kb/s] and the packets are of $L=1000$ [bit]. The operating power level for TX circuitry is $P_{tx} = 100$ [mW]. The power emitted to the antenna is $P_0 = 100$ [mW]. The power consumed while in idle and sleep states are $P_{idle} = 60$ [mW] and $P_{sleep} = 10$ [mW], respectively. In case the sensor goes to sleep, it needs a wake-up time of $T_w = 500$ [μ s]. Write the energy consumption for transmitting the 3 packets in the 2 cases where (1) the sensor node goes to sleep after each transmission and wakes up when the following packet is ready, (2) the sensor node is always active (assume that in both cases the sensor node is asleep at the very beginning of the operations). Is there any value of x for which case (2) is more energy efficient than case (1)?
4. A visual sensor network is composed of a camera node and a plain mote (see Figure 3). The camera node acquires an image of $I=10$ [MByte] which needs to be processed. The camera node sends a fraction of the image, xI , to Mote 1 for processing and processes locally the remaining part. Mote 1 starts processing its part as soon as it has received it.

Find out the value of x for which the camera node and the plain mote stop processing at the same time (initial time is the time the camera node sends out the first bit of xI to the plain mote). The capacity of the link camera-Mote 1 is $C=1$ [Mb/s] and the processing rates of the camera and Mote 1 are, respectively, $v_c = 100$ [kb/s] and $v_1 = 500$ [kb/s].

Find out the corresponding total energy consumption under the following parameters:

- Energy for transmitting/receiving: $E_{tx} = E_{rx} = 50$ [nJ/bit](including circuitry and transmission energy)
- Energy for processing $E_{proc} = 100$ [nJ/bit]

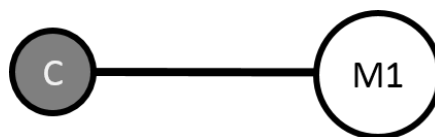

Figure 3

5. Sensor node 1 and sensor node 2 are equipped with cameras and collect images with size $I=12.8$ [kbyte]. The two sensors have to deliver the images to sensor 3 by using packets whose length is $L=128$ [byte]. Assuming that: the energy required to operate the TX/RX circuitry is $E_c = 6$ [μJ /packet], the energy required to support sufficient transmission output power $E_{tx}(d) = k * d^2$ [nJ /packet], with $k = 120$ [$\frac{nJ}{packet} / m^2$], find the total energy consumption (energy consumed by sensor 1, sensor 2 and sensor 3) to deliver one single image each in the following two cases:
- Sensor 1 and sensor 2 send directly the images to the sink.
 - Sensor 1 sends the image to sensor 2, sensor 2 sends to sensor 3 its own image and a compressed version of sensor 1's image (compression ratio 0.1, that is, the compressed image has size $0.1 * I$). In this case, the energy required by sensor 2 to compress the image is $E_p = 0.1$ [μJ] for each packet of the original uncompressed image

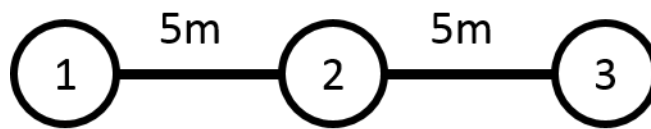

Figure 4