

# Smart Sensors for IoT

## Exercise 4 (27.10.2021)

Christian Enz

Swiss Federal Institute of Technology (EPFL), Lausanne, Switzerland

### Problem 1 Active Band-Pass Filter

Consider the Active Band-Pass Filter shown in Fig. 1, with an ideal amplifier, except that it is noisy (you can consider just an equivalent voltage noise source at the negative input neglecting the amplifier current noise sources at its input for the sake of simplicity) and noisy resistors:

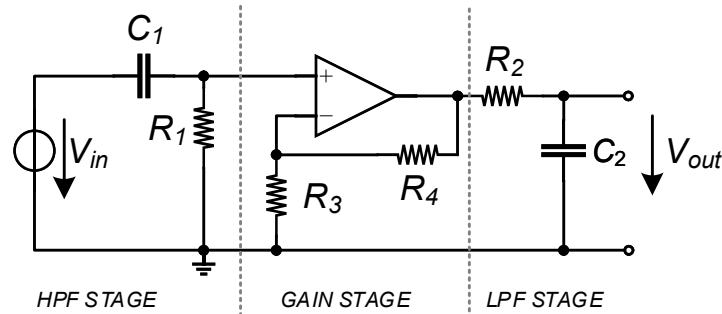

Figure 1: Active Band-Pass Filter.

Consider:  $R_2 = 4R_1$ ,  $R_3 = R_1$ ,  $R_4 = 9R_1$  and  $C_2 = 0.5C_1$  and

- derive the transfer function;
- calculate the output noise;
- calculate the input referred noise;
- calculate the output noise variance considering amplifier noise spectral density as  $S_{\Delta V_n^2}$ .

### Problem 2 Active Band-Pass Filter variant

- What happens if the HPF stage and the LPF stage in Fig. 1 are swapped? Try to repeat the previous calculation and comment.

### Problem 3 OTA-C Tow-Thomas LPF Noise Analysis

Consider the OTA-C Tow-Thomas LPF Noise Analysis shown in Fig. 2, with an ideal OTA, except that it is noisy).

Consider:  $G_{m1} = G_{m2} = G_m$ ,  $C_1 = C_2 = C$ ,  $G_{m3} = G_m/Q$ ,  $\omega_0 = G_m/C$ , and

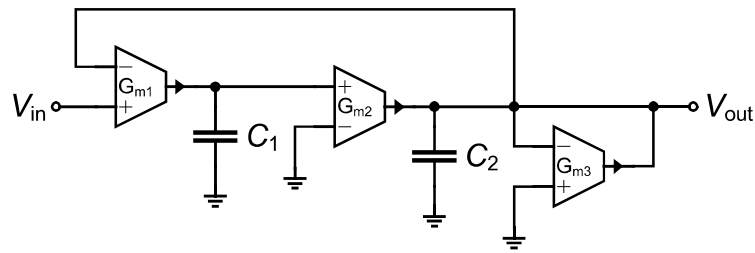

Figure 2: OTA-C Tow-Thomas LPF.

- calculate the output noise;
- calculate the input referred noise;
- calculate the output noise variance considering OTA noise spectral density as  $4kT/G_{m*}$ ;
- finally size the components in order to synthesize a 2nd order Butter worth filter (that is,  $Q = 1/\sqrt{2}$ ) with  $\omega_0 = 2\pi \cdot 100$  krad/s and output noise voltage variance at room temperature ( $T = 300$  K) less than  $15 \times 10^{-9}$  nV<sup>2</sup>/Hz.