

# Video Compression Standards II

Prof. Dr. Touradj Ebrahimi



Multimedia Signal Processing Group  
Ecole Polytechnique Fédérale de Lausanne



1

## H.264/AVC coding architecture (reminder)

2

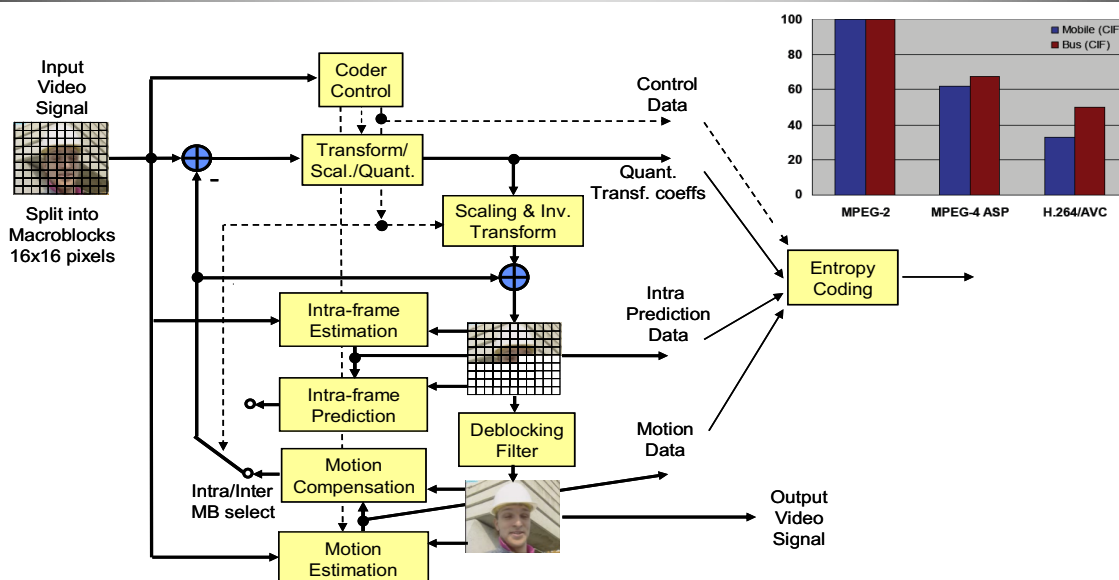

Multimedia Signal Processing Group  
Ecole Polytechnique Fédérale de Lausanne



2

## Scalable Video Coding

3

Scalability is a functionality regarding the useful decoding of parts of the encoded bitstream, ideally

1. while achieving an RD performance at any supported spatial, temporal, or SNR resolution that is comparable to single-layer coding at that particular resolution, and
2. without significantly increasing the decoding complexity.

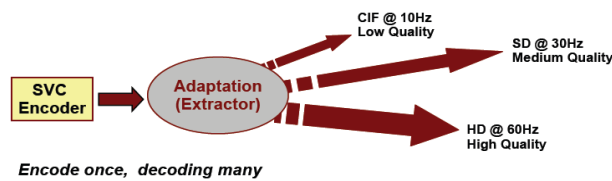

Multimedia Signal Processing Group  
Ecole Polytechnique Fédérale de Lausanne



3

## SVC Requirements

4

- Similar **coding efficiency** compared to single-layer coding for each subset of the scalable bit stream.
- Little increase in **decoding complexity** compared to single-layer decoding that scales with the decoded spatio-temporal resolution and bit rate.
- Support of **temporal, spatial, and quality scalability**.
- Support of a **backward compatible base layer** (H.264/AVC in this case).
- Support of simple **bitstream adaptations** after encoding.



Multimedia Signal Processing Group  
Ecole Polytechnique Fédérale de Lausanne



4

## SVC coding architecture

5

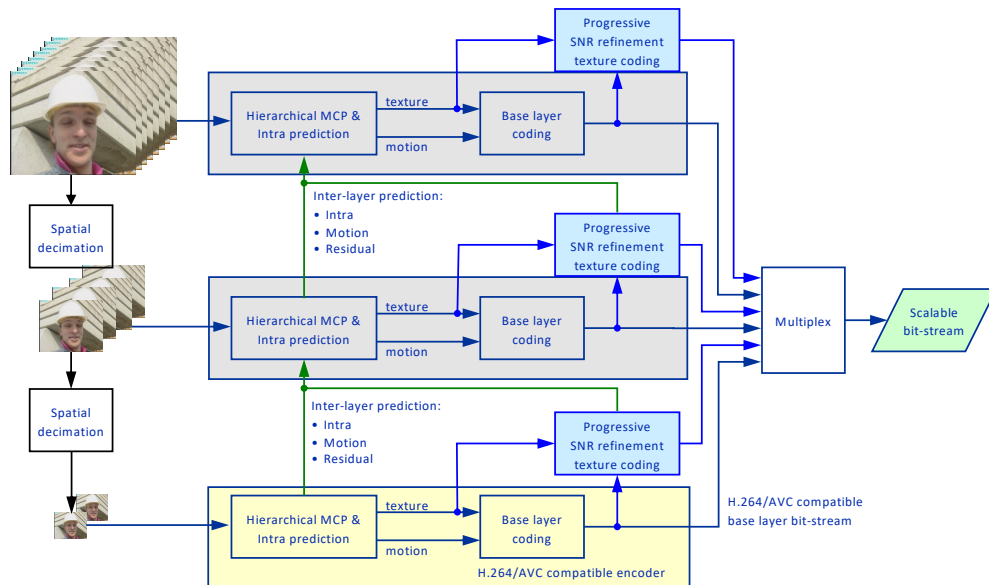

Multimedia Signal Processing Group  
Ecole Polytechnique Fédérale de Lausanne



5

## Hierarchical Prediction Structures for Temporal Scalability

6

- (a) coding with hierarchical B pictures,
- (b) non-dyadic hierarchical prediction structure,
- (c) hierarchical prediction structure with a structural encoder/decoder delay.

The numbers below the pictures specify the coding order, and the symbols  $T_k$  specify the temporal layers with  $k$  representing the corresponding temporal layer identifier.

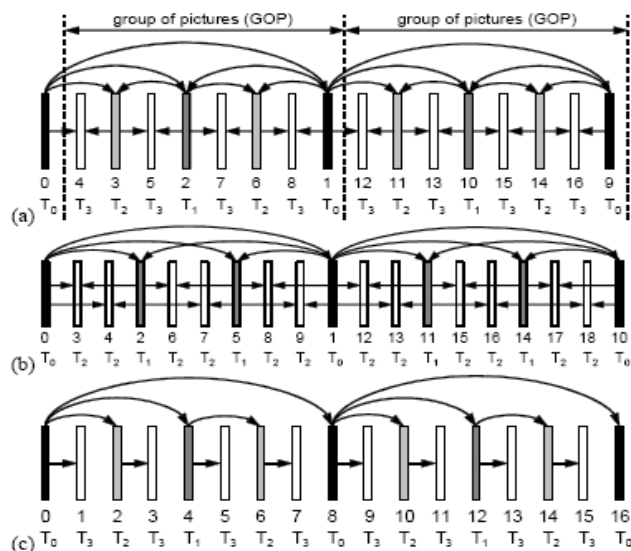

Multimedia Signal Processing Group  
Ecole Polytechnique Fédérale de Lausanne



6

## Network Abstraction Layer (NAL)

7

- NAL is designed to provide "network friendliness"
- One NAL unit can contain control data or encoded slices of video
  - NAL Unit (NALU) is the smallest entity that can be handled by the decoder individually
  - One slice may contain (theoretically) just one macroblock, whole frame or (usually) something between
  - It is usually most appropriate to allocate one NALU in one transport packet

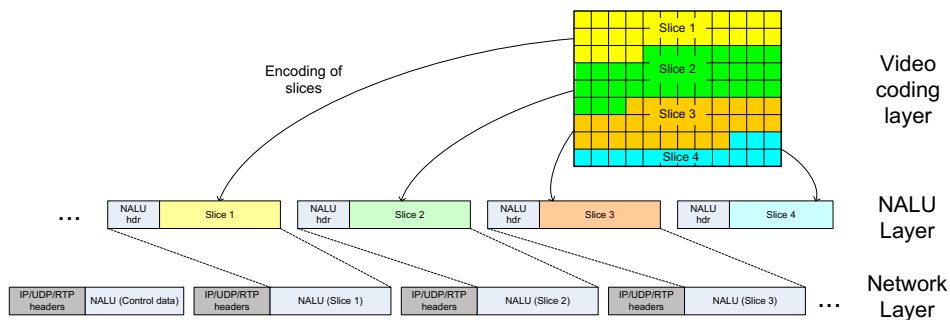

Multimedia Signal Processing Group  
Ecole Polytechnique Fédérale de Lausanne



7

## Moore's law of compression

8

- ... between different paradigms ...

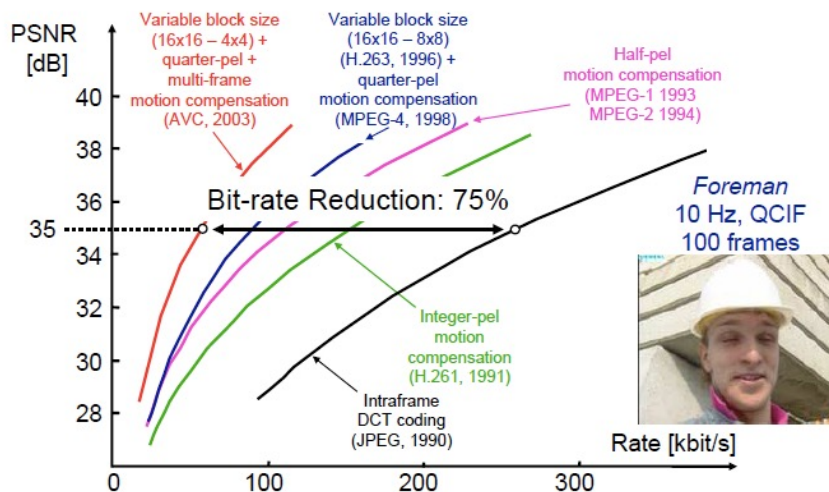

Multimedia Signal Processing Group  
Ecole Polytechnique Fédérale de Lausanne



8

# HEVC video coding standard

9

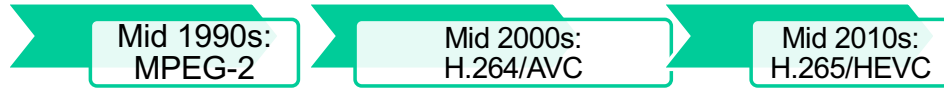

- HEVC version 1 was completed in January 2013
  - Standardized by ISO/IEC as **ISO/IEC 23008-2** (MPEG-H Part 2)
  - Standardized by ITU-T as **H.265**
  - Several profiles: Main, 10 bit, still picture (HEIF), ...

9

# HEVC coding architecture

10

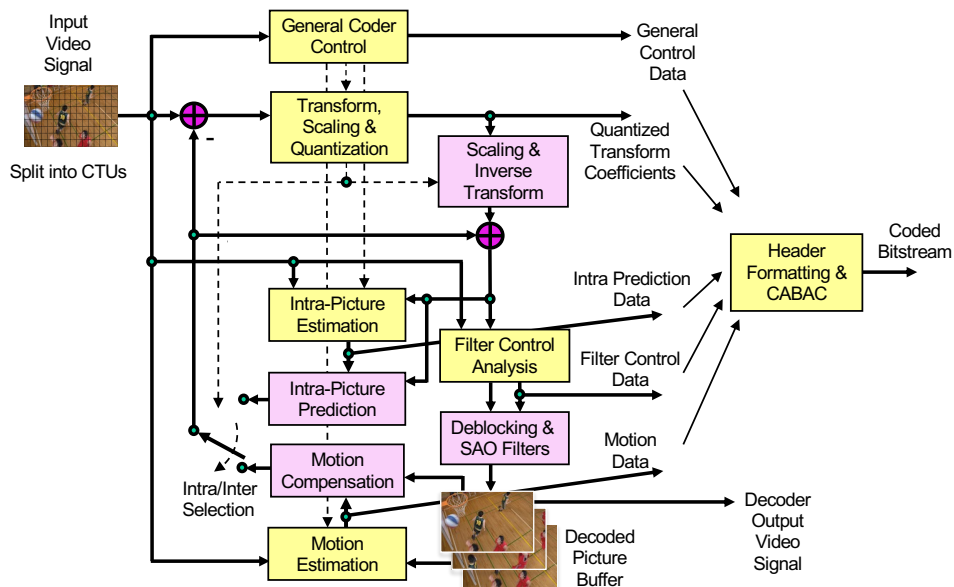

10

## Largest Coding Unit (LCU)

11

- Consists of an  $N \times N$  block of luma samples together with two corresponding blocks of chroma samples for a picture
- Broadly analogous to that of the macroblock in previous standards such as H.264/AVC
- In H.264/HEVC the maximum allowed size of the luma block in a LCU is  $64 \times 64$
- Smallest Coding Unit (SCU)

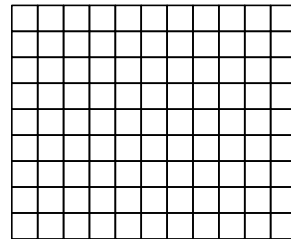

Multimedia Signal Processing Group  
Ecole Polytechnique Fédérale de Lausanne

EPFL

11

## Coding Tree Unit (CTU)

12

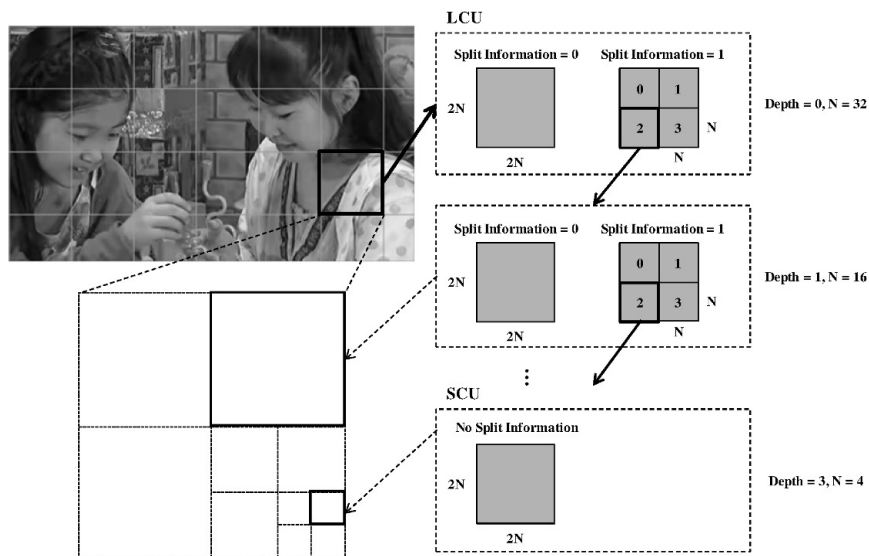

Multimedia Signal Processing Group  
Ecole Polytechnique Fédérale de Lausanne

EPFL

12

## Prediction Unit (PU)

13

- Basic unit for information on prediction processes
- Not restricted to square
- Each CTU contains one or more PUs

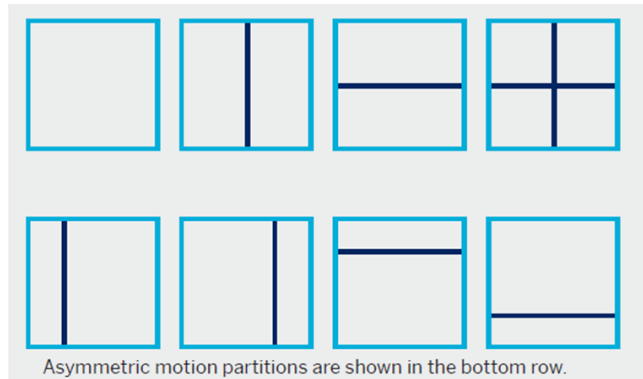

Multimedia Signal Processing Group  
Ecole Polytechnique Fédérale de Lausanne

EPFL

13

## Transform Unit (TU)

14

- Basic unit for transform and quantization processes
- Its shape depends on PU partitioning mode
- Maximum 3 levels

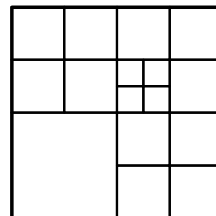

Multimedia Signal Processing Group  
Ecole Polytechnique Fédérale de Lausanne

EPFL

14

```

nS = 4
{64, 64, 64, 64}
{83, 36, -36, -83}
{64, -64, -64, 64}
{36, -83, 83, -36}

nS = 8
{64, 64, 64, 64, 64, 64, 64, 64}
{89, 75, 50, 18, -18, -50, -75, -89}
{83, 36, -36, -83, -36, 36, 83}
{75, -18, -89, -50, 50, 89, 18, -75}
{64, -64, -64, 64, 64, -64, -64, 64}
{50, -89, 18, 75, -75, -18, 89, -50}
{36, -83, 83, -36, 36, 83, -36}
{18, -50, 75, -89, 89, -75, 50, -18}

nS = 16
{64 64 64 64 64 64 64 64 64 64 64 64 64 64 64 64}
{90 87 80 70 57 43 25 9 -9-25-43-57-70-80-87-90}
{89 75 50 18-18-50-75-89-89-75-50-18 18 50 75 89}
{87 57 9-43-80-90-70-25 25 70 90 80 43 -9-57-87}
{83 36-36-83-83-36 36 83 36-36-83-83-36 36 83}
{80 9-70-87-25 57 90 43-43-90-57 25 87 70 -9-80}
{75-18-89-50 50 89 18-75-75 18 89 50-50-89-18 75}
{70-43-87 9 90 25-80-57 57 80-25-90 -9 87 43-70}
{64-64-64 64 64-64-64 64 64-64-64 64 64-64-64 64}
{57-80-25 90 -9-87 43 70-70-43 87 9-90 25 80-57}
{50-89 18 75-75-18 89-50-50 89-18-75 75 18-89 50}
{43-90 57 25-87 70 9-80 80 -9-70 87-25-57 90-43}
{36-83 83-36-36 83-83 36 36-83 83-36-36 83-83 36}
{25-70 90-80 43 9-57 87-87 57 -9-43 80-90 70-25}
{18-50 75-89 89-75 50-18-18 50-75 89-89 75-50 18}
{9-25 43-57 70-80 87-90 90-87 80-70 57-43 25 -9}

nS = 32
{64 64 64 64 64 64 64 64 64 64 64 64 64 64 64 64 64 64 64 64 64 64 64 64 64 64 64 64 64 64}
{90 90 88 85 82 78 73 67 61 54 46 38 31 22 13 4 -4-13-22-31-38-46-54-61-67-73-78-82-85-88-90-90}
{90 87 80 70 57 43 25 9 -9-25-43-57-70-80-87-90-90-87-80-70-57-43-25 -9 9 25 43 57 70 80 87 90}
{90 82 67 46 22 -4-31-54-73-85-90-88-78-61-38-13 13 38 61 78 88 90 85 73 54 31 4-22-46-67-82-90}
{89 75 50 18-18-50-75-89-89-75-50-18 18 50 75 89 89 75 50 18-18-50-75-89-89-75-50-18 18 50 75 89}
{88 67 31-13-54-82-90-78-46 -4 38 73 90 85 61 22-22-61-85-90-73-38 4 46 78 90 82 54 13-31-67-88}
{87 57 9-43-80-90-70-25 25 70 90 80 43 -9-57-87-87-57 -9 43 80 90 70 25-25-70-90-80-43 9 57 87}
{85 46-13-67-90-73-22 38 82 88 54 -4-61-90-78-31 31 78 90 61 4-54-88-82-38 22 73 90 67 13-46-85}
{83 36-36-83-83-36 36 83 36-36-83-83-36 36 83 83 36-36-83-83-36 36 83 83 36-36-83-83-36 36 83 36-36-83-83-36 36 83}
{82 22-54-90-61 13 78 85 31-46-90-67 4 73 88 38-38-88-73 -4 67 90 46-31-85-78-13 61 90 54-22-82}
{80 9-70-87-25 57 90 43-43-90-57 25 87 70 -9-80-80 -9 70 87 25-57-90-43 43 90 57-25-87-70 9 80}
{78 -4-82-73 13 85 67-22-88-61 31 90 54-38-90-46 46 90 38-54-90-31 61 88 22-67-85-13 73 82 4-78}
{75-18-89-50 50 89 18-75-75 18 89 50-50-89-18 75 75-18-89-50 50 89 18-75-75 18 89 50-50-89-18 75}
{73-31-90-22 78 67-38-90-13 82 61-46-88 -4 85 54-54-85 4 88 46-61-82 13 90 38-67-78 22 90 31-73}
{70-43-87 9 90 25-80-57 57 80-25-90 -9 87 43-70-70 43 87 -9-90-25 80 57-57-80 25 90 9-87-43 70}
{67-54-78 38 85-22-90 4 90 13-88-31 82 46-73-61 61 73-46-82 31 88-13-90 -4 90 22-85-38 78 54-67}
{64-64-64 64 64-64-64 64 64-64-64 64 64-64-64 64 64-64-64 64 64-64-64 64 64-64-64 64 64-64-64 64}
{61-73-46 82 31-88-13 90 -4-90 22 85-38-78 54 67-67-54 78 38-85-22 90 4-90 13 88-31-82 46 73-61}
{57-80-25 90 -9-87 43 70-70-43 87 9-90 25 80-57-57 80 25-90 9 87-43-70 70 43-87 -9 90-25-80 57}
{54-85 -4 88-46-61 82 13-90 38 67-78-22 90-31-73 73 31-90 22 78-67-38 90-13-82 61 46-88 4 85-54}
{50-89 18 75-75-18 89-50-50 89-18-75 75 18-89 50 50-89 18 75-75-18 89-50-50 89-18-75 75 18-89 50}
{46-90 38 54-90 31 61-88 22 67-85 13 73-82 4 78-78 -4 82-73-13 85-67-22 88-61-31 90-54-38 90-46}
{43-90 57 25-87 70 9-80 80 -9-70 87-25-57 90-43-43 90-57-25 87-70 -9 80-80 9 70-87 25 57-90 43}
{38-88 73 -4-67 90-46-31 85-78 13 61-90 54 22-82 82-22-54 90-61-13 78-85 31 46-90 67 4-73 88-38}
{36-83 83-36-36 83-83 36 36-83 83-36-36 83-83 36 36-83 83-36-36 83-83 36 36-83 83-36-36 83-83 36}
{31-78 90-61 4 54-88 82-38-22 73-90 67-13-46 85-85 46 13-67 90-73 22 38-82 88-54 -4 61-90 78-31}
{25-70 90-80 43 9-57 87-87 57 -9-43 80-90 70-25-25 70-90 80-43 -9 57-87 87-57 9 43-80 90-70 25}
{22-61 85-90 73-38 -4 46-78 90-82 54 13-31 67-88 88-67 31 13-54 82-90 78-46 4 38-73 90-85 61-22}
{18-50 75-89 89-75 50-18-18 50-75 89-89 75-50 18 18-50 75-89 89-75 50-18 18-50-75 89-89 75-50 18}
{13-38 61-78 88-90 85-73 54-31 4 22-46 67-82 90-90 82-67 46-22 -4 31-54 73-85 90-88 78-61-38-13}
{9-25 43-57 70-80 87-90 90-87 80-70 57-43 25 -9 -9 25-43 57-70 80-87 90-90 87-80 70-57-43 25 9}
{4-13 22-31 38-46 54-61 67-73 78-82 85-88 90-90 90-90 88-85 82-78 73-67 61-54 46-38 31-22 13 -4}
    
```

- HEVC supports :
  - 33 directional modes
  - planar (surface fitting)
  - DC prediction (flat)

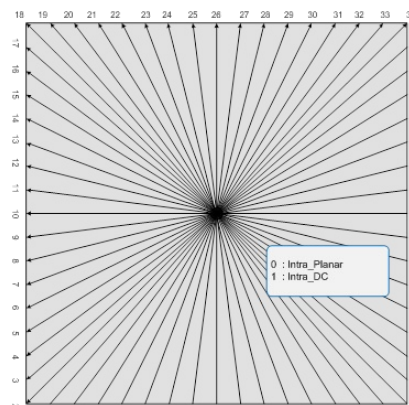

# Partition structure comparison

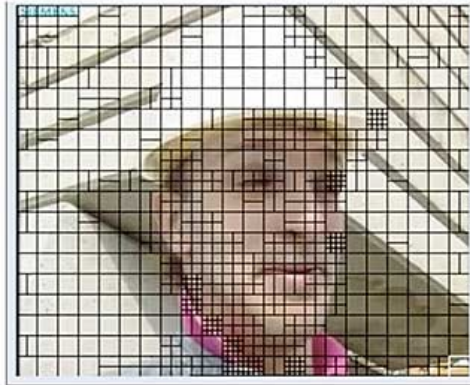

H.264

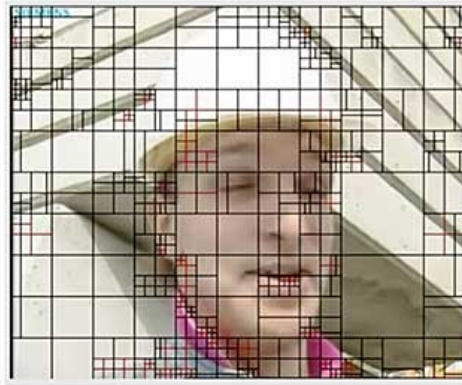

H.265

# Coding Tree Unit (CTU) examples

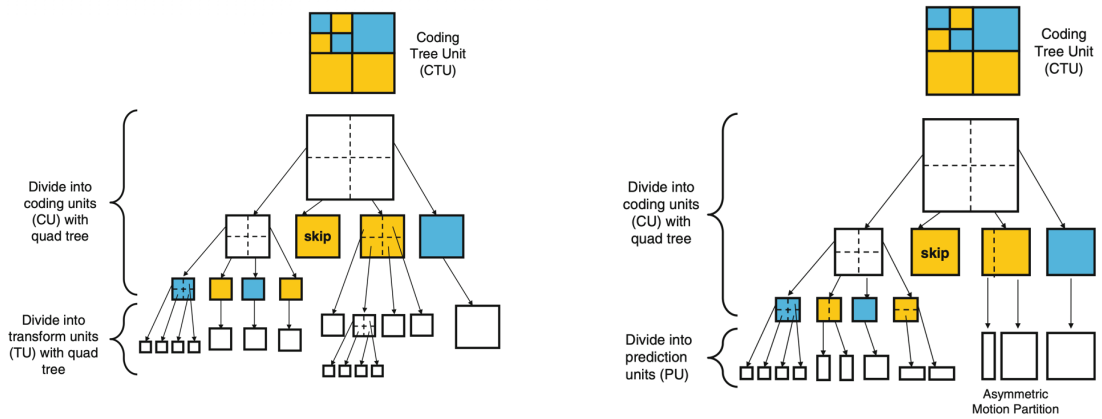

## Intra-only coding configuration

19

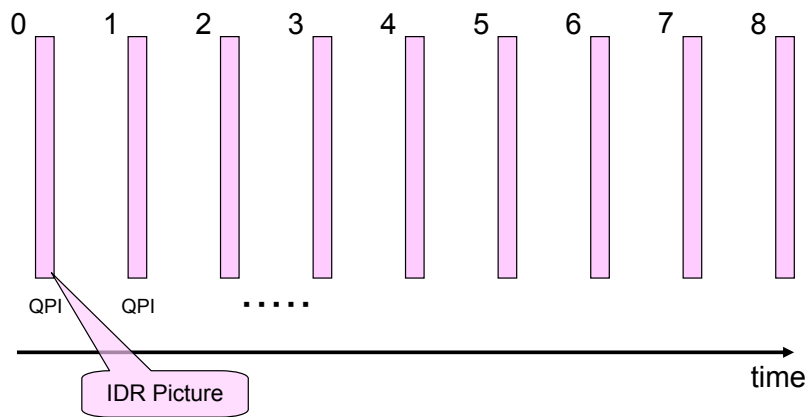

**IDR: Instantaneous Decoder Refresh**



Multimedia Signal Processing Group  
Ecole Polytechnique Fédérale de Lausanne



19

## Low-delay configuration

20

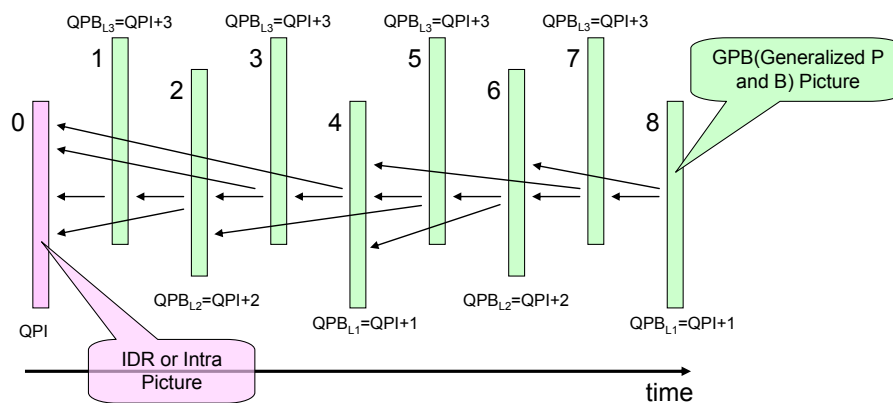

Multimedia Signal Processing Group  
Ecole Polytechnique Fédérale de Lausanne



20

## Random-access configuration

21

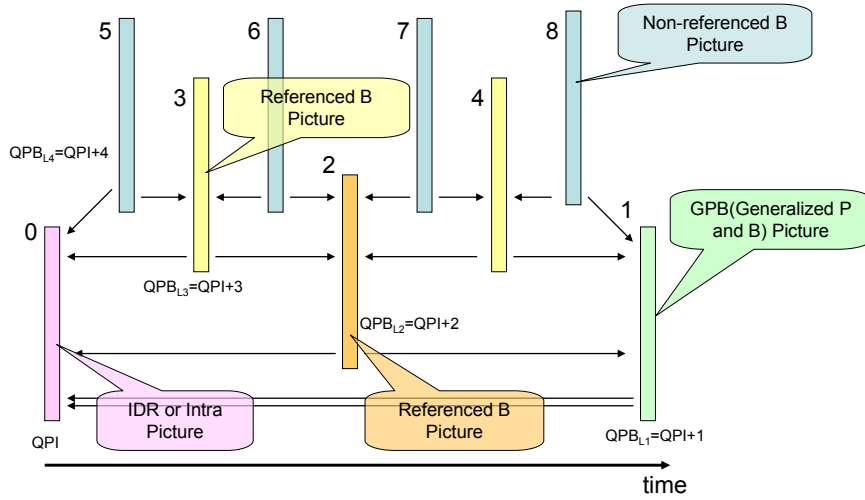

Multimedia Signal Processing Group  
Ecole Polytechnique Fédérale de Lausanne



21

## Hierarchical B frames configuration

22

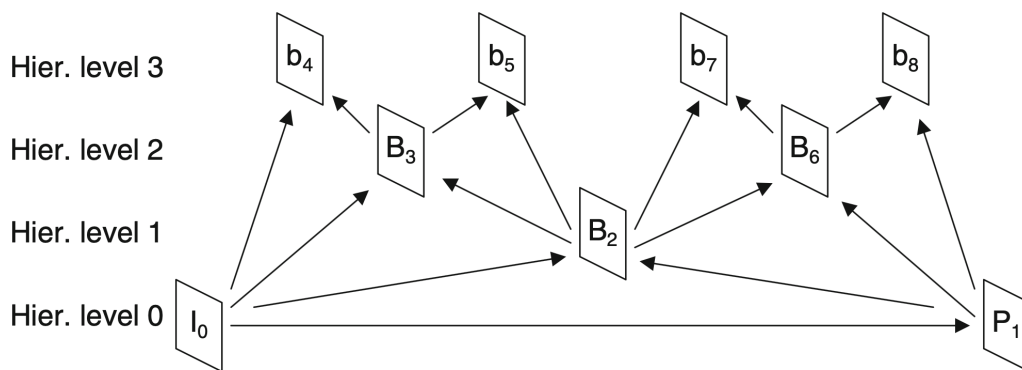

Multimedia Signal Processing Group  
Ecole Polytechnique Fédérale de Lausanne



22

- Deblocking filter same as H.264/AVC
- 4x4 block boundaries not deblocked to reduce the complexity
- Sample Adaptive Offset (SAO)
- Adaptive Loop Filter (ALF)



Feature	MPEG-2	AVC	HEVC
Macroblock size	16X16	16X16	CTU, NXN (N=16, 32, 64)
Block size	8X8	16X16, 16X8, 8X16, 8X8, 4X8, 8X4, 4X4	Tree structure from 64X64 to 4X4
Intra prediction	No	Spatial domain, 8 modes	33 directional modes Planar (surface fitting) DC prediction (flat)
Transform	8X8 DCT	8X8, 4X4 integer DCT 4X4, 2X2 Hadamard	32X32 to 4X4 integer DCT Tree structured
Entropy coding	VLC	CAVLC, CABAC	CABAC
Pel accuracy	1/2	1/4	1/4
Reference picture	1	Multiple	Multiple
Wighted prediction	No	Yes	Yes
Picture types	I,P, B	I, P, B, SI, SP	IDR, GPB, Referenced B



# HEVC Screen Content Coding (SCC)

25

- For video containing a significant portion of rendered (moving or static) graphics, text, or animation
- Use for wireless displays, remote computer desktop access, real-time screen sharing for videoconferencing, news with scrolling graphics, etc.

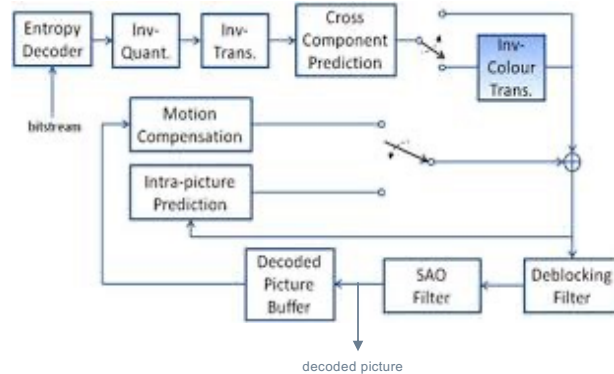

Multimedia Signal Processing Group  
Ecole Polytechnique Fédérale de Lausanne



25

# SCC specific coding tools

26

- **Palette mode**
  - Directly code values of samples (no transform) to create palette
  - Palette prediction from region to region
  - Scan to copy from above, left, palette index or escape
- **Current-picture referencing (a.k.a. Intra block copy)**
  - Like motion compensation, but within the current picture
  - Displacement vectors are integer-valued
  - Essentially otherwise identical to inter-picture referencing
- **Adaptive MV resolution**
  - Displacement vectors for inter-picture prediction of sequence or slice can be restricted to integer values
- **Adaptive color transform (based on YCoCg)**
  - Cross-component colour-transform within the decoding process
  - Especially helpful for coding RGB-format video
  - Based on YCoCg-R (a lifting-based reversible colour transform)
- **Intra boundary filtering disabling**
  - Very small modification to prevent blurring of predictors



Multimedia Signal Processing Group  
Ecole Polytechnique Fédérale de Lausanne



26

# Compression efficiency comparison

