

# Quantum Cellular Automata (QCA) and Wireless Logic

## Lecture #9 - Nanoelectronics

Adrian M. Ionescu

2019

# Summary

- **Quantum Cellular Automata (QCA):** history and basics
- Role of the **clock in QCA**
- **Technological implementations:**
  - metal-dot QCA
  - molecular QCA
  - magnetic QCA
- **Opportunities and challenges**

# New paradigm: Quantum-dot Cellular Automata (QCA)

**Represent information with a switchable molecular charge configuration instead of a current switch.**

- Revolutionary, not incremental, approach.
- Beyond transistors – requires rethinking circuits and architectures with devices that are not working as transistors.
- Use quantum dots and molecules, not as current switches, but as **structured charge containers**.
- The resulting logic structures are ‘wireless’: do not need dedicated metal interconnects for transferring the information from the processing logic cells.

# Short history

- Proposed in **1993 by Lent et al.** (Lent, Tougaw, Porod, Bernstein, Quantum cellular automata, Nanotechnology 4 (1), 49, 1993).
- Based on **ground state computation**: system moves to lowest electro-static energy state.
- State of lowest energy uniquely defined. Key issue is energy level between states and  $kT$ .
- 1997 first physical implementation of QCA produced tunnel junctions and Al islands with experiment at 10mK.
- Molecular and magnetic QCA implementation reported later.

# Quantum Cellular Automata (QCA)

## A Quantum-Dot Cell

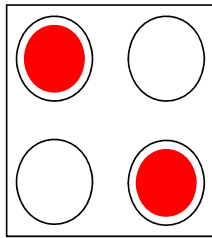

A cell with **4 dots**  
**2 extra electrons**

Representation of binary information by charge configuration

## An Array of Cells

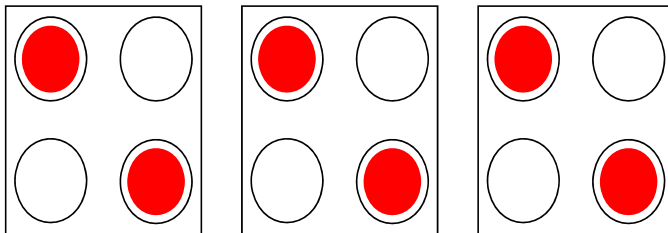

Neighboring cells tend to align due to direct Coulombic coupling

# Quantum-dot Cellular Automata (QCA)

Theory

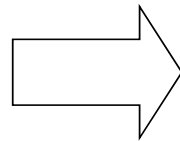
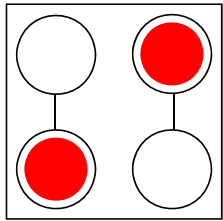

Physical implementation

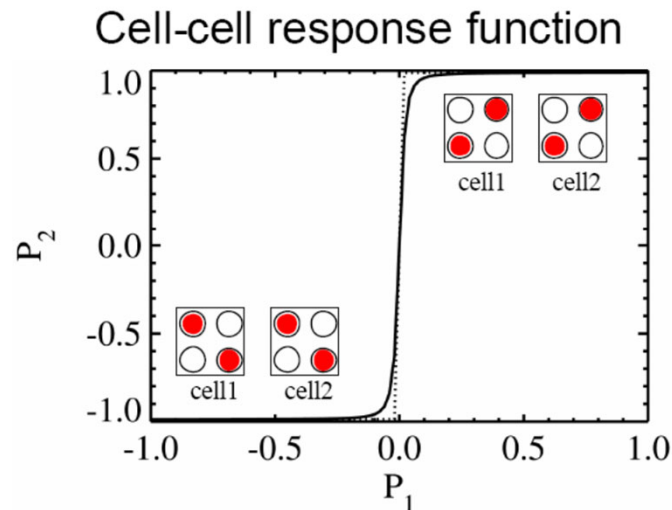
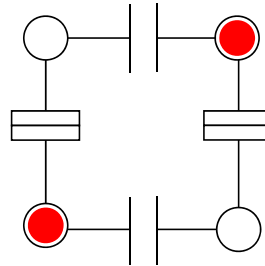

**QCA implementation:**

- 4 quantum dots coupled by tunnel junctions
- electrons can only move (tunnel) between two adjacent dots
- only two stable states possible per cell:

**'0' and '1'**

# How does it work?

- If two QCA cells are placed next to each other, it is possible to exchange their states.
- The QCA cell that should transfer (cell 1 below) its state to a neighboring cell (cell 2 below) **must have its tunnel junctions closed, the tunnel junctions in the neighboring cell have to be open**, to allow the electrons to travel through the tunnel junctions between the potential wells.
- As soon as they open, the electrons in the neighboring cell are pushed by the Coulomb force of the original cell as far away as possible and they will travel into the same potential wells as in the original cell.
- As soon as **the tunnel junctions are closed again, the transfer of the state is completed.**

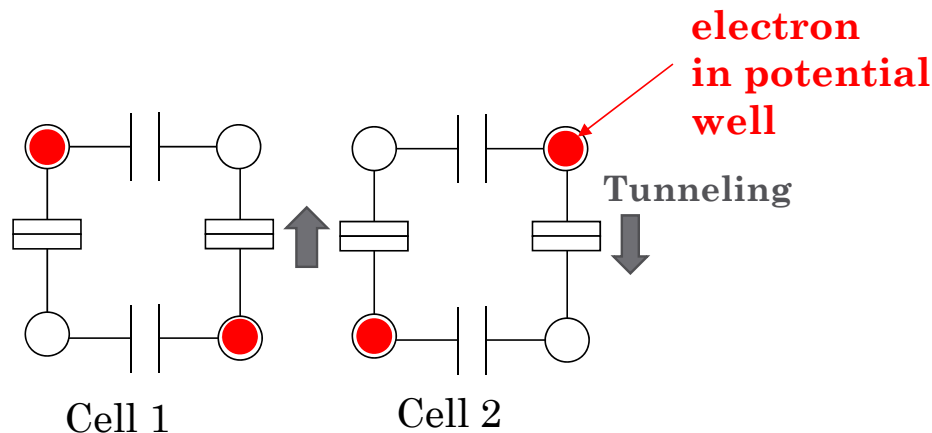

# Computing With Cells

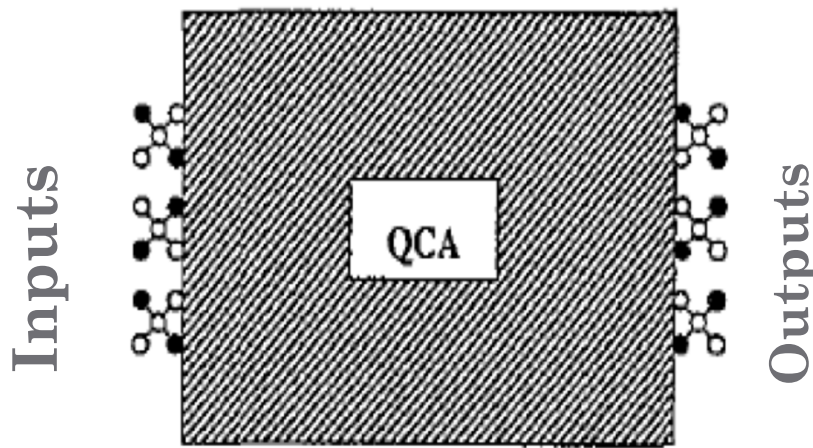

- **Edge-driven computation** – no outside interaction with internal cells.
- **Ground state** – transient states unimportant, only concerned with final, stable outputs.

## Rules:

- State of each quantum cell **dependent on its neighbors**, immediate and more distant.
- Sum-up electron interactions around a cell to determine the most energetically favorable state (“voting”).
- If interactions all cancel out (a “tie”), **most recent switching activity has more weight**.

Operation: set inputs, and follow these rules all the way to the outputs, then read outputs.

# Examples: QCA devices (1)

Propagation line or binary wire:

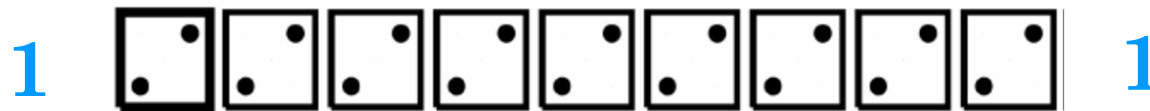

Inverter:

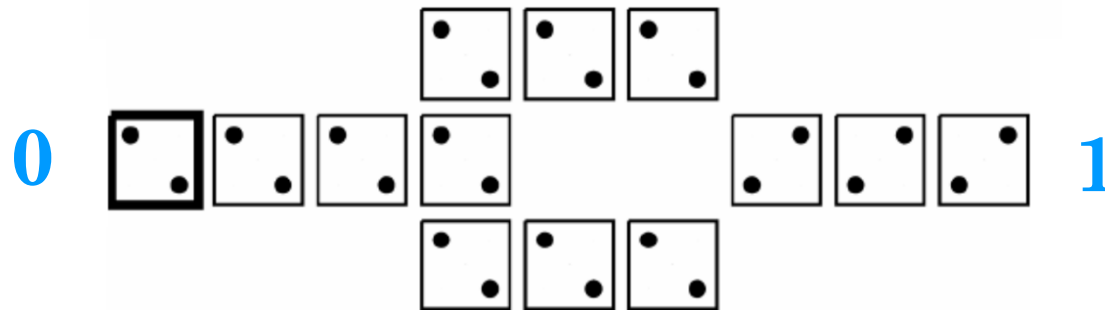

Principle: Neighboring cells tend to align due to Coulombic coupling.

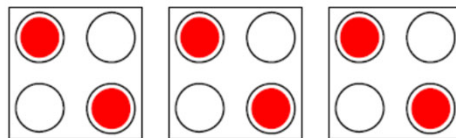

# In-plane signal propagation

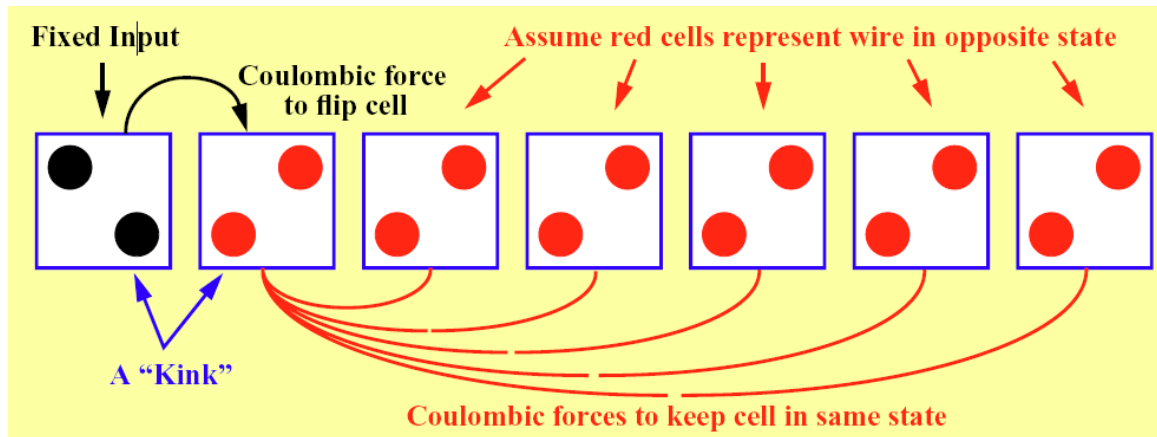

## Wire Cross in the Plane

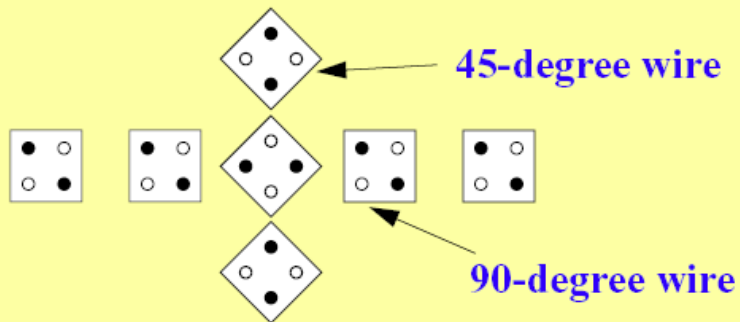

## A 45-degree Wire

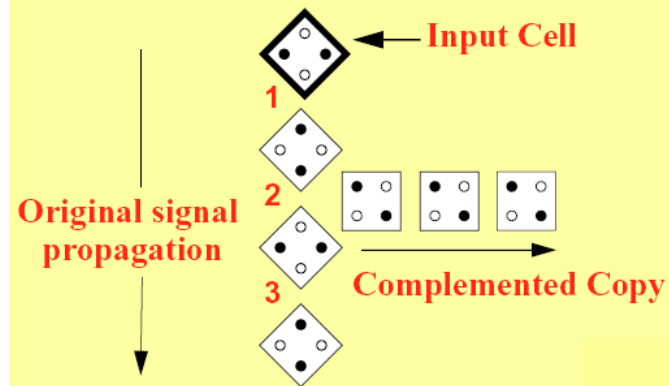

After M. T. Niemier, University of Notre Dame.

# QCA logic circuits: majority gate

QCA majority gate

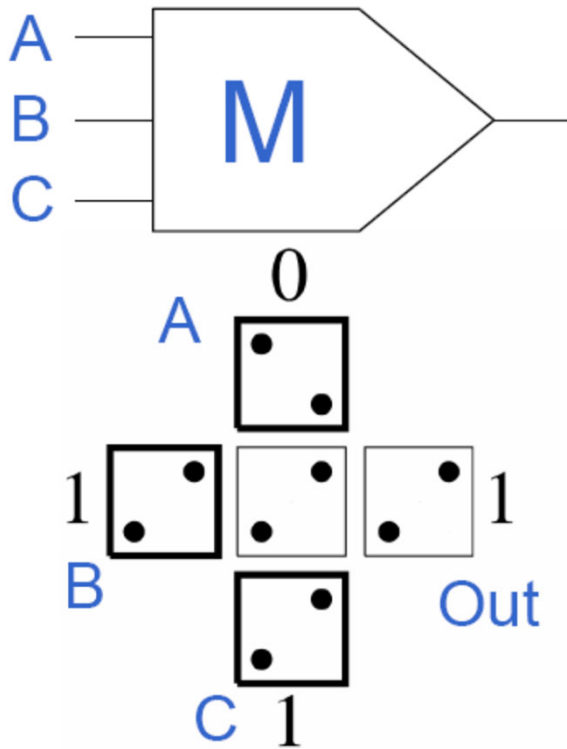

A	B	C	Output
0	0	0	0
0	0	1	0
0	1	1	1
0	1	0	0
1	1	0	1
1	1	1	1
1	0	1	1
1	0	0	0

AND gate

OR gate

2-input AND

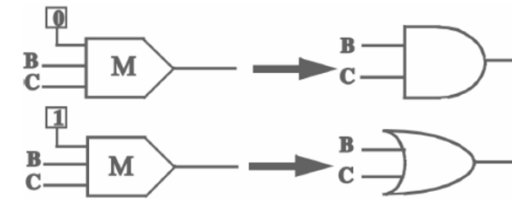

2-input OR

# QCA single-bit full adder

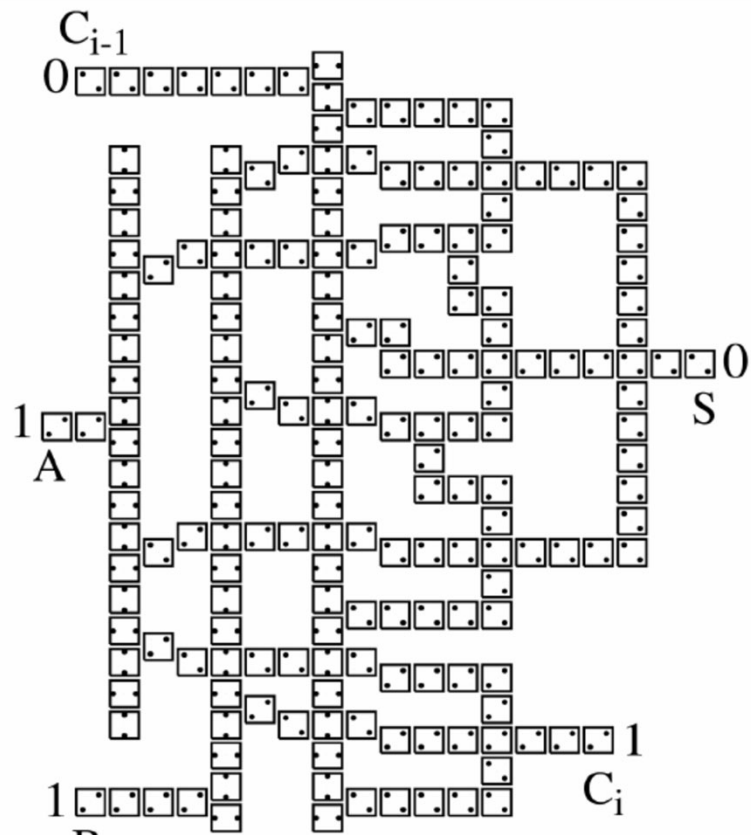
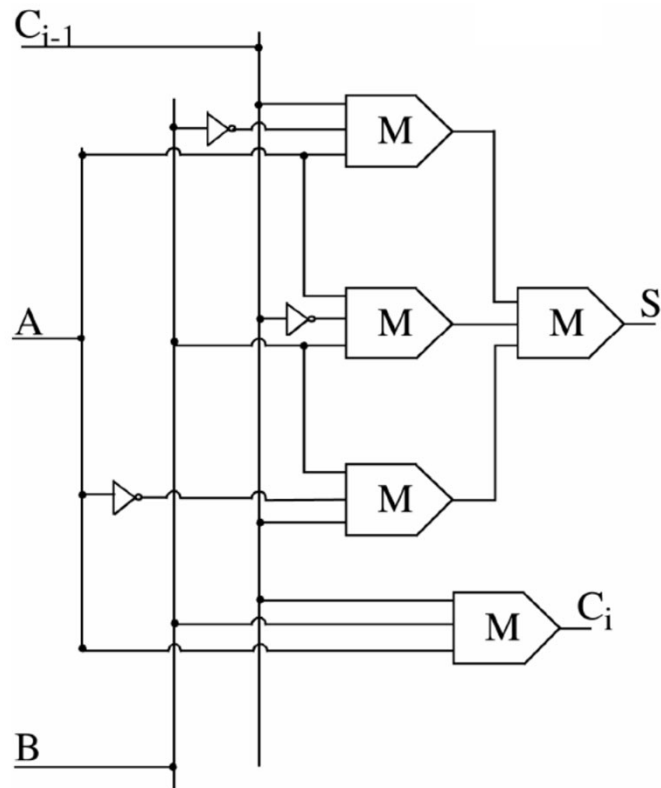

result of SC-HF calculation  
with site model

# Characteristic (kink) energy

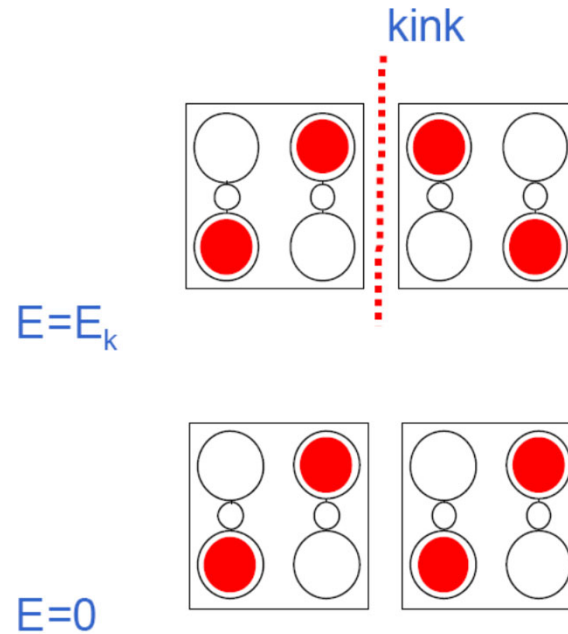

$$\text{Kink energy} = E_k > k_B T$$

Therefore operation temperature should fulfill this condition; cryogenic temperature may be required.

# Technological implementation: QCA by quantum dots

- **Regions of low potential surrounded by ring of high potential**
  - Particles (such as electrons) tend to stay within the dot because they can't cross the potential barrier.
  - Can create “tunnel junctions” that allow electrons to pass between dots.
- **Ways to implement**
  - **Metal dot & tunneling junctions** (insulator)
    - “islands” of Aluminum used as the dots
    - Al/AlO<sub>x</sub>/Al structures used as tunnel junctions
  - **Molecular junctions**
  - **Coupled magnets**

# 4-dot cell Al/AlO<sub>x</sub> on SiO<sub>2</sub>

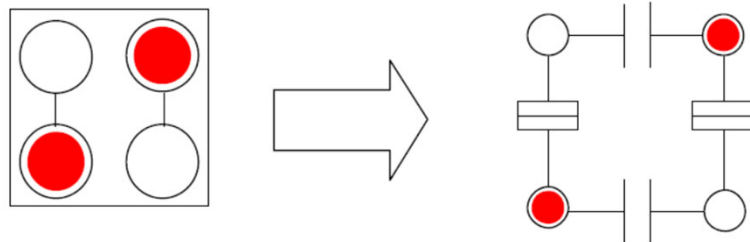

dot = metal nano-island

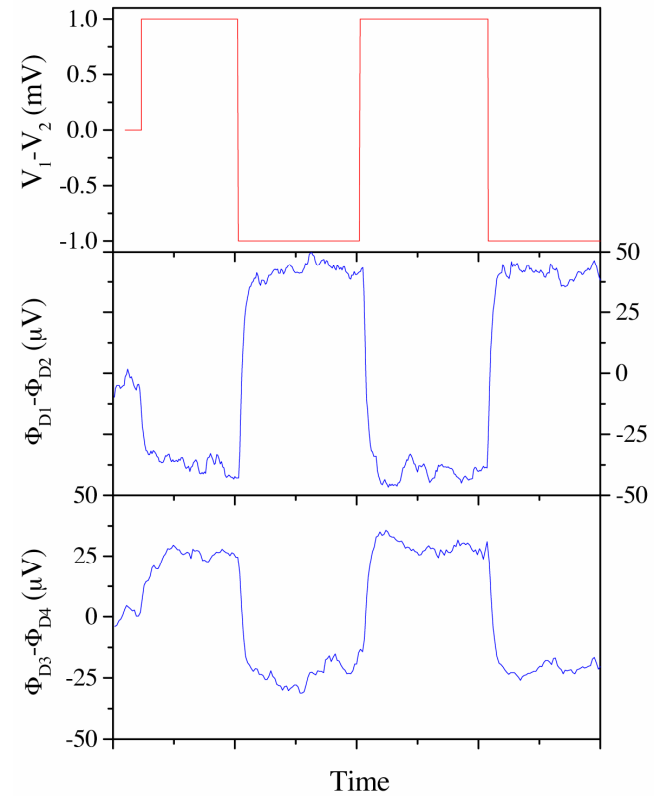
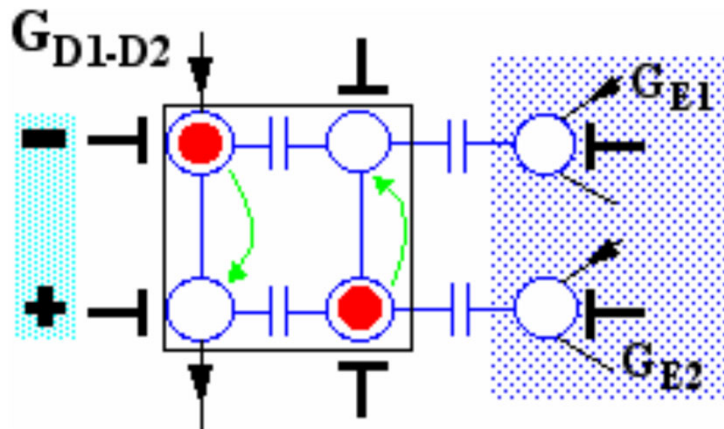

A.O. Orlov, I. Amlani, G.H. Bernstein, C.S. Lent, and G.L. Snider, *Science*, **277**, pp. 928-930, (1997).

# Majority gate QCA

Experiment (G. Snider et al, University of Notre Dame)

→ quantum dots → **Al island connected by Al/AlO<sub>x</sub>/Al tunnel junctions and lithographically defined capacitors (e-beam).**

→ Working principle @ 70mK (thermal fluctuations are cancelled out)

Inputs: A, B, C

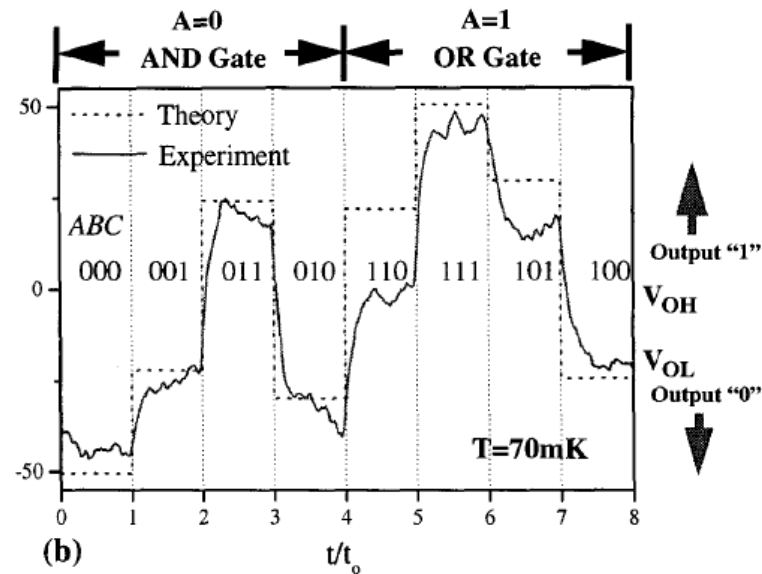
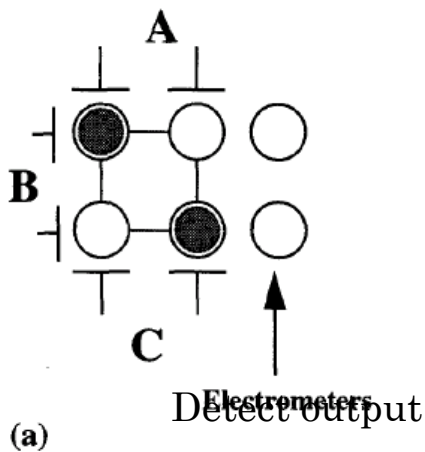

Figure 3. (a) Schematic diagram of QCA majority gate. (b) Measured output demonstrating AND/OR operation.

# Quantum Cellular Automata processor

## Clocked QCA: nanowire microprocessor architecture

- **Clock:** mandatory for real applications  
→ enables (dictates) switching between successive states
- **Quasi-adiabatic switching:** between system states the 'ground state' (equilibrium is maintained) → control of tunneling (barrier) by a gate

CLK →

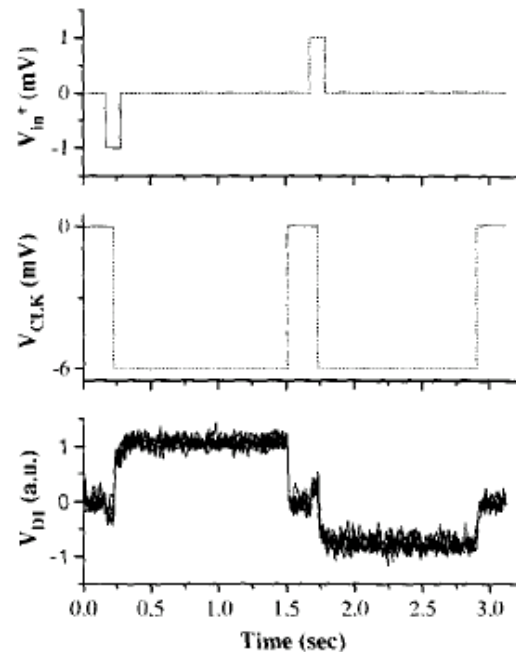

# Quantum Cellular Automata: clocking

## Four-phase system clock:

- **Switch phase** (evaluate output based on input)
  - ❑ Cells begin unpolarized
  - ❑ Tunneling barriers low
- **Hold phase** (output stable)
  - ❑ Tunneling barriers high
  - ❑ Outputs of subarrays used as inputs next stage
- **Release phase** (return system to unpolarized state)
  - ❑ Tunneling barriers low
  - ❑ Cells relaxed to unpolarized
- **Relax phase** (cell stays in unpolarized state)
  - ❑ Tunneling barriers low, cells in unpolarized state

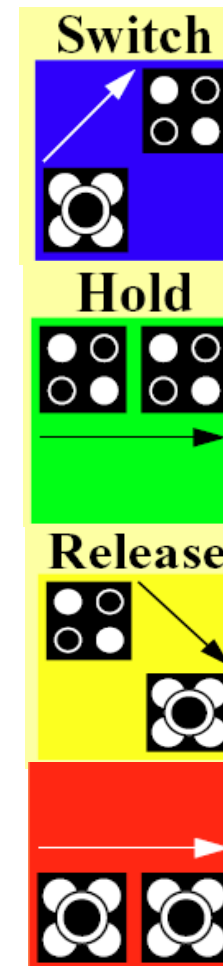
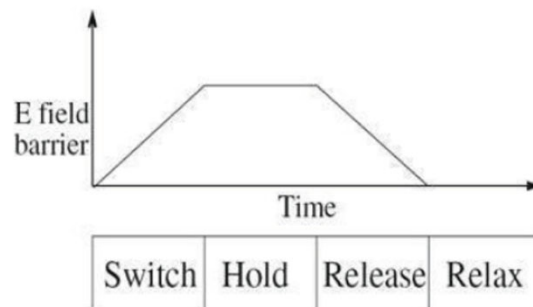

# Power gain and clock in QCA

Power gain is crucial for practical devices because some energy is always lost between stages.

- Lost energy must be replaced.
- Conventional devices – current from power supply
- QCA devices take energy from the clock
- Unity power gain means replacing exactly as much energy as is lost to environment.

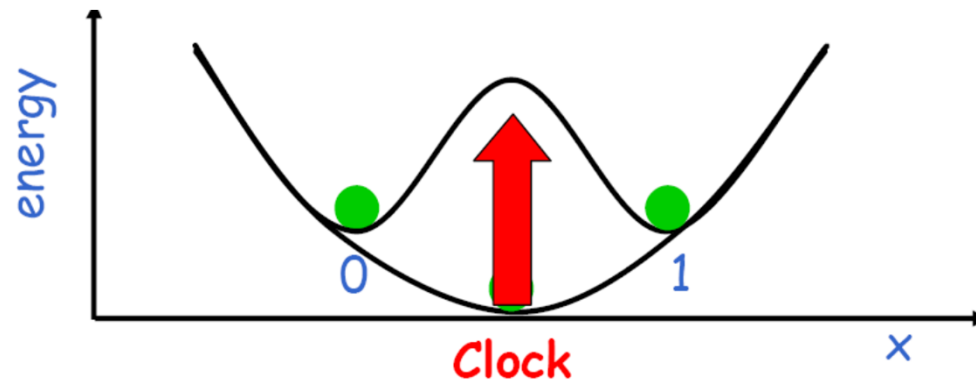

# Observation of Magnetic Field Coupling

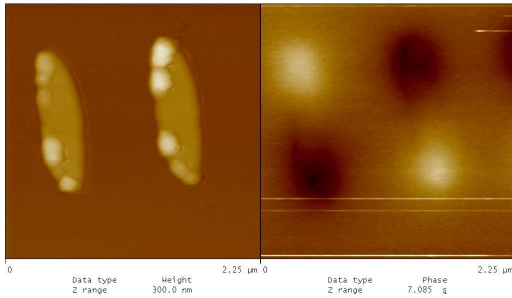

**Atomic-Force and Magnetic-Force Microscopy (AFM and MFM)**

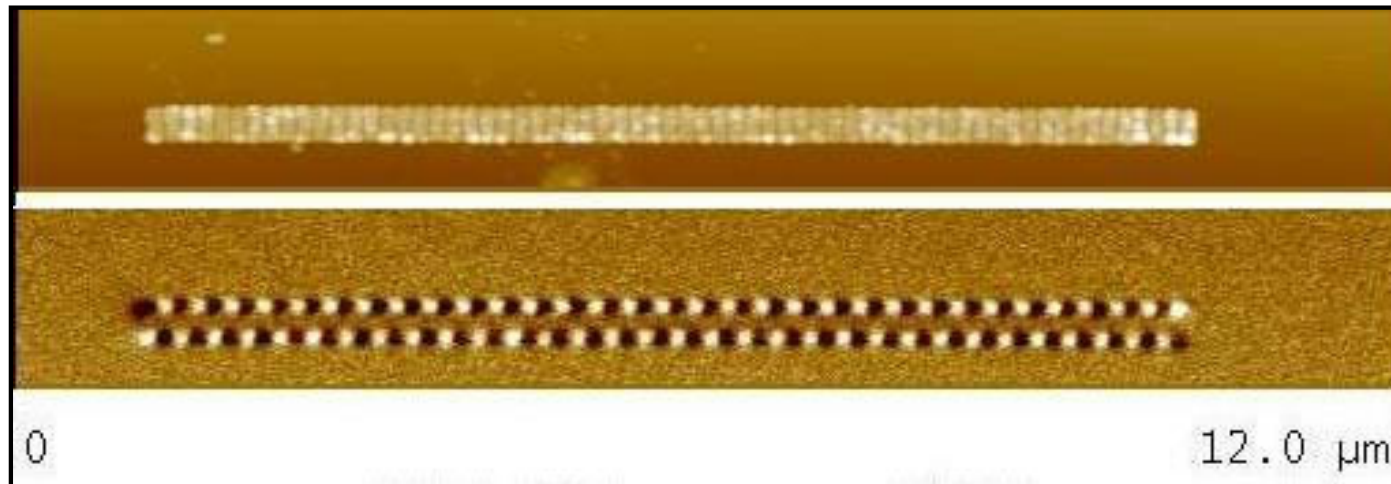

# Majority gate geometry with nanomagnets

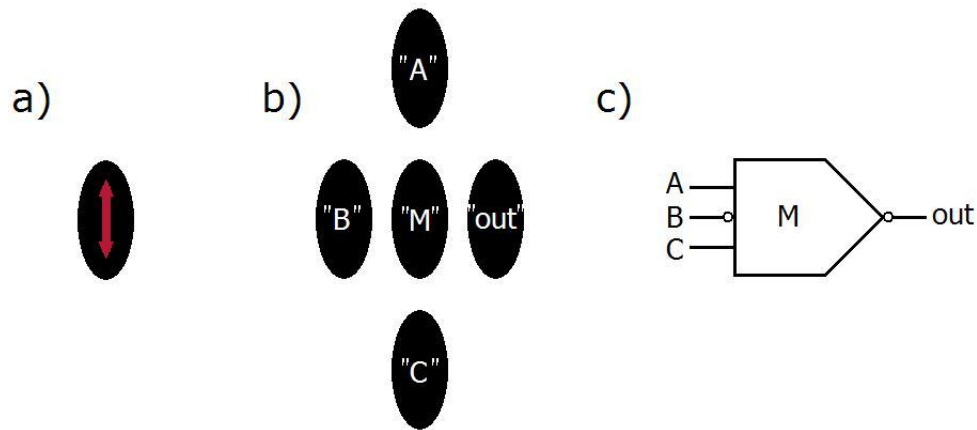

A	B	C	$\bar{A}\bar{B}C$	M	out
0	0	0	0 1 0	0	1
0	0	1	0 1 1	1	0
1	0	0	1 1 0	1	0
1	0	1	1 1 1	1	0
0	1	0	0 0 0	0	1
0	1	1	0 0 1	0	1
1	1	0	1 0 0	0	1
1	1	1	1 0 1	1	0

if B=0 then  
out=NOR(A,C)

if B=1 then  
out=NAND(A,C)

# Demonstration of majority gate operation

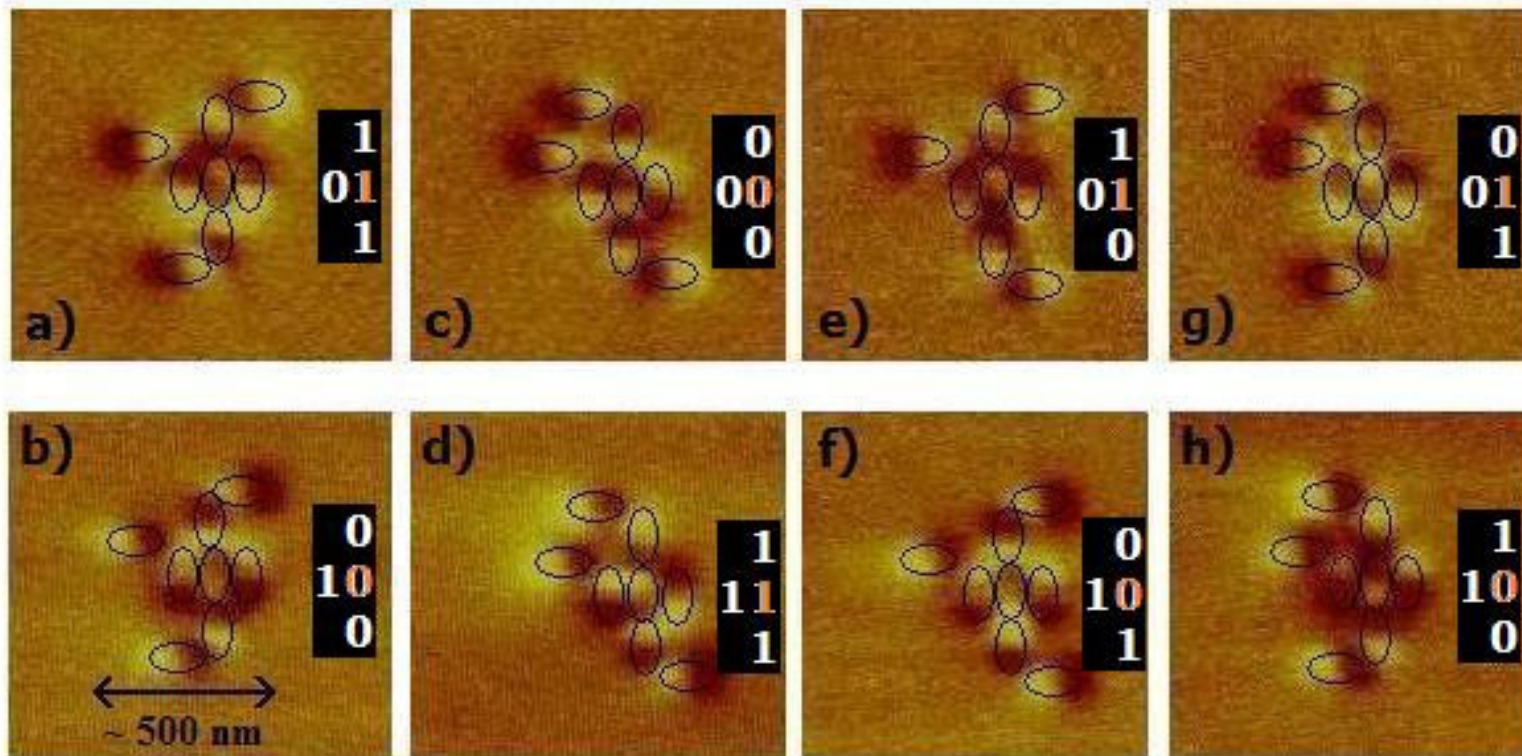
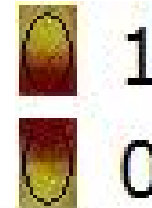

A. Imre *et al*, SCIENCE, VOL. 311, 205 (2006)

# Proposed Implementation and Drive Circuitry

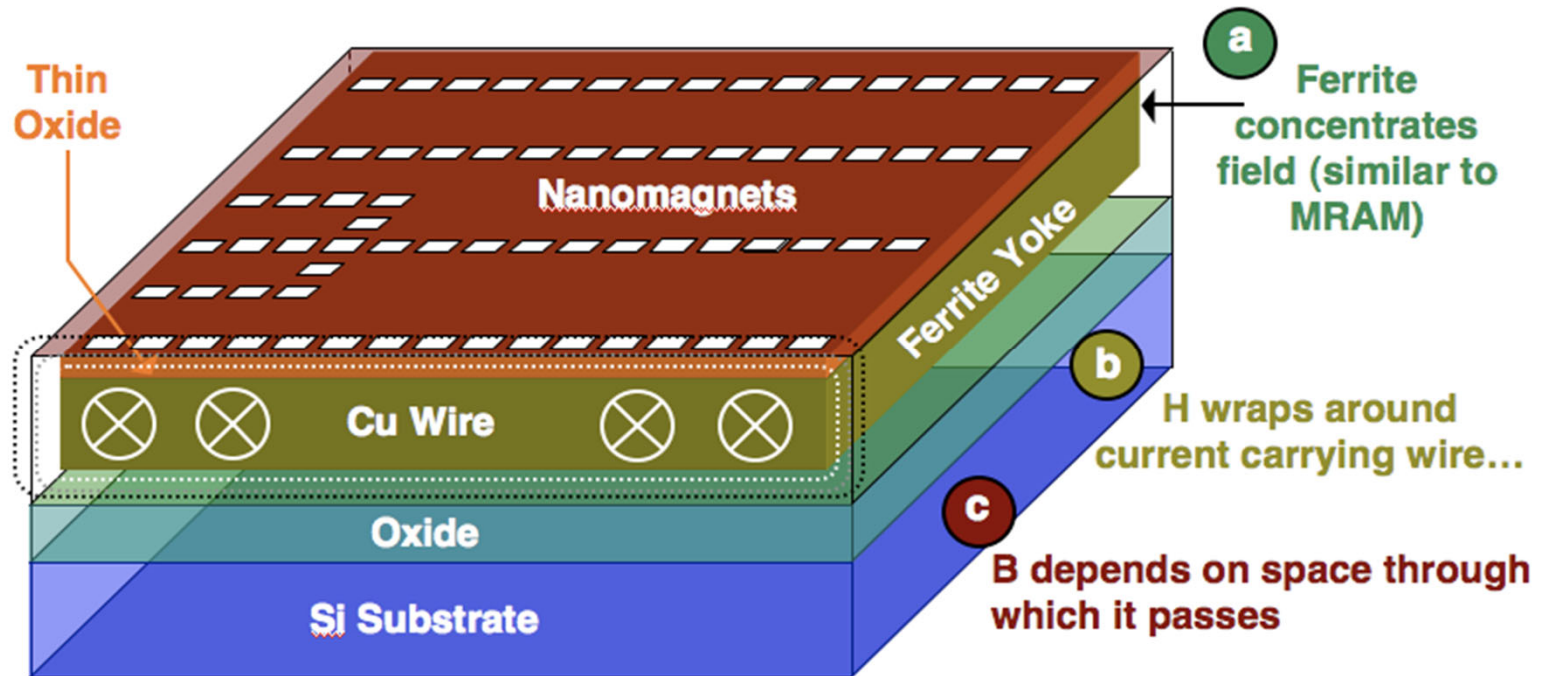

1 wire controls 1000s of magnets

# QCA: advantages vs. issues/challenges

## Key advantages:

- Only the adjacent cells interact: **no interconnects**
- The inputs & output placed exclusively at the periphery: **functionality defined by inter-cell propagation**
- computation corresponds to the **relaxation of the system toward a stable (equilibrium) state**
- Ultra low power consumption: **Power x delay ~ kT**

## Issues/challenges:

- very small dimensions, highly compact: **dots < 20nm**
- demonstrators only @ cryogenic temperatures : **T < 1K**
- **technology: not yet mature. Magnetic QCA?**
- intrinsic problem of **reverse propagation** (bi-directional) :  
output → input (input → output)
- needs implementation of **clock for practical operation** and power gain.