



Pumped storage hydropower



Prof. Fabrizio Sossan, Dr. Stefano Cassano
HES-SO Valais-Wallis

Contents

1. Introduction
2. Layout and modelling of PSH
3. Pumped storage technologies
4. Examples of existing plants
5. References



Introduction

- Pumped Storage Hydropower (PSH) is a type of hydropower that stores and generates electricity by using gravitational potential energy of the water
- At times of low demand and low electricity prices, the water is pumped to the higher reservoir
- At times of high demand and higher prices, the water is then released to drive a turbine in a powerhouse and supply electricity to the grid
- The energy storage capacity of a pumped hydro facility depends on the size of its two reservoirs, while the amount of power generated is linked to the size of the turbine.

PSH operating principle

Pump operation

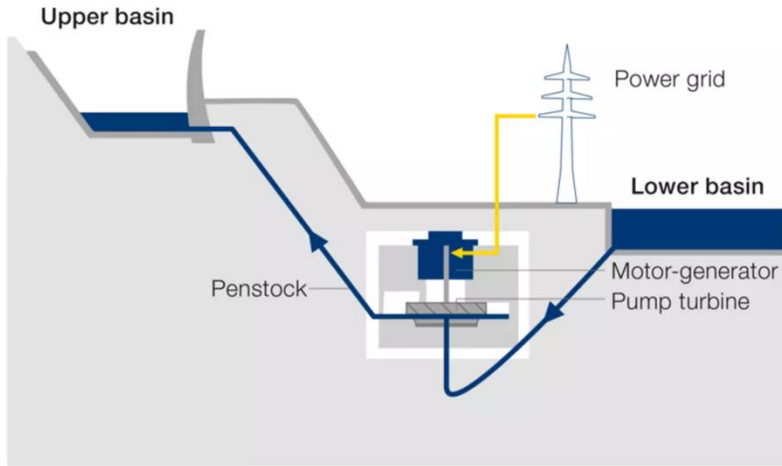

- Power from the grid is used to operate the electric motor
- The electric motor powers the pump turbine
- The water is pumped from the lower basin to the upper basin

Turbine operation

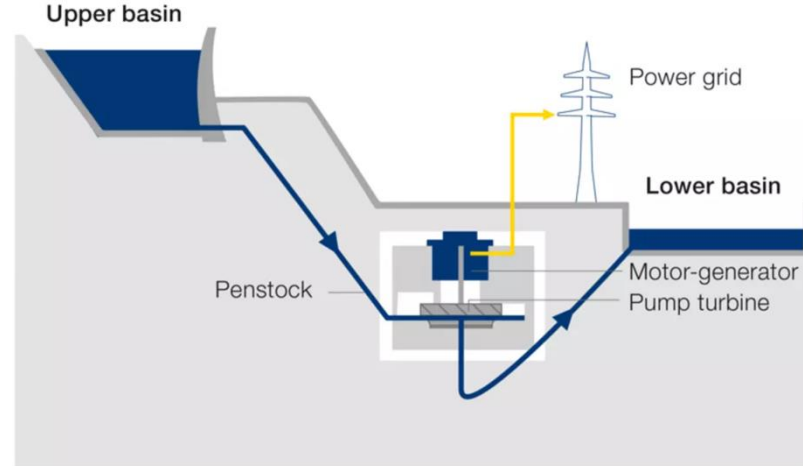

- Water flows from the upper basin through a penstock to the turbine
- The turbine powers the generator, producing electricity for the grid
- The water is discharged into the lower basin.

The role of PSHs in enhancing grid flexibility

- PSHs can help mitigate the variability of renewable energy sources by providing regulating capacity to match power consumption
- Additionally, they balance the load in the system, absorbing energy during off-peak hours and meeting demand in peak times.

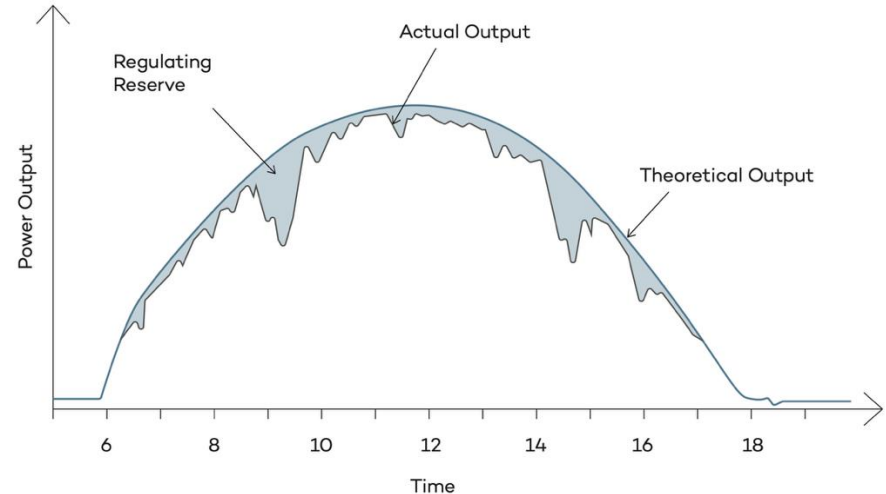
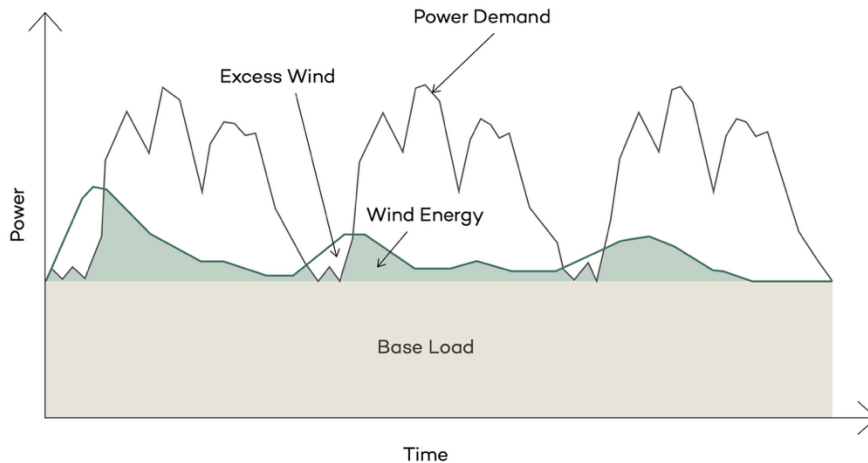

Global pumped storage installed capacity

- In 2024, PSH accounted for over 90% of installed global energy storage capacity and over 92% of energy stored in grid scale applications.
- The total installed capacity is around 179 GW
- PSH storage capacity is expected to increase by 50% to about 240 GW by 2030
- Locations and data for existing and planned PSH projects: [here](#)

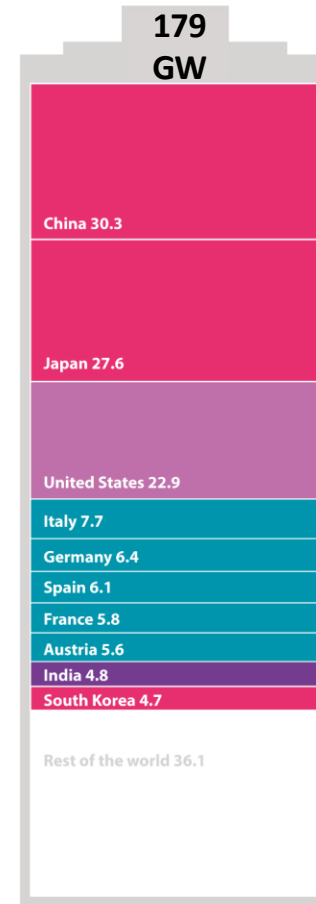

Cumulative installed PSH capacity in Europe in 2023, by country (in MW)

Installed pumped storage capacity in Europe 2023, by country

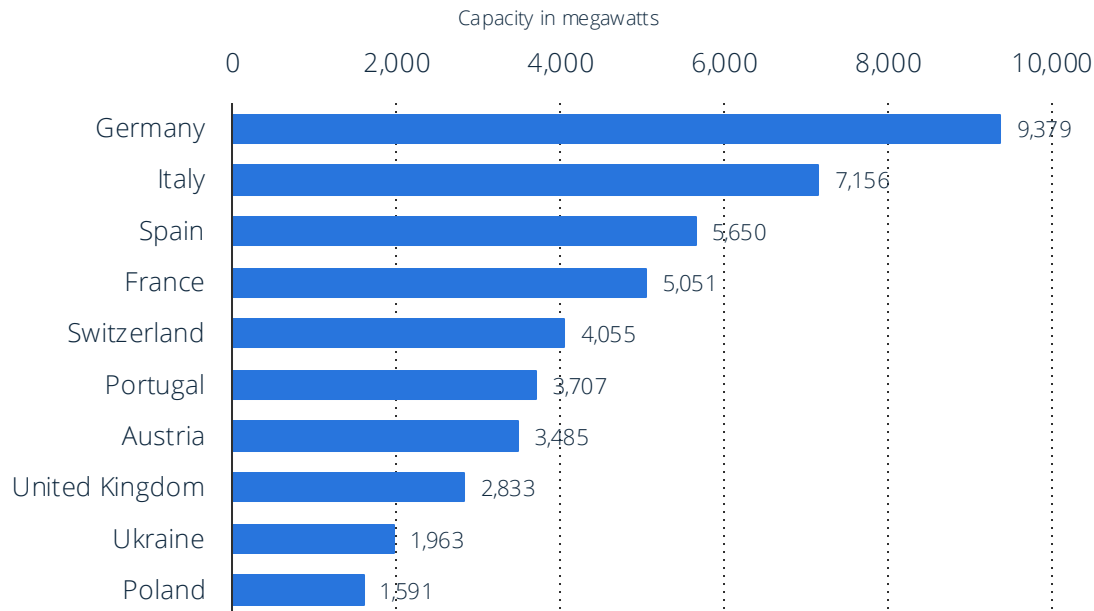

- The EU hosts 46 GW of PHS capacity, which is a quarter of the global installed capacity
- The 1.8 GW Grand' Maison PSH in the French alps is the largest PSH in Europe
- Switzerland is a leader in PSH with several high-capacity plants, including the 900 MW Nant de Drance

Types of pumped-hydro

There are two main types of pumped-hydro:

- **Open-loop:** with either an upper or lower reservoir that is continuously connected to a naturally flowing water source such as a river.
- **Closed-loop:** an 'off-river' site that produces power from water pumped to an upper reservoir without a significant natural inflow

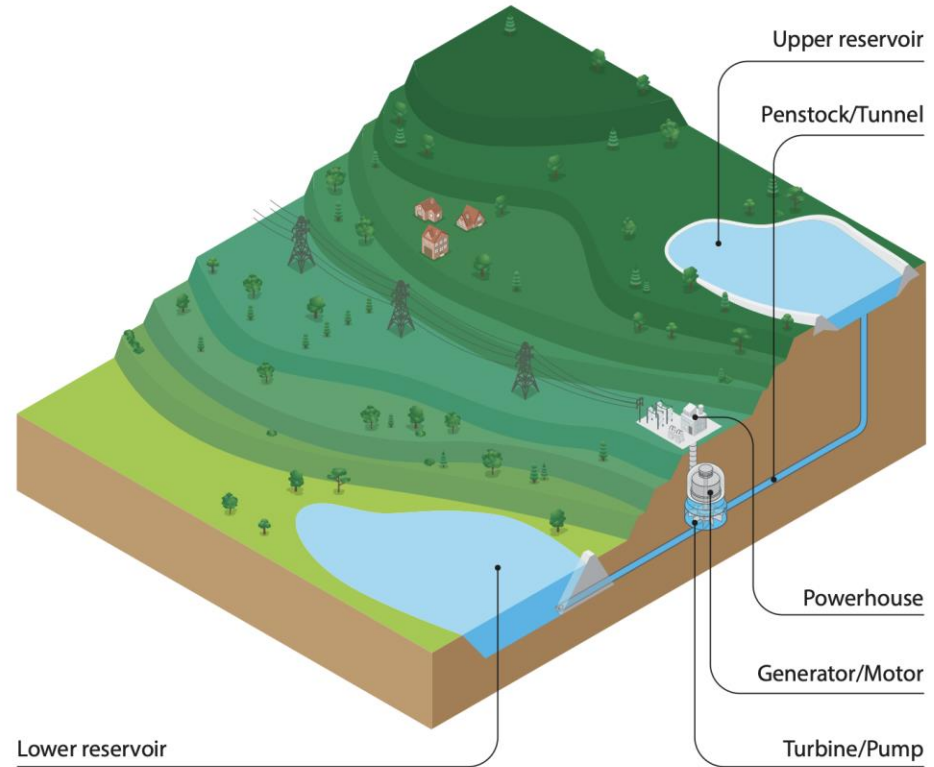

Components of a PSH

The main components of a PSH are:

- **Dam:** a barrier that stops or restricts the flow of surface
- **Reservoir:** an enlarged lake behind a dam built to store water
- **Penstock:** open or closed channel to flow the water from the reservoir to the turbine
- **Surge tank:** cylindrical tank open at the top to control the pressure in penstock
- **Pump/Turbine:** convert the hydraulic energy of the water into the mechanical energy or pump the water upstream
- **Power house:** building provided to protect the hydraulic and electrical equipment such as the generator

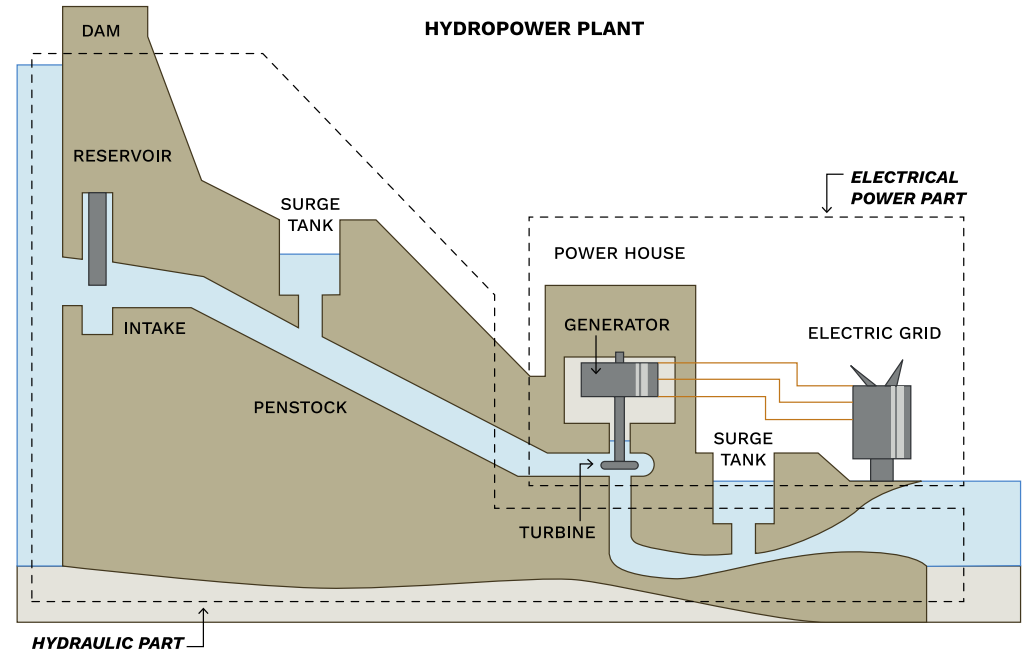

Hydraulic and mechanical quantities

Turbine operation

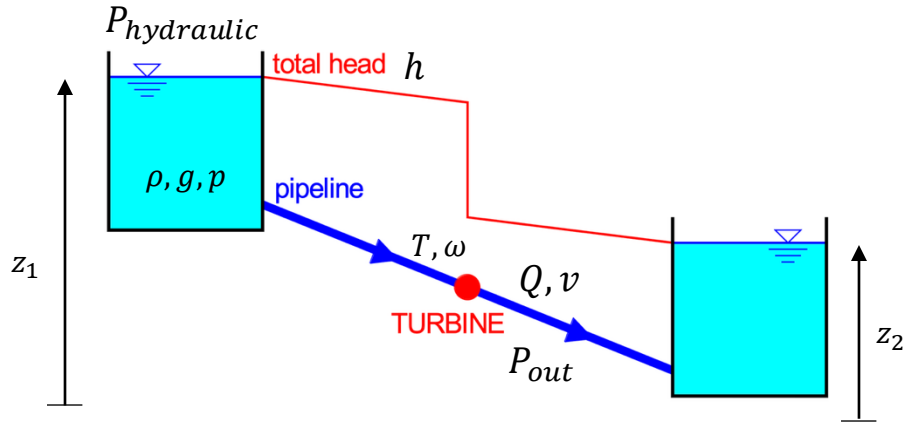

Pump operation

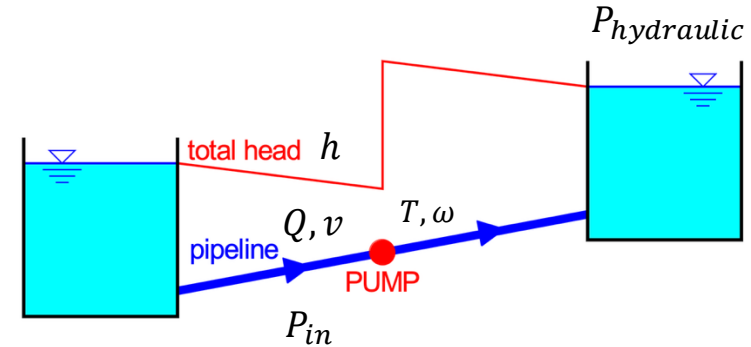

where:

- v is the fluid flow speed [m/s]
- g is the gravity acceleration [m/s²]
- z is the elevation of the point above a reference plane [m]
- p is the pressure at the chosen point [Pa]
- ρ is the density of the fluid at all points in the fluid [kg/m³]
- Q is the flow rate = fluid flow speed x section of the tube [m³/s]
- T is the mechanical torque [Nm]
- ω angular speed [rpm]

Energy conversion

Energy balance (Bernoulli)

$$E_{tot} = E_{pressure} + E_{potential} + E_{kinetic}$$

Pressure energy = work done to lift a fluid column due to pressure

$$E_{pressure} = p \cdot V$$

where V is the volume

Potential energy = energy held by a mass because its elevation

$$E_{potential} = mgz$$

Kinetic energy = energy held by a mass due to its motion

$$E_{kinetic} = \frac{1}{2}mv^2$$

In terms of **Head, h** (energy per unit weight = E/mg) in meters:

$$h = \frac{E_{tot}}{mg} = \frac{p}{\rho g} + z + \frac{v^2}{2g}$$

Pressure head

Elevation head

Velocity head

Power in turbine and pump modes

Hydraulic power = Energy / time

$$P_{hydraulic} = \frac{E_{tot}}{t} = \frac{m}{t}gh = \rho gQh$$

where $\frac{m}{t} = \rho Q \left[\frac{kg}{m^3} \cdot \frac{m^3}{t} \right]$

Power balance in turbine mode:

$$P_{hydraulic} = P_{electric} + P_{losses} = P_{electrical} + P_{penstock,loss} + P_{turbine,loss} + P_{generator,loss}$$

Power balance in pump mode:

$$P_{hydraulic} = P_{electric} + P_{losses} = P_{electrical} + P_{penstock,loss} + P_{pump,loss} + P_{motor,loss}$$

Efficiency in turbine and pump modes

Overall efficiency in turbine mode, η :

$$\eta = \frac{P_{electric}}{P_{hydraulic}} = 1 - \frac{P_{losses}}{\rho g Q h} = \eta_{penstock} \cdot \eta_{turbine} \cdot \eta_{generator}$$

Overall efficiency in pump mode, η :

$$\eta = \frac{P_{ydraulic}}{P_{electric}} = 1 - \frac{\rho g Q h}{P_{losses}} = \eta_{penstock} \cdot \eta_{pump} \cdot \eta_{motor}$$

Turbine efficiency,
 $\eta_{turbine}$:

$$\eta_t = \frac{P_{out}}{P_{in}} = \frac{P_{mech}}{\rho g Q h} = \frac{T \cdot \omega}{\rho g Q h}$$

Pump efficiency,
 η_{pump} :

$$\eta_p = \frac{\rho g Q h}{P_{mech}} = \frac{\rho g Q h}{T \cdot \omega}$$

Penstock efficiency,
 $\eta_{penstock}$:

$$\eta_{penstock} = \frac{P_{hydraulic,out}}{P_{hydraulic}}$$

Penstock losses

Head loss h_f due to friction (Darcy-Weisbach equation)

$$h_f = f \cdot \frac{L}{D} \cdot \frac{v^2}{2g}$$

where:

- f is the Darcy friction factor
- D is the penstock's diameter
- L is the penstock's length

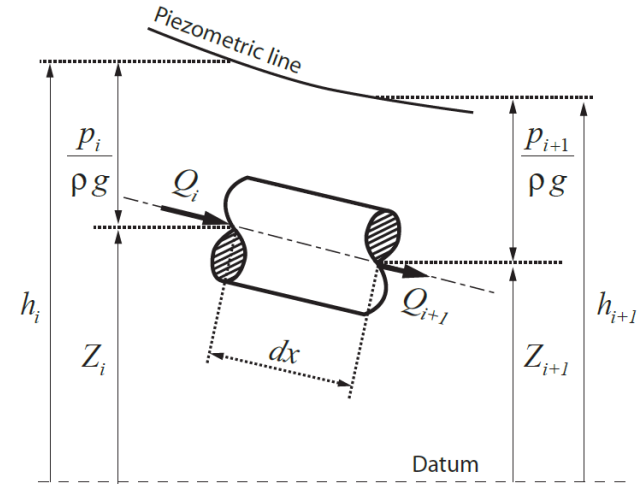

Penstock efficiency, $\eta_{penstock}$:

$$\eta_{penstock} = \frac{P_{hydraulic,out}}{P_{hydraulic}} = \frac{\rho g Q (h - h_f)}{\rho g Q h}$$

Types of hydraulic machines (1/2)

$$h = \frac{p}{\rho g} + z + \frac{v^2}{2g}$$

Impulse turbines:

Fluid's kinetic energy converted to mechanical work at the atmospheric pressure

- Change in velocity → Change in head

Reaction turbines:

Both fluid's kinetic and potential energy is converted to mechanical work

- Change in pressure → Change in head

Types of hydraulic machines (2/2)

The most common hydraulic machines used in hydropower plants are:

- **Pelton turbine** (impulse turbine)
 - very high head
 - nozzle
- **Francis pump-turbine** (reaction turbine)
 - medium head
 - reversible machines
- **Kaplan turbine** (reaction turbine)
 - low head
 - double control system



1-D Modelling of hydraulic circuits (1/2)

The governing equations are the continuity of mass and momentum:

$$\frac{\partial h}{\partial t} + \frac{a^2}{gA} \frac{\partial Q}{\partial x} = 0$$
$$\frac{\partial h}{\partial x} + \frac{1}{gA} \frac{\partial Q}{\partial t} + \underbrace{\frac{f|Q|}{2gA^2D}}_{\text{friction losses}} Q = 0$$

with state variables

h : Head

Q : Volumetric flow rate

parameters and constant

A : Pipe cross-sectional area

D : Pipe internal diameter

f : Friction factor

a : Speed wave (or celerity)

g : Acceleration of gravity

ρ : Water density

1-D Modelling of hydraulic circuits (2/2)

Spatial discretization

$$\left. \frac{\partial h}{\partial x} \right|_{i+\frac{1}{2}} = \frac{h_{i+1} - h_i}{\Delta x}$$

$$\left. \frac{\partial Q}{\partial x} \right|_{i+\frac{1}{2}} = \frac{Q_{i+1} - Q_i}{\Delta x}$$

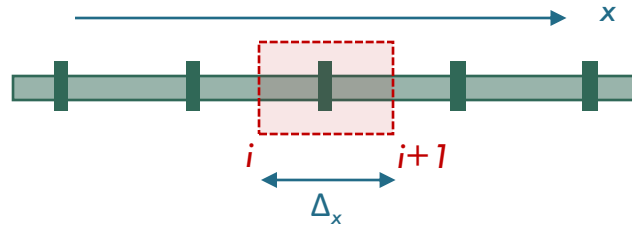

$$\begin{cases} \dot{h}_{i+\frac{1}{2}} = \frac{1}{C}(Q_i - Q_{i+1}) \\ h_{i+\frac{1}{2}} = \frac{L}{2}\dot{Q}_i + \frac{R}{2}Q_{i+1} - h_i \\ h_{i+\frac{1}{2}} = \frac{L}{2}\dot{Q}_{i+1} + \frac{R}{2}Q_{i+1} + h_{i+1} \end{cases}$$

where:

$$C \triangleq \frac{gA}{a^2} \Delta x$$

$$L \triangleq \frac{1}{gA} \Delta x$$

$$R(Q) \triangleq \frac{\lambda|Q|}{2gA^2D} \Delta x$$

Electrical equivalent circuit

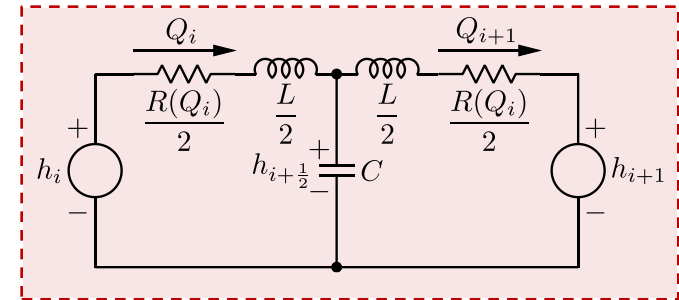

1-D Modelling of hydraulic machines (1/2)

- **Quasi-static model:** The transient behavior of the hydraulic machines can be simulated as a succession of different steady-state operating points
- **Characteristic curves:** capture the relation between the machine state variables (e.g., specific energy (gh), torque, rotational speed, flow, guide vane opening)

1-D Modelling of hydraulic machines (2/2)

To display the characteristic curves it is convenient to eliminate one of the state by means of the **hydraulic machine similitude laws**:

$$N_{11} = \frac{N \cdot D_{ref}}{\sqrt{(E/g)}} \quad ; \quad Q_{11} = \frac{Q}{D_{ref}^2 \cdot \sqrt{(E/g)}} \quad ; \quad T_{11} = \frac{T}{D_{ref}^3 \cdot E/g}$$

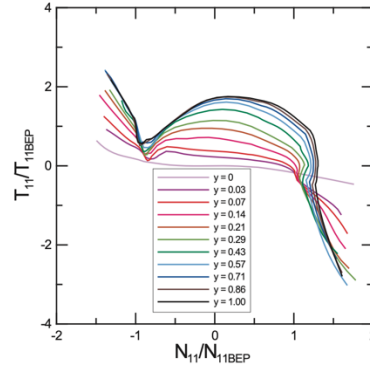
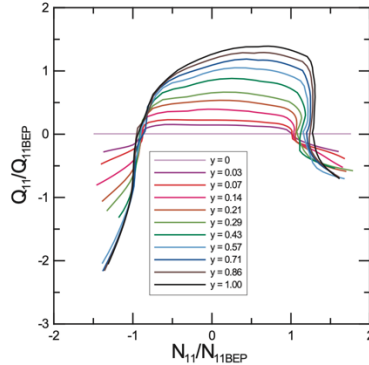

Volumetric flow (left) and torque (right) characteristic curves of a Francis pump/turbine



The S-shape between the 1st and 4th quadrant leads to numerical troubles for the numerical tractability



Polar representation

Polar representation of a Francis machine

The **pressure source H** of the model is directly driven from the turbine characteristic $W_H(y, \theta(Q, N))$:

$$W_H(\theta) = \frac{H/H_{BEP}}{(Q/Q_{BEP})^2 + (N/N_{BEP})^2} \longrightarrow \text{Best Efficiency Point}$$

The **mechanical torque T** of the pump-turbine is obtained from the torque characteristic $W_B(y, \theta(Q, N))$:

$$W_B(\theta) = W_H(\theta) \cdot \frac{T_{11}}{T_{11BEP}} = \frac{T/T_{BEP}}{(Q/Q_{BEP})^2 + (N/N_{BEP})^2}$$

The **turbine rotational speed ω** is according to the momentum equation applied to the rotational inertias:

$$J \cdot \frac{d\omega}{dt} = \sum T_{ext} = T_{turb} - T_{elect}$$

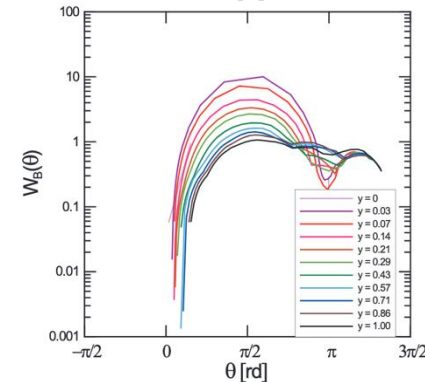
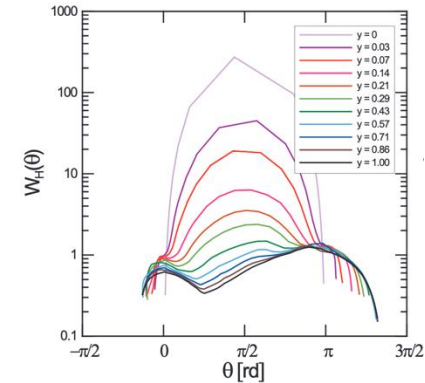

Polar representation

Equivalent circuit model of hydropower plants

Equivalent circuit model (ECM) of the complete plant obtained by combining the penstock model, turbine model, and reservoirs

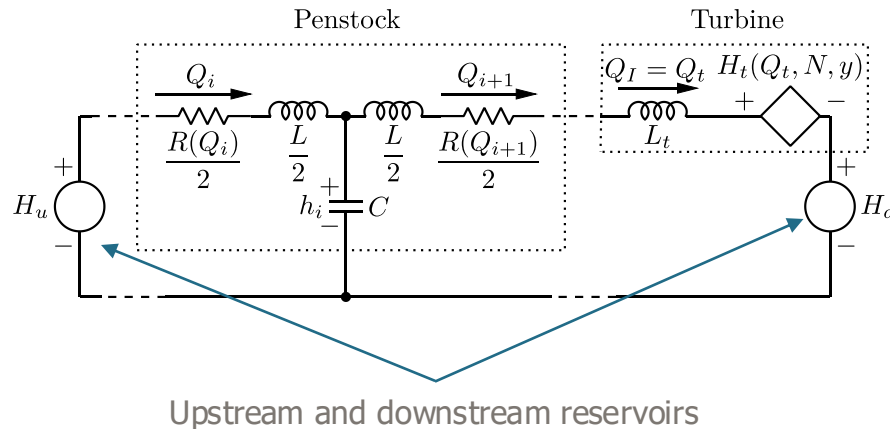

State-space representation

Equivalent circuit model



State-Space representation

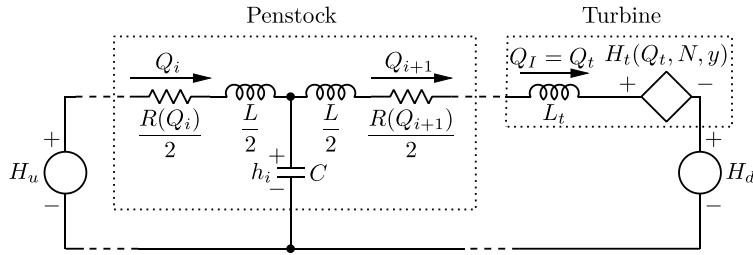

$$\dot{X} = A \cdot X + B \cdot u$$

$$\dot{X} = \begin{bmatrix} -R & 0 & -1 & 0 \\ \frac{1}{L} & -R & \frac{1}{L} & 0 \\ \frac{1}{c} & -\frac{1}{c} & \frac{1}{L} & 0 \\ 0 & 0 & 0 & 0 \end{bmatrix} \begin{bmatrix} Q_1 \\ Q_2 \\ H_c \\ \omega \end{bmatrix} + \begin{bmatrix} \frac{1}{L} & 0 & 0 \\ 0 & \frac{-1}{L} & 0 \\ 0 & 0 & \frac{1}{J} \end{bmatrix} \begin{bmatrix} H_u \\ H_t - H_d \\ T_t + T_{el} \end{bmatrix}$$



H_t and T_t are obtained from W_H and W_B from the polar representation



Numerical integration: Runge-Kutta 4th order

Pumped storage technologies

The pumped storage technologies can be grouped into three categories:

1. Conventional PSH
2. Tertiary set PSH
3. Variable-speed PSH

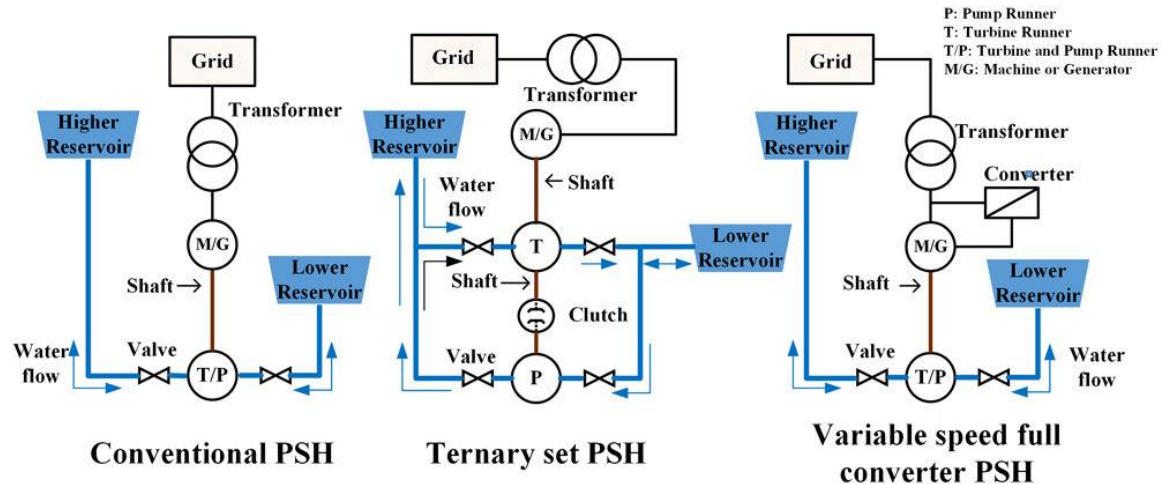

Conventional PSH

Typical layout consists in:

1. install two separate aggregates, one pump and one turbine, or
2. use a machine that runs both ways (reversible pump turbines (RPTs))

PSH are characterized by:

- long lifetime expectancy (typically between 50 and 100 years)
- a round-trip efficiency of 70–80%
- fast response time in the order of seconds or minutes.

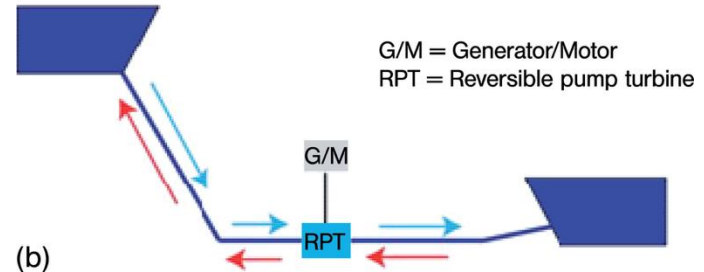
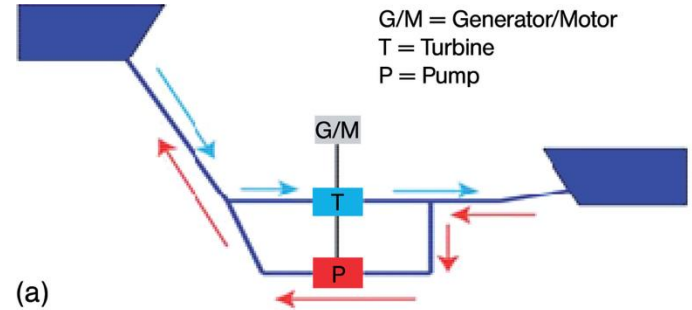

Tertiary set PSH

Tertiary set consist of a motor-generator, a separate turbine (e.g., Francis or Pelton) and a pump set

Typical layout consists in:

1. vertical shaft and the motor-generator located between the turbine and the pumps
2. motor-generator located at the top, above both the turbine and the pump

A **clutch** is inserted on the shaft above the pump to disconnect the pump during turbine operation to avoid ventilation losses in the pump

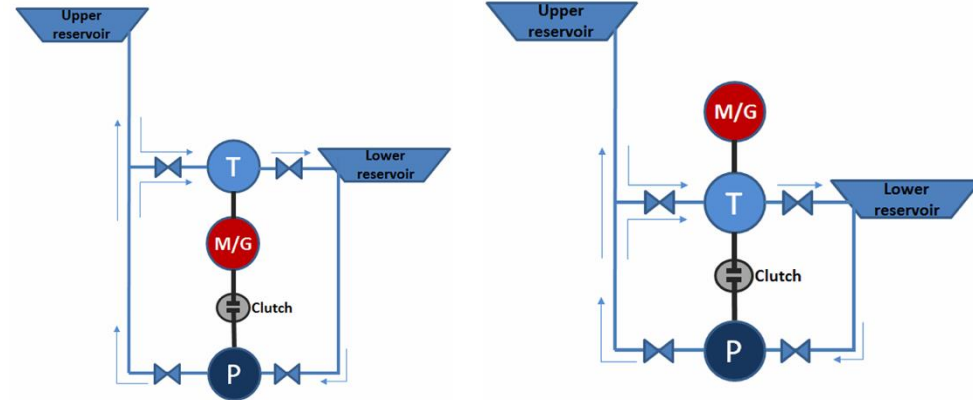

Operating modes of tertiary units

- **Generating mode:** the guide vanes to the pump are closed and the clutch is not engaged. The amount of generation is controlled by the position of the turbine guide vanes.
- **Pumping mode:** the guide vanes to the turbine are closed and the clutch is enabled. The pump guide vanes are wide open and there is no regulation capability.
- **Pumping/generating mode:** the clutch is enabled and both the pump and the turbine operate

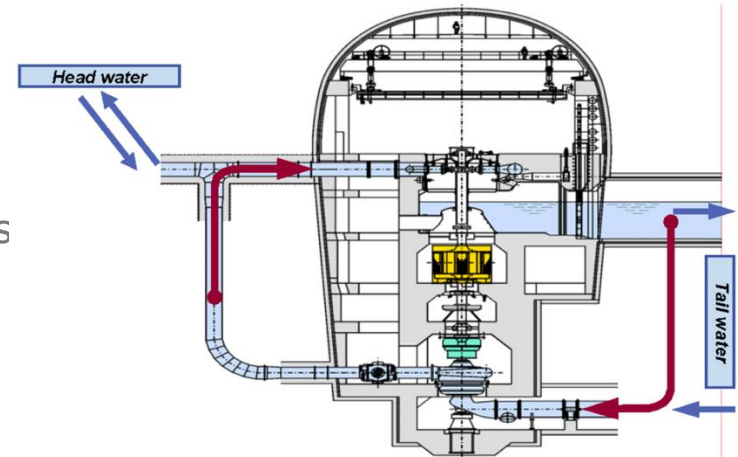

This is referred to as a “**hydraulic short circuit**”

Hydraulic short circuit

Example of operation in pumping mode with regulation capability using the Hydraulic Short-Circuit concept

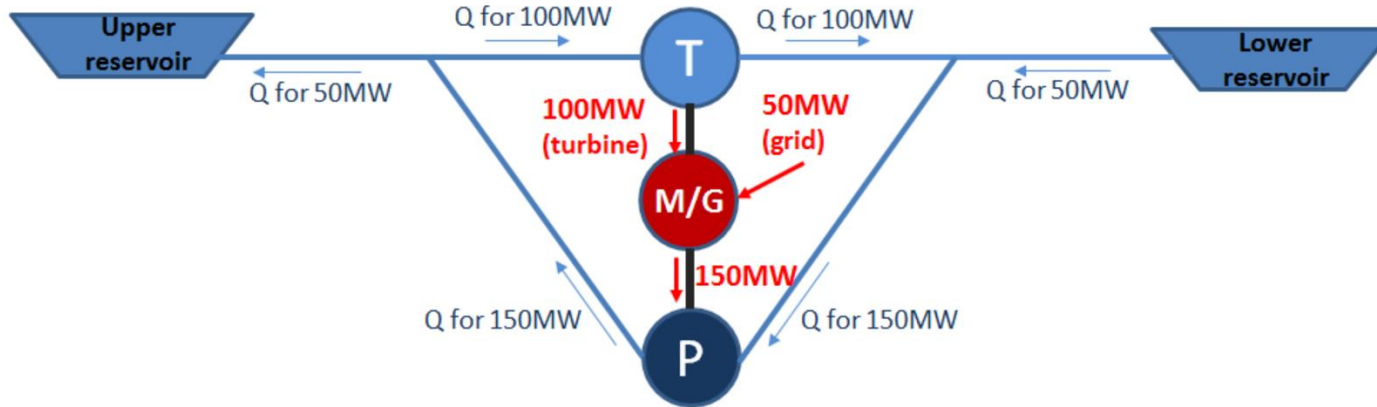

- The power applied to the shaft from the pump is 150 MW drawn from the power system
- The turbine guide vanes are adjusted so that the turbine supplies 100 MW to the power system
- The net result is that 50 MW is drawn from the power system, and the flow pumped up to the reservoir is equivalent to 50 MW

Advantages of tertiary units

Main advantages:

- Ternary plant can simultaneously operate both the pump and turbine
- The shaft rotates in the same direction in both operational mode reducing hydraulic transients and increasing the time to switch from turbine to pump mode
- Round-trip efficiency of up to 82%

Variable-speed pump turbines

The variable-speed technology allows to decouple the grid and generator frequency

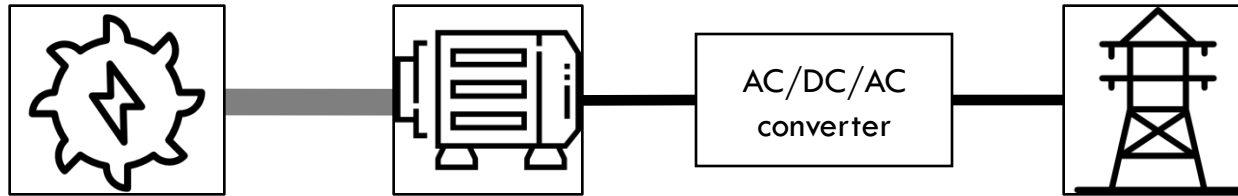

The main procedures adopted to obtain variable speed are:

- Synchronous Generator with back-to-back frequency converter
- Double-Fed Induction Generator (DFIG)

Main Advantage: the recovery of efficiency of the hydraulic turbine (almost to its rated efficiency) when working at a head lower than the design head.

DFIG working principle

- The rotor of the machine is connected to the machine's terminal through a power converter
- The power converter can control the voltage, current and frequency in the rotor circuit
- The DFIG rotor must be excited with a complement frequency to achieve the rated frequency in the stator generated voltage

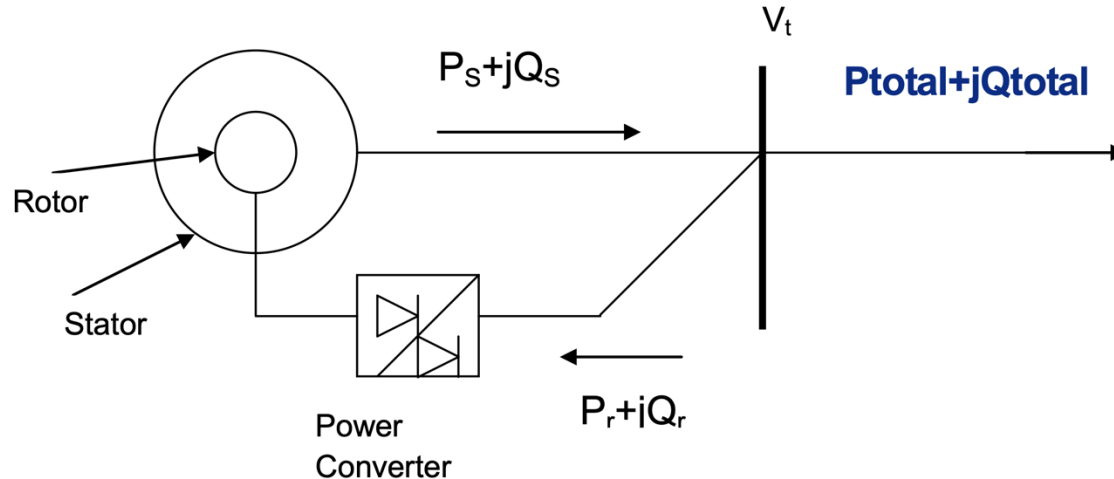

Grand' Maison PSH, France

- **Nominal power:** 1.8 GW with 4x 158.5 MW multi-jet Pelton turbines and 8x 154MW Francis pump-turbines
- **Energy capacity:** 1420 GWh
- **Storage capacity:** 137 millions of m³ of water in the upper reservoir
- **Gross head:** 918 m
- **Technologies tested:** Hydraulic short circuit



Nant de Drance PSH, Switzerland

- **Nominal power:** 900 MW with 6x150 MW Francis pump-turbines
- **Energy capacity:** 200 GWh
- **Storage capacity:** 25 millions of m³ of water in the upper reservoir
- **Turbine to pump switching time:** less than 5 minutes
- **Net head:** 71.1 m



References

- [1] Pumped Storage Systems reliable & economical, afry.com
- [2] International Hydropower Association (IHA), hydropower.org/statusreport
- [3] International Hydropower Association; ID 690032
- [4] Enabling new pumped storage hydropower: A guidance note for key decision makers to de-risk pumped storage investments, hydropower.org/publications
- [5] C. Nicolet, "Hydroacoustic modelling and numerical simulation of unsteady operation of hydroelectric systems"
- [6] S. Cassano and F. Sossan, "Stress-informed control of medium- and high-head hydropower plants to reduce penstock fatigue"
- [7] Z. Dong et al., "Modeling and Simulation of Ternary Pumped Storage Hydropower for Power System Studies"
- [8] A. Harby et al., "Pumped Storage Hydropower"
- [9] Modeling Ternary Pumped Storage Units, ceesa.es.anl.gov/projects
- [10] Modeling Adjustable Speed Pumped Storage Hydro Units Employing Double-Fed Induction Machines, ceesa.es.anl.gov/projects
- [11] XFLEX HYDRO, xflexhydro.com/test-sites/grand-maison
- [12] Nant de Drance website: <https://www.nant-de-drance.ch>

To do

1 cluch disaccoppiamento

2 turbine

3 set up grand maison

4 tutte le tecnologie disponibili

5 esercizio in matlab: didattico per spiegare bene le basi metodologiche: trovare la Potenza a partire dalla discharge etc (come il mio modello)

6 definizione di energia

7 efficienza? numeri