	Author(s) Name(s) Amin Darvishzadeh, Celia Hermoso Diaz	Function Teaching Assistants
	Professor Name Dražen Dujčić	Date of Release 12.10.2025
Title EXERCISE 5: THREE-PHASE INVERTER, CBPWM		
Course Name EE-465 Industrial Electronics I		

1 INTRODUCTION

A three-phase 2L inverter (see Fig. 1) is connected to the 3ph grid ($V_{RMS,L-L} = 400\text{ V}$, 50 Hz) through a RL filter. By appropriately setting the phase and magnitude of the voltage synthesized by the inverter, the power exchange with the AC grid can be modified or set. For this exercise, the control is in open loop.

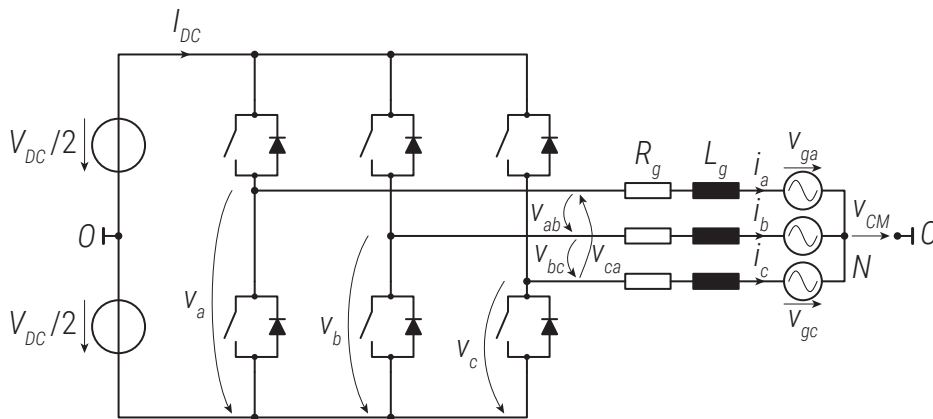

Fig. 1 PV system output stage. The input stage has been replaced by an equivalent voltage source.

2 TASKS DESCRIPTION

- Create a carrier based PWM (CB-PWM) block following the implementation steps presented during the lecture according to the following steps/subsystems:
 - In order to allow good controllability of inductor current and output voltage, the converter needs to be able to synthesise at least 130 % of grid voltage. Determine the DC-link voltage which would enable this capability.
 - What is the maximum output voltage the converter can generate? Determine the modulation index so that the converter output voltage has the same magnitude of the grid voltage. This will depend on your chosen DC-link voltage.
Hint: add V_{in} as initialization parameter in the skeleton, $V_{in} = V_{DC-link}$
 - Create a block that compares a triangular wave with a reference sinusoid. Take into account the reference normalization. Use the resulting PWM signals to drive the converter switches.
 - What happens if modulation index is larger than 1. Observe the grid current. What do you notice?
 - What do you need to modify in order to approach six-step modulation? Make the change and observe the current waveform.
- Using the CB-PWM the maximum output voltage is limited in a way. In order to overcome this limitation you will implement third harmonic injection and min/max injection
 - What is the optimum value of third harmonic magnitude to be added
 - Determine the maximum modulation index using third harmonic injection
 - Create a block that adds a third harmonic on top of fundamental reference wave
 - Create a block that implements min/max injection
 - Choose one of zero sequence injection method. Analyze the frequency spectrum of converter variables and show the effects of this method when compared to simple CB-PWM (from Task 1). Perform this comparison for a modulation index that you consider relevant, and explain why you chose it.
Hint: you can use the Fourier function of PLECS scope