

2. Common-Source Amplifier with a Diode-Connected MOS Load

Parameters: $\mu_n C_{ox} = 278 \mu A/V^2$, $V_{TH,N} = 0.4V$, $\mu_p C_{ox} = 61 \mu A/V^2$, $|V_{TH,P}| = 0.54V$, $V_{DD} = 1.8V$

Operating Points: $V_{IN,DC} = 0.9V$, $V_{OUT,DC} = 0.9V$, $I_D = 10 \mu A$

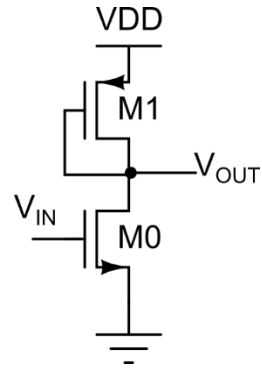

- a. To arrive at the sizing for M1, we note that

$$V_{DD} - V_{OUT,DC} = V_{SG1}$$

$$V_{SG1} = |V_{THP}| + \sqrt{\frac{2I_D}{\mu_p C_{ox} \left(\frac{W}{L}\right)_1}}$$

$$0.9 = 0.54 + \sqrt{\frac{2 * 10u}{61u * \left(\frac{W}{L}\right)_1}}$$

$$\left(\frac{W}{L}\right)_1 = 2.52$$



Here, we choose the length of the PMOS M1 so that $r_{o1} = r_{o0}$. For this, $L_1 \approx 580n$, and $W_1 \approx 1.47u$. We already know the sizing for the NMOS M0 from problem 1: $L_0 = 1u$ and $W_0 = 310n$.

- b. Now, simulate the circuit in Cadence Virtuoso (as in Problem 1), and annotate the DC operating point. The DC operating point for the circuit is as shown below.

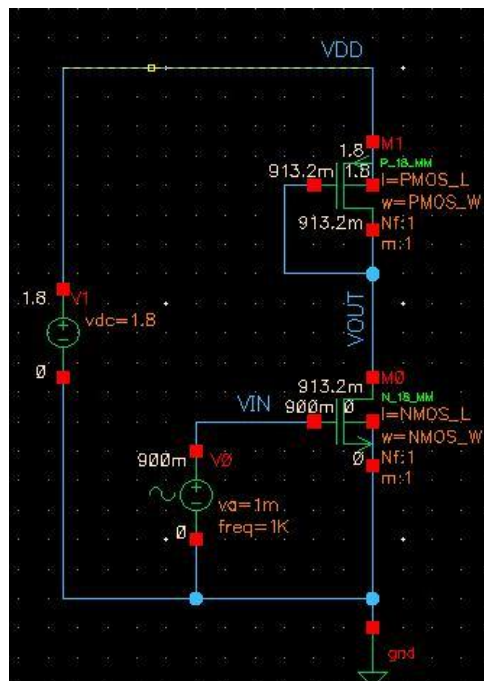

- c. Adjust the “PMOS_L” and “PMOS_W” parameters so that the DC operating point error is less than +/- 0.75%. For example, $L_1 = 580\text{n}$ and $W_1 = 1.4\mu$ seem to work fine for us. You can have any other value that satisfies the operating point conditions.

Now, let us add expressions for g_{m0} , g_{m1} , r_{o0} , r_{o1} (refer to problem 1 or figure below for the expressions or the easier way – do it from the ADE-Explorer Calculator), so that we can calculate the small signal gain of the circuit as,

$$A_v = -g_{m0} \cdot \left(\frac{1}{g_{m1}} \parallel r_{o0} \parallel r_{o1} \right)$$

The screenshot shows the 'Setup' window in ADE-Explorer. On the left, the 'Design Variables' section is highlighted with an orange box, showing parameters: NMOS_L (1u), NMOS_W (310n), PMOS_L (580n), and PMOS_W (1.4u). On the right, a table lists calculated expressions and their values:

Name	Type	Details	Value	Plot
gm0	expr	OP("/M0" "gm")	35.78u	<input checked="" type="checkbox"/>
ro0	expr	OP("/M0" "rout")	1.581M	<input checked="" type="checkbox"/>
ID0	expr	OP("/M0" "ids")	9.942u	<input checked="" type="checkbox"/>
gm1	expr	OP("/M1" "gm")	45.8u	<input checked="" type="checkbox"/>
ro1	expr	OP("/M1" "rout")	1.527M	<input checked="" type="checkbox"/>
ID1	expr	OP("/M1" "ids")	-9.942u	<input checked="" type="checkbox"/>
ro_eff	expr	((ro0 * ro1) / (ro0 + ro1))	776.8K	<input checked="" type="checkbox"/>
rout_eff	expr	(ro_eff / (1 + (gm1 * ro_eff)))	21.24K	<input checked="" type="checkbox"/>
GAIN	expr	((- gm0) * rout_eff)	-760m	<input checked="" type="checkbox"/>

- d. To derive an expression for the voltage gain in terms of the DC operating point,

- $|A_v| = g_{m0} (1/g_{m1} \parallel r_{o0} \parallel r_{o1})$
- $|A_v| = g_{m0}/g_{m1}$ (assuming $r_{o1,2} \gg 1/g_{m1}$). Make sure this is true for you!
- $|A_v| = \frac{2I_{D1}}{|V_{IN} - V_{TH,N}|} \cdot \frac{|V_{OUT} - V_{DD} - V_{TH,P}|}{2I_{D2}}$
- $|A_v| = \frac{|V_{OUT} - V_{DD} - V_{TH,P}|}{|V_{IN} - V_{TH,N}|}$



This shows that, like in the case of a resistive load, the voltage gain is determined once the input and output common modes are fixed. After all, a PMOS diode connected stage is a resistor!

- e. Now, perform the ac simulation and determine the small-signal gain (please refer to problem 1 on how to setup the ac simulation). From the plot, we see that the AC gain closely matches our calculated gain value “GAIN”.

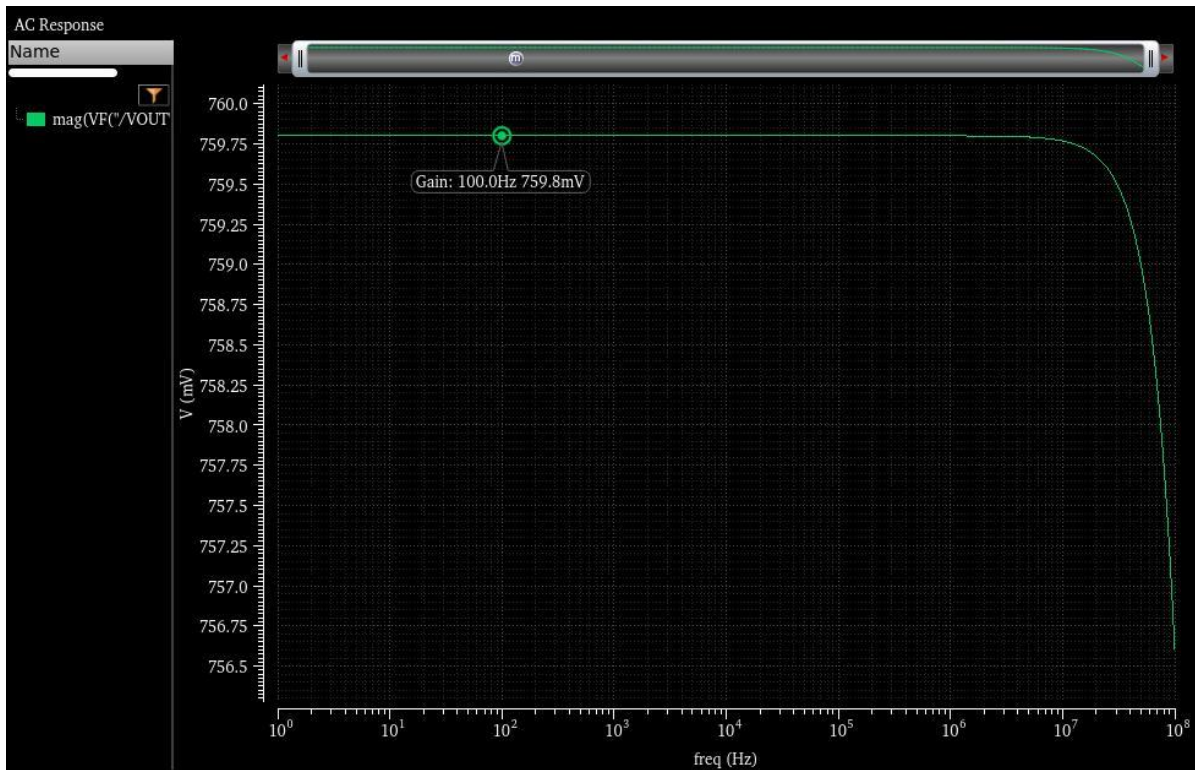

- f. Now, perform the transient simulation and determine the gain (again, please refer to problem 1 to setup the transient simulation)

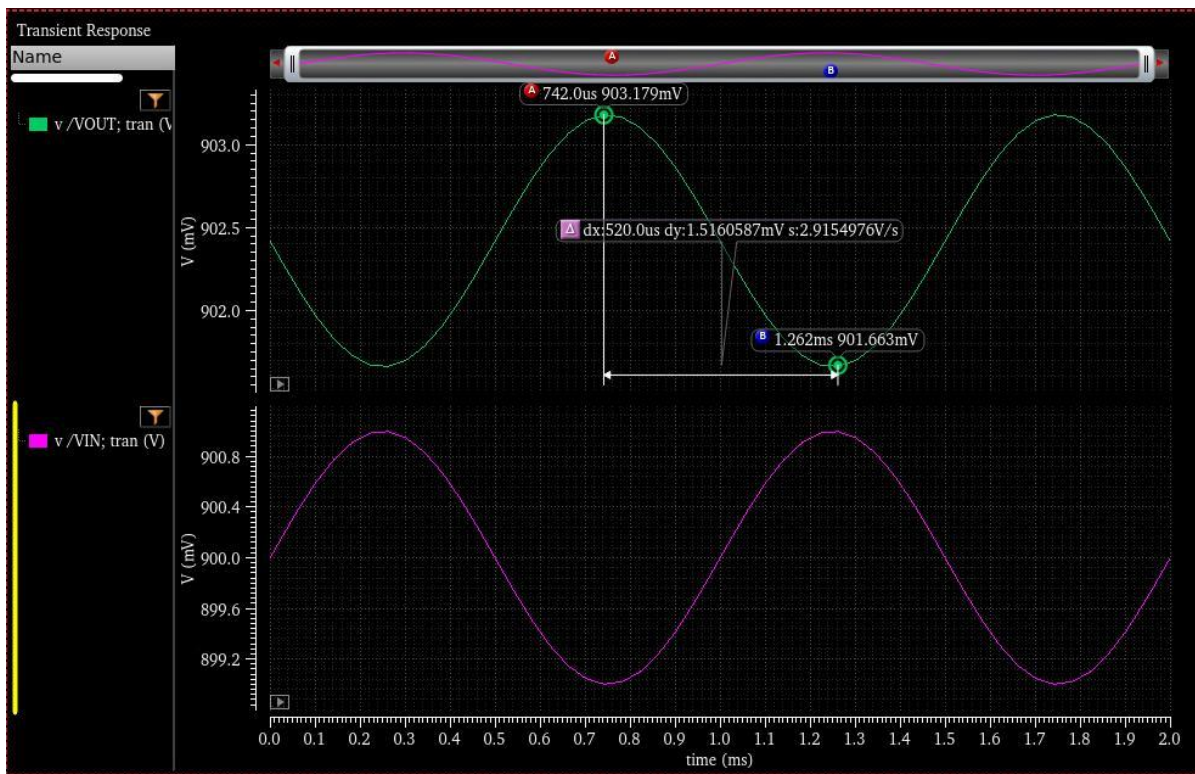

- g. Repeat the procedure for the new operating conditions: $V_{IN,DC} = 0.9V$, $V_{OUT,DC} = 0.6V$, $I_D = 10\mu A$. But, before you begin to do so, ask yourself:



- Based on the analysis in 2 (d), do you expect the gain to increase or decrease?
- Calculate the expected value of gain
- Now, verify the same using simulation



3. Common-Drain (aka Source Follower) Stage

Parameters: $\mu_n C_{ox} = 278 \mu A/V^2$, $V_{TH, N} = 0.4V$, $V_{DD} = 1.8V$

Operating Points: $V_{IN, DC} = 0.9V$, $V_{OUT, DC} = 0.4V$, $I_D = 1 \mu A$, $L = 1 \mu m$

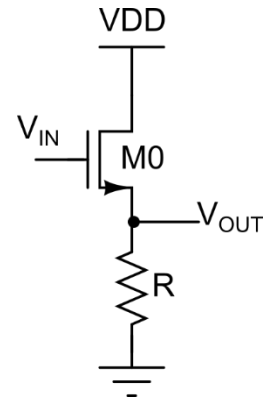

- a. To calculate the value of the resistor R, we note that

$$V_{OUT, DC} = I_D \cdot R$$

$$R = \frac{0.4}{1 \mu} = 400 K \Omega$$

To arrive at the sizing for M0, we note that

$$V_{GS0} = V_{IN, DC} - V_{OUT, DC}$$

$$V_{GS0} = V_{THN} + \sqrt{\frac{2I_D}{\mu_n C_{ox} \left(\frac{W}{L}\right)_1}}$$

$$0.5 = 0.4 + \sqrt{\frac{2 * 1 \mu}{278 \mu * \left(\frac{W}{L}\right)_1}}$$

$$\left(\frac{W}{L}\right)_1 = 0.72$$

As $L_0 = 1 \mu m$, $W_0 = 720 nm$

- b. Now simulate the circuit in Cadence Virtuoso (as in Problem 1) and annotate the DC operating point. The DC operating point for the circuit is shown below.

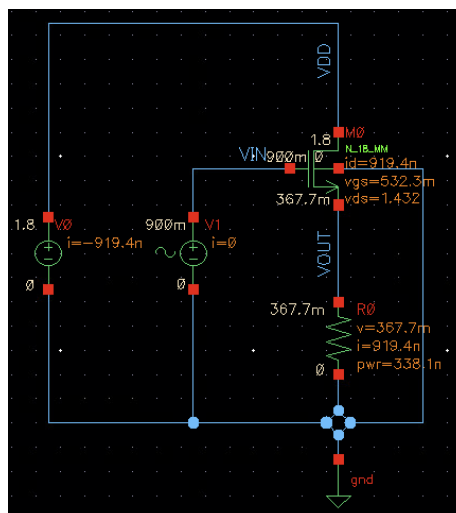

- c. Adjust the “NMOS_W” parameter so that the error is within +/- 0.75%. For example, $W_0 = 1.35\mu$ seems to work fine for us.
- d. The small signal gain for the source follower can be written as (please refer to the course slides – Lecture 5, Page 17 for the expression),

$$A_v = -g_{m0} \cdot \frac{R}{1 + (g_{m0} + g_{mb0}) \cdot R}$$

We need to add expressions for gm, gmb, R, and GAIN in the **Output Setup** palette of the ADE-Explorer as shown below.

The screenshot shows the ADE-Explorer interface. On the left, the 'Design Variables' section is highlighted with an orange box, showing:

Name	Value
NMOS_L	1u
NMOS_W	1.35u
R	400K

On the right, the 'Output Setup' table is shown with the 'GAIN' variable highlighted in orange:

Name	Type	Details	Value	Plot
id	expr	OP("/M0" "id")	1.001u	<input checked="" type="checkbox"/>
gm	expr	OP("/M0" "gm")	18.76u	<input checked="" type="checkbox"/>
gmb	expr	OP("/M0" "gmb")	3.025u	<input checked="" type="checkbox"/>
R	expr	VAR("R")	400K	<input checked="" type="checkbox"/>
GAIN	expr	((gm * R) / (1 + ((gm + gmb) * R)))	772.5m	<input checked="" type="checkbox"/>

- e. Now, perform the ac simulation and determine the gain (please refer to problem 1 on how to setup the ac simulation). From the plot, we see that the AC gain closely matches our calculated gain value “GAIN” (we attribute the resulting error to ignoring r_o in our gain calculation)

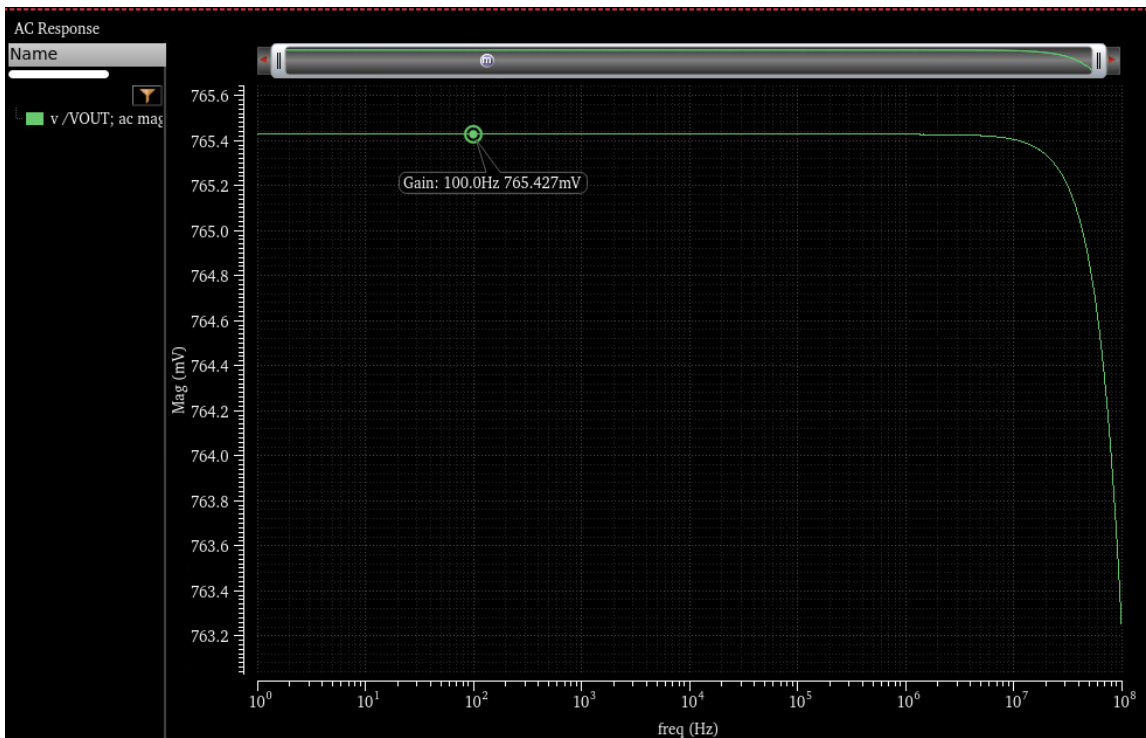

- f. Now, perform the transient simulation and determine the gain (again, please refer to problem 1 to setup the transient simulation)

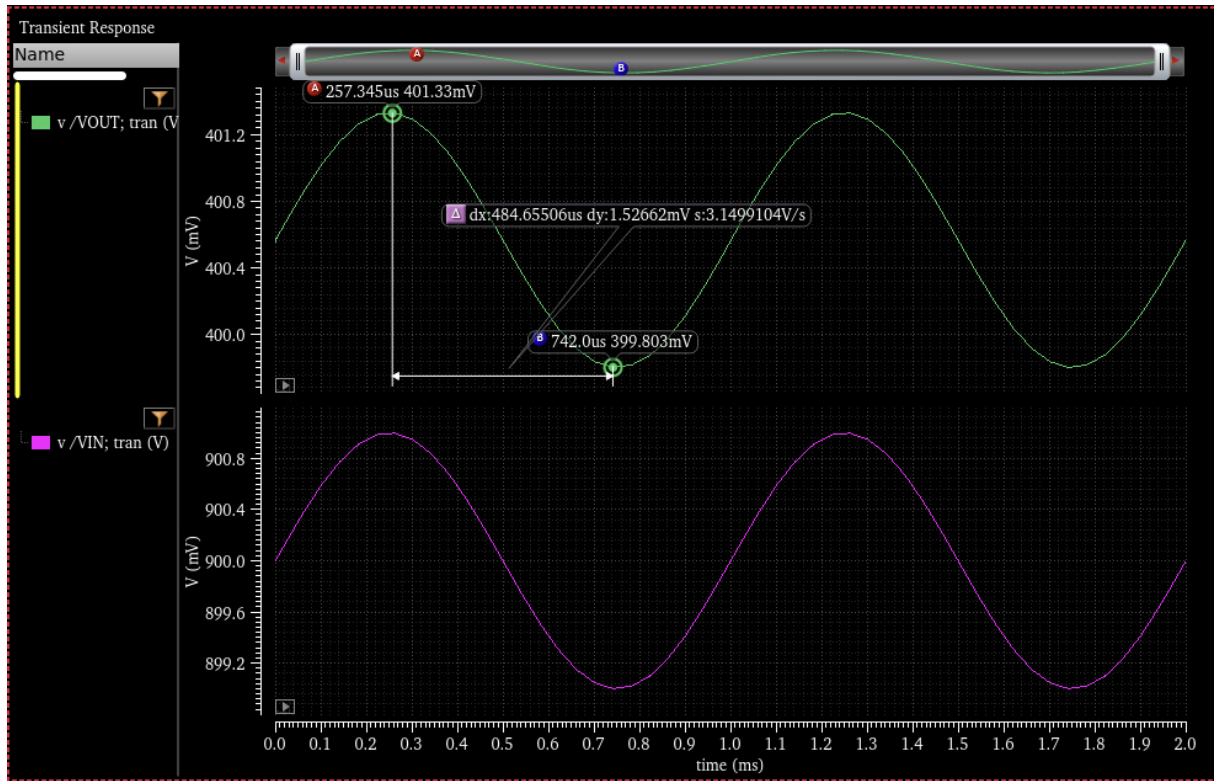

- g. You can derive an expression for the output impedance of the source follower in terms of g_m , g_{mb} , r_o , and R (if in doubt, please refer to the course slides – Lecture 5, Page 22)

$$R_{out} = \frac{1}{g_m + g_{mb}} \parallel r_o \parallel R$$

Add the above expression for R_{out} along with the other expressions in the **Output Setup** palette in ADE-Explorer.

The screenshot shows the 'Setup' window in ADE-Explorer. On the left, the 'Design Variables' section is highlighted with an orange box, showing parameters: NMOS_L (1u), NMOS_W (1.35u), and R (400K). On the right, a table lists various expressions and their values:

Name	Type	Details	Value	Plot
id	expr	OP("/MO" "id")	1.001u	<input checked="" type="checkbox"/>
gm	expr	OP("/MO" "gm")	18.76u	<input checked="" type="checkbox"/>
gmb	expr	OP("/MO" "gmb")	3.025u	<input checked="" type="checkbox"/>
R	expr	VAR("R")	400K	<input checked="" type="checkbox"/>
GAIN	expr	((gm * R) / (1 + ((gm + gmb) * R)))	772.5m	<input checked="" type="checkbox"/>
ro	expr	OP("/MO" "rout")	4.443M	<input checked="" type="checkbox"/>
Zm_eff	expr	(1 / (gm + gmb))	45.9K	<input checked="" type="checkbox"/>
R_eff	expr	((ro * R) / (ro + R))	367K	<input checked="" type="checkbox"/>
Rout	expr	((Zm_eff * R_eff) / (Zm_eff + R_eff))	40.79K	<input checked="" type="checkbox"/>

- h. As described in the problem statement, set the AC magnitude of the input voltage source V0 to 0, and add a current source I1 (with the AC magnitude set to 1) between the output “VOUT” and ground. Now, run the ac simulation and plot VOUT (as mentioned in the problem, we are measuring the output impedance R_{out} as $V_{OUT} = I_1 \cdot R_{out}$ and $I_1 = 1$)

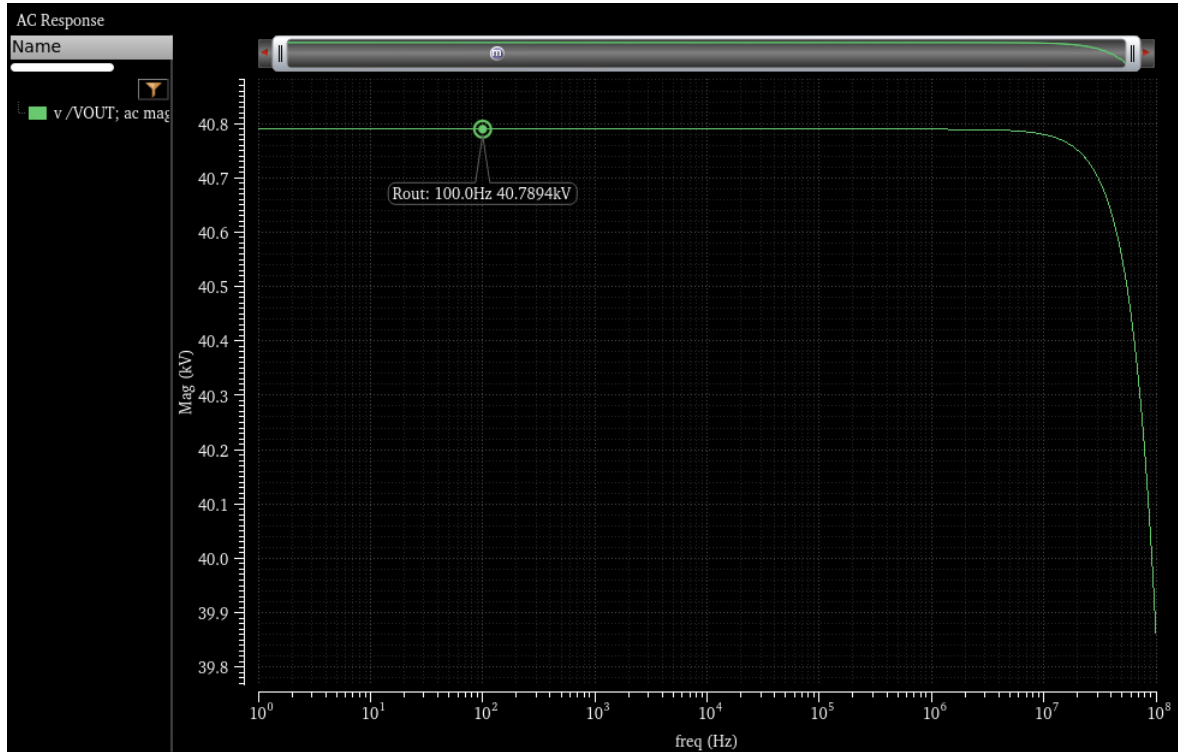

As we can see from the plot, the calculated R_{out} very closely matches the simulated value for the small-signal output impedance.

- i. Repeat the procedure for the new operating conditions: $V_{IN,DC} = 0.9V$, $V_{OUT,DC} = 0.4V$, $I_D = 10\mu A$. But, before you begin to do so, ask yourself:



- Do you expect the gain to increase or decrease?
- Do you expect the output impedance to increase or decrease?
- Now, simulate and verify

