

CS-472: Design Technologies for Integrated Systems

Exercise Problem Set 5

Date: 30/10/2025

Topic: Resource sharing (cf. slide set 6), two-level logic synthesis (cf. slide set 7)

Problem 1

Consider the following set of scheduled operations.

operation ID	latency	start time	resource type
1	1	1	ALU
2	2	1	ALU
3	4	2	ALU
4	3	2	ALU
5	2	5	ALU
6	2	2	ALU
7	3	6	ALU
8	4	5	ALU
9	2	4	ALU

- Draw the interval and conflict graphs.
- Determine the minimum number of ALUs needed using the left-edge algorithm. Show the coloring in both interval and conflict graphs.

Problem 2

Given the function $F = \bar{a}d + ac + a\bar{b}\bar{c}$

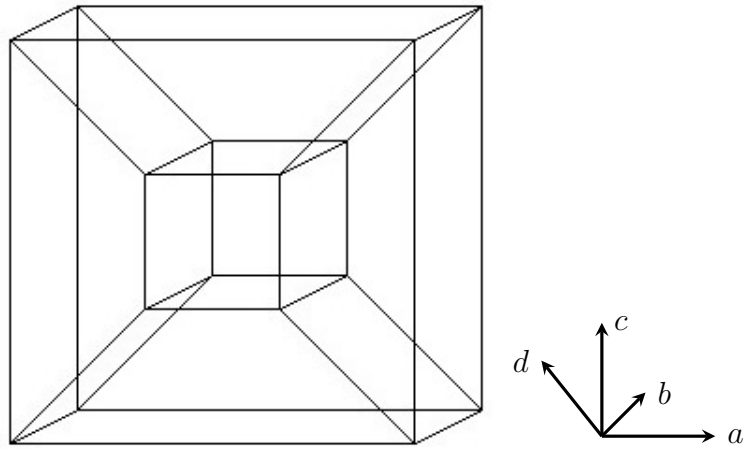

- (a) Draw the minterms on the cube
- (b) Use the cube to show if the following cubes are contained in F :
- cd
 - ad

Problem 3

Given the function $F = \bar{a}b\bar{c} + a\bar{c}d + \bar{a}cd + ac\bar{d} + bd$

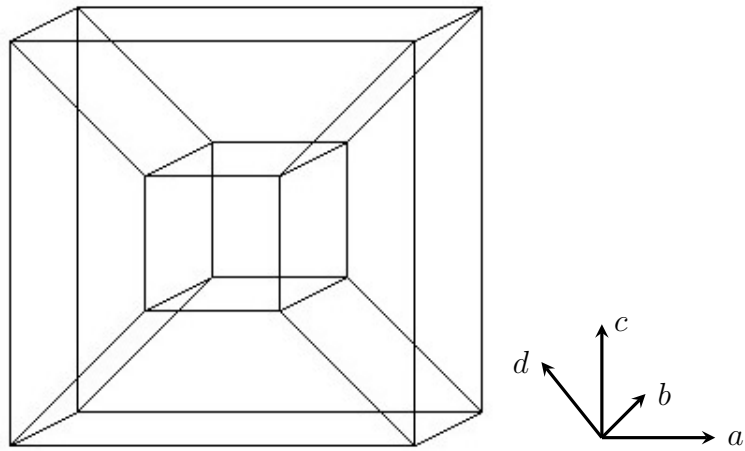

- (a) Draw the minterms on the cube.
- (b) List all the primes (also on the cube).
- (c) List all the essential primes.
- (d) Find a minimum cover using McCluskey's method.

- (e) Show the obtained cover on the cube.

