

Exercise 6: Examination of a road bridge

Determination of strength examination values and structural safety checks

Background (continued from Exercise 5)

The dimensions of the sections and the arrangement of the reinforcing bars are shown on figures 1-4.

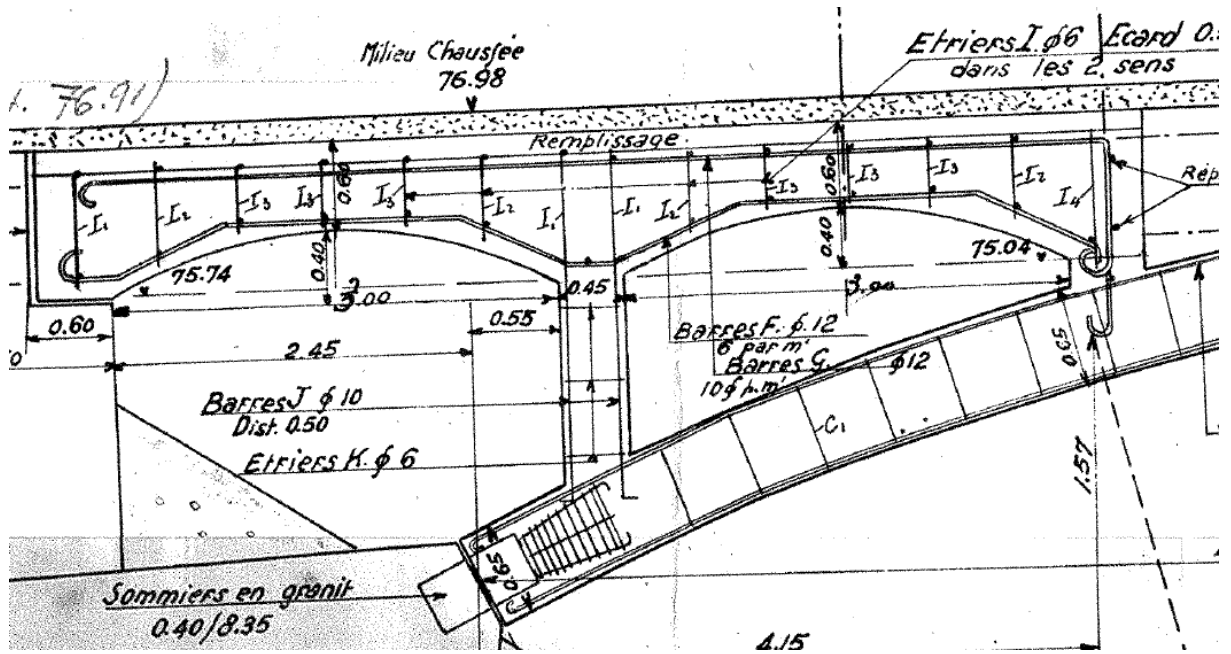

Figure 1: Longitudinal section of the end of the arch.

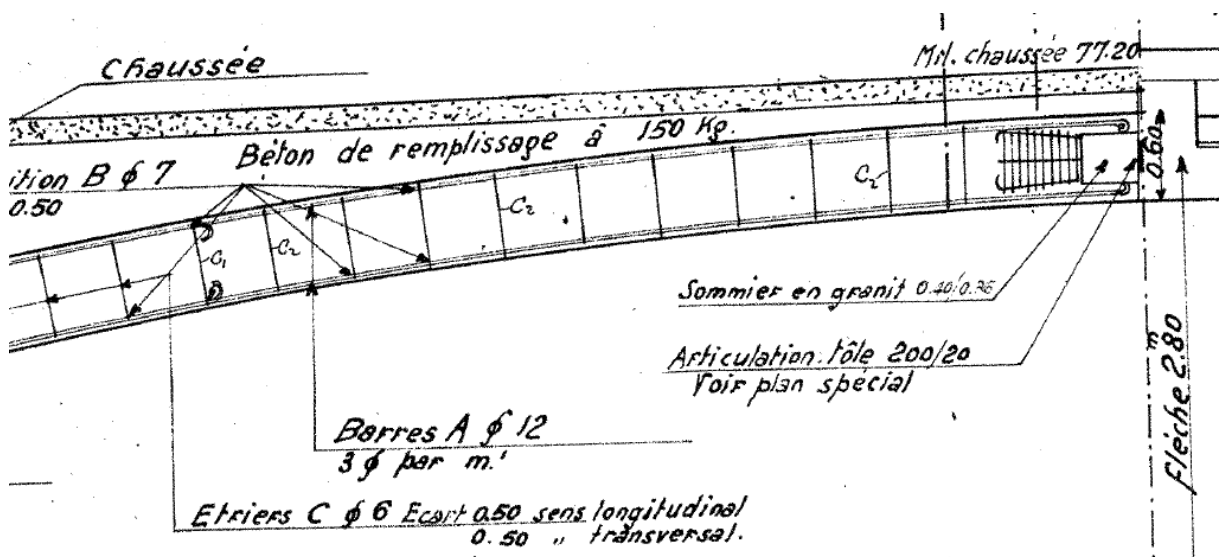

Figure 2: Longitudinal section of the center of the arch.

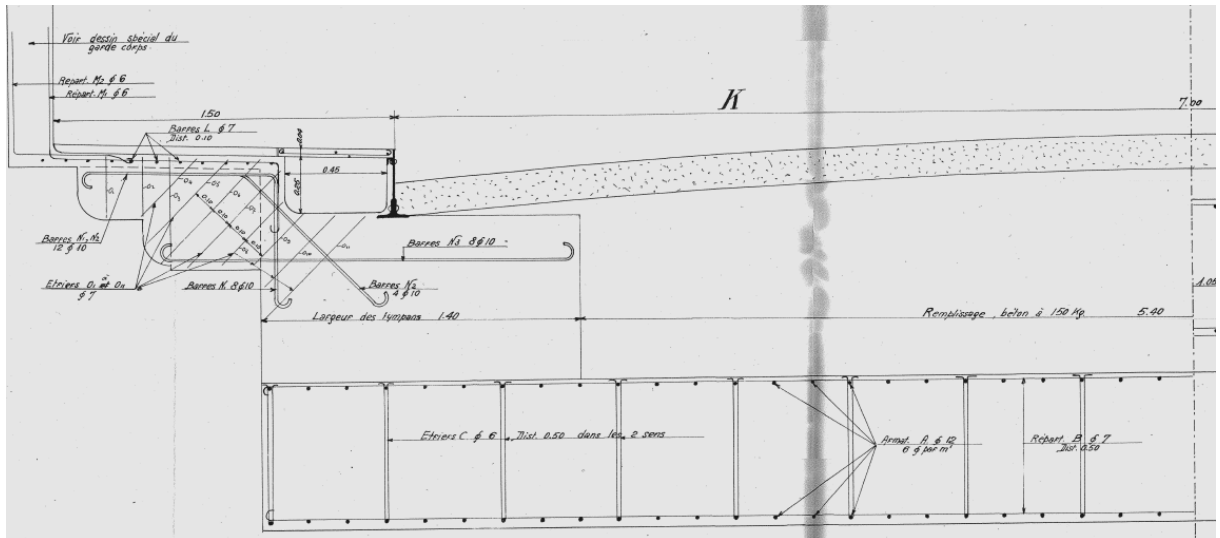

Figure 4: Cross-section of the arch with details of the spandrel.

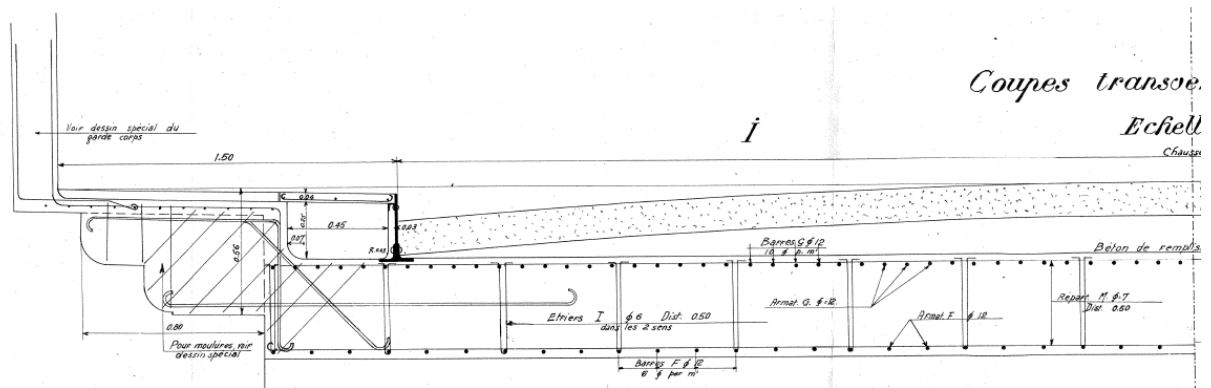

Figure 3: Cross-section of the deck at mid-span of the first arch.

The critical sections to be checked are presented in the following figure:

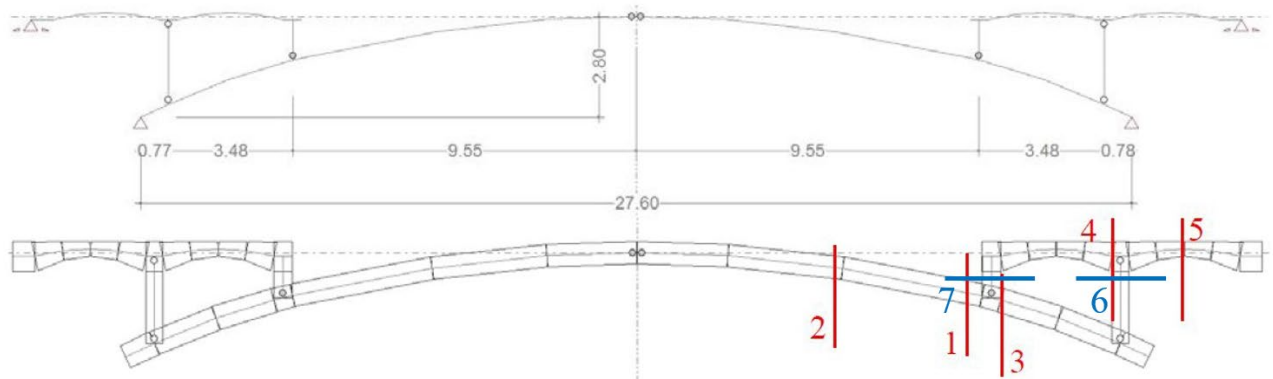

Figure 5: critical sections for examination.

The dimensions and the reinforcements of the sections to be checked are summarized in Table 1.

Table 1: Dimensions of the sections and the reinforcements (cover depth = 30 mm)

Section	Total height [mm]	Position	Diameter [mm]	Spacing [mm]
1	600	sup.	12	167
		inf.	12	167
2	600	sup.	12	333
		inf.	12	333
3	650	sup.	12	167
		inf.	12	167
4	800	sup.	12	100
		inf.	12	167
5	400	sup.	12	100
		inf.	12	167
6	450	sup.	10	500
		inf.	10	500
7	450	sup.	10	500
		inf.	10	500

The characteristic values of the material strengths to determine the sectional strength are as follows:

- Concrete: compressive strength $f_{ck} = 25.0$ MPa;
- Steel: tensile strength (yield point) of reinforcing steel $f_{sk} = 240$ MPa.

Objective

The aim of this exercise is to determine the examination values of the ultimate strength of the load-bearing elements in sections 1 to 5 according to figure 5 and Table 1 for the Guillermaux bridge and to check their structural safety considering the examination values of action effects determined in exercise 5.

Question 1: Examination values

Determine the examination values of the ultimate strength of the arch (normal force, moment) and the deck (moment).

Hint: First, study the effect of the acting normal force on the bending resistance.

Question 2: Structural safety check

Check the structural safety (type 2). Shear forces can be neglected.

Question 3: Discussion and intervention

Discuss the results and recommend possible interventions.

Question 4: Section 6 and 7

Calculate the degree of compliance for the sections 6 and 7 under normal forces loading only (i.e. the consideration is made that the ends of the cross walls are hinged).

Note: this document is a translation of the exercise 3, lecture notes Prof. Eugen Brühwiler “Structures existantes I : Examen et interventions – Bases”, 2022 edition, course CIVIL-436, courtesy of Prof. Brühwiler.

EB/aa-mp-ed – 11.2025