

# Lecture 11

# Safety and Reliability

# in Civil Engineering

CIVIL-239: Engineering a sustainable built environment

Andrew Sonta (and David Ruggiero)

# Housekeeping

- Assignment 5 due December 17 before class
- Next week: Industry Guest Lecture from Benoit Klein from Implenia
  - Short exercise to be completed before the lecture

| <b>Materials, structures, and life-cycle assessment</b>   |        |   |  |              |
|---|--------|---|--|--------------|
| 9   | 5-Nov  | Life-cycle assessment   | Environmental LCA  |              |
| 10  | 12-Nov | <b>Guest lecture:</b> Embodied carbon emissions and materials                           | The phases of infrastructure life cycles   |              |
| <b>Civil engineering and natural systems</b>              |        |   |  |              |
| 11  | 19-Nov | Engineering with natural systems; geotechnical engineering, water resources engineering | Multi-criteria decision-making, resilience, sensitivity analysis, nature-based solutions |              |
| 12  | 26-Nov | <b>Guest lecture:</b> Assigning value to natural systems                                | Sustainability in natural systems; Engineering and sustainability valuation/economics    | Assignment 4 |
| <b>Sustainability in the civil engineering profession</b> |        |   |  |              |
| 13  | 3-Dec  | Safety and reliability in civil engineering   | Load combinations, safety and reliability, safety factors                                |              |
| 14  | 10-Dec | <b>Guest lecture:</b> Sustainable engineering in the industry                           | Practical issues   |              |
| 15  | 17-Dec | Course wrap up<br>How sustainability targets are implemented<br>Class debate            | Sustainability codes and standards   | Assignment 5 |
| -   | TBD    | <b><i>Final written exam</i></b>  |  |              |

# Circular economy in civil engineering (lecture 7/8)

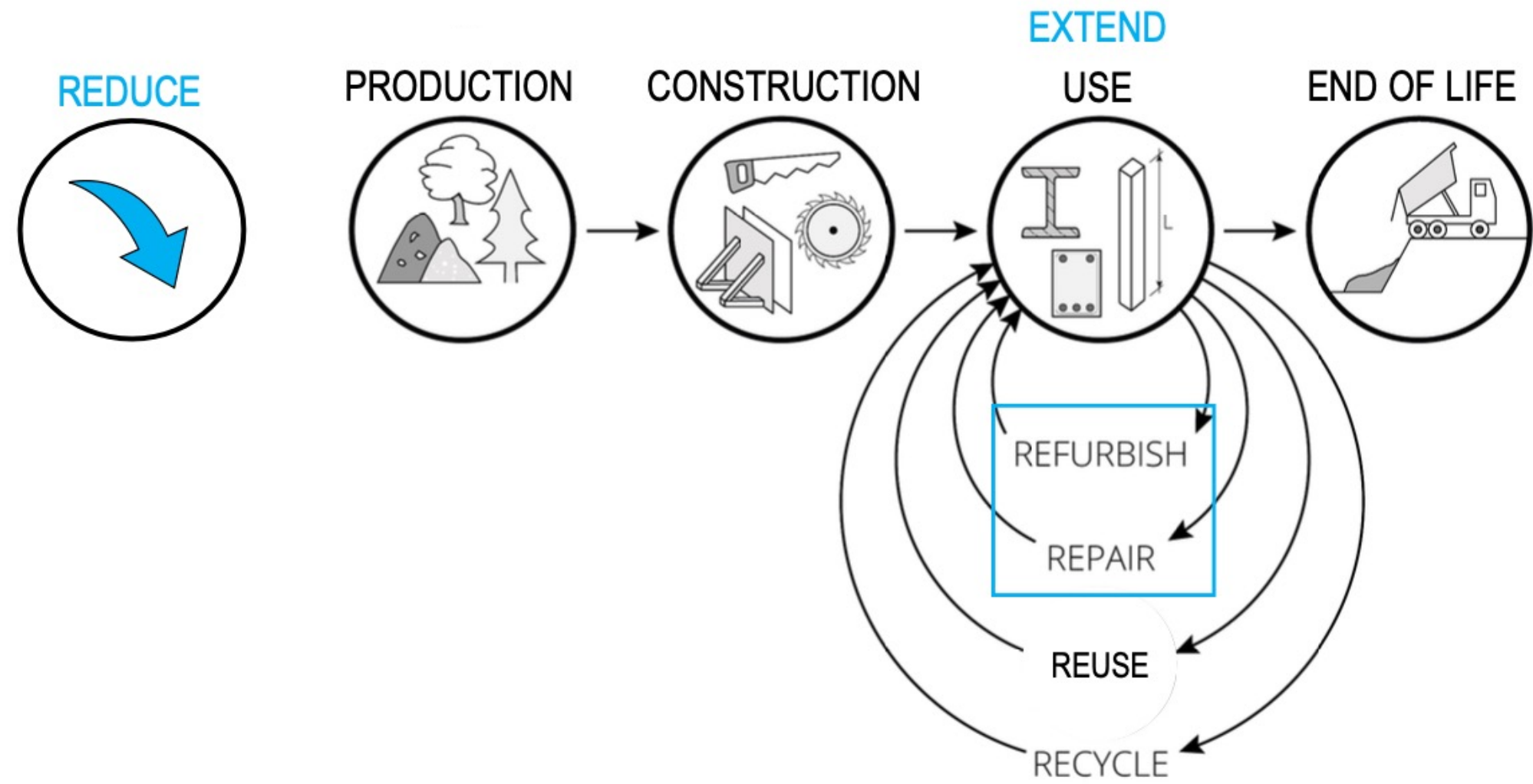

# Resilience (lecture 9)

- Resilience is the capacity of a system to recover and reconstitute critical services with minimal damage to public safety, health, and security
- What is the relationship between resilience and sustainability?

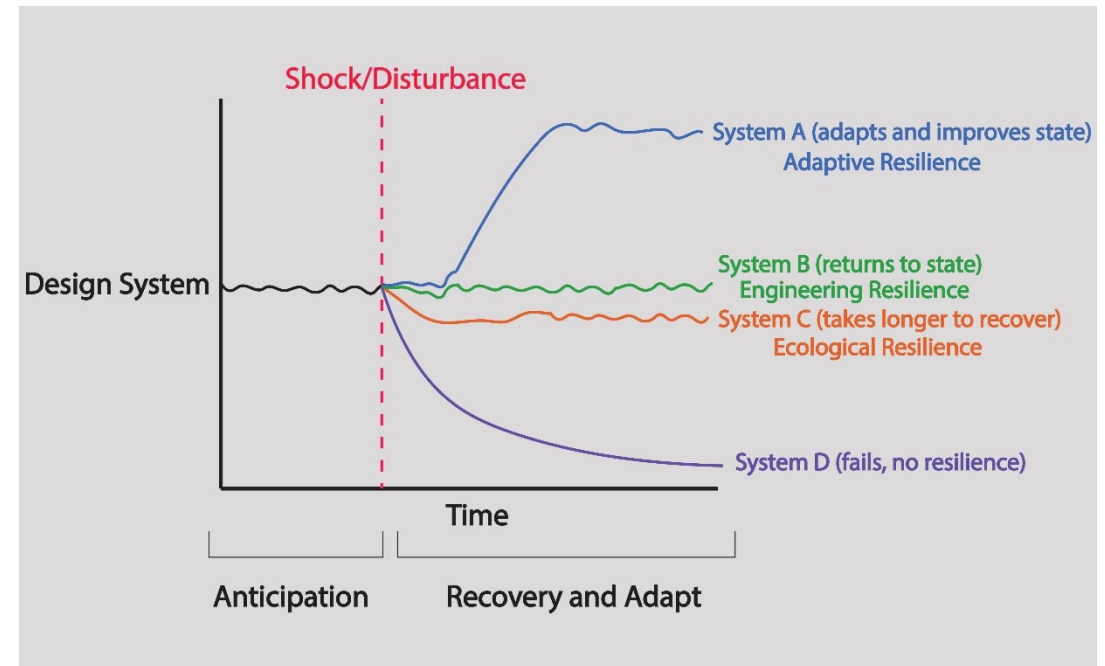
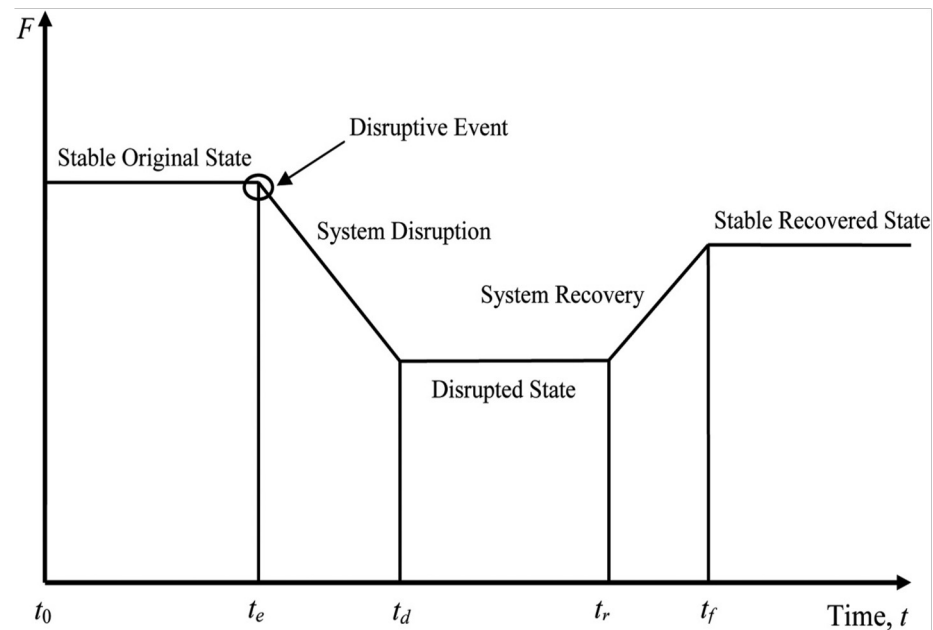

# Example: Christchurch Earthquake

- 6.2 magnitude earthquake near Christchurch, New Zealand
- 185 fatalities
- Following the earthquake, over 60% of concrete buildings in central business district with 3+ stories were demolished
- “... a significant number of buildings with relatively low damage were demolished”





# SAFETY AND RELIABILITY IN CIVIL ENGINEERING



BBC

# Agenda

Introduction

- Risk in the built environment

Risk

- What is risk?

Design philosophy

- Probabilistic background

Structural verification

- Code format

Actions

- Different types



# 1. INTRODUCTION

# Preamble



TABLE 1 *Average annual risk of death as a consequence of an activity*

| Activity associated with death          | Risk of death per person-year |
|---|-------------------------------|
| <b>Voluntary</b>                        |                               |
| Motorcycling                            | $2000.0 \times 10^{-5}$       |
| Smoking (20 cigarettes per day)         | $500.0 \times 10^{-5}$        |
| Car racing                              | $120.0 \times 10^{-5}$        |
| Scuba diving                            | $60.0 \times 10^{-5}$         |
| Surgical anaesthesia                    | $50.0 \times 10^{-5}$         |
| Car driving                             | $17.0 \times 10^{-5}$         |
| Pregnancy                               | $9.8 \times 10^{-5}$          |
| Drinking (one bottle of wine per day)   | $7.5 \times 10^{-5}$          |
| Rock climbing                           | $4.0 \times 10^{-5}$          |
| <b>Involuntary</b>                      |                               |
| Quarry accidents                        | $18.0 \times 10^{-5}$         |
| Rail travel accidents                   | $6.0 \times 10^{-5}$          |
| Work in the service industry            | $0.4 \times 10^{-5}$          |
| Floods (USA)                            | $0.22 \times 10^{-5}$         |
| Tornadoes (Mid west USA)                | $0.22 \times 10^{-5}$         |
| Earthquake (California)                 | $0.17 \times 10^{-5}$         |
| Storms (USA)                            | $0.08 \times 10^{-5}$         |
| Lightning                               | $0.01 \times 10^{-5}$         |
| Aircraft accidents                      | $0.01 \times 10^{-5}$         |
| Release from nuclear power station      | $0.01 \times 10^{-5}$         |
| Explosion of pressure vessel            | $0.005 \times 10^{-5}$        |
| Transport of petrol and chemicals (USA) | $0.005 \times 10^{-5}$        |
| Leukemia                                | $8.0 \times 10^{-5}$          |
| Influenza                               | $20.0 \times 10^{-5}$         |
| Meteorite                               | $0.000\,006 \times 10^{-5}$   |
| Cosmic rays from explosion of supernova | Less than $0.000\,000\,01$    |

“Acceptable” risk of death in structures

$0.1 \times 10^{-5}$  to  $0.3 \times 10^{-5}$

International Organization for Standardization (ISO). *ISO 2394: General Principles on Reliability for Structures*. Geneva: ISO, 2015.

Nivolianitou, Zoe. (2002). Risk analysis and risk management: a European insight. Law, Probability and Risk. 1. 10.1093/lpr/1.2.161.

# Structures

## Buildings



## Industry



## Infrastructure



## Environment



# Structures

- Fulfill some purpose
  - Shelter, connection, production, etc.
- “Structural failure”
  - Failure to serve this purpose
  - Can be catastrophic, but not necessarily



# Codes, standards, norms

- Switzerland
  - SIA (Swiss Society of Engineers and Architects)
  - SIA 260 – Basis of Structural Design
  - SIA 261 – Actions on Structures
- Europe
  - Eurocodes
  - EN 1990 – EN 1999

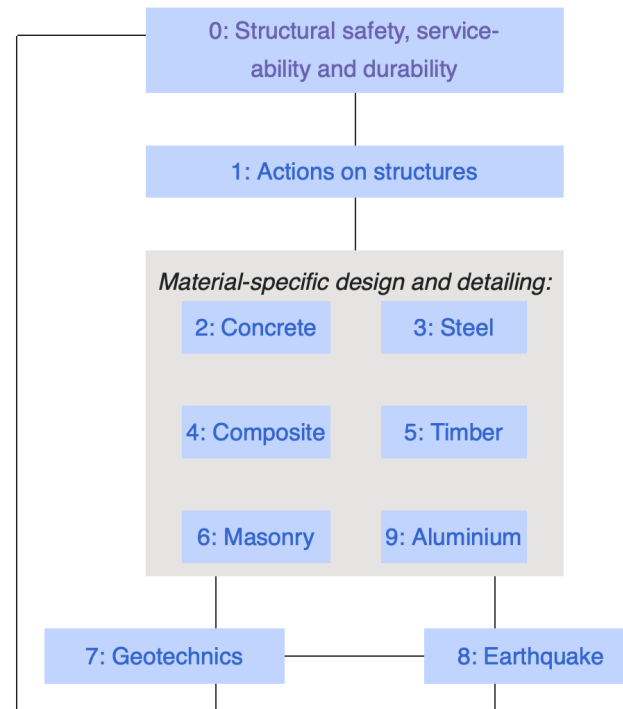

## 2. RISKS

# Risk

$$Risk = Hazard \times Exposure \times Vulnerability$$

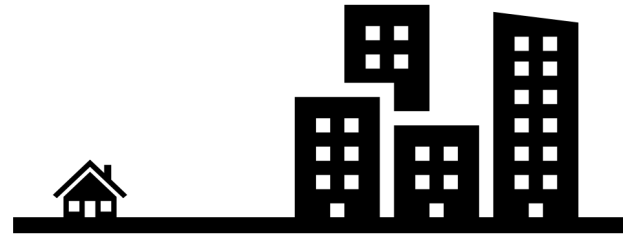
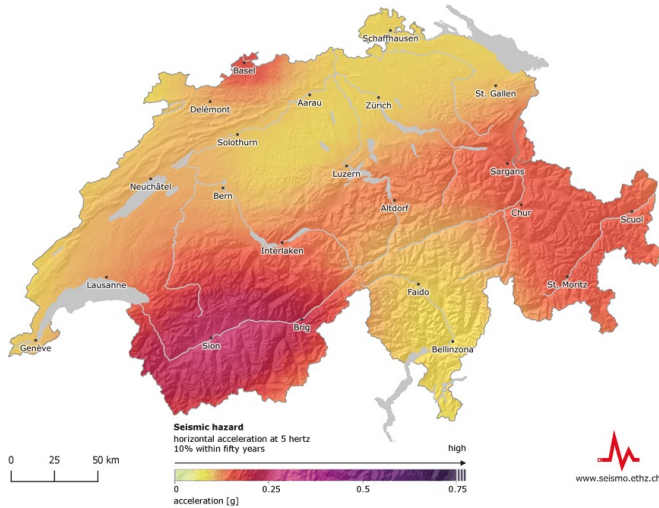

**Exposure:** the inventory of elements in an area in which hazard events may occur

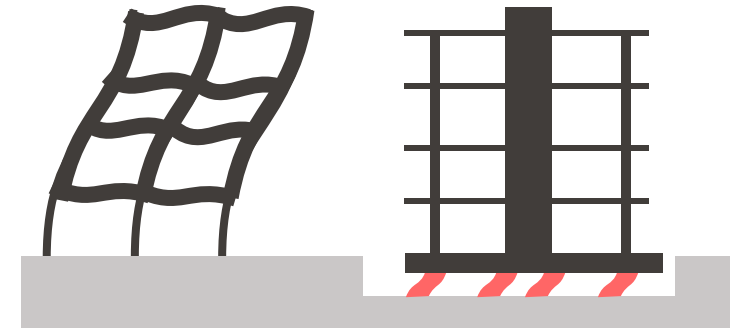

**Vulnerability:** the propensity of exposed elements such as human beings, their livelihoods, and assets to suffer adverse effects when impacted by hazard events

Source: IPCC

# Environmental hazards

Wind



Snow



Earthquake



Flood



etc.

# Human hazards

Design error



Overload



Fire



etc.

# Durability hazards



etc.

# Risk scenarios

- Multiple hazards can occur at the same time

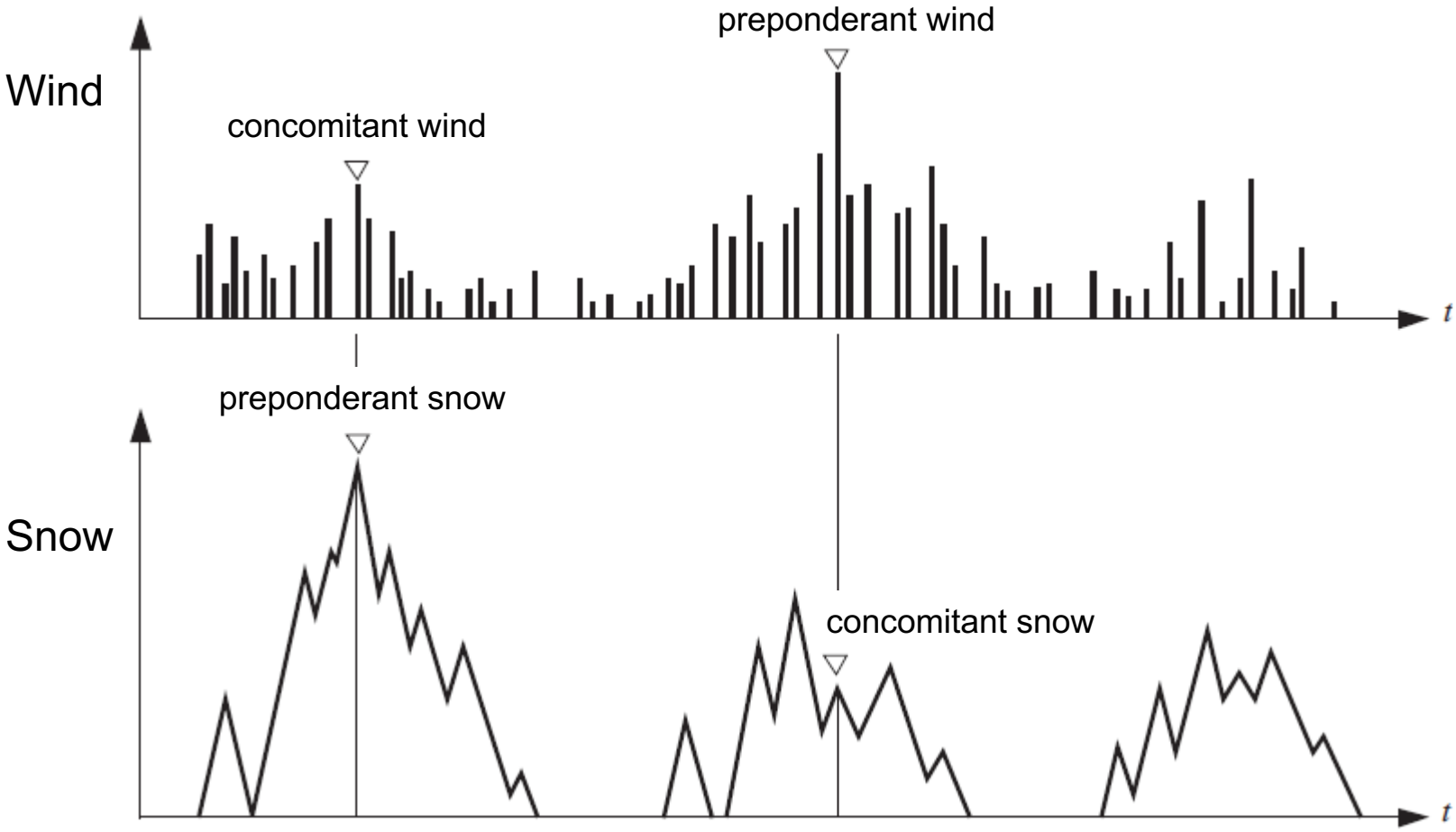

# Managing hazards

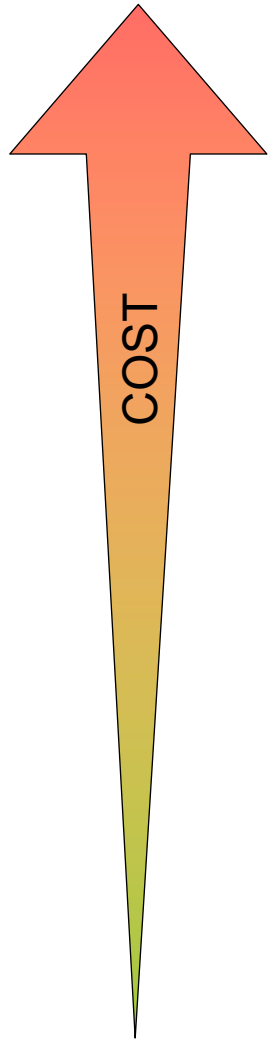

- Eliminate the hazard by addressing its source
- Avoid the hazard by circumventing dangerous situations
- Overcome the hazard by planning for monitoring, controls, or alarm systems
- Control the hazard by providing sufficient reserves
- Consciously accept the hazard as unavoidable or as a sufficiently small risk to be considered within acceptable limits

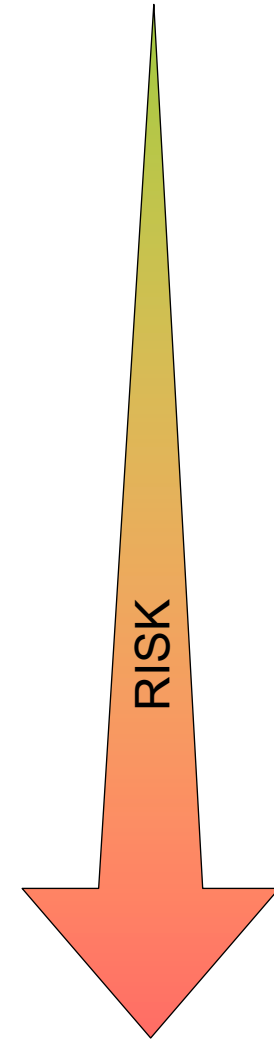

## 3. DESIGN PHILOSOPHY

# Main idea

*Resistance*  $\geq$  *Action Effects*

$$R \geq E$$

Example:

$$M_R \geq M_E$$

Moment capacity

Moment demand

# Action effects

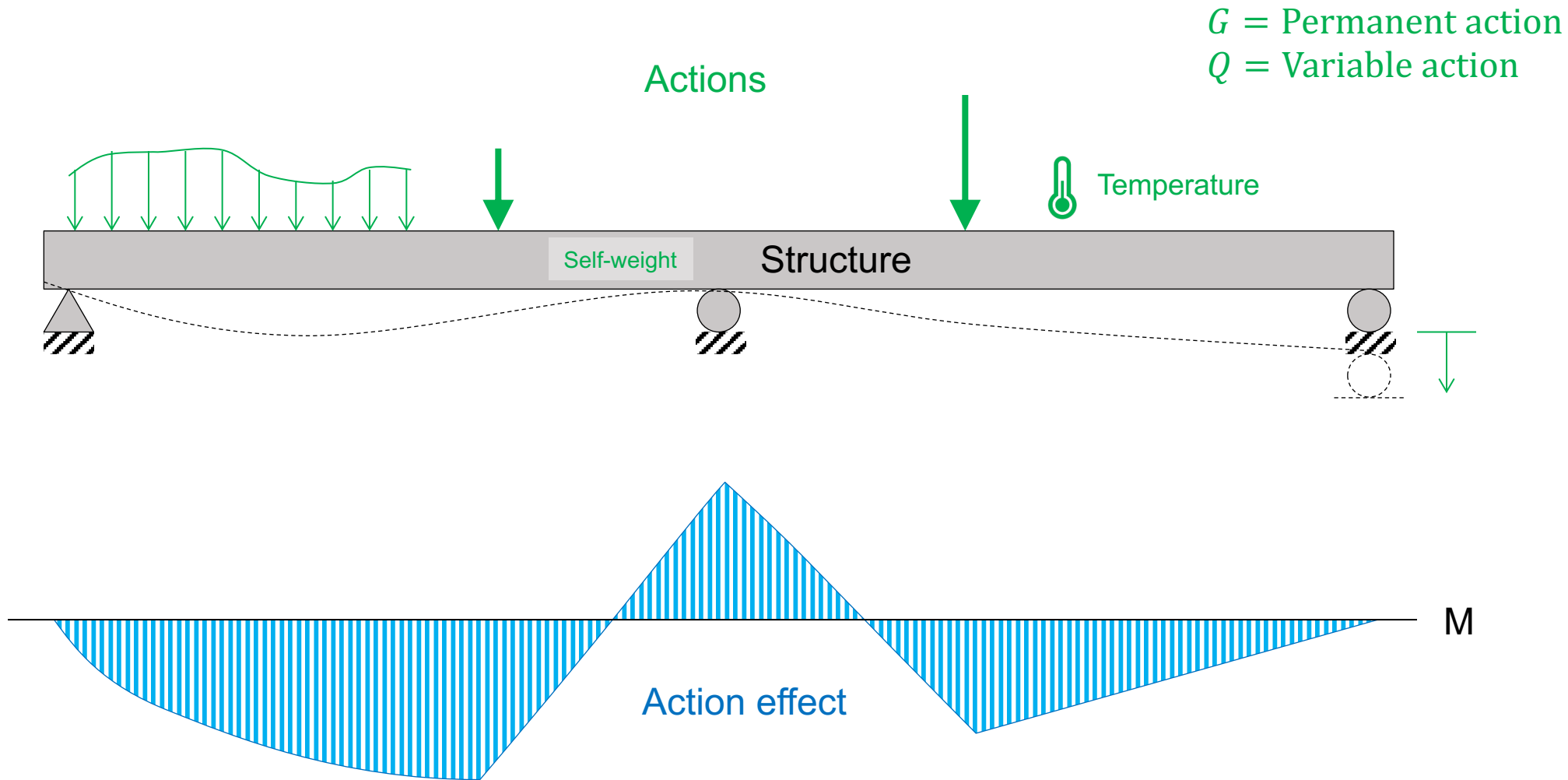

# Probabilistic approach

- Want:

$$R \geq E$$

- Issue: capacity ( $R$ ) and demand ( $E$ ) are actually random variables
- Probabilistic statement:

$$P(R < E) < \text{acceptable limit}$$

# Sources of variability

## Variability of resistance

- Imprecise modelling of local resistance
- Material properties influencing local resistance
- Geometric properties influencing local resistance

## Variability of action effect

### Uncertainty of actions themselves

- Environmental uncertainty
- Imprecise modelling of actions
- Geometric properties influencing actions

### Uncertainty of action effects given actions

- Mechanical behaviour
- Modelling choices
- Material properties influencing action effects
- Geometric properties influencing action effects

# Probabilistic approach

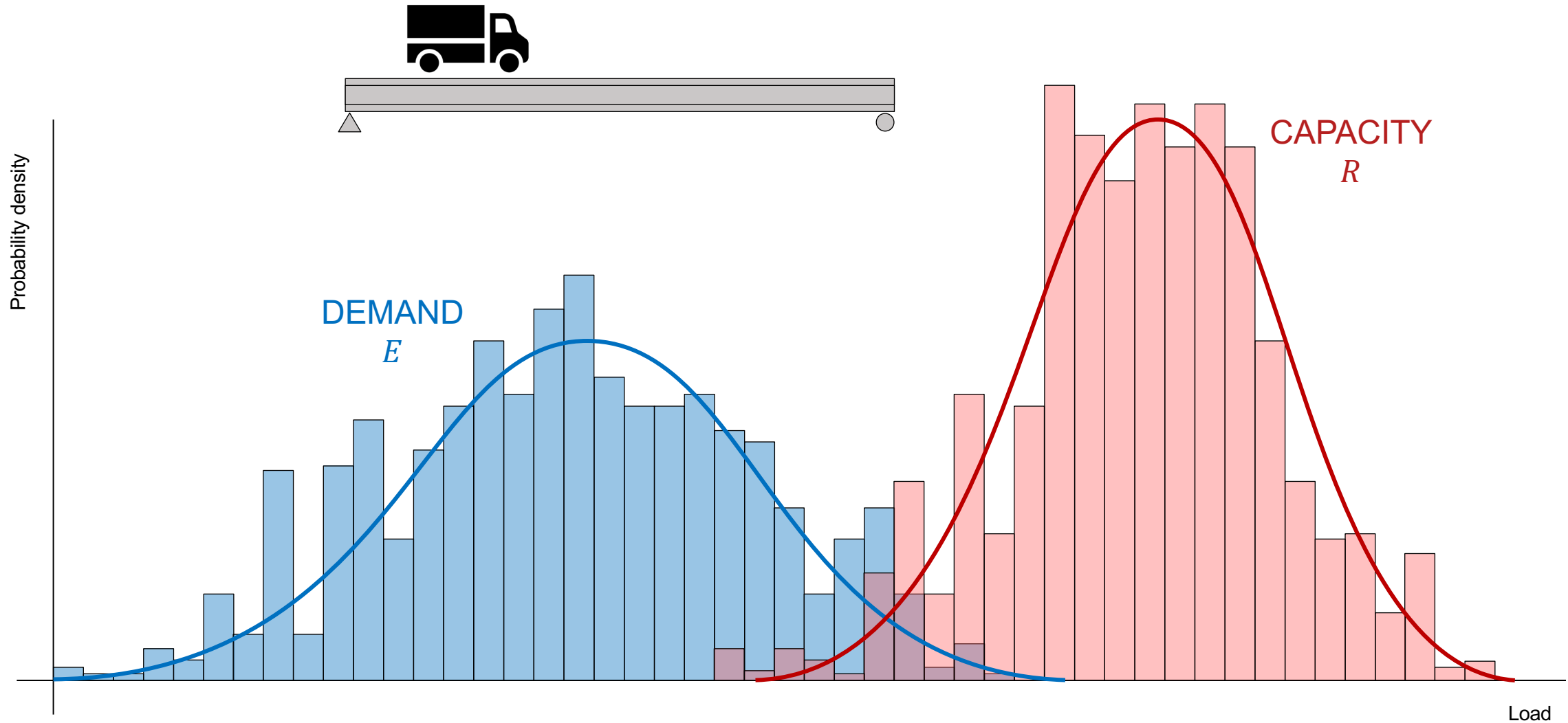

# Reliability index $\beta$

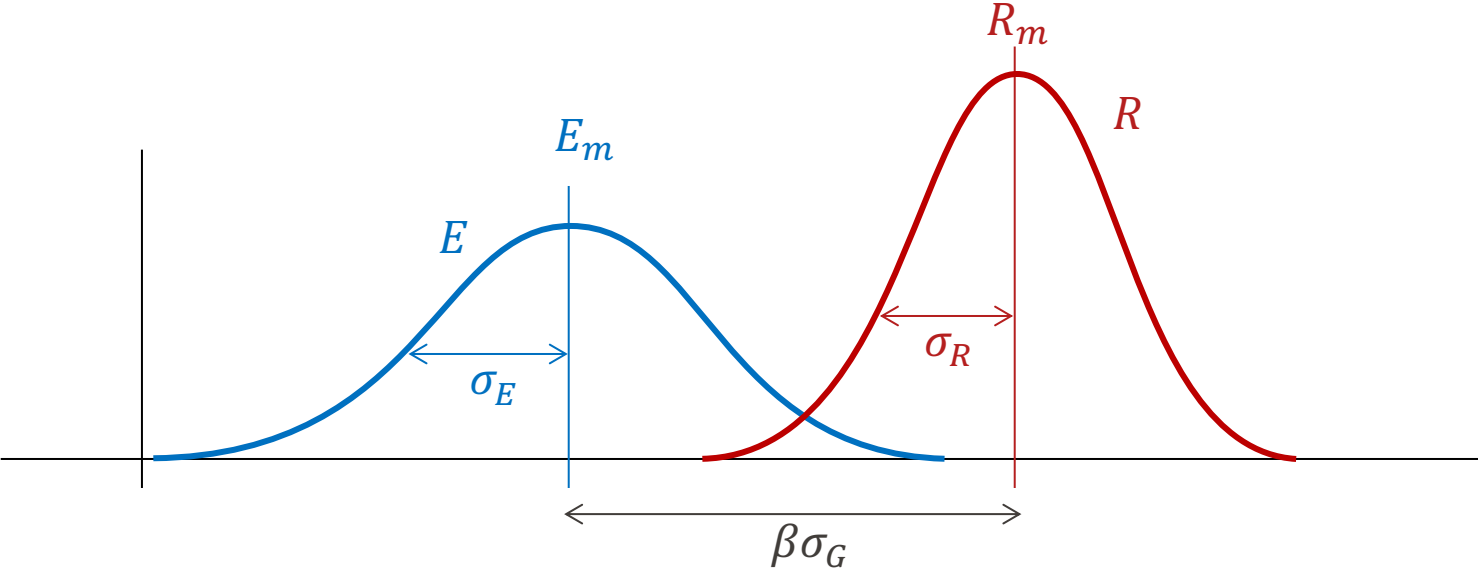

- Define limit state function:  $G = R - E$

Probability of failure =  $p_f = P(G < 0)$

$\beta$  is the number of standard deviations separating the mean value  $G_m$  from the origin

Assume  $G$  is normal:  
 $p_f = \Phi(-\beta)$

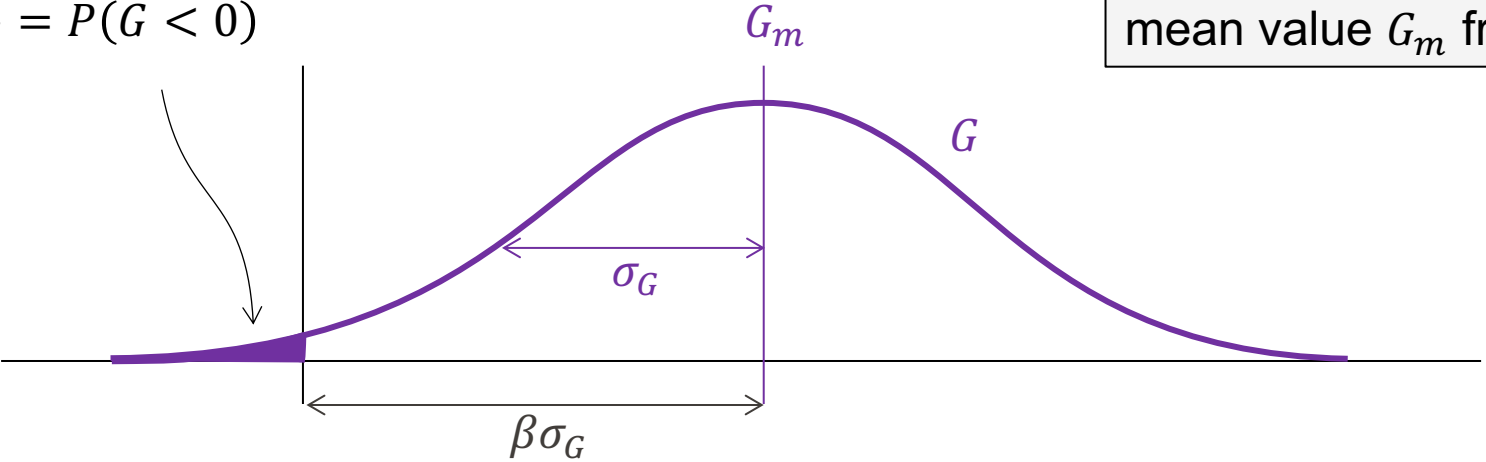

# Reliability index $\beta$

- By properties of Normal random variables:

$$G = R - E$$

$$G_m = R_m - E_m$$

$$\sigma_G^2 = \sigma_R^2 + \sigma_E^2$$

$$\therefore \beta = \frac{R_m - E_m}{\sqrt{\sigma_R^2 + \sigma_E^2}}$$

# Reliability index $\beta$

Example: Recommended target reliability indices according to *fib* Model Code 2010  
(1 year reference period):

| Limit state                   | $\beta$ | $p_f$      | 1 in ...  |
|-------------------------------|---------|------------|-----------|
| Serviceability                | 3.0     | 0.135%     | 741       |
| Ultimate – Low consequence    | 4.1     | 0.00207%   | 48 409    |
| Ultimate – Medium consequence | 4.7     | 0.000130%  | 768 753   |
| Ultimate – High consequence   | 5.1     | 0.0000170% | 5 888 354 |

# Practicality

- Full probabilistic method is hard to use in practice
- We rarely have enough information about the variability to quantify both resistance and action effect accurately
- Simplified methods used for “everyday” design

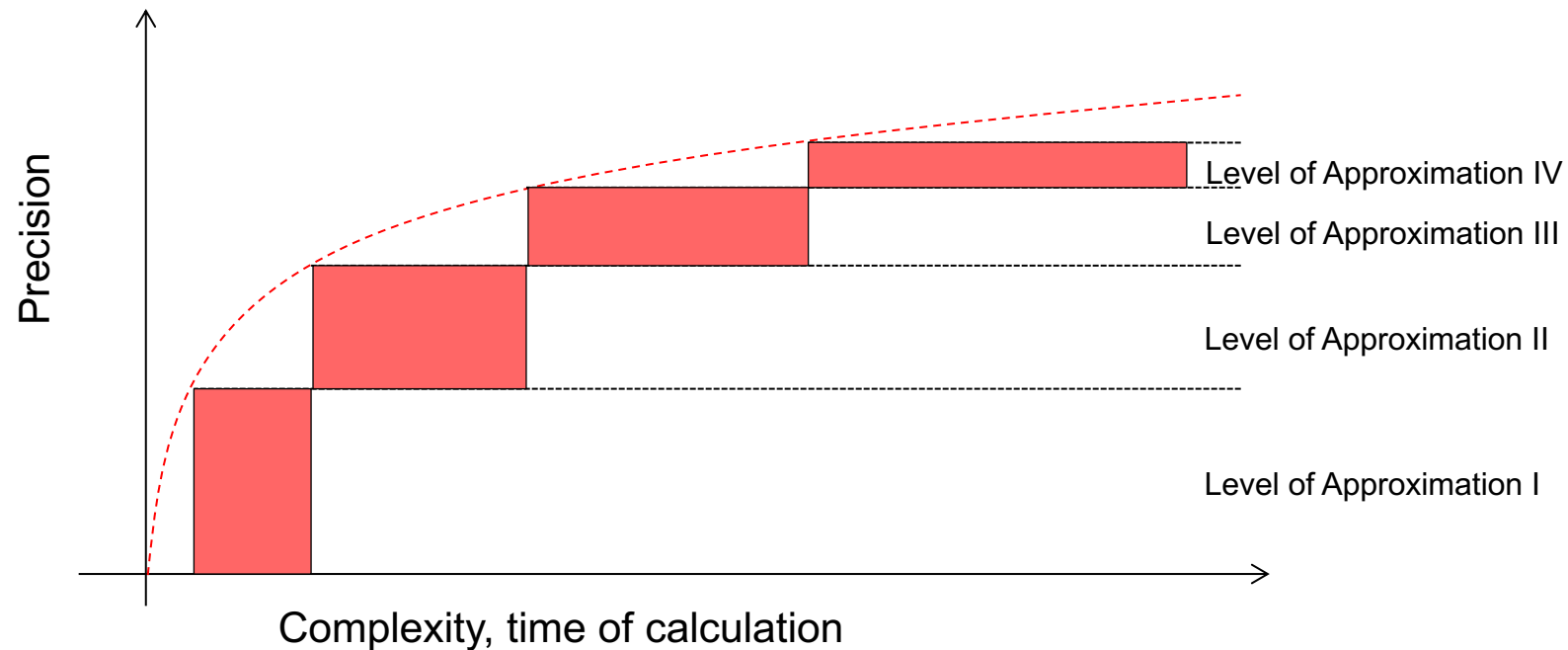

## 4. STRUCTURAL VERIFICATION

# Limit states

- Ultimate limit states (ULS) – Life-safety
  - Stability
  - Resistance
  - Soil/terrain
  - Fatigue
- Serviceability limit states (SLS) – Utilization
  - Deflection, cracking, comfort, etc.

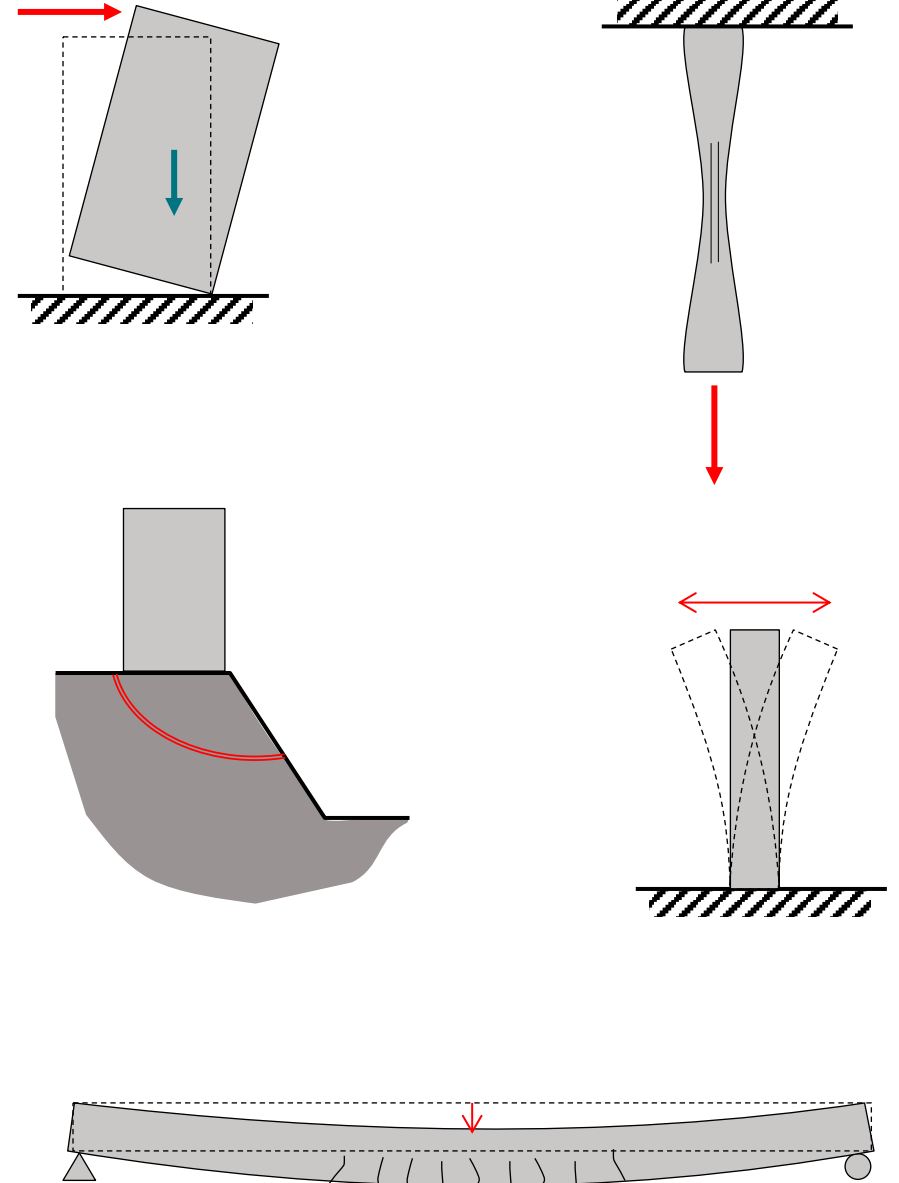

# ULS Resistance – Deterministic method

- Check **limit states** using **design values**
- Does not explicitly take into account statistical distributions – single values

Design resistance

Design action effects

$$R_d \geq E_d$$

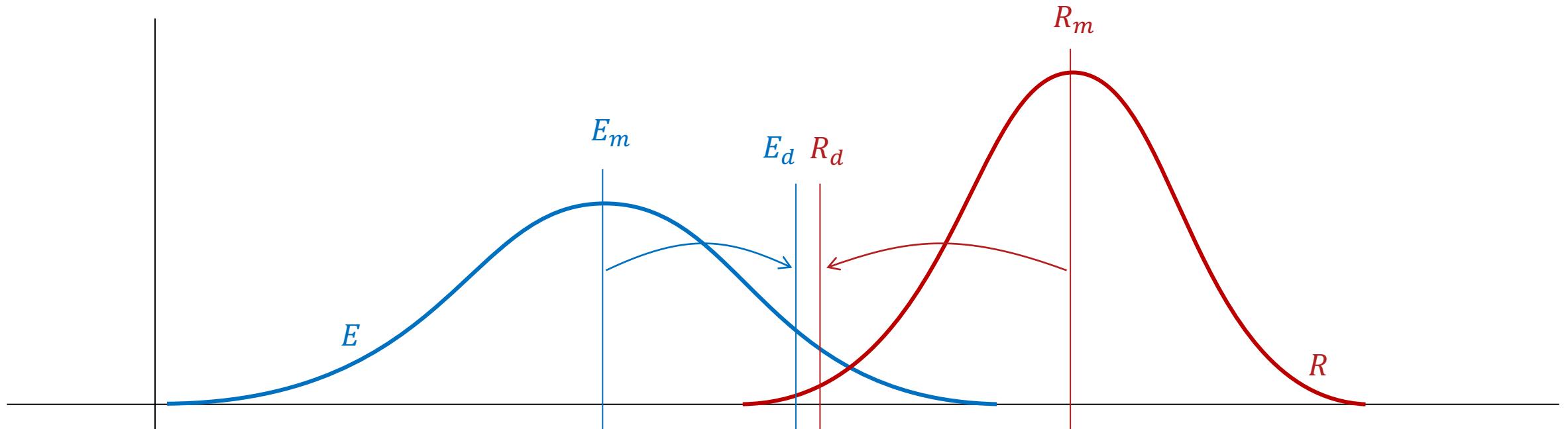

# Design values

$$E_d = E\{F_d, \dots\} \quad \text{where} \quad F_d = \gamma_F F_k$$

$F$  = action

$$R_d = R\{X_d, \dots\} \quad \text{where} \quad X_d = \frac{\eta X_k}{\gamma_X}$$

$X$  = material property  
 $\eta$  = modification factor

$\gamma$  = partial safety factor  
 $d$  = "Design"  
 $k$  = "Characteristic"

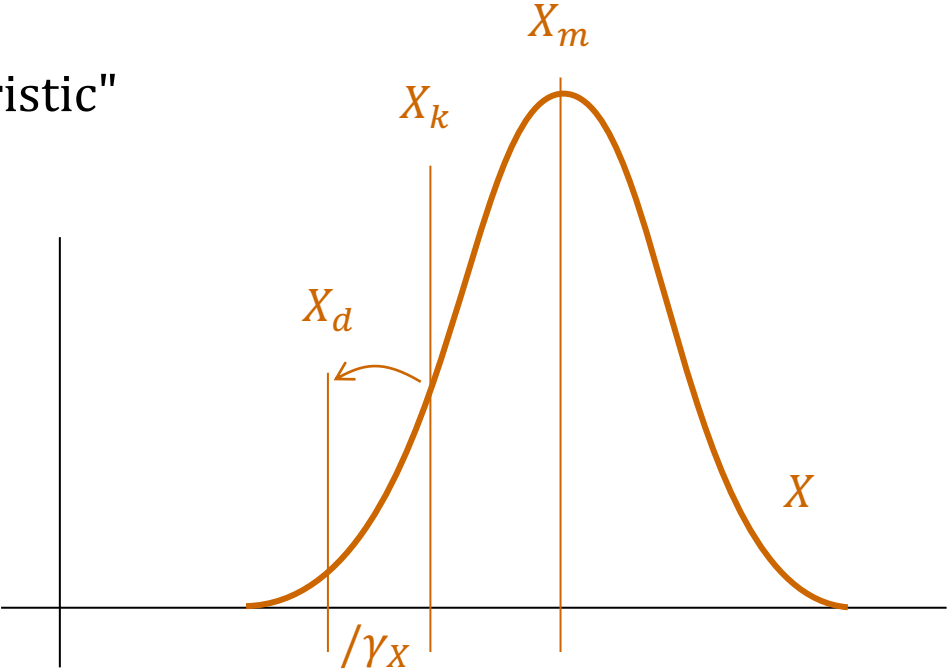
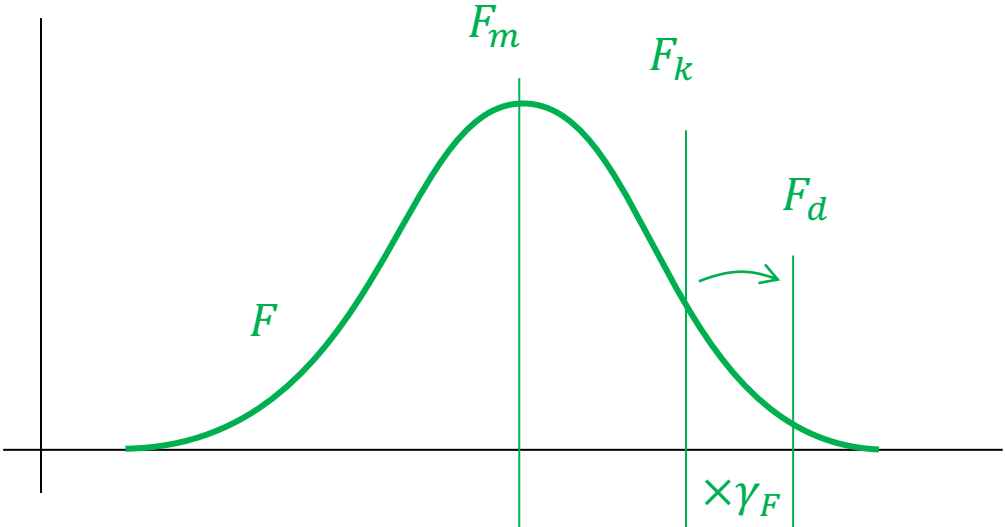

*Note: this is a bit of a simplification; for certain types of verifications the safety factors are included differently, there are other parameters, etc.*

# Characteristic values

- Often represent statistical values

Examples:

Permanent loads – Given fractile value

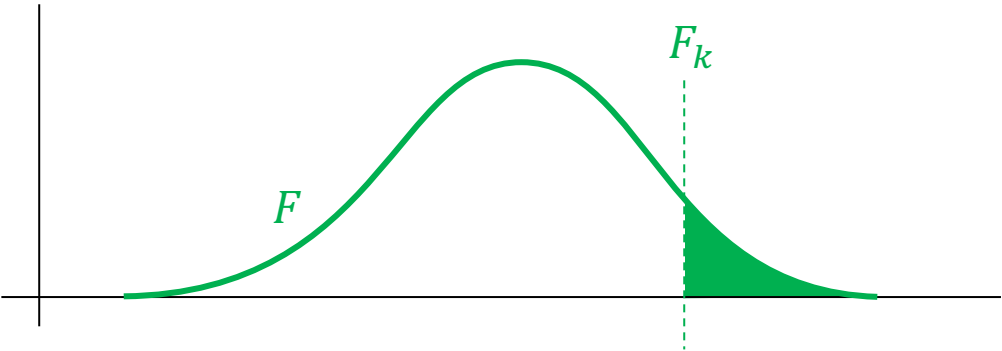

Materials – Given fractile value (often 5%)

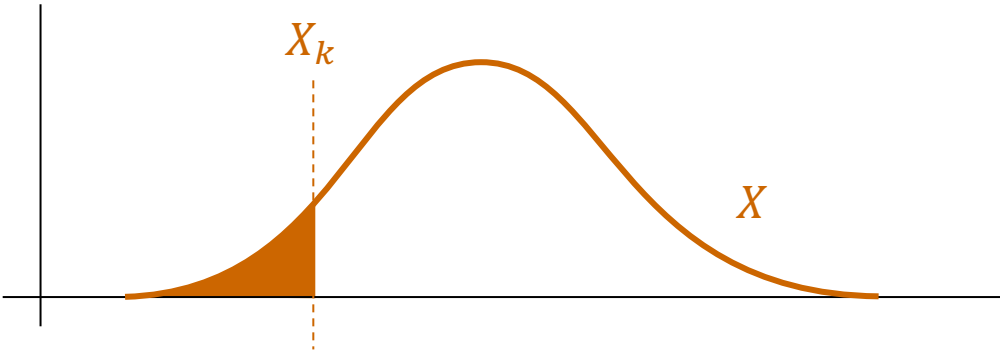

Variable loads – Given probability of exceedance (over time span)

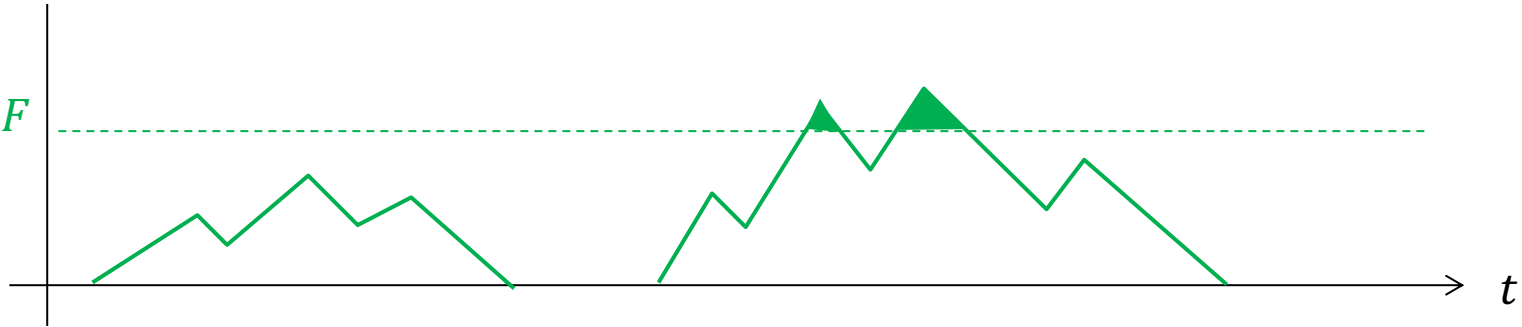

# Example

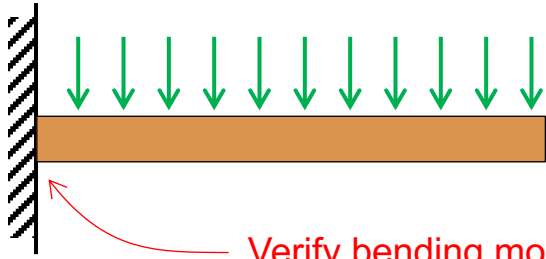

Verify bending moment at support

Action: distributed load of  $F_k = 2 \text{ kN/m}$

Material: wood beam with strength of  $X_k = 15 \text{ MPa}$

Partial safety factors:

$$\gamma_F = 1.5$$

$$\gamma_X = 1.7 \quad \eta = 1.0$$

Geometry:

Length  $L = 3 \text{ m}$

Section modulus  $W = 5\,000\,000 \text{ mm}^3$

Design action effect:

$$M_{Ed} = \frac{F_d L^2}{2} = \frac{\gamma_F F_k \cdot L^2}{2} = 13.5 \text{ kNm}$$

Design resistance:

$$M_{Rd} = W X_d = W \cdot \frac{X_k}{\gamma_X} = 17.6 \text{ kNm}$$

$M_{Rd} > M_{Ed}$  so resistance is OK!

# Partial safety factors vs. single safety factor

- Why not? Historically a single safety factor was used (“Allowable Stress Design”)

Counterexample:

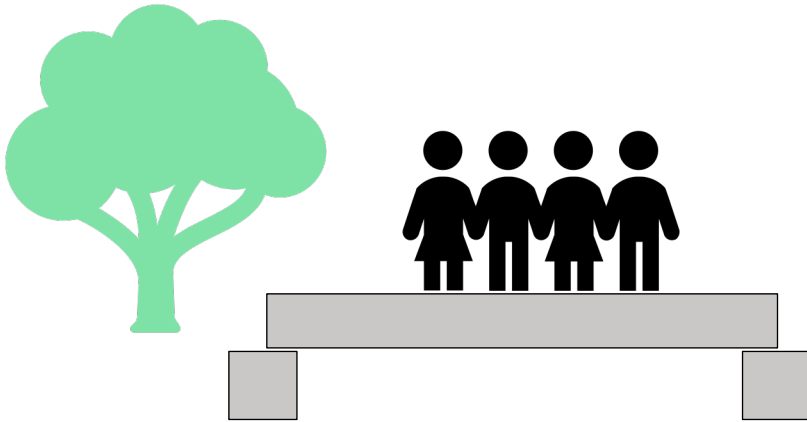

Short bridge

- Action dominated by live load (high variability)
- Safety factor tends to be unconservative

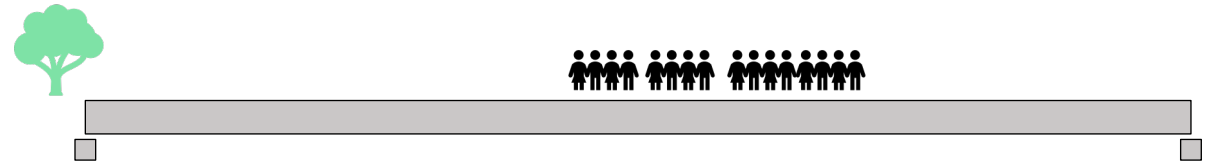

Long bridge

- Action dominated by dead load (low variability)
- Safety factor tends to be overconservative

# Partial safety factors

- Type 2 = resistance check
- Dead load is considered with upper and lower bounds to find worst case
- Live load may need to be patterned to find worst case (discussed later)

SIA260 Table 1

| Actions  | $\gamma_F$         | État-limite        |                       |        |
|--|--------------------|--------------------|-----------------------|--------|
|  |                    | Type 1             | Type 2                | Type 3 |
| Actions permanentes<br>– avec effet défavorable<br>– avec effet favorable  | $\gamma_{G,sup}$   | 1,10 <sup>1)</sup> | 1,35 <sup>1)</sup>    | 1,00   |
|  | $\gamma_{G,inf}$   | 0,90 <sup>1)</sup> | 0,80 <sup>1)</sup>    | 1,00   |
| Actions variables<br>– en général<br>– charges dues au trafic routier<br>– charges dues au trafic ferroviaire<br>– modèles de charge 1, 2, 4 à 7<br>– modèle de charge 3   | $\gamma_Q$         | 1,50               | 1,50                  | 1,30   |
|  | $\gamma_Q$         | 1,50               | 1,50                  | 1,30   |
|  | $\gamma_Q$         | 1,45               | 1,45                  | 1,25   |
|  | $\gamma_Q$         | 1,45               | 1,20                  | 1,25   |
| Actions du terrain de fondation<br>Charges de terre<br>– avec effet défavorable<br>– avec effet favorable  | $\gamma_{G,sup}$   | 1,10               | 1,35 <sup>2) 3)</sup> | 1,00   |
|  | $\gamma_{G,inf}$   | 0,90               | 0,80                  | 1,00   |
| Poussée des terres<br>– avec effet défavorable<br>– avec effet favorable <sup>4)</sup>   | $\gamma_{G,Q,sup}$ | 1,35               | 1,35                  | 1,00   |
|  | $\gamma_{G,Q,inf}$ | 0,80               | 0,70                  | 1,00   |
| Pression hydraulique<br>– avec effet défavorable<br>– avec effet favorable   | $\gamma_{G,Q,sup}$ | 1,05               | 1,20 <sup>3)</sup>    | 1,00   |
|  | $\gamma_{G,Q,inf}$ | 0,95               | 0,90                  | 1,00   |
| <sup>1)</sup> G est multiplié par $\gamma_{G,sup}$ ou par $\gamma_{G,inf}$ , selon que l'effet d'ensemble de l'action est défavorable ou favorable.<br><sup>2)</sup> Pour des hauteurs de remblai de 2 à 6 m, $\gamma_{G,sup}$ peut être réduit linéairement de 1,35 à 1,20.<br><sup>3)</sup> Lors de l'application de la méthode observationnelle, des valeurs réduites sont admises dans certains cas, selon la norme SIA 267.<br><sup>4)</sup> Pour la butée des terres exerçant une action favorable, on a $F_d = R_d$ , selon la norme SIA 267. |                    |                    |                       |        |

# SLS – Serviceability

- Similar to ULS, we compare load effects (e.g. deflection) with a limit value

$$E_{ser} \leq C_{ser}$$

- Different limit states may be considered depending on specific requirements (deflection, crack width, vibration, etc.)



# SLS limits

- Different serviceability limits need to be checked; e.g. deflection limits below

**SIA260 Annex A Table 3 (buildings)**

| État-limite  | Conséquences des effets des actions |  |                              |
|--|-------------------------------------|--|------------------------------|
|  | irréversibles                       | réversibles  | réversibles                  |
|  | Cas de charge                       |  |                              |
|  | rare (20)                           | fréquent (21)  | quasi permanent (22)         |
| Aptitude au fonctionnement<br>– Éléments incorporés à caractère fragile<br>– Éléments incorporés à caractère ductile<br>– Utilisation et exploitation  | $w \leq l/500$ <sup>1) 2)</sup>     | $w \leq l/350$ <sup>1)</sup><br>$w \leq l/350$ <sup>3)</sup> |                              |
| Confort  |                                     | $w \leq l/350$ <sup>3)</sup>                                 |                              |
| Aspect   |                                     |  | $w \leq l/300$ <sup>4)</sup> |
| <sup>1)</sup> Flèche due aux actions, en particulier aux actions à long terme, après le montage de tous les éléments de construction secondaires et la mise en place de l'équipement technique.<br><sup>2)</sup> Si des éléments incorporés réagissent de manière particulièrement sensible aux déformations de la structure porteuse, il faut avant tout prévoir des mesures constructives contre les dommages, en plus ou à la place des mesures découlant de la procédure de dimensionnement.<br><sup>3)</sup> Flèche due uniquement aux actions variables.<br><sup>4)</sup> Flèche, après déduction d'une éventuelle contreflèche. Les éventuels effets à long terme doivent être pris en considération. |                                     |  |                              |
| Les flèches seront déterminées selon les indications des normes SIA 262 à 266.<br><br>Des valeurs limites différentes pour les flèches peuvent être convenues en accord avec les exigences d'utilisation. Elles seront consignées dans la base du projet. Des exigences réduites sont envisageables spécialement pour les éléments de construction secondaires.  |                                     |  |                              |

**SIA260 Annex B Table 7 (road bridges)**

| État-limite   | Conséquences des effets des actions |  |                                 |
|---|-------------------------------------|--|---------------------------------|
|   | irréversibles                       | réversibles                                      | réversibles                     |
|   | Cas de charge                       |  |                                 |
|   | rare (20)                           | fréquent (21)                                    | quasi permanent (22)            |
| Aptitude au fonctionnement<br>– Déplacement vertical relatif au joint de transition de la chaussée  |                                     | $\delta_v \leq 5 \text{ mm}$ <sup>1) 2) 3)</sup> |                                 |
| Confort   |                                     | $w \leq l/500$ <sup>4)</sup>                     |                                 |
| Aspect  |                                     |  | $w \leq l/700$ <sup>1) 2)</sup> |
| <sup>1)</sup> Flèche après déduction d'une éventuelle contreflèche. Les éventuels effets à long terme dus au retrait, à la relaxation ou au fluage doivent être pris en considération.<br><sup>2)</sup> Flèche due aux actions, en particulier aux actions à long terme, après le montage de l'équipement technique principal<br><sup>3)</sup> Si des éléments incorporés réagissent de manière particulièrement sensible aux déformations de la structure porteuse, il faut avant tout prévoir la prise de mesures techniques contre les dommages, en plus ou à la place des mesures découlant de la procédure de dimensionnement. Les directives émises par les fabricants et les soumissionnaires des produits de construction doivent être respectées.<br><sup>4)</sup> Flèche due à la valeur fréquente du modèle de charge 1. |                                     |  |                                 |
| Les flèches seront déterminées selon les indications des normes SIA 262 à 266.<br><br>Des valeurs limites différentes pour les flèches peuvent être convenues en accord avec les exigences d'utilisation. Elles seront consignées dans la base du projet. Des exigences réduites sont envisageables spécialement pour les éléments de construction secondaires.   |                                     |  |                                 |

# Load combinations

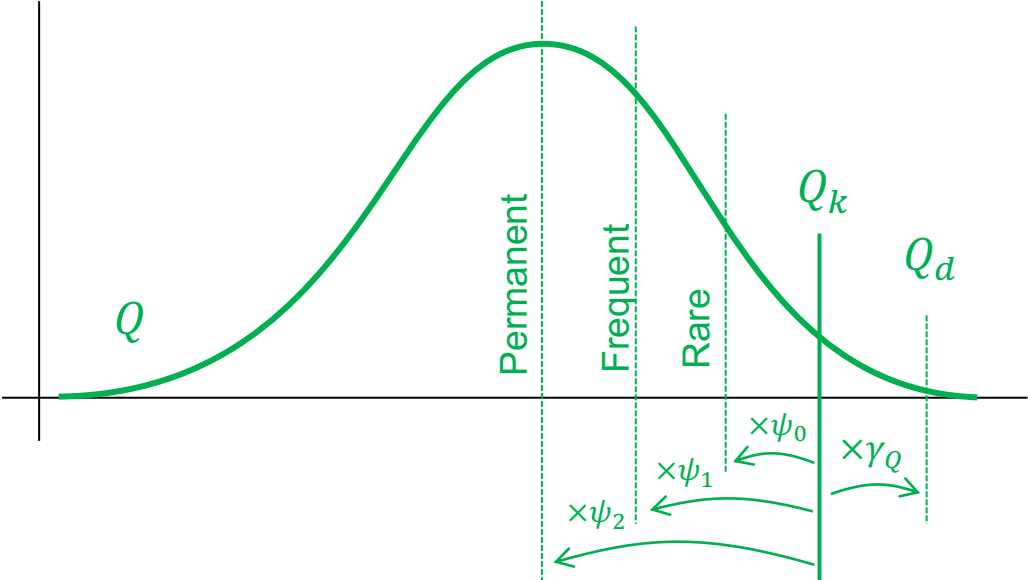
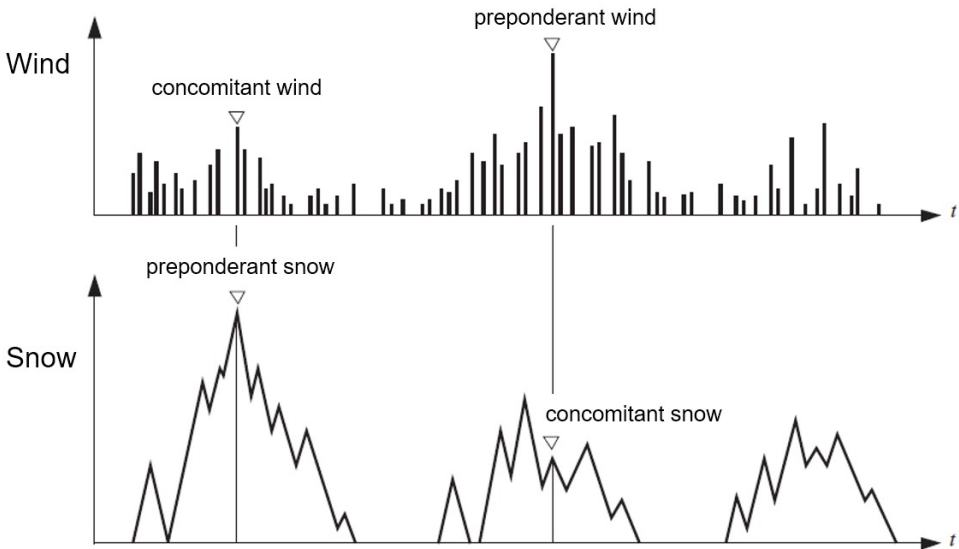

- Turkstra’s rule: check with one preponderant variable load + concomitant variable loads

# Load combinations

- ULS (permanent and variable)

$$\gamma_G G_k + \gamma_{Q1} Q_{k1} + \sum \psi_{0i} Q_{ki}$$

- ULS (accidental)

$$G_k + A_d + \sum \psi_{2i} Q_{ki}$$

- SLS (rare)

$$G_k + Q_{k1} + \sum \psi_{0i} Q_{ki}$$

- SLS (frequent)

$$G_k + \psi_{11} Q_{k1} + \sum \psi_{2i} Q_{ki}$$

- SLS (quasi-permanent)

$$G_k + \psi_{2i} Q_{ki}$$

$i \geq 2$   
(concomitant loads)

**SIA260 Annex A Table 2 (buildings)**

| Actions  | $\psi_0$     | $\psi_1$      | $\psi_2$       |
|--|--------------|---------------|----------------|
| <b>Charges utiles dans les bâtiments</b>         |              |               |                |
| – Catégorie A Locaux habitables                  | 0,7          | 0,5           | 0,3            |
| – Catégorie B Locaux administratifs              | 0,7          | 0,5           | 0,3            |
| – Catégorie C Locaux de réunion                  | 0,7          | 0,7           | 0,6            |
| – Catégorie D Locaux de vente                    | 0,7          | 0,7           | 0,6            |
| – Catégorie E Entrepôts                          | 1,0          | 0,9           | 0,8            |
| <b>Charges dues au trafic dans les bâtiments</b> |              |               |                |
| – Catégorie F Véhicules en dessous de 3,5 t      | 0,7          | 0,7           | 0,6            |
| – Catégorie G Véhicules de 3,5 t à 16 t          | 0,7          | 0,5           | 0,3            |
| – Catégorie H Toits                              | 0            | 0             | 0              |
| Charges de neige                                 | $1 - 60/h_0$ | $1 - 250/h_0$ | $1 - 1000/h_0$ |
| Forces dues au vent                              | 0,6          | 0,5           | 0              |
| Effets de la température                         | 0,6          | 0,5           | 0              |
| <b>Actions du terrain de fondation</b>           |              |               |                |
| – Poussée des terres                             | 0,7          | 0,7           | 0,7            |
| – Pression hydraulique                           | 0,7          | 0,7           | 0,7            |

**SIA260 Annex B Table 6 (road bridges)**

| Actions   | $\psi_0$ | $\psi_1$ | $\psi_2$ |
|---|----------|----------|----------|
| <b>Charges verticales</b>   |          |          |          |
| – Modèle de charge 1  | 0,75     | 0,75     | 0        |
| – Modèle de charge 3  | 0        | 0        | 0        |
| Forces horizontales <sup>1)</sup>   | 0,75     | 0,75     | 0        |
| Charges de neige <sup>2)</sup>  | 0,6      | 0,2      | 0        |
| Forces dues au vent   | 0,6      | 0,2      | 0        |
| Effets de la température  | 0,6      | 0,6      | 0,5      |
| <b>Actions du terrain de fondation</b>  |          |          |          |
| – Poussée des terres  | 0,7      | 0,7      | 0,7      |
| – Pression hydraulique  | 0,7      | 0,7      | 0,7      |
| <sup>1)</sup> On admettra que les forces horizontales agissent simultanément avec le modèle de charge 1.        |          |          |          |
| <sup>2)</sup> Les charges de neige ne seront considérées comme action concomitante que pour les ponts couverts. |          |          |          |

*Note: prestress load omitted here for simplicity*

# 5. ACTIONS

# Generalities

- What follows is not a complete summary – just a taste
- Actions are specified in standard SIA 261

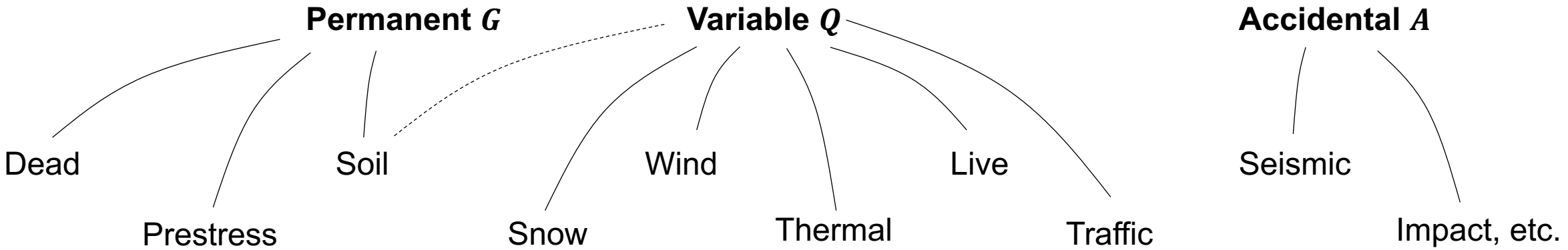

# Dead load

- Self-weight of structural materials (concrete, steel, timber, etc.)
- Quasi-permanent non-structural material (roofing, partition walls, etc.) sometimes called “Superimposed Dead Load” (SDL)
- Calculate based on mean density and nominal volume

SIA261 Annex A Table 28

| Matériau                                 | Charge volumique kN/m <sup>3</sup> | Matériau  | Charge volumique kN/m <sup>3</sup> |
|--|------------------------------------|---|------------------------------------|
| Aluminium                                | 27                                 | Maçonnerie montée sans crépi                    |                                    |
| Acier                                    | 78,5                               | briques de terre cuite pleines                  | 18                                 |
| Béton                                    |                                    | briques de terre cuite perforées                | 13                                 |
| non armé                                 | 24                                 | briques à haute isolation phonique              | 17                                 |
| armé                                     | 25                                 | briques apparentes perforées                    | 15                                 |
| Béton léger (à déterminer de cas en cas) |                                    | agglomérés de béton pleins                      | 22                                 |
| Bois                                     |                                    | agglomérés de béton perforés                    | 18                                 |
| résineux en général                      | 5                                  | agglomérés isolants phoniquement                | 20                                 |
| feuillus en général                      | 7,5                                | briques silico-calcaires pleines                | 20                                 |
| bois résineux collés                     | 5                                  | briques silico-calcaires perforées              | 18                                 |
| panneaux en bois aggloméré               | 8                                  | agglomérés de béton cellulaire, qualité normale | 6                                  |
| Maçonnerie en pierre                     |                                    | agglomérés de béton cellulaire, haute qualité   | 7                                  |
| moellons (calcaire)                      | 24                                 | briques de verre pleines                        | 25                                 |
| granite                                  | 27                                 | briques de verre creuses                        | 14                                 |
| basalte                                  | 30                                 | plaques d'argile cellulaire                     | 12                                 |
| molasse, grès                            | 24                                 | plaques de plâtre                               | 12                                 |
| Enduits et crépis                        |                                    | Revêtements de sols                             |                                    |
| mortier de chaux                         | 19                                 | dallage en céramique                            | 20                                 |
| mortier de ciment                        | 22                                 | pierre naturelle                                | 30                                 |
| mortier de plâtre                        | 12                                 | parquet en bois collé                           | 8                                  |
| crépis muraux extérieurs                 | 18                                 | linoléum  | 15                                 |
| crépis muraux intérieurs                 | 14                                 | Revêtements bitumineux                          |                                    |
|  |                                    | asphalte coulé                                  | 24                                 |
|  |                                    | revêtement bitumineux (HMT)                     | 24                                 |

SIA261 Annex A Table 29

| Couverture, revêtement                        | Charge de surface kN/m <sup>2</sup> | Couverture, revêtement  | Charge de surface kN/m <sup>2</sup> |
|---|-------------------------------------|---|-------------------------------------|
| Ciment armé de fibres                         | 0,18                                | Sous-toitures   |                                     |
| Tôles profilées, $h = 80$ mm, $d = 0,8$ mm    |                                     | bardeaux  | 0,10                                |
| en acier                                      | 0,12                                | panneaux de fibres durs   | 0,05                                |
| en aluminium                                  | 0,04                                | panneaux en ciment armé de fibres   | 0,12                                |
| Couverture d'ardoise en ciment armé de fibres |                                     | lambris de 24 mm, y.c. une couche de carton bitumé ou une feuille plastique | 0,14                                |
| recouvrement simple                           | 0,23                                | Vitrage, y compris châssis  |                                     |
| recouvrement double                           | 0,30                                | verre normal de 5 mm  | 0,25                                |
| Tuiles en terre cuite, y compris lattis       |                                     | verre armé de 6 mm  | 0,35                                |
| tuiles plates, recouvrement double            | 0,75                                | Gravillon, par 10 mm d'épaisseur  | 0,20                                |
| tuiles flamandes                              | 0,47                                | Carton bitumé, par couche   | 0,02                                |
| Tuiles en béton, y compris lattis             |                                     | Feuille plastique   | 0,02                                |
| tuiles plates                                 | 0,55                                | Enduits de mortier  | 0,02                                |
| tuiles flamandes                              | 0,48                                |   |                                     |

SIA261 Annex A Table 30

| Matériau / denrée          | Charge volumique kN/m <sup>3</sup> | Angle de talus ° | Matériau / denrée                       | Charge volumique kN/m <sup>3</sup> | Angle de talus ° |
|----------------------------|------------------------------------|------------------|---|------------------------------------|------------------|
| Terres et ballast          |                                    |                  | Liquides                                |                                    |                  |
| sable                      | 15                                 | 35               | essence                                 | 7,3                                |                  |
| tout venant, mélangé       | 20                                 | 27               | pétrole, diesel et mazout               | 8,5                                |                  |
| ballast, concassé          | 18                                 | 35               | goudron de houille, bitume              | 12                                 |                  |
| terre, sèche               | 16                                 | 40 à 45          | huile minérale de graissage             | 9,2                                |                  |
| terre, humide              | 21                                 | 20 à 25          | huile végétale                          | 9,5                                |                  |
| gravats (en moyenne)       | 14                                 | 30 à 35          | Papier                                  |                                    |                  |
| Combustibles               |                                    |                  | livres sur étagères                     | 6                                  |                  |
| houille                    | 9                                  | 35               | papier empilé                           | 11                                 |                  |
| briquettes, en vrac        | 9                                  | 30               | papier en rouleaux                      | 15                                 |                  |
| briquettes, empilées       | 13,5                               |                  | Fourrage                                |                                    |                  |
| coke, en vrac              | 5                                  |                  | céréales en vrac                        | 7,5                                | 30               |
| bois en bûches :           |                                    |                  | pommes de terre, betteraves fourragères | 7                                  | 30               |
| conifère, sec              | 4,4                                | 45               | foin et paille en vrac                  | 1,5                                |                  |
| conifère, humide           | 6,5                                | 45               | herbe en vrac                           | 3,5                                |                  |
| feuillu, sec               | 7                                  | 45               | Fumier                                  | 9,5                                |                  |
| feuillu, humide            | 10                                 | 45               | Denrées alimentaires                    |                                    |                  |
| bois en copeaux, en vrac   | 1,5                                | 25               | farine en vrac                          | 6                                  | 35               |
| bois en copeaux, compacté  | 2,5                                | 45               | sucre en vrac                           | 9,5                                | 35               |
| Liants                     |                                    |                  | sel en vrac                             | 12                                 | 40               |
| chaux hydraulique          | 12                                 | 25               | sel en sacs                             | 10                                 |                  |
| ciment en silo             | 16                                 | 30               |   |                                    |                  |
| ciment en sacs             | 12                                 |                  |   |                                    |                  |
| clinker de ciment, en vrac | 17                                 | 30               |   |                                    |                  |

# Prestress load

- Considered permanent load
- Given its own safety factor  $\gamma_p$

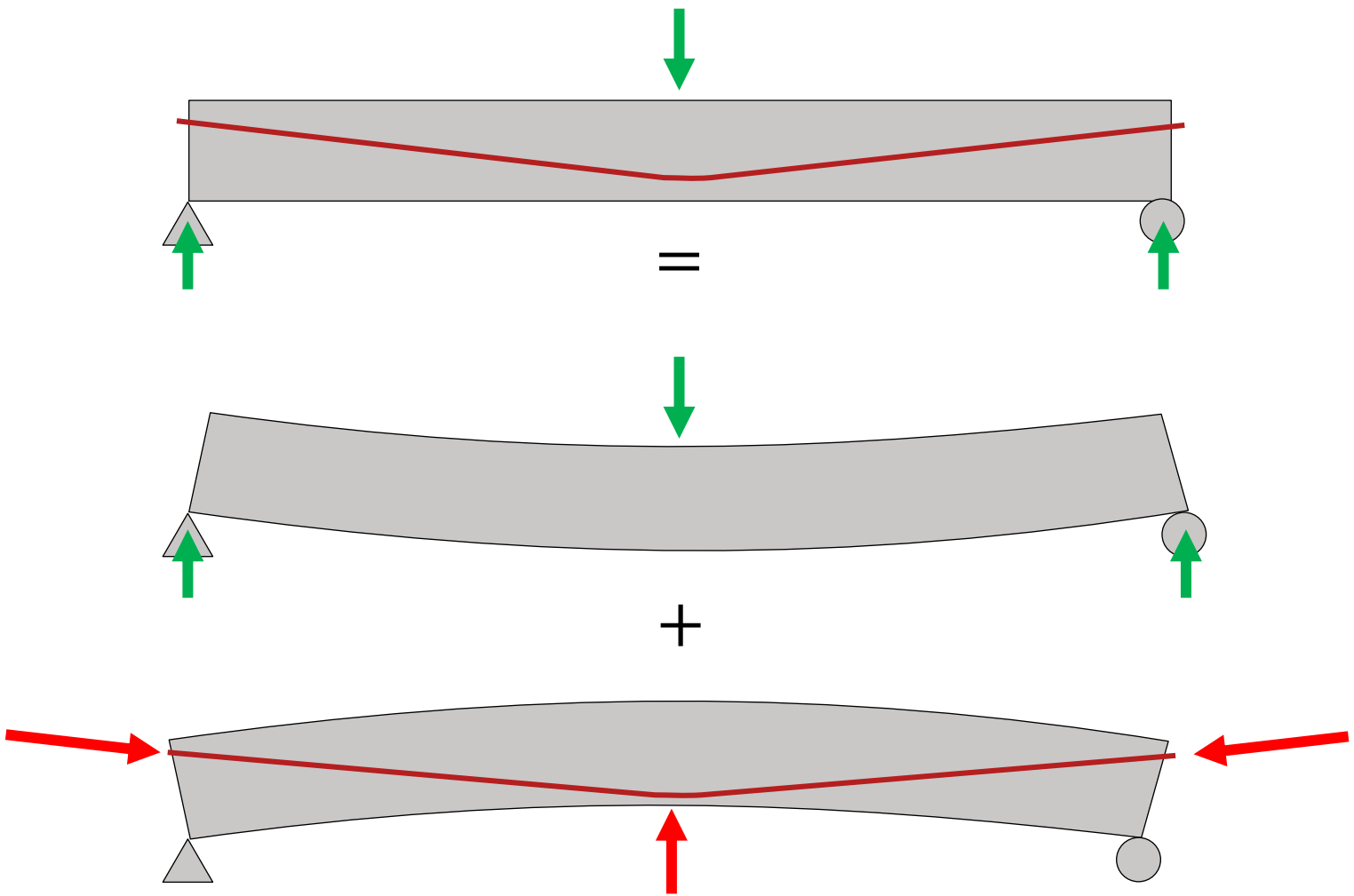

# Soil load

- Usually coordinated with geotechnical engineer
- Effective load depends on weight of soil and friction angle

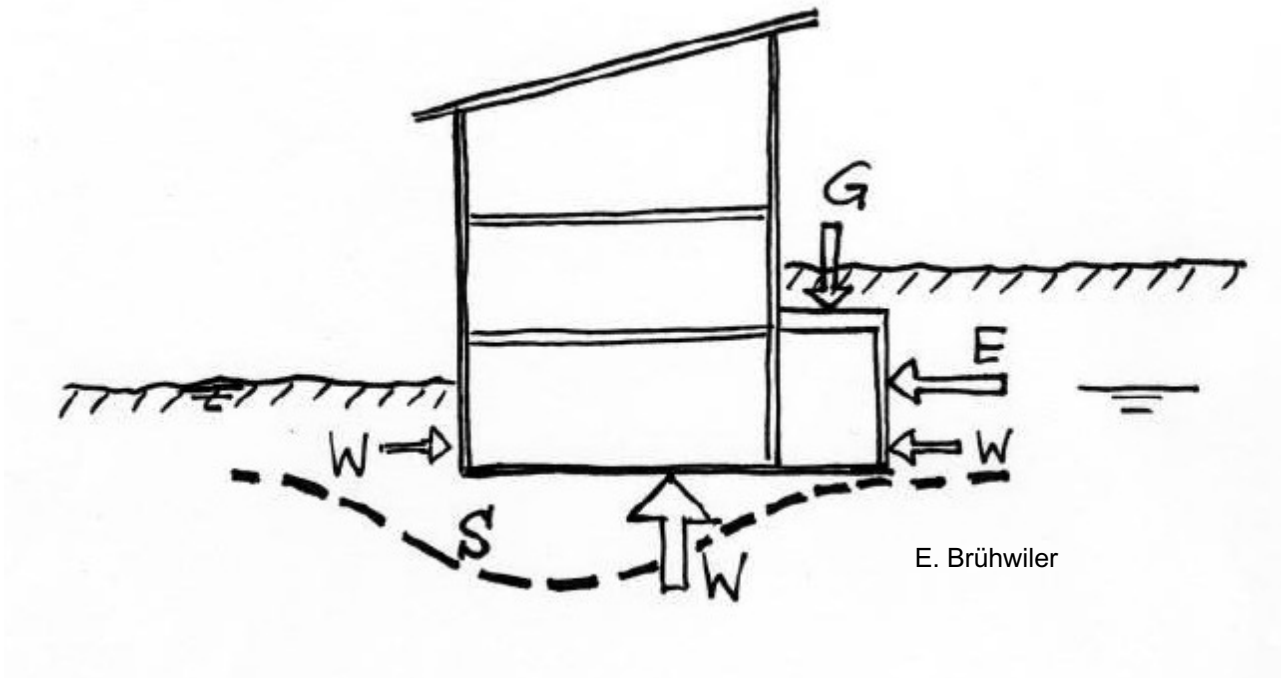

$G$  = Surcharge

$E$  = Lateral earth pressure

$W$  = Hydraulic pressure

$S$  = Soil settlement

# Snow load

- Generally a function of altitude
- Snow piling due to wind and shape of roof must be considered

$$q_k = \mu_i \cdot C_e \cdot C_T \cdot s_k$$

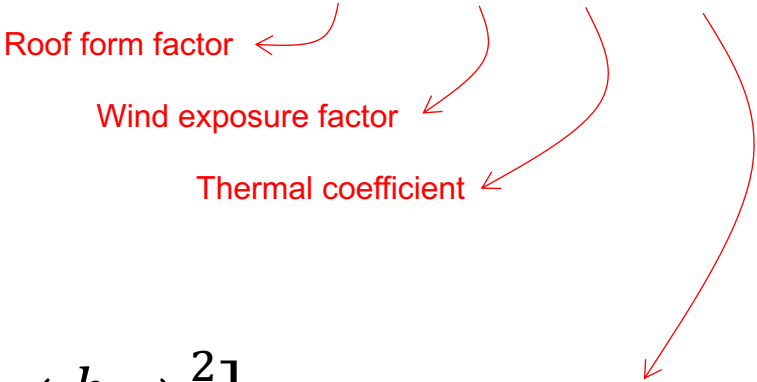

$$s_k = \left[ 1 + \left( \frac{h_o}{350} \right)^2 \right] \cdot 0.4 \text{ kPa} \geq 0.9 \text{ kPa}$$

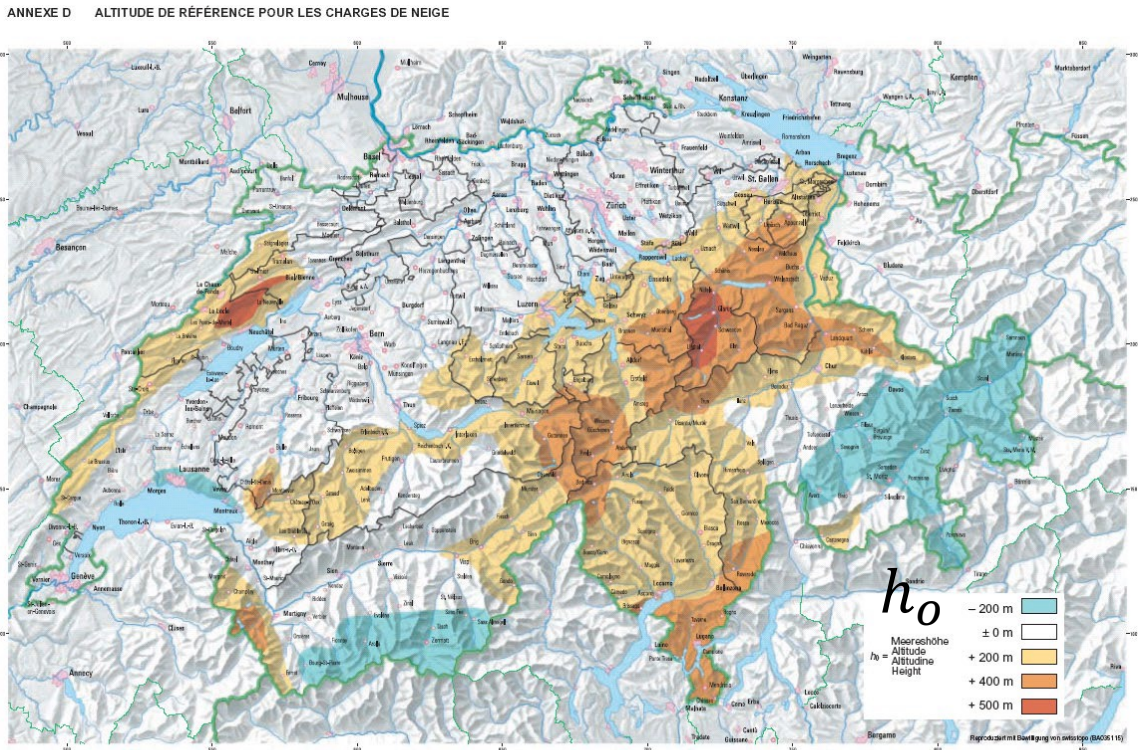

ANNEXE D ALTITUDE DE RÉFÉRENCE POUR LES CHARGES DE NEIGE

Anhang  
Annexe  
Appendice  
Annex

Bezugshöhe  $h_o$   
Altitude de référence  $h_o$   
Altitudine di riferimento  $h_o$   
Reference Height  $h_o$

(nicht anwendbar auf Bauwerke über 2000 m Meereshöhe)  
(pas applicable pour les constructions situées au-dessus de 2000 m d'altitude)  
(non applicabile a costruzioni ubicate sopra 2000 m sul mare)  
(not applicable for construction works at heights greater than 2000 m)

1:50000

SIA 261, Copyright © 2003 by SIA Zurich

105

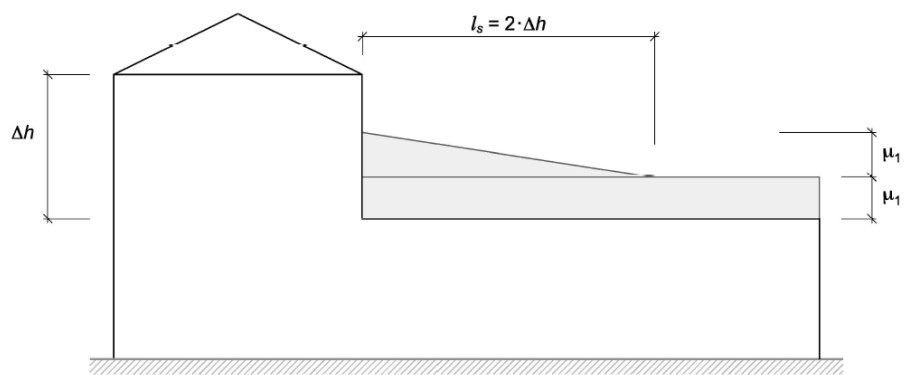

# Wind load

- Pressure derives from wind speed

$$q = \frac{1}{2} \cdot \rho \cdot v^2$$

- Dynamic pressure is function of height

$$q_p = c_h \cdot q_{p0}$$

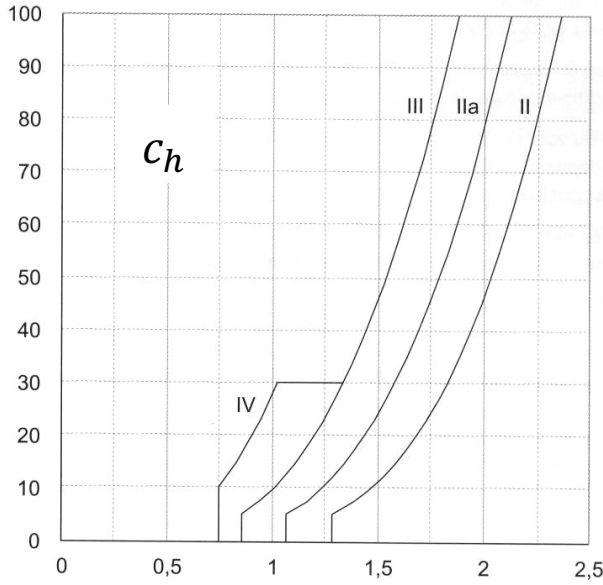

| Catégorie de terrain | Exemples               |
|----------------------|------------------------|
| II                   | rive lacustre          |
| IIa                  | grande plaine          |
| III                  | localité, milieu rural |
| IV                   | zone urbaine étendue   |

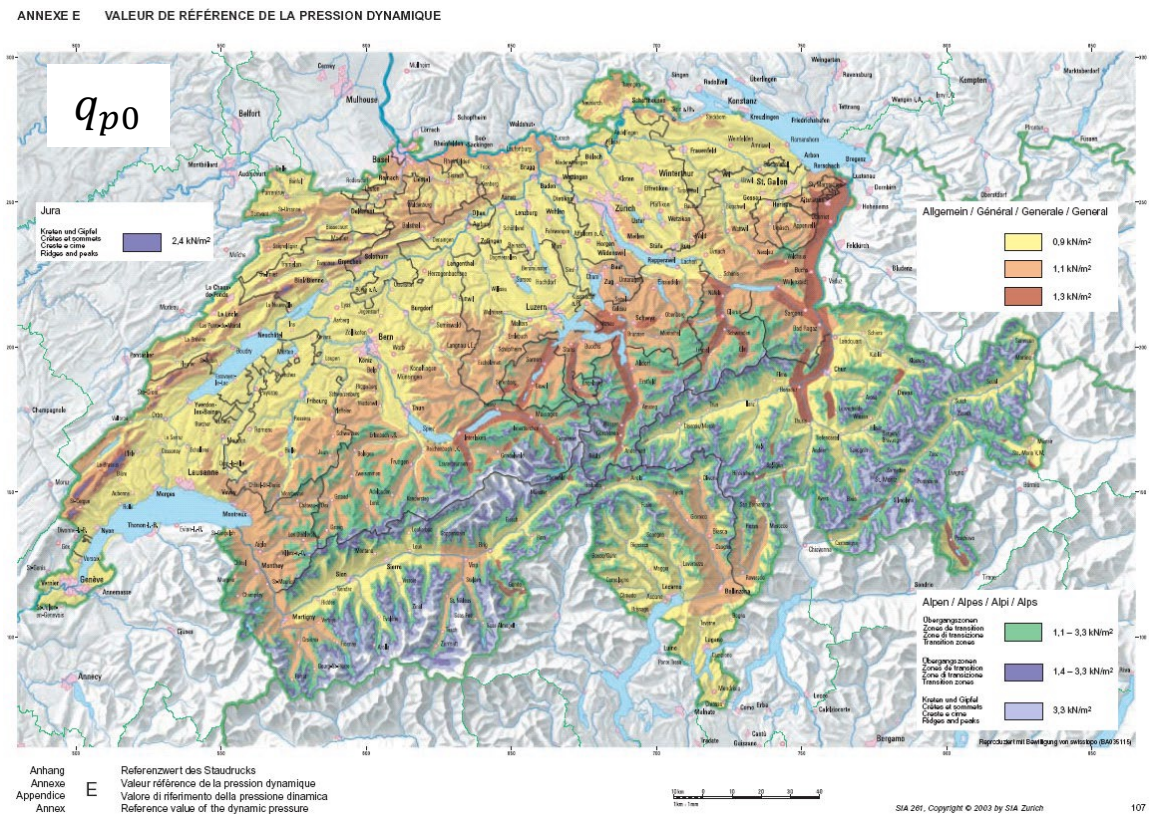

# Wind load

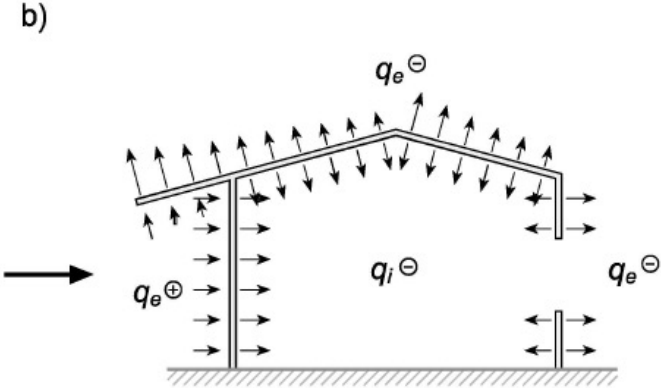
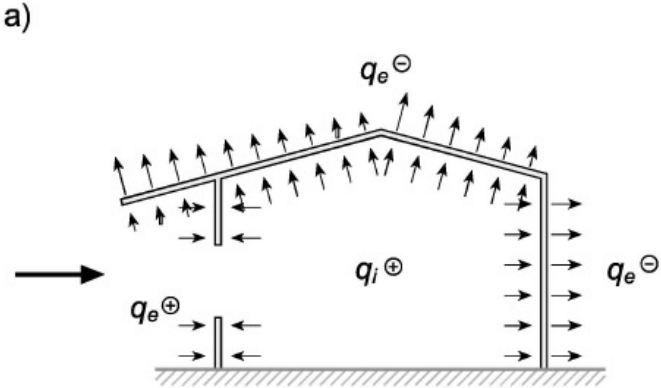

Local effect (e.g., cladding design)

$$Q_{ek} = c_d \cdot c_{pe} \cdot q_p \cdot A_{ref}$$

$$Q_{ik} = c_d \cdot c_{pi} \cdot q_p \cdot A_{ref}$$

Dynamic factor

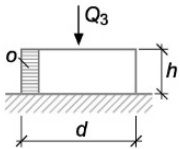

Example:

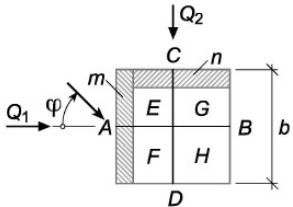

Global effect (e.g., structural stability)

$$Q_k = c_{red} \cdot c_d \cdot c_f \cdot q_p \cdot A_{ref}$$

Reduction factor for large areas

Tableau 31 Coefficients pour  $h : b : d = 0,3 : 1 : 1$  à  $0,05 : 1 : 1$ , toit plat

| $\varphi$ | Coefficients de pression |       |       |       |       |       |       |       |                   |       |   |                |       | Coefficients de force |          |          |             |             |             |
|-----------|--------------------------|-------|-------|-------|-------|-------|-------|-------|-------------------|-------|---|----------------|-------|-----------------------|----------|----------|-------------|-------------|-------------|
|           | $c_{pe}$                 |       |       |       |       |       |       |       | $c_{pe}$          |       | $c_{pi}$                                |                |       | $c_{r1}$              | $c_{r2}$ | $c_{r3}$ |             |             |             |
|           | Surface d'application    |       |       |       |       |       |       |       | Surface localisée |       | Ouvertures prépondérantes sur les côtés |                |       | Surface de référence  |          |          |             |             |             |
|           | A                        | B     | C     | D     | E     | F     | G     | H     | m                 | n     | o                                       | rép.           | A     | B                     | C        | D        | $b \cdot h$ | $d \cdot h$ | $d \cdot b$ |
| 0°        | 0,7                      | -0,25 | -0,35 | -0,35 | -0,5  | -0,5  | -0,25 | -0,25 | -0,85             | -0,45 | -0,8                                    | 0,15/<br>-0,21 | 0,7   | -0,25                 | -0,35    | -0,35    | 0,95        | 0           | -0,38       |
| 15°       | 0,55                     | -0,25 | -0,2  | -0,35 | -0,5  | -0,55 | -0,25 | -0,3  | -0,85             | -0,45 | -1,0                                    | $\pm 0,15$     | 0,55  | -0,25                 | -0,2     | -0,35    | 0,8         | 0,15        | -0,4        |
| 45°       | 0,4                      | -0,4  | 0,4   | -0,4  | -0,45 | -0,45 | -0,45 | -0,25 | -0,85             | -0,85 | -0,45                                   | $\pm 0,1$      | 0,4   | -0,4                  | 0,4      | -0,4     | 0,8         | 0,8         | -0,4        |
| 90°       | -0,35                    | -0,35 | 0,7   | -0,25 | -0,5  | -0,25 | -0,5  | -0,25 | -0,45             | -0,85 | 0,45                                    | $\pm 0,15$     | -0,35 | -0,35                 | 0,7      | -0,25    | 0           | 0,95        | -0,38       |
|           | $\hat{c}_{pe} = -2,0$    |       |       |       |       |       |       |       |                   |       |   |                |       | $c_{fr} = 0$          |          |          |             |             |             |

# Wind load

- In tall buildings a wind consultant usually provides input on design forces and pressures, as well as vibration criteria
- Phenomenon of “vortex shedding”

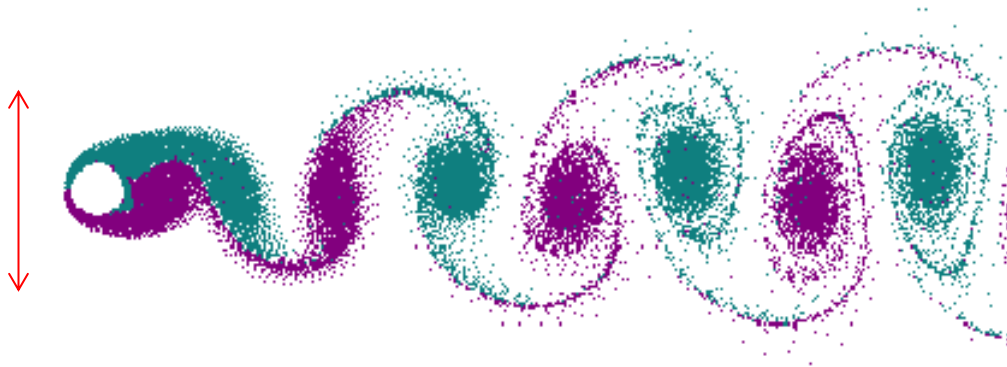

Wikipedia

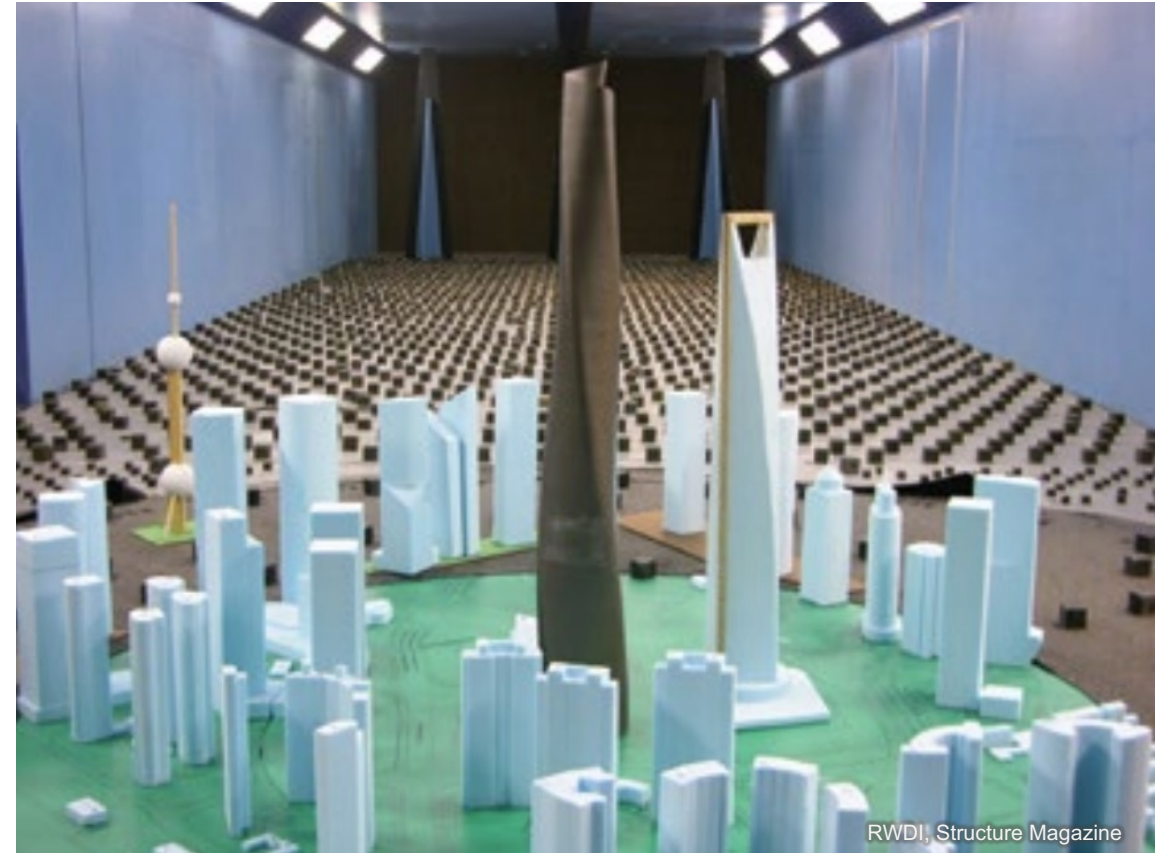

RWDI, Structure Magazine

# Thermal load

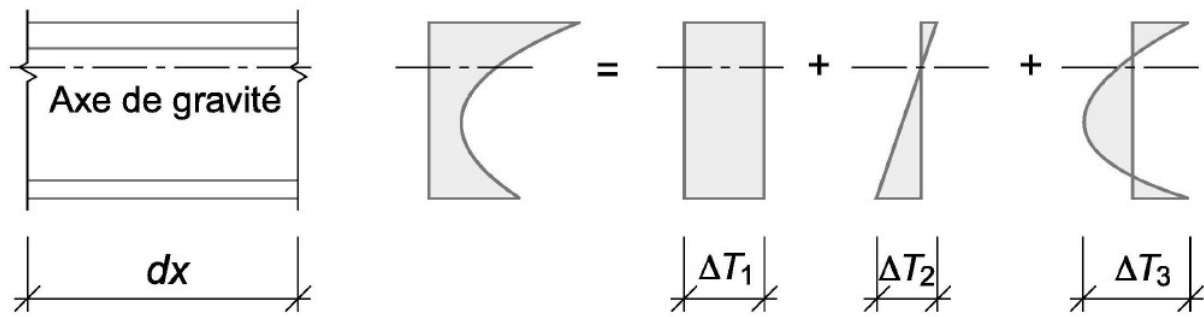

| Mode de construction       | $\Delta T_{1k}$ en °C |
|----------------------------|-----------------------|
| Béton non armé             | ± 15                  |
| Béton armé ou précontraint | ± 20                  |
| Acier                      | ± 30                  |
| Mixte acier-béton          | ± 25                  |
| Bois                       | ± 20                  |
| Maçonnerie                 | ± 15                  |
| Aluminium                  | ± 30                  |

Seasonal variation

Short-term variation (e.g., direct sun)

Nonlinearity (usually ignored)

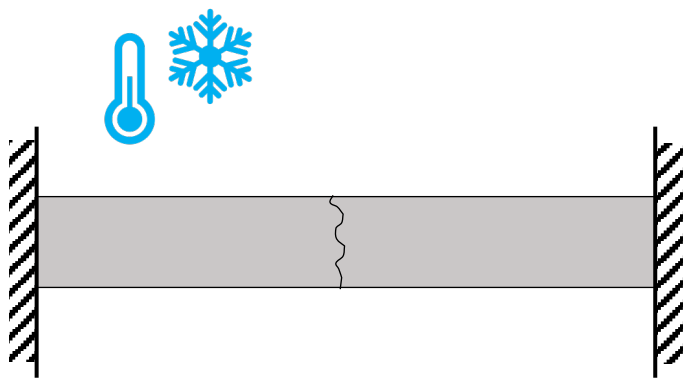

Expansion joints may be needed in monolithic structures

| Type de structure            | Face supérieure plus chaude<br>$\Delta T_{2k}$ en °C | Face supérieure plus froide<br>$\Delta T_{2k}$ en °C |
|------------------------------|--|--|
| Ponts métalliques            | + 10   | - 6  |
| Ponts en béton <sup>1)</sup> |  |  |
| $h \leq 1,0$ m               | + 12   | - 4  |
| $h \geq 3,0$ m               | + 8  | - 3  |
| Ponts de construction mixte  |  |  |
| Dalle                        | + 12   | - 4  |
| Poutre métallique            | 0  | 0  |

<sup>1)</sup>  $h$  = hauteur de la section; pour des hauteurs entre 1 m et 3 m, les valeurs pourront être interpolées linéairement.

# Live load (buildings)

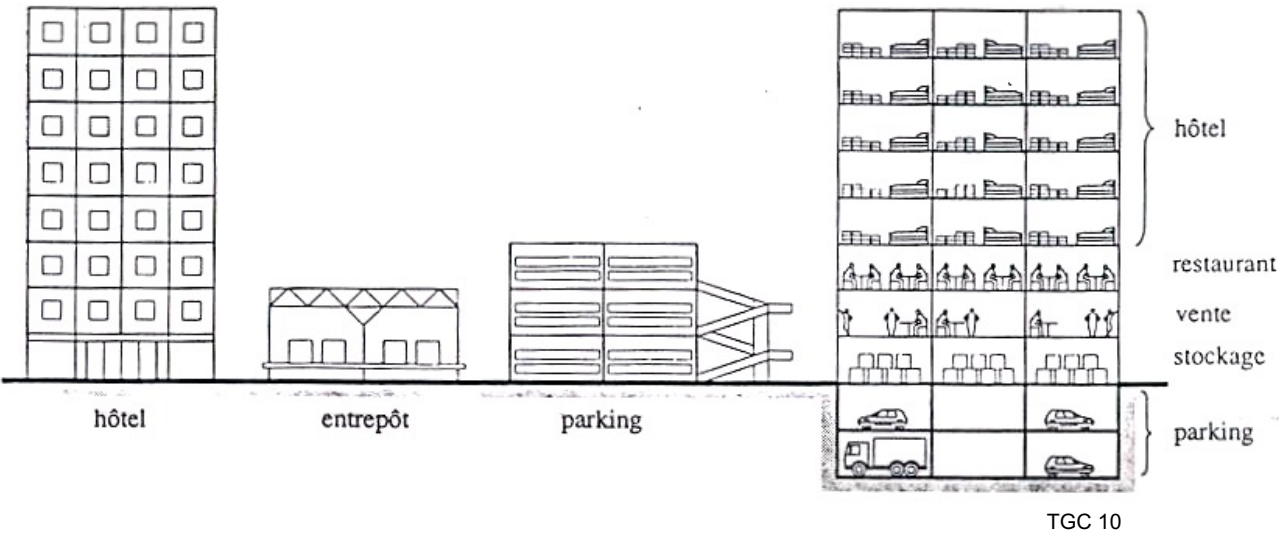

- Consider distributed and/or point loads

SIA261 Table 8

| Catégorie | Genre de surface utile   | Exemples   | $q_k$ en kN/m <sup>2</sup> | $Q_k$ en kN        |
|-----------|--|--|----------------------------|--------------------|
| A         | Surfaces d'habitation  | A1: Locaux dans les immeubles et les maisons d'habitation, services des hôpitaux, chambres d'hôtel, cuisines et toilettes    | 2                          | 2 <sup>1)</sup>    |
|           |  | A2: Balcons  | 3                          | 2 <sup>1)</sup>    |
|           |  | A3: Escaliers  | 4                          | 2 <sup>1)</sup>    |
| B         | Bureaux  |  | 3                          | 2 <sup>1)</sup>    |
| C         | Locaux de réunion  | C1: Surfaces avec tables et chaises  | 3                          | 4 <sup>1)</sup>    |
|           |  | C2: Surfaces avec sièges fixes   | 4                          | 4 <sup>1)</sup>    |
|           |  | C3: Surfaces librement accessibles, surfaces de sport et de jeu, surfaces pouvant accueillir des rassemblements de personnes | 5                          | 4 <sup>1)</sup>    |
| D         | Surfaces de vente  | Grands magasins, commerces   | 5                          | 4 <sup>1)</sup>    |
| E         | Surfaces d'entrepôt et de fabrication  | Entrepôts, bibliothèques et leurs accès, halles de fabrication   | 2) <sup>3)</sup>           | 2) <sup>3)</sup>   |
| F         | Surfaces de stationnement et surfaces accessibles aux véhicules de poids < 3,5 t | Parkings à étages, surfaces de parc, garages   | 2 <sup>3)</sup>            | 20 <sup>3)4)</sup> |
| G         | Surfaces de stationnement et surfaces accessibles aux véhicules de 3,5 t à 16 t  | Rampes d'accès, zones de livraison, zones accessibles aux véhicules du service du feu  | 5 <sup>3)</sup>            | 90 <sup>3)4)</sup> |
| H         | Toitures non accessibles <sup>5)</sup>   | Toits uniquement accessibles pour des travaux d'entretien  | 0,4                        | 1 <sup>1)</sup>    |

<sup>1)</sup> Surface d'application 50 mm x 50 mm ;  $Q_k$  ne doit pas être combiné avec  $q_k$ . Pour les surfaces d'entrepôts équipées d'étagères ou les surfaces accessibles aux engins de levage, on fixera la valeur  $Q_k$  en tenant compte des spécificités du projet.  
<sup>2)</sup> Voir le chiffre 8.2.2.  
<sup>3)</sup> On admettra que  $Q_k$  et  $q_k$  agissent simultanément.  
<sup>4)</sup> Deux charges concentrées  $Q_k/2$  distantes de 1,8 m sur des surfaces d'application de 200 mm x 200 mm.  
<sup>5)</sup> Selon leur utilisation, les toits accessibles aux personnes et aux véhicules seront considérés comme des surfaces des catégories A à G.

# Live load (buildings)

- In general, live load should be applied where it is least favourable (patterning)

*Influence diagram for negative moment in middle span*

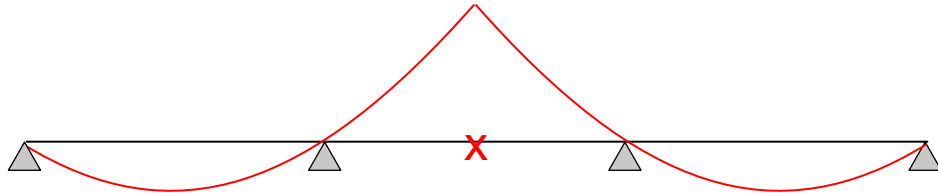

*Load producing worst case negative moment*

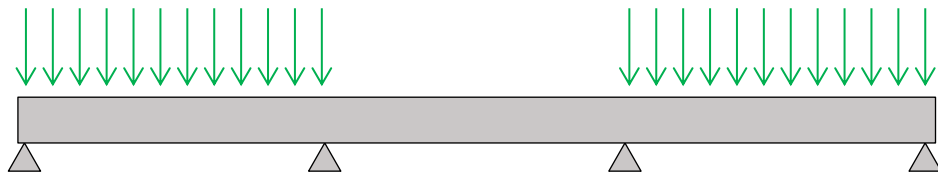

- For tall buildings, it is unlikely that all floors will be fully loaded; the load may be reduced according to the area loaded (live load reduction)
- Different codes take different approaches – SIA261 applies  $\psi_1$  to all but 2 floors

# Traffic loads

- Represented by different idealized static load models (including dynamic effects)
- Braking, accelerating, and centrifugal forces also to be considered
- Similar for rail loads

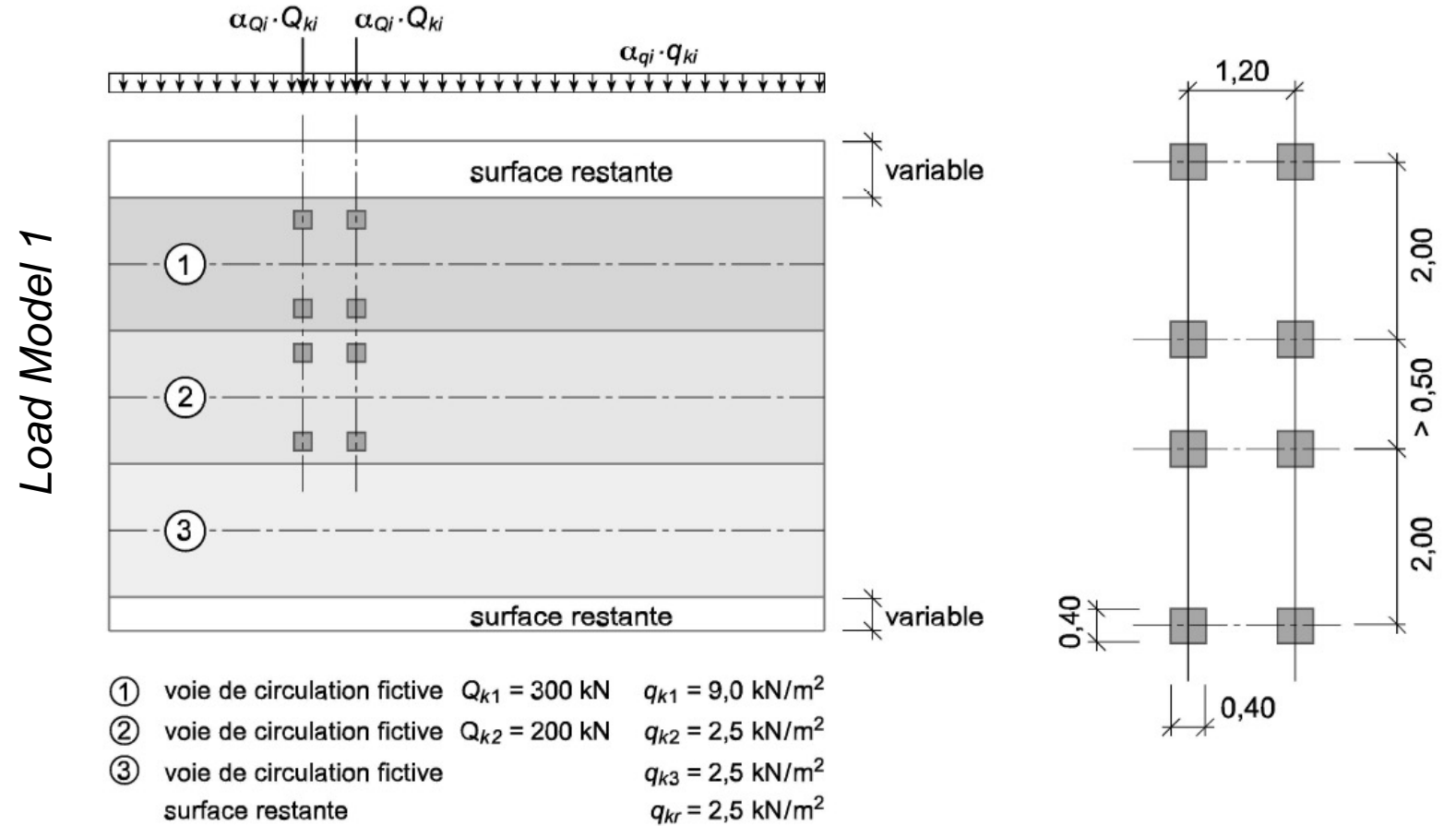

# Seismic load

- Earthquake is considered an accidental action
- Inertial forces from ground shaking are transformed into equivalent static loads

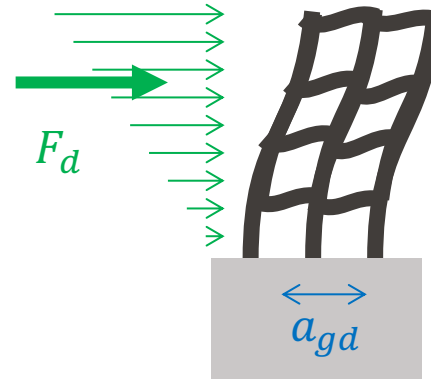

$$F_d \cong \frac{\gamma_f \cdot S_e(T) \cdot W}{q}$$

Importance factor Seismic weight  
Behaviour factor (ductility)

\* Not exactly correct for low and high period, see code!

ANNEXE F ZONES DE RISQUE SISMIQUE

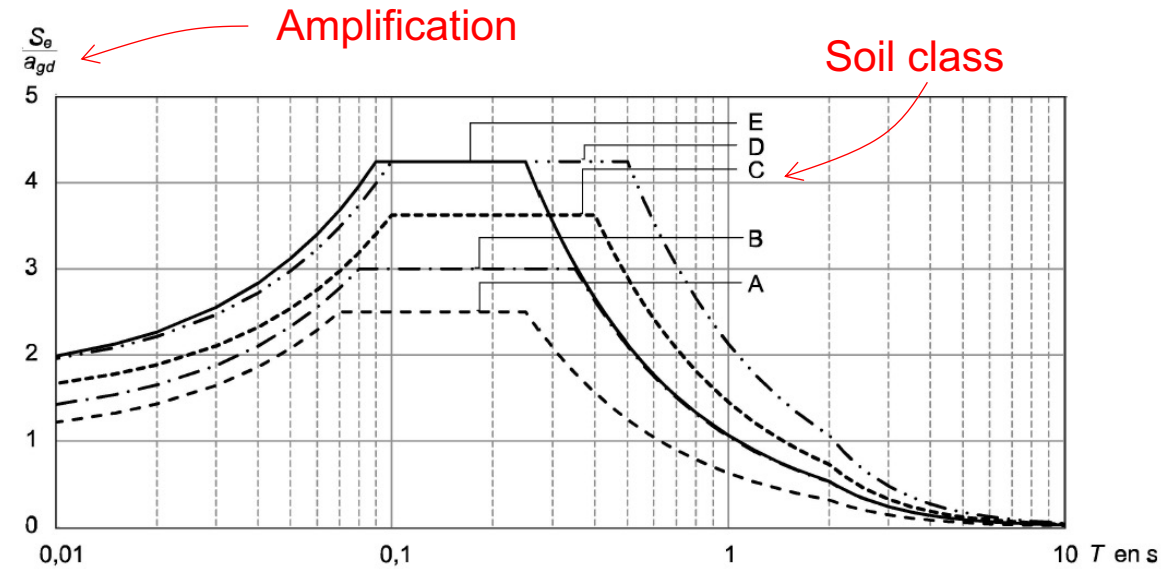
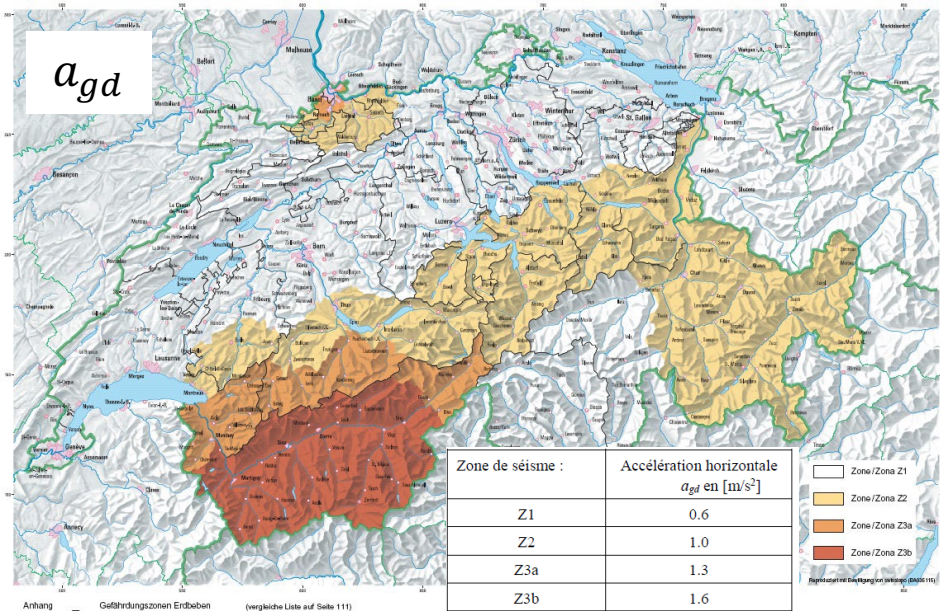

Building fundamental period of vibration

# Impact, fire, explosion

- Preventative measures are usually more cost-effective than designing for very rare hazards
  - E.g., install physical bollards to prevent against vehicle impact
- Impact – Modelled as a static load applied at height of impact
- Fire – Safety ensured by time-based fire rating
- Explosion – Specific considerations where required



# For next class: Exercise on concrete reuse in industry

- [lecture\\_12\\_exercise\\_concrete\\_reuse\\_feasibility.pdf](#)
- [lecture\\_12\\_exercise\\_plans.pdf](#)
- [lecture\\_12\\_exercise\\_calculation\\_tool.xlsx](#)