

ChE-403 Problem Set 2.1

Week 5

Problem 1

Which is the $[1,1,2]$ direction?

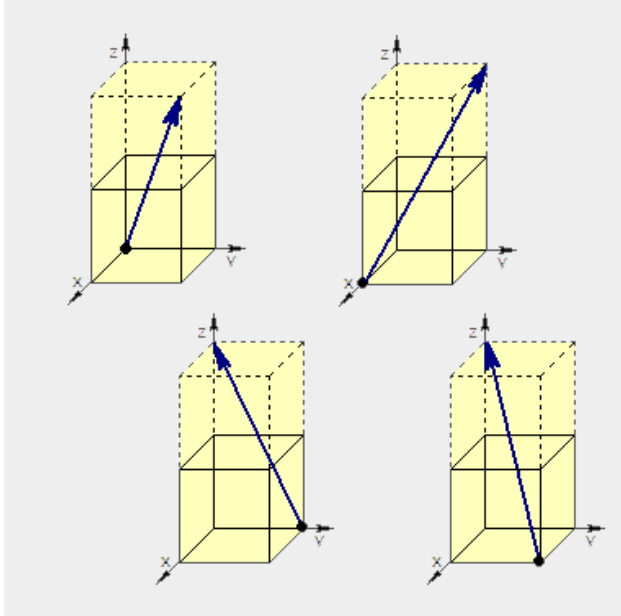

Which is the $(2,1,2)$ plane?

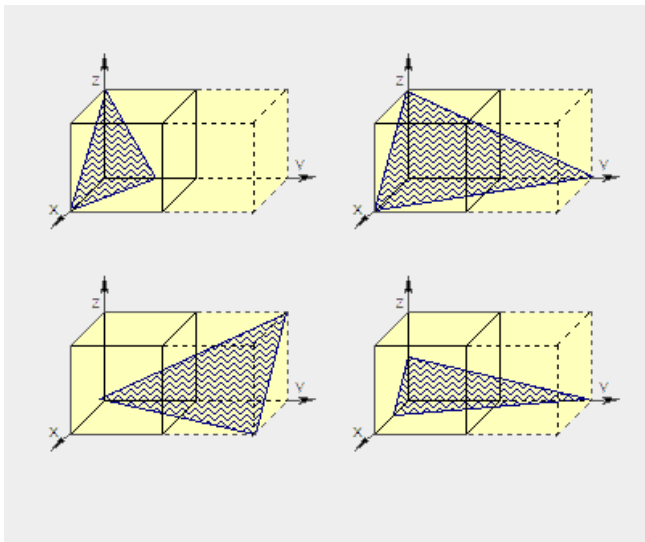

Which is the $(1,1,-1)$ (usually written as $(1,1,\bar{1})$) plane?

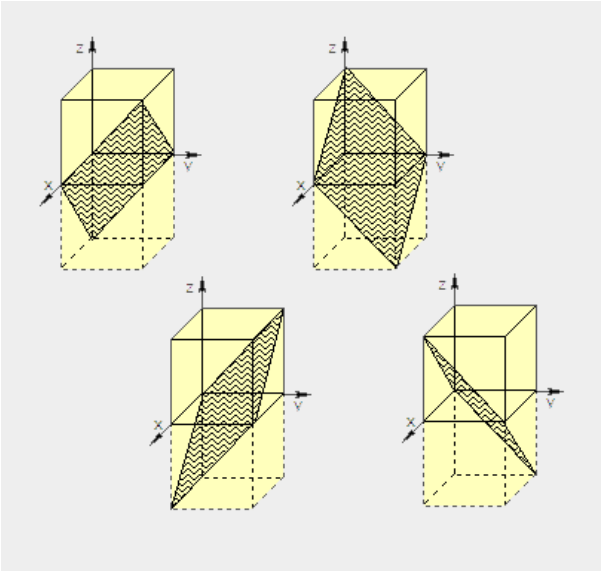

Which is the $(2,2,1)$ plane?

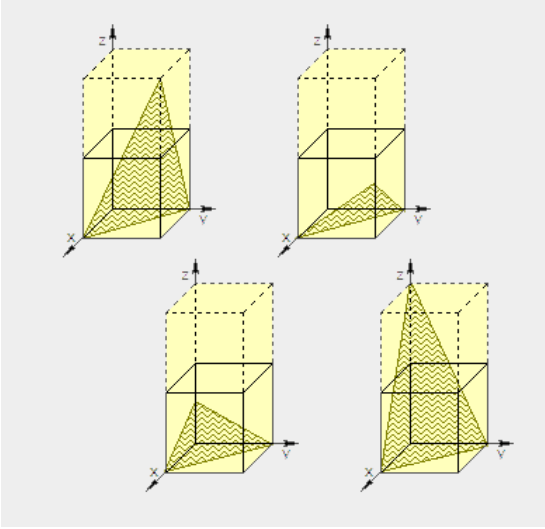

Problem 2

2.1 Can you draw a (1,2,1) plane both in a single (1,1,1) box and as a larger plane that only has unity coordinates (see example below)?

Example: for a plane (2,2,1) we have:

Single (1,1,1) box:

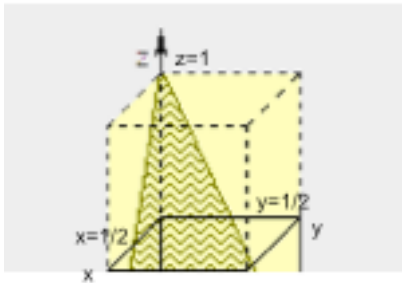

Larger plane with unity coordinates:

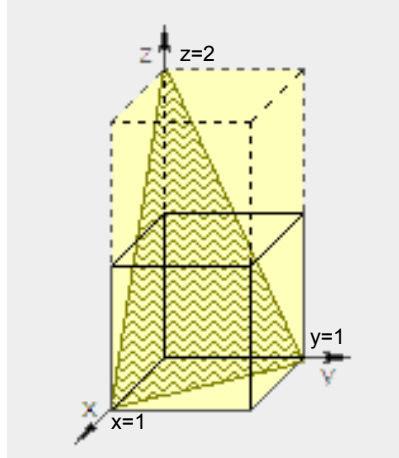

2.2 What would the larger plane (what is shown above to the right) with only unity coordinates be for a (2,1,3) vector? (Don't draw it, just give the coordinates)

Problem 3

Determine the Miller Indices of a plane which is parallel to the x-axis and cuts the y axis at 2 and the z-axis at $1/2$?

Problem 4

Studies on model catalysts (flat metallic surface) revealed that catalytic activity is strongly dependent on which crystallographic plan (hkl) is exposed. For example, Ni(111) and Ni(100) convert ethane into methane, under reductive atmosphere, with different rate (see figure below). A simple geometric approach can help us understand why Ni(111) and Ni(100) have not the same reactivity.

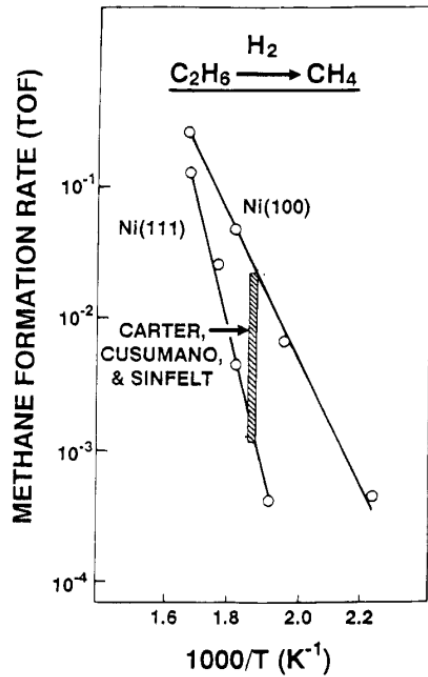

Figure 3. Arrhenius plot for ethane hydrogenolysis reaction on Ni(100) and Ni(111) surfaces at a total reactant pressure P_T of 100 Torr and $\text{H}_2/\text{C}_2\text{H}_6 = 100$.¹² Also shown is the result on supported nickel catalysts at P_T of 175 Torr and $\text{H}_2/\text{C}_2\text{H}_6 = 6.6$.²²

Nickel has a face centered cubic crystal structure (FCC). Each atoms of nickel are equivalent in the bulk and surrounded by 12 neighbors. Now if we cut the unit cell along a plan like (100) a surface appear and Ni_{surf} are no longer equivalent to Ni_{bulk} .

Calculate the density of Ni atom per surface unit and number of neighbors (or lost neighbors) in case of a cut along the (100) and (111) planes.

Hint: Try to find the number of atoms per area by calculating the surface area with a the cell parameter:

