

EPFL

ChE 201: Introduction to Chemical Engineering

2025 Fall Semester
Midterm Exam Solutions
Question 2

Problem 2: Mass Balance, Reactive Systems (35 points)

Instructions:

Acetic acid can be produced via the reaction:

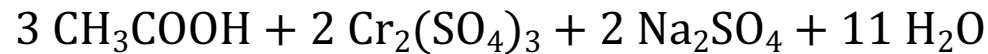
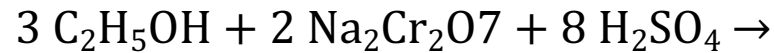

In the recycle system shown in Figure 2, 90% overall conversion of $\text{C}_2\text{H}_5\text{OH}$ is obtained with a recycle flow F4 equal to the feed rate of fresh $\text{C}_2\text{H}_5\text{OH}$ in F1. The feed rates of fresh H_2SO_4 and $\text{Na}_2\text{Cr}_2\text{O}_7$ in F2 are 20% and 10%, respectively, in excess of the stoichiometric amounts required for the fresh $\text{C}_2\text{H}_5\text{OH}$ feed F1. The recycle stream F4 contains 94 mole-% H_2SO_4 and the rest $\text{C}_2\text{H}_5\text{OH}$. All the CH_3COOH is separated and leaves in the top stream F6 of the separator.

Assume a feed rate of fresh $\text{C}_2\text{H}_5\text{OH}$ of 100 mol/h.

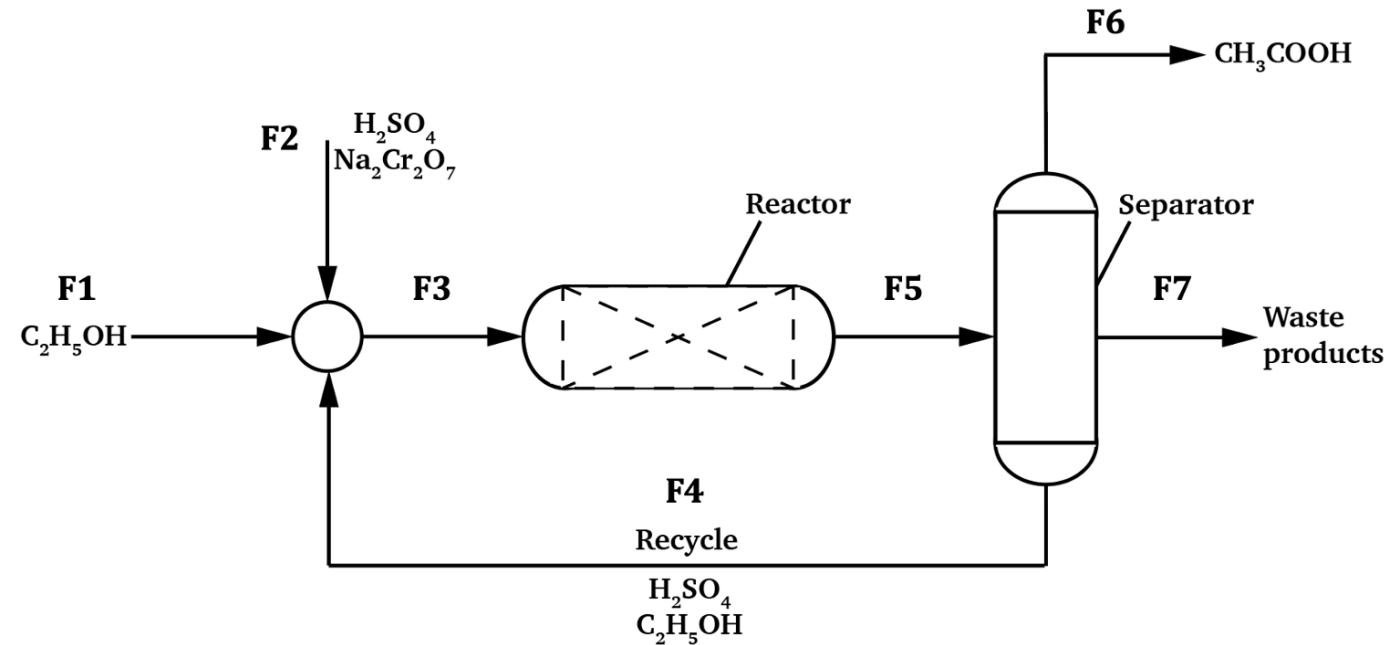
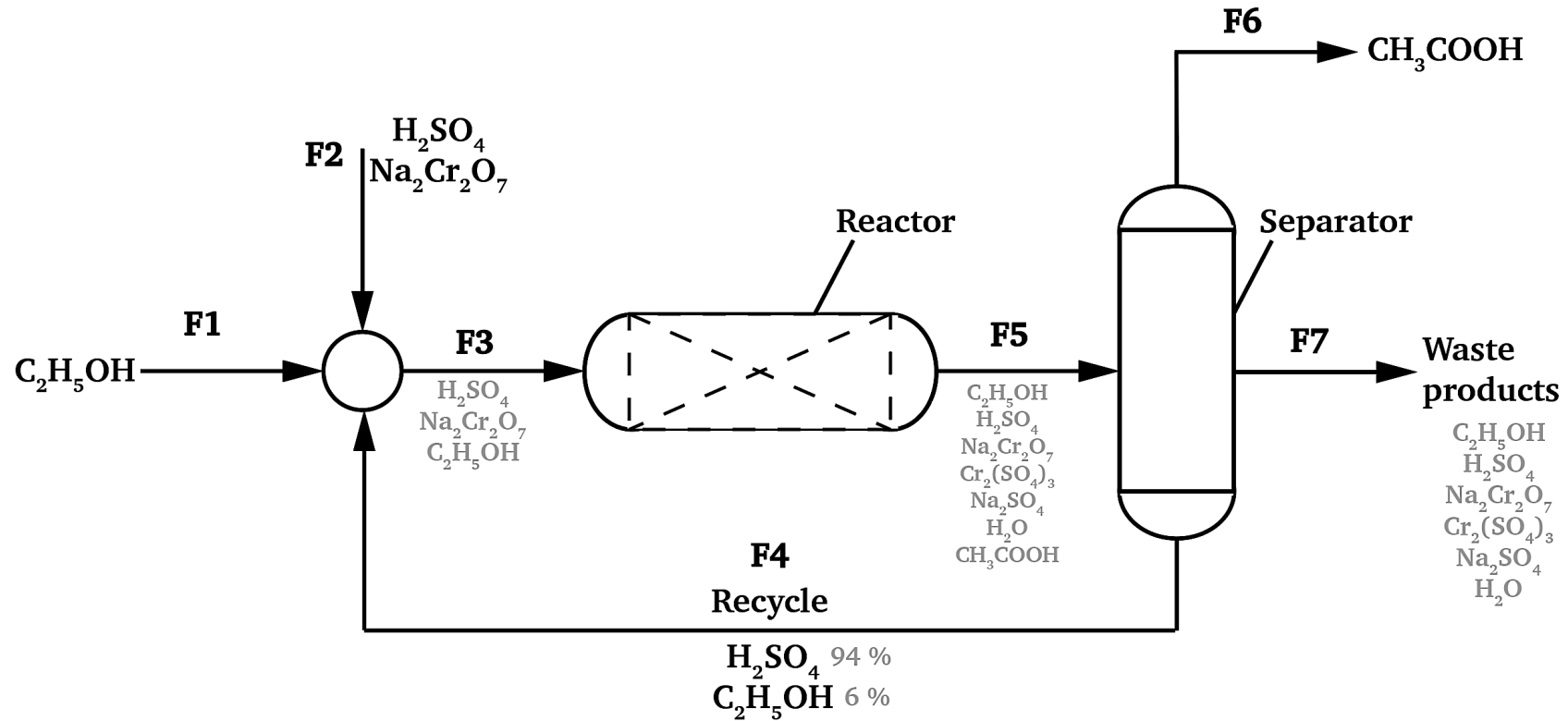

Figure 2.

Problem 2: Mass Balance, Reactive Systems (35 points)

- a) Draw and label a detailed flowchart of the process, recapitulating the composition of each stream. (5 points)



Problem 2: Mass Balance, Reactive Systems (35 points)

b) Calculate the upper product stream flow F6. (8 points)

Basis : 100 mol/h of C_2H_5OH

Stoichiometric calculations:

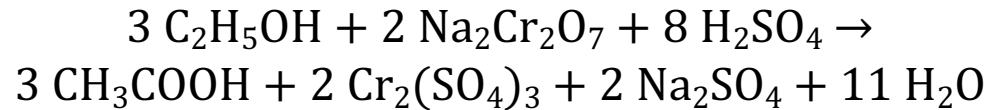

$3 C_2H_5OH \rightarrow 2 Na_2Cr_2O_7$ in the reaction, thus;

$$100 \text{ mol } C_2H_5OH \rightarrow \frac{2}{3} * 100 \text{ mol} = 66.7 \text{ mol } Na_2Cr_2O_7$$

We also add 10% in excess of the stoichiometric amount, thus;

$$F2, x_{Na_2Cr_2O_7} = (100 + 10)\% \times 66.7 \text{ mol} = 73.4 \text{ mol}$$

$3 C_2H_5OH \rightarrow 8 H_2SO_4$ in the reaction, thus;

$$100 \text{ mol } C_2H_5OH \rightarrow \frac{8}{3} * 100 \text{ mol} = 266.7 \text{ mol } Na_2Cr_2O_7$$

We also add 20% in excess of the stoichiometric amount, thus;

$$F2, x_{H_2SO_4} = (100 + 20)\% \times 266.7 \text{ mol} = 320.0 \text{ mol}$$

$$F2 = F2, x_{H_2SO_4} + F2, x_{Na_2Cr_2O_7} = 393.4 \text{ mol}$$

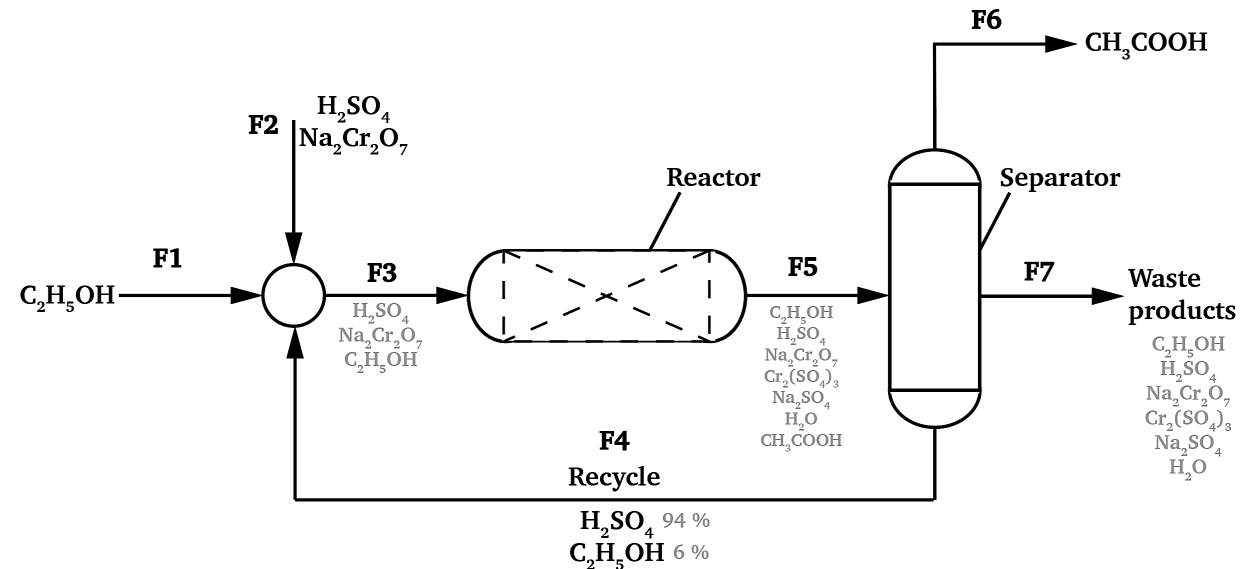

Problem 2: Mass Balance, Reactive Systems (35 points)

b) Calculate the upper product stream flow F6. (8 points)

Overall balance of the system:

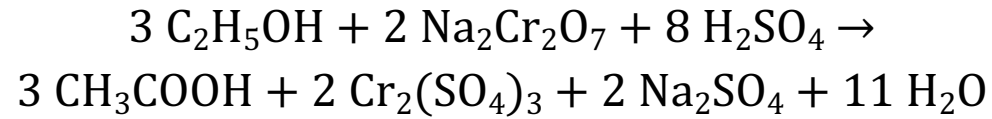

IN - OUT + GENERATION - CONSUMPTION = 0

$$F1 + F2 - 3 \xi - 2 \xi - 8 \xi + 3 \xi + 2 \xi + 2 \xi + 11 \xi - F6 - F7 = 0$$

$$F1 + F2 + 5 \xi = F6 + F7$$

$$\text{C}_2\text{H}_5\text{OH balance} : F1 - 3 \xi$$

$$\text{CH}_3\text{COOH balance} : 3 \xi$$

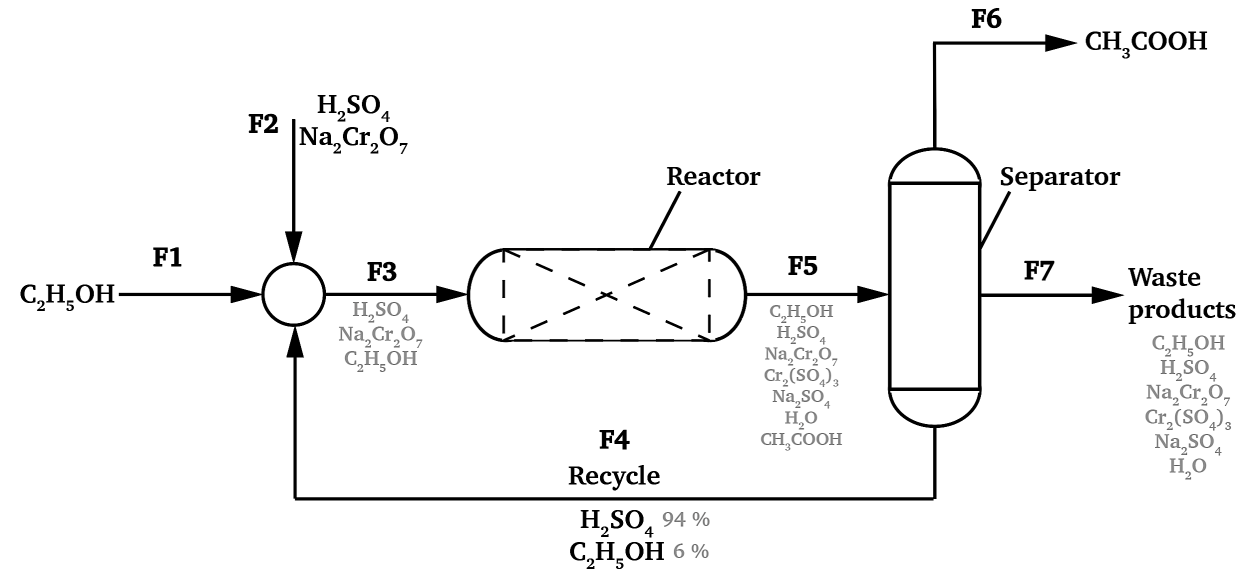

Problem 2: Mass Balance, Reactive Systems (35 points)

b) Calculate the upper product stream flow F6. (8 points)

Overall conversion in the system : 90%

$$\text{Overall conversion} = \frac{\text{Consumed } C_2H_5OH}{\text{Fed } C_2H_5OH}$$

$$90/100 = \frac{3\xi}{F1}$$

$$0.9 * 100 \text{ mol/hr} = 3\xi$$

$$\xi = 30 \text{ mol/hr}$$

Since we have pure CH₃COOH in F6 stream,

CH₃COOH balance : 3 ξ

Upper product stream flow F6:

$$3 * 30 \text{ mol/hr} = 90 \text{ mol/hr } CH_3COOH$$

C₂H₅OH balance : F1 - 3 ξ

CH₃COOH balance : 3 ξ

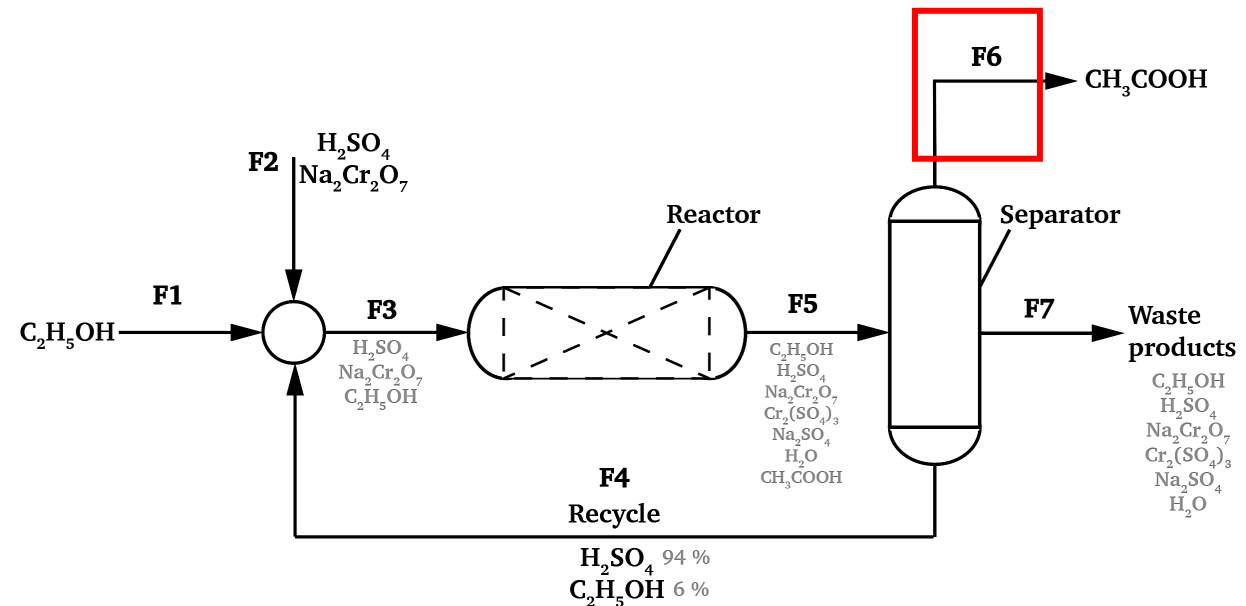

Problem 2: Mass Balance, Reactive Systems (35 points)

c) Compute the flow rate of each stream, as well as the composition of each stream, and fill in the table (15 points).

Mixer balance:

$$F3 = F1 + F2 + F4$$

$$F3 = (100 + 393.4 + 100) \text{ mol/hr}$$

$$F3 = 593.4 \text{ mol/hr}$$

Composition of F3:

$$F3, \omega_{C_2H_5OH} = F1 + 0.06 \times F4$$

$$F3, \omega_{C_2H_5OH} = (100 + 0.06 \times 100) \text{ mol/hr}$$

$$F3, \omega_{C_2H_5OH} = 106 \text{ mol/hr}$$

$$F3, \omega_{H_2SO_4} = F2, \omega_{H_2SO_4} + 0.94 \times F4$$

$$F3, \omega_{H_2SO_4} = (320 + 0.94 \times 100) \text{ mol/hr}$$

$$F3, \omega_{H_2SO_4} = 414 \text{ mol/hr}$$

$$F3, \omega_{Na_2Cr_2O_7} = F2, \omega_{Na_2Cr_2O_7}$$

$$F3, \omega_{Na_2Cr_2O_7} = 73.4 \text{ mol/hr}$$

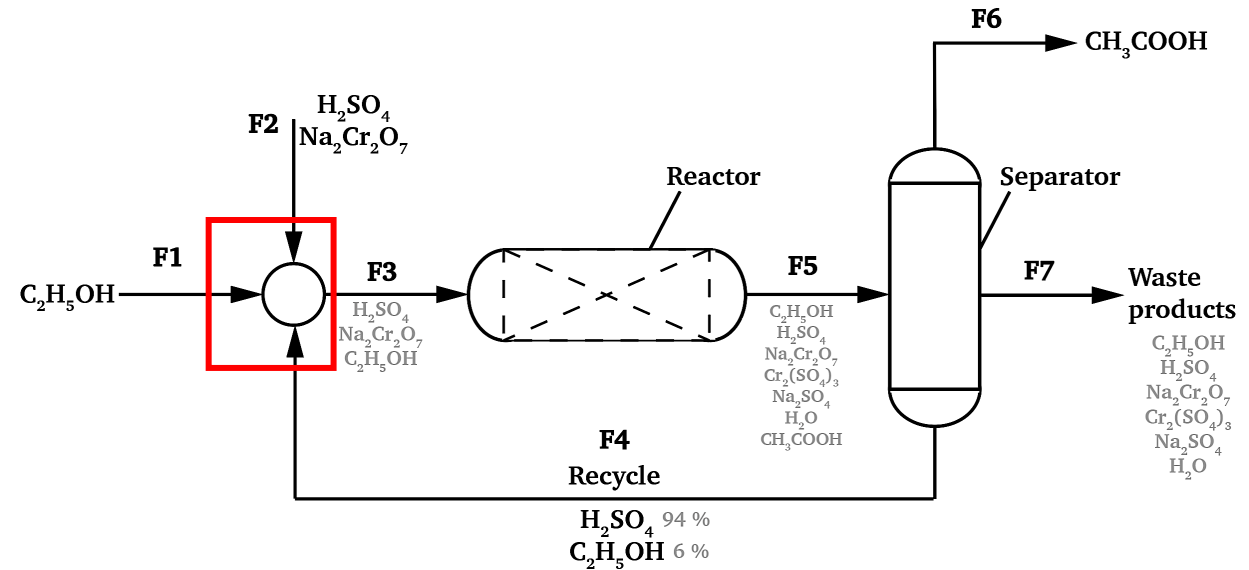

Problem 2: Mass Balance, Reactive Systems (35 points)

c) Compute the flow rate of each stream, as well as the composition of each stream, and fill in the table (15 points).

Reactor balance:

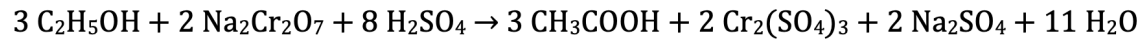

$$F3 - 3\xi - 2\xi - 8\xi + 3\xi + 2\xi + 2\xi + 11\xi = F5$$

$$F3 + 5\xi = F5$$

$$F5 = (593.4 + 5 \times 30) \text{ mol/hr}$$

$$F5 = 743.4 \text{ mol/hr}$$

Composition of F5:

$$F3, \omega_{\text{C}_2\text{H}_5\text{OH}} - 3\xi = F5, \omega_{\text{C}_2\text{H}_5\text{OH}}$$

$$(106 - 3 \times 30) \text{ mol/hr} = F5, \omega_{\text{C}_2\text{H}_5\text{OH}}$$

$$F5, \omega_{\text{C}_2\text{H}_5\text{OH}} = 16 \text{ mol/hr}$$

$$F3, \omega_{\text{H}_2\text{SO}_4} - 8\xi = F5, \omega_{\text{H}_2\text{SO}_4}$$

$$(414 - 8 \times 30) \text{ mol/hr} = F5, \omega_{\text{H}_2\text{SO}_4}$$

$$F5, \omega_{\text{H}_2\text{SO}_4} = 174 \text{ mol/hr}$$

$$F3, \omega_{\text{Na}_2\text{Cr}_2\text{O}_7} - 2\xi = F5, \omega_{\text{Na}_2\text{Cr}_2\text{O}_7}$$

$$(73.4 - 2 \times 30) \text{ mol/hr} = F5, \omega_{\text{Na}_2\text{Cr}_2\text{O}_7}$$

$$F5, \omega_{\text{Na}_2\text{Cr}_2\text{O}_7} = 13.4 \text{ mol/hr}$$

$$F5, \omega_{\text{CH}_3\text{COOH}} = 3\xi = 3 \times 30$$

$$F5, \omega_{\text{CH}_3\text{COOH}} = 90 \text{ mol/hr}$$

$$F5, \omega_{\text{Cr}_2(\text{SO}_4)_3} = 2\xi = 2 \times 30$$

$$F5, \omega_{\text{Cr}_2(\text{SO}_4)_3} = 60 \text{ mol/hr}$$

$$F5, \omega_{\text{Na}_2\text{SO}_4} = 2\xi = 2 \times 30$$

$$F5, \omega_{\text{Na}_2\text{SO}_4} = 60 \text{ mol/hr}$$

$$F5, \omega_{\text{H}_2\text{O}} = 11\xi = 11 \times 30$$

$$F5, \omega_{\text{H}_2\text{O}} = 330 \text{ mol/hr}$$

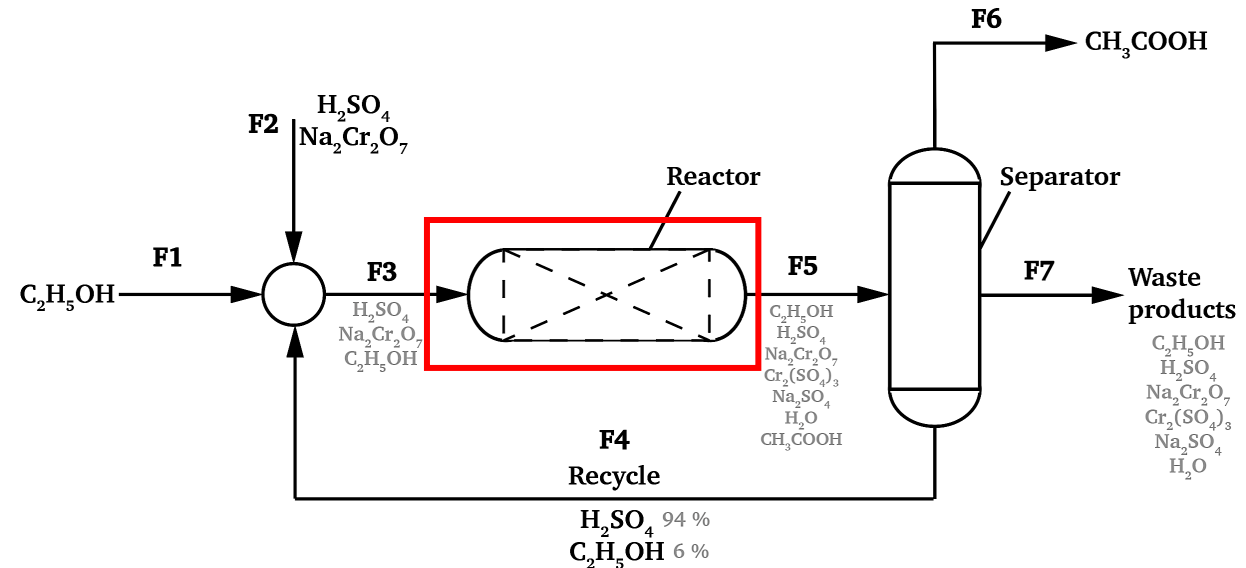

Problem 2: Mass Balance, Reactive Systems (35 points)

c) Compute the flow rate of each stream, as well as the composition of each stream, and fill in the table (15 points).

Composition percentages:

$$F1 = 100 \text{ mol/hr} : \%100 \text{ C}_2\text{H}_5\text{COOH}$$

$$F2 = 393.4 \text{ mol/hr}$$

$$F2, x_{\text{C}_2\text{H}_5\text{OH}} = \frac{320 \text{ mol/hr}}{393.4 \text{ mol/hr}}$$

$$F2, x_{\text{C}_2\text{H}_5\text{OH}} = 0.815$$

Since we have only two compounds in F2, the rest should be $\text{Na}_2\text{Cr}_2\text{O}_7$, thus;

$$F2, x_{\text{Na}_2\text{Cr}_2\text{O}_7} = 0.185$$

$$F3 = 593.4 \text{ mol/hr}$$

$$F3, x_{\text{Na}_2\text{Cr}_2\text{O}_7} = \frac{73.4 \text{ mol/hr}}{593.4 \text{ mol/hr}}$$

$$F3, x_{\text{C}_2\text{H}_5\text{OH}} = \frac{106 \text{ mol/hr}}{593.4 \text{ mol/hr}}$$

$$F3, x_{\text{Na}_2\text{Cr}_2\text{O}_7} = 0.123$$

$$F3, x_{\text{C}_2\text{H}_5\text{OH}} = 0.179$$

$$F3, x_{\text{H}_2\text{SO}_4} = \frac{414 \text{ mol/hr}}{593.4 \text{ mol/hr}}$$

$$F3, x_{\text{H}_2\text{SO}_4} = 0.698$$

$$F4 = 100 \text{ mol/hr}$$

$$F4, x_{\text{C}_2\text{H}_5\text{OH}} = \frac{6 \text{ mol/hr}}{100 \text{ mol/hr}}$$

$$F4, x_{\text{C}_2\text{H}_5\text{OH}} = 0.060$$

$$F4, x_{\text{H}_2\text{SO}_4} = \frac{94 \text{ mol/hr}}{100 \text{ mol/hr}}$$

$$F4, x_{\text{H}_2\text{SO}_4} = 0.940$$

$$F5 = 743.4 \text{ mol/hr}$$

$$F5, x_{\text{C}_2\text{H}_5\text{OH}} = \frac{16 \text{ mol/hr}}{743.4 \text{ mol/hr}}$$

$$F5, x_{\text{C}_2\text{H}_5\text{OH}} = 0.0215$$

$$F5, x_{\text{H}_2\text{SO}_4} = \frac{174 \text{ mol/hr}}{743.4 \text{ mol/hr}}$$

$$F5, x_{\text{H}_2\text{SO}_4} = 0.2341$$

$$F5, x_{\text{Na}_2\text{Cr}_2\text{O}_7} = \frac{13.4 \text{ mol/hr}}{743.4 \text{ mol/hr}}$$

$$F5, x_{\text{Na}_2\text{Cr}_2\text{O}_7} = 0.0180$$

$$F6 = 90 \text{ mol/hr}$$

Since this stream consists of pure CH_3COOH , it is 100% for CH_3COOH .

$$F5, x_{\text{Cr}_2(\text{SO}_4)_3} = \frac{60 \text{ mol/hr}}{743.4 \text{ mol/hr}}$$

$$F5, x_{\text{Cr}_2(\text{SO}_4)_3} = 0.0807$$

$$F5, x_{\text{Na}_2\text{SO}_4} = \frac{60 \text{ mol/hr}}{743.4 \text{ mol/hr}}$$

$$F5, x_{\text{Na}_2\text{SO}_4} = 0.0807$$

$$F5, x_{\text{H}_2\text{O}} = \frac{330 \text{ mol/hr}}{743.4 \text{ mol/hr}}$$

$$F5, x_{\text{H}_2\text{O}} = 0.4439$$

$$F5, x_{\text{CH}_3\text{COOH}} = \frac{90 \text{ mol/hr}}{743.4 \text{ mol/hr}}$$

$$F5, x_{\text{CH}_3\text{COOH}} = 0.1211$$

$$F7 = 553.4 \text{ mol/hr}$$

$$F7, x_{\text{C}_2\text{H}_5\text{OH}} = \frac{10 \text{ mol/hr}}{553.4 \text{ mol/hr}}$$

$$F7, x_{\text{C}_2\text{H}_5\text{OH}} = 0.0181$$

$$F7, x_{\text{H}_2\text{SO}_4} = \frac{80 \text{ mol/hr}}{553.4 \text{ mol/hr}}$$

$$F7, x_{\text{H}_2\text{SO}_4} = 0.1445$$

$$F7, x_{\text{Na}_2\text{Cr}_2\text{O}_7} = \frac{13.4 \text{ mol/hr}}{553.4 \text{ mol/hr}}$$

$$F7, x_{\text{Na}_2\text{Cr}_2\text{O}_7} = 0.0242$$

$$F7, \omega_{\text{Cr}_2(\text{SO}_4)_3} = \frac{60 \text{ mol/hr}}{553.4 \text{ mol/hr}}$$

$$F7, \omega_{\text{Cr}_2(\text{SO}_4)_3} = 0.1084$$

$$F7, \omega_{\text{Na}_2\text{SO}_4} = \frac{60 \text{ mol/hr}}{553.4 \text{ mol/hr}}$$

$$F7, \omega_{\text{Na}_2\text{SO}_4} = 0.1084$$

$$F7, \omega_{\text{H}_2\text{O}} = \frac{330 \text{ mol/hr}}{553.4 \text{ mol/hr}}$$

$$F7, \omega_{\text{H}_2\text{O}} = 0.5963$$

Problem 2: Mass Balance, Reactive Systems (35 points)

c) Compute the flow rate of each stream, as well as the composition of each stream, and fill in the table (15 points).

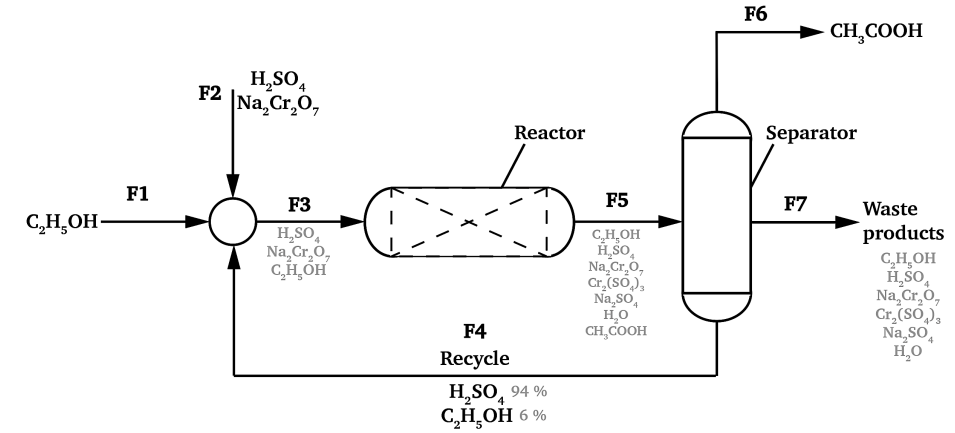

	F1	F2	F3	F4	F5	F6	F7
Flow rate (mol/h)	100	393.4	593.4	100	743.4	90	553.4
$x_{C_2H_5OH}$	1	0	0.1790	0.0600	0.0215	0	0.0181
$x_{H_2SO_4}$	0	0.8150	0.6980	0.9400	0.2341	0	0.1445
$x_{Na_2Cr_2O_7}$	0	0.1850	0.1230	0	0.0180	0	0.0242
x_{CH_3COOH}	0	0	0	0	0.1211	1	0
$x_{Cr_2(SO_4)_3}$	0	0	0	0	0.0807	0	0.1084
$x_{Na_2SO_4}$	0	0	0	0	0.0807	0	0.1084
x_{H_2O}	0	0	0	0	0.4439	0	0.5963

Problem 2: Mass Balance, Reactive Systems (35 points)

d) Calculate the conversion of C_2H_5OH in the reactor (7 points).

Conversion of C_2H_5OH :

$$conv_{C_2H_5OH} = \frac{F3, x_{C_2H_5OH} - F5, x_{C_2H_5OH}}{F3, x_{C_2H_5OH}}$$

Consumed Ethanol

Fed Ethanol

$$conv_{C_2H_5OH} = \frac{(593.3 \text{ mol/hr} * 0.179) - (743.3 \text{ mol/hr} * 0.02)}{593.3 \text{ mol/hr} * 0.179}$$

$$conv_{C_2H_5OH} = \frac{106 - 16}{106}$$

$$conv_{C_2H_5OH} = 0.85 = 85 \%$$

