

Problem 1: Mass Balance, Non-reactive

A plating plant has a waste stream, F, containing zinc and nickel in quantities exceeding the legal allowed to be discharged into the sewer (Stream D). The proposed process for reducing the concentration of Zn and Ni is shown in the figure below. Each stream contains water and the concentration of the elements (Zn and Ni) in several of the streams are listed in the table. Determine the flow rates (in L/hr) of the streams mentioned in the second table below if the feed F is 1 L/hr.

Stream	Zn (g/L)	Ni (g/L)
F	100	10.0
P ₀	190.1	17.02
P ₂	3.50	2.19
R ₃₂	4.35	2.36
W	0	0
D	0.10	1.00

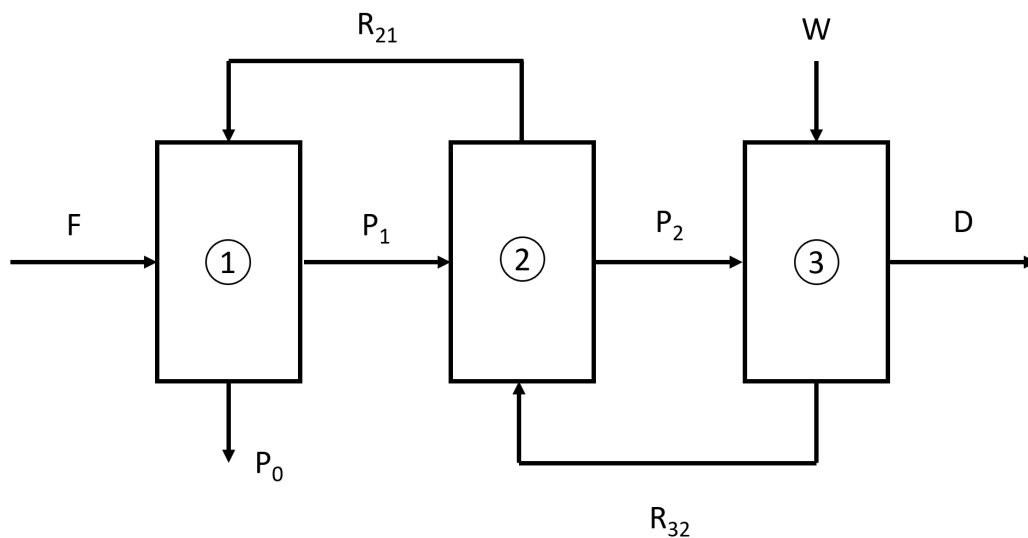

Stream	Flow rate (L/hr)
F	1
P ₀	
P ₂	
R ₃₂	
D	

Hint: Not all streams in the flowchart can be calculated by the info above.