

Multiple Choice Questions

1) ES cells are modified by adding lox sites as well as a Neo (neomycin resistance) cassette (step 1 on the figure). After homologous recombination, the lox sites and Neo cassette are inserted on the genome. How many possible products might you get from the expression of the Cre recombinase in those modified ES cells?

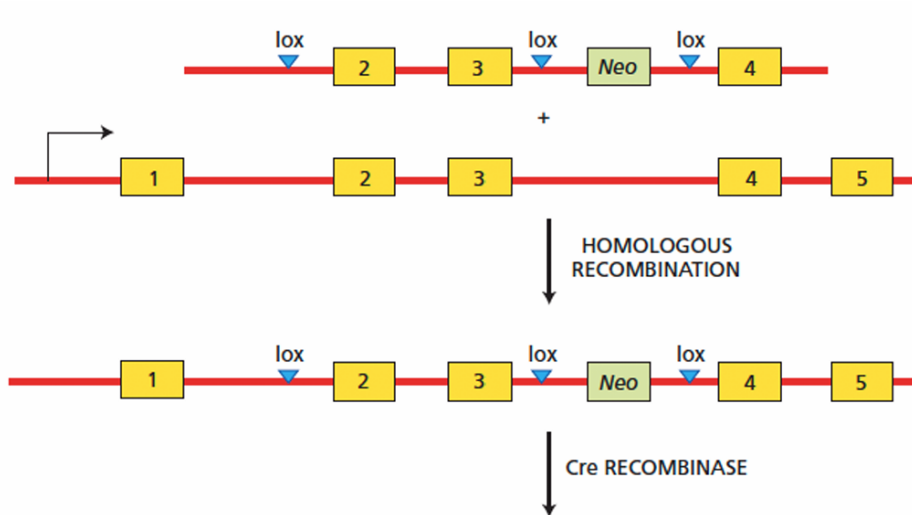

- a) One knock-out product (genetic modification where a gene is completely inactivated or removed).
- b) Five different products.
- c) Two knock-out products and one knock-in (genetic modification where a specific DNA sequence is inserted into a precise location in the genome).
- d) Three products: one knock-out, one knock-in, and one wild type (the original sequence).
- e) Four different products.

The correct answers in D. The three possible products of Cre-mediated site-specific recombination are shown in the figure below.

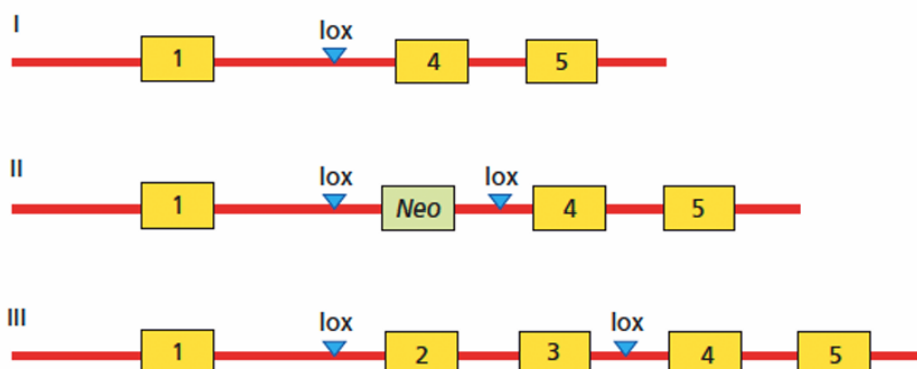

2) You need to generate a knock-in animal to study the function of a mutated gene in the liver. Which method is the least efficient for you to obtain the knock-in animal?

- a) Genome editing by CRISPR-Cas9.
- b) Pro-nuclear injection.
- c) Manipulation of ESC (Embryonic Stem Cells).
- d) Nuclear transfer.
- e) All.

The correct answer is A. Usually, CRISPR/CAS9 is a method used to repair or introduce mutations in endogenous genes, not to insert a new copy of the gene into the organism.

3) What is the role of sticky ends in the DNA cloning process, and why must they be compatible?

- a) Sticky ends enable complementary base pairing between DNA fragments.
- b) Compatible sticky ends increase the efficiency of DNA ligase activity.
- c) Non-compatible sticky ends can still anneal but with lower stability.
- d) Sticky ends are only required for the plasmid, not for the DNA insert.

Correct answers are A and B. Sticky ends allow DNA fragments to anneal through base pairing, and compatibility ensures efficient and stable ligation by DNA ligase. Non-compatible ends cannot pair correctly, and both plasmid and insert DNA must have compatible ends.

4) Which of the following techniques are used to study gene expression, and what specific information do they provide?

- a) Northern blotting: Detects and quantifies RNA levels in a sample.
- b) RNA-seq: Provides a global view of all RNAs being transcribed, including their abundance.
- c) Microarrays: Detect changes in gene expression using hybridization with known sequences.
- d) RT-PCR: Measures DNA levels directly to infer gene expression.

Correct answers are A, B and C. Northern blotting detects specific RNAs and can estimate their abundance. RNA-seq is a comprehensive method for quantifying and identifying all RNA transcripts. Microarrays detect gene expression patterns but require prior knowledge of the sequences. RT-PCR measures RNA levels (not DNA) after reverse transcription into complementary DNA (cDNA).

5) Which genetic test needs to be used to compare the phenotypes of different combinations of mutations to determine the order in which the genes act?

- a) qRT-PCR.
- b) Conditional mutation test.
- c) Sequencing different genes.
- d) Epistasis analysis.
- e) Combinatorial test (experimental used to study the interactions or combined effects of multiple genetic or molecular elements simultaneously).

The correct answer is D. The epistasis analyses can reveal the order of action of two genes that act in a linear pathway through the analysis of double mutants.

6) What is correct concerning FRET?

- a) The excitation wavelength of the fluorescent protein that is excited by a light source must match the excitation spectrum of the second fluorescent protein.
- b) The emission wavelength of the fluorescent protein that is excited by a light source must match the emission spectrum of the second fluorescent protein.
- c) The excitation wavelength of the fluorescent protein that is excited by a light source must match the emission spectrum of the second fluorescent protein.
- d) The emission wavelength of the fluorescent protein that is excited by a light source must match the excitation spectrum of the second fluorescent protein.
- e) The emission wavelength of the fluorescent protein that is excited by a light source must be larger than the emission spectrum of the second fluorescent protein.

The correct answer is D. Since the light source will excite a first fluorescent protein, which will then emit light – this light will then excite the second fluorescent protein. Thus, the light emitted by the first fluorescent protein must match the excitation spectrum of the second fluorescent protein, which will emit in larger wavelengths than the first fluorescent protein.

True or False:

1) Western blotting can allow identifying two proteins resulting from splice variants of the same gene.

True, as long as the site of the protein that is recognized by the antibody is present on both splice variants.

2) Loss-of-function mutations are usually recessive.

True, mutations that eliminate the function of a protein are usually recessive. In a diploid organism, one copy of the wild-type allele can usually compensate for the loss of function allele.

3) The use of RNA sequencing allows for the detection of RNA splicing, RNA editing, and non-coding RNAs in addition to quantifying mRNA levels.

True, RNA-seq provides a comprehensive method for cataloging RNAs, including detecting alternative splicing and editing events.

4) Eukaryotic genes are always expressed properly in bacteria, as bacteria have all the necessary machinery for post-translational modifications.

False, eukaryotic genes often do not express correctly in bacteria due to the absence of necessary post-translational modification machinery, so eukaryotic cells are typically used.

5) Microarrays require that the sequences of mRNA samples to be analyzed are already known and represented by corresponding probes on the array.

True, microarrays use pre-designed probes, which means the mRNA sequences to be analyzed need to be known in advance.