

Practical Sessions

Every Tuesdays 11.00-13.00

- Projects
- Exercise

Francesca



francesca.rodino@epfl.ch

- PhD student at Bio/CMOS Interfaces Laboratory
- Education: Biomedical Engineering (B.Sc. and M.Sc.)
- **Ph.D. project:** Developing electrochemical biosensors and front-end electronics for therapeutic monitoring of multiple chemotherapeutic drugs for personalized medicine.

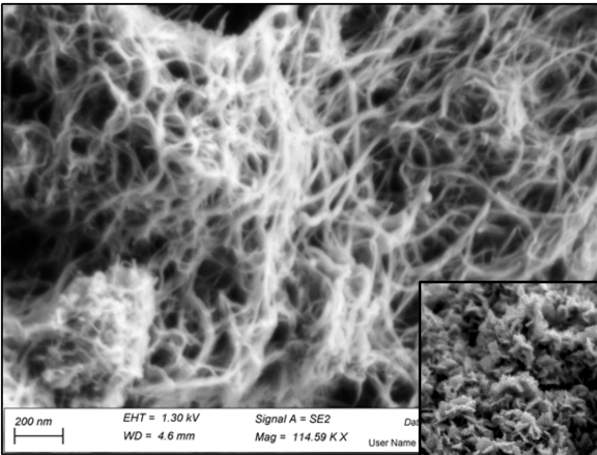

Carbon nanotubes (CNTs)

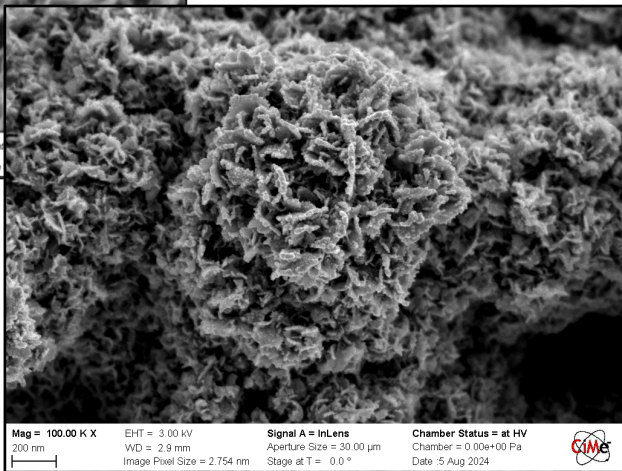

Nano Pt structures



Specific functionalization (i.e., enzymes)

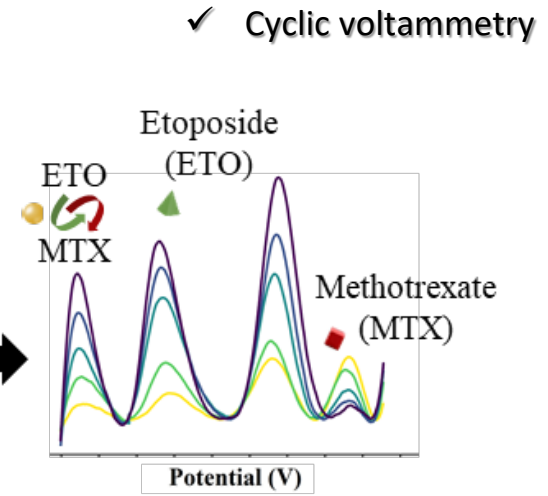

Electronic Design

↑ Sensitivity

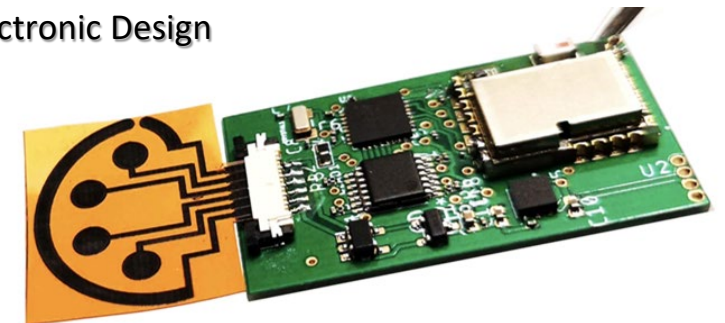
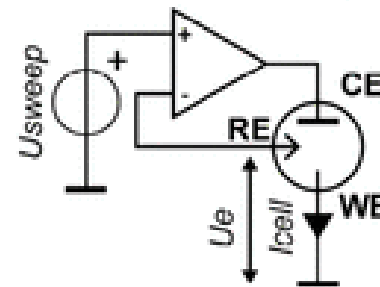

Francesca



francesca.rodino@epfl.ch

- PhD student at Bio/CMOS Interfaces Laboratory
- Education: Biomedical Engineering (B.Sc. and M.Sc.)
- **Ph.D. project:** Developing electrochemical biosensors and front-end electronics for therapeutic monitoring of multiple chemotherapeutic drugs for personalized medicine.

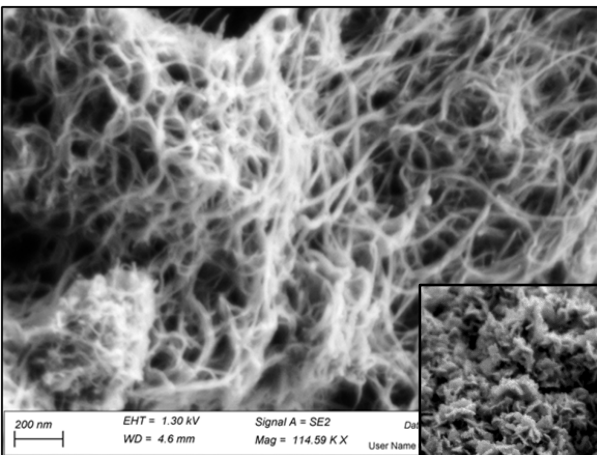

Carbon nanotubes (CNTs)

Specific functionalization
Nano Pt structures

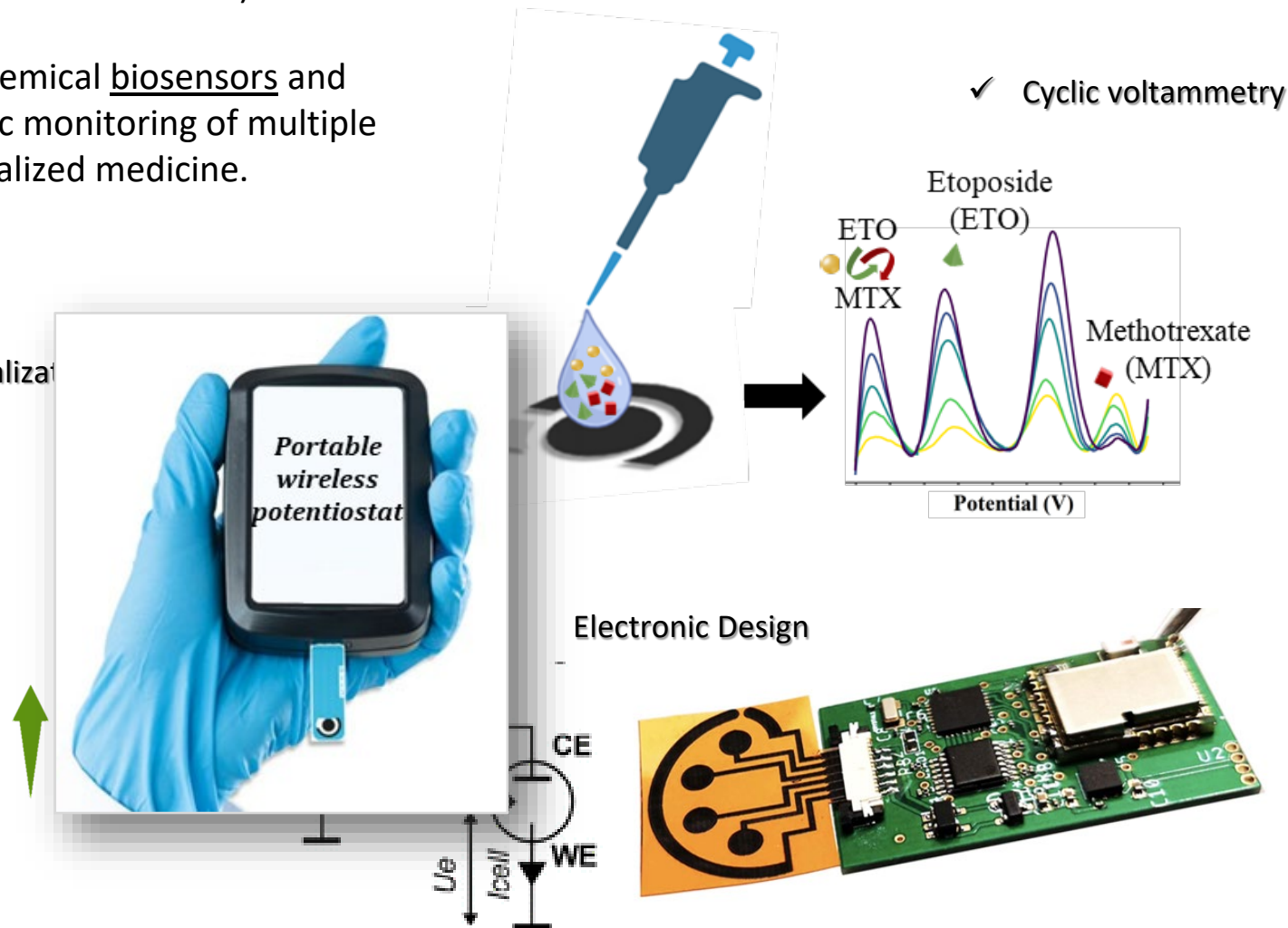
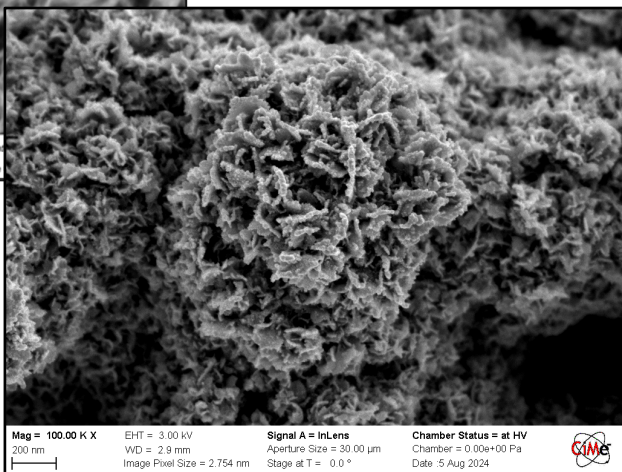

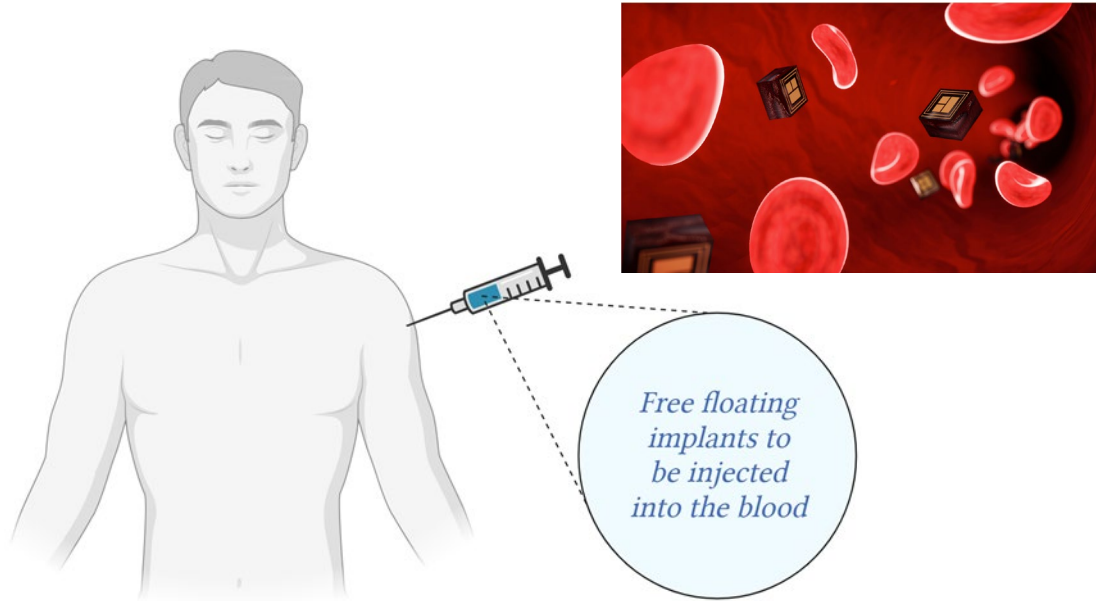

Free floating implants to be injected into the blood

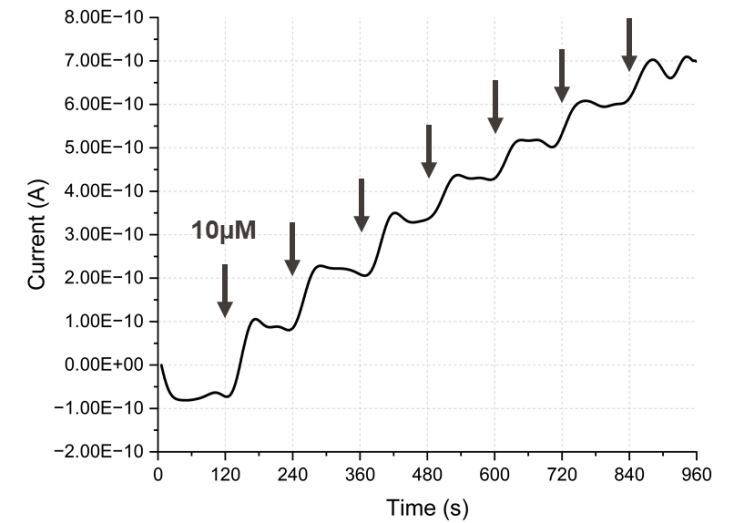
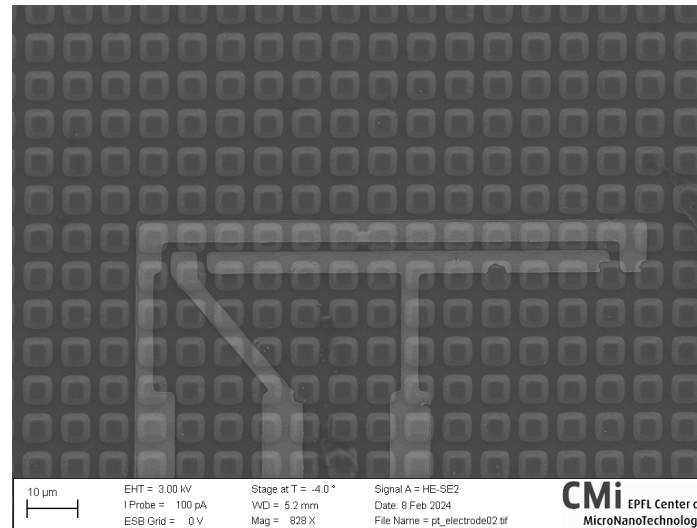
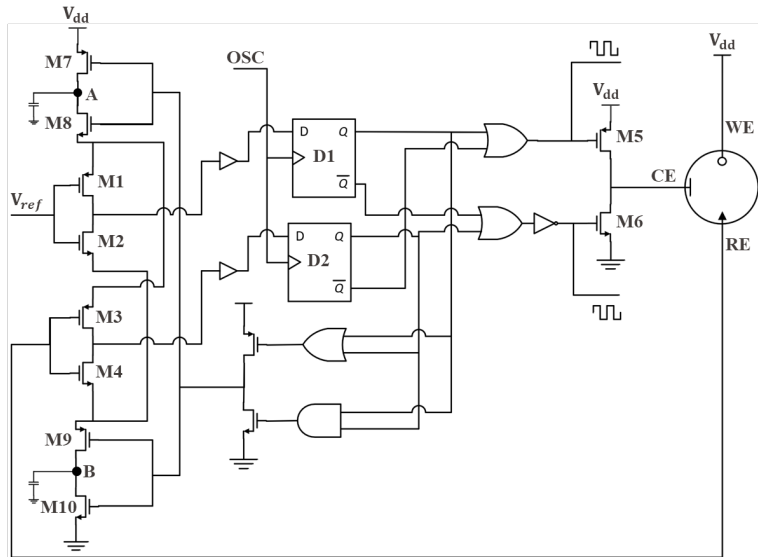
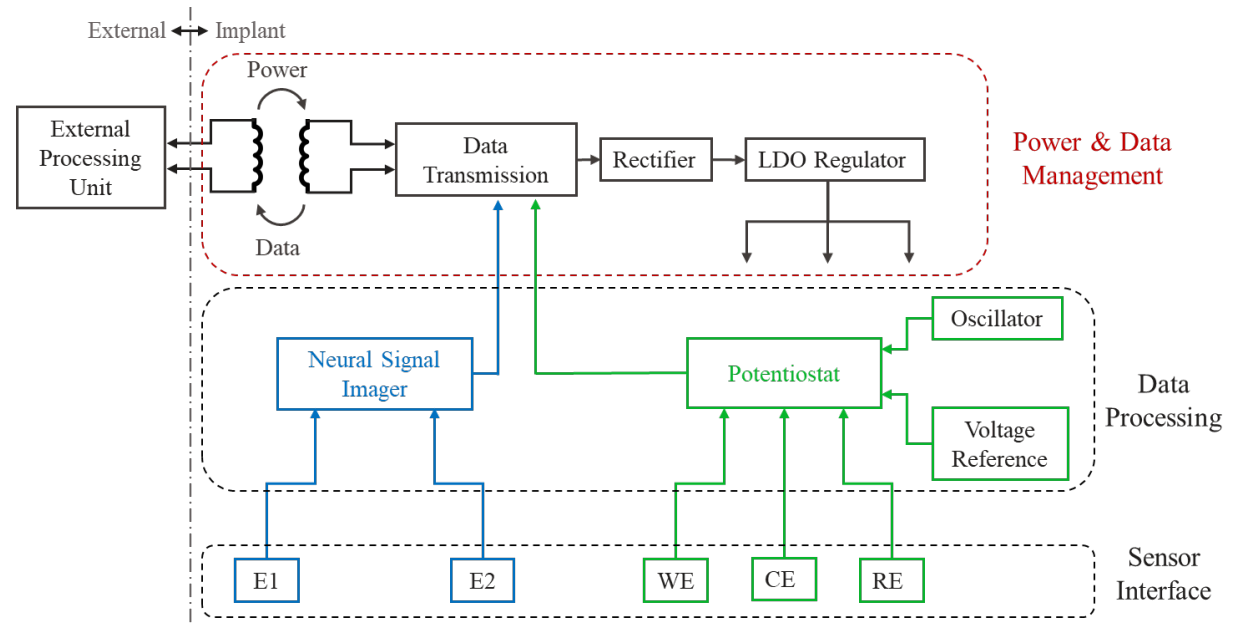

Gian Luca

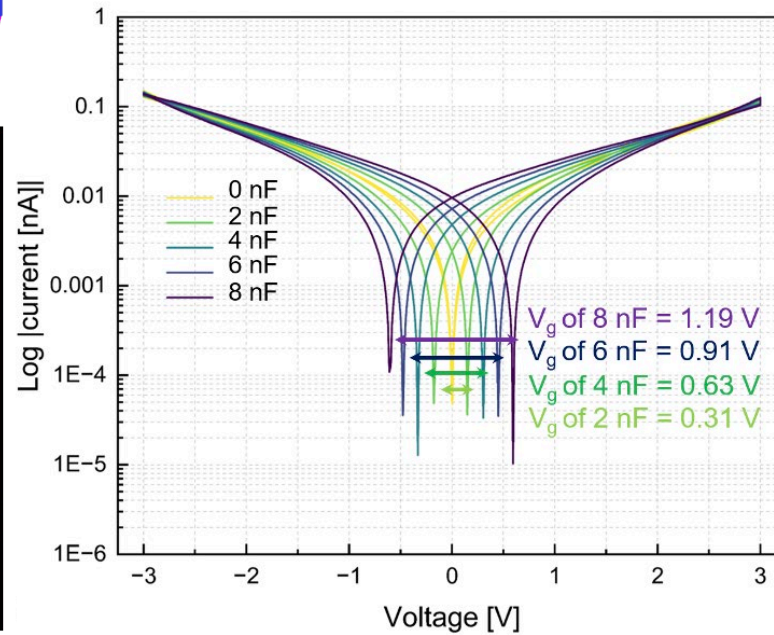
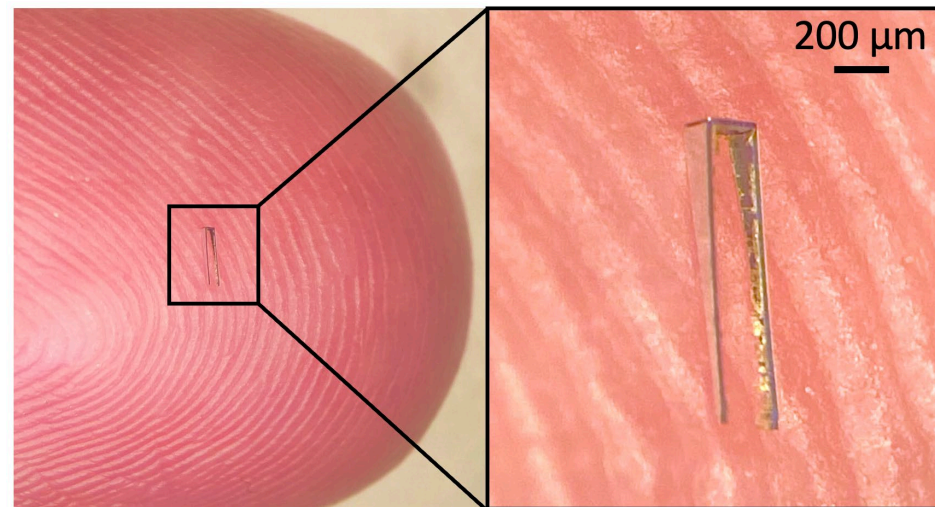
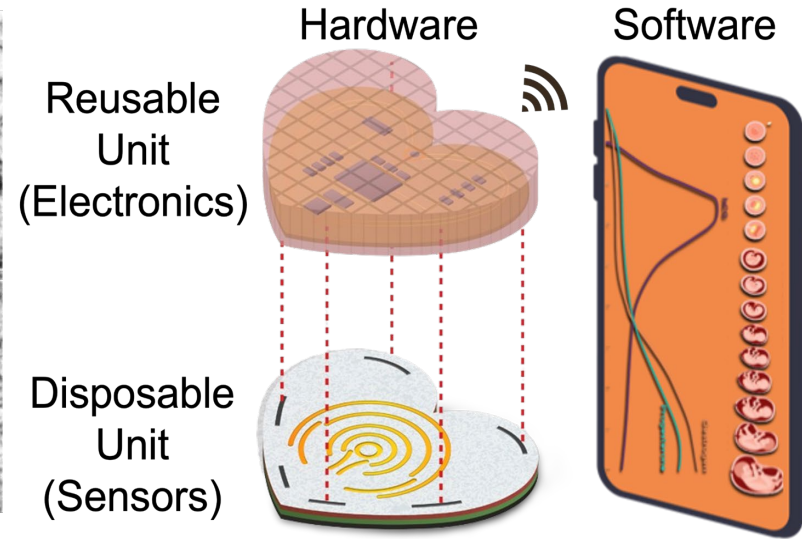
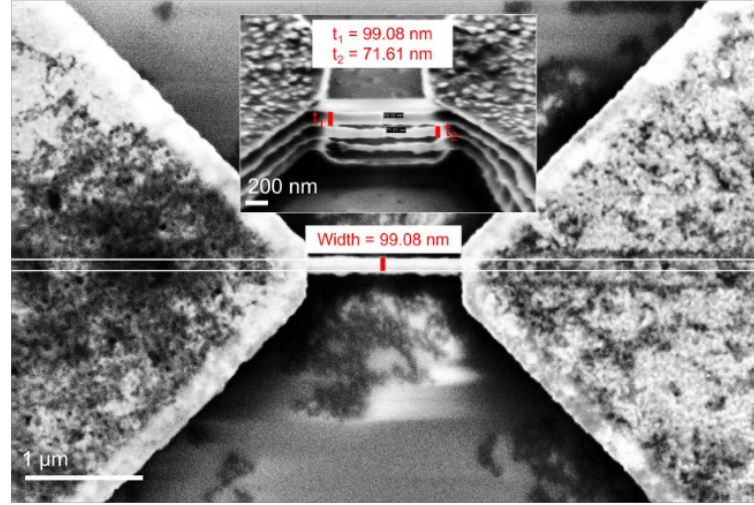
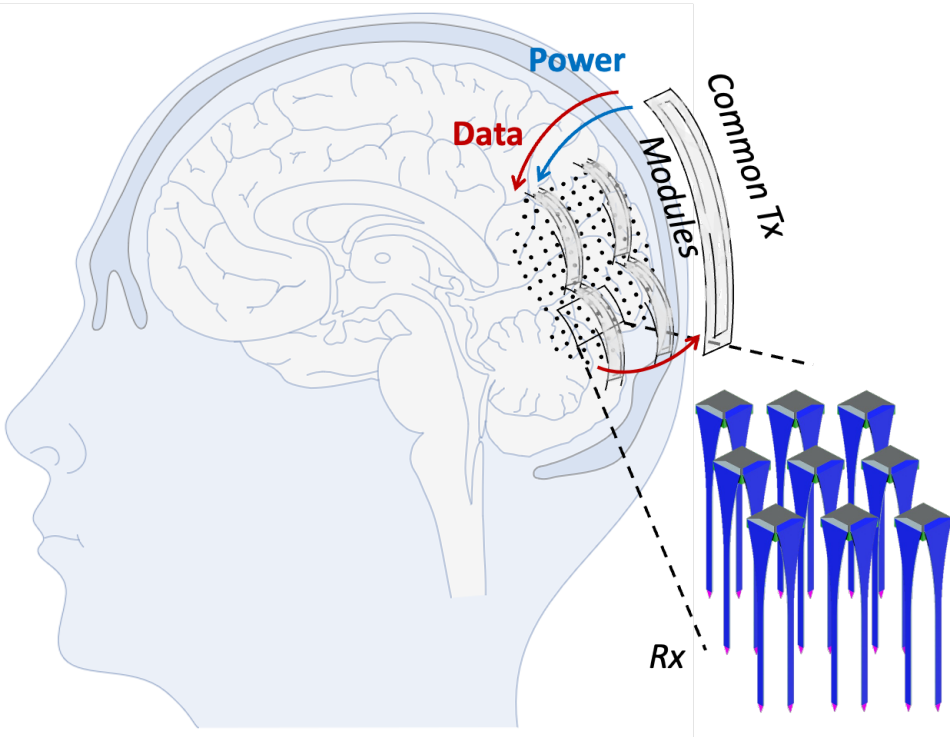

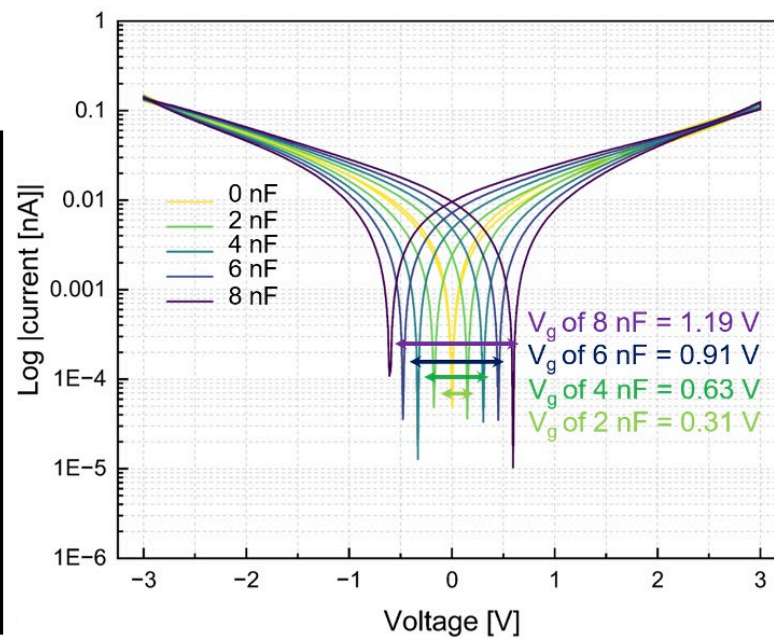
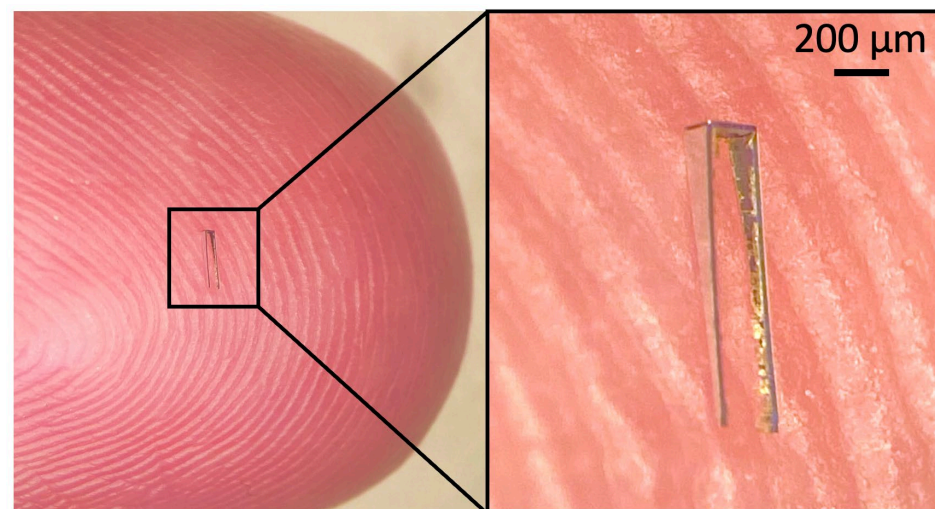
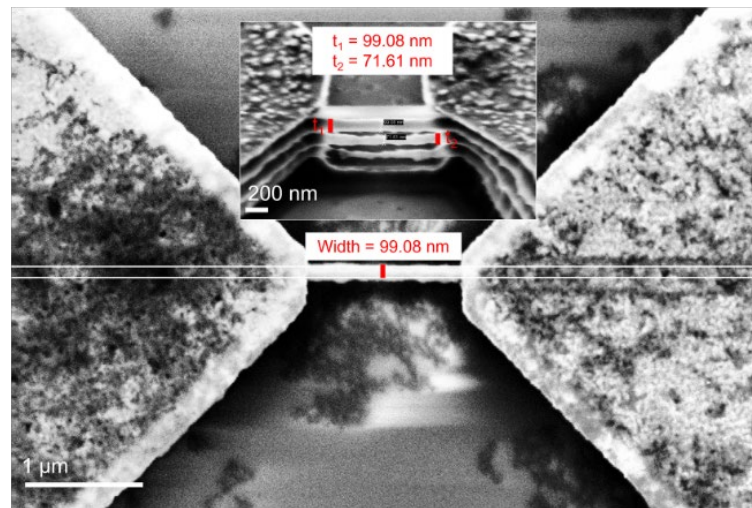
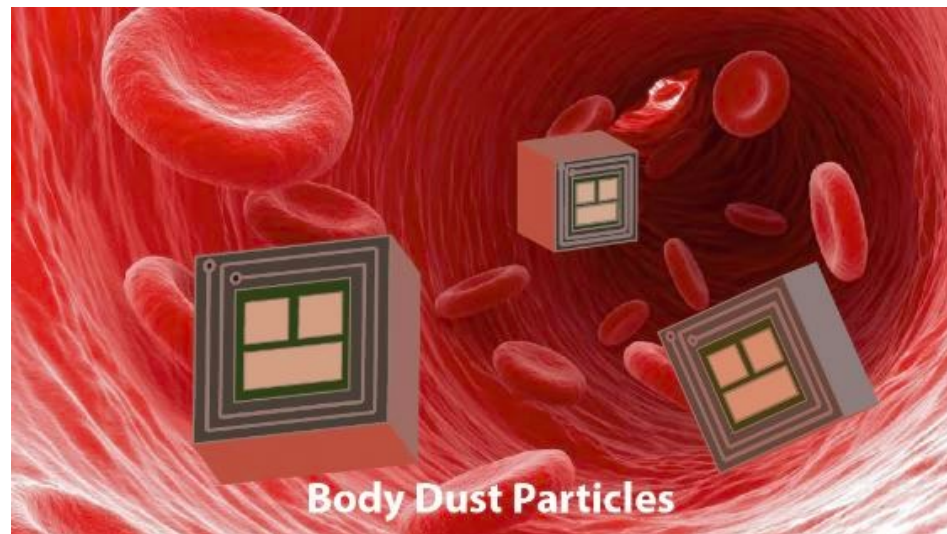

Kolb experimental learning cycle

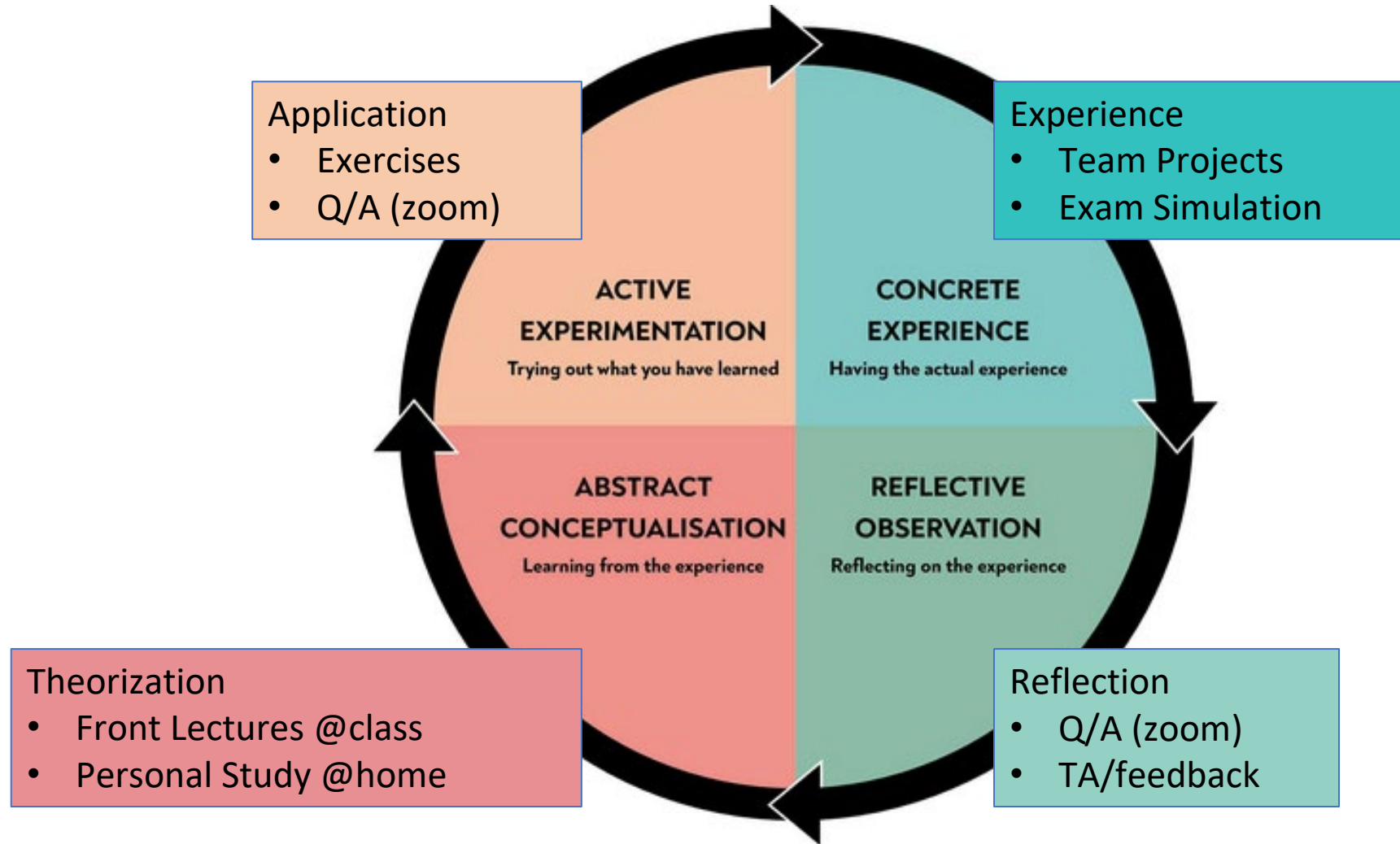

1. The project is **mandatory**.
2. The Project counts for 60 points maximum on the final grade.
3. The Written exam also counts for 60 point maximum on the final grade.
4. **Obtaining 40 points out of 60 in the written exam is mandatory for the project to be counted.**
5. **The Final Grade** is obtained by adding all the gained points on 120 points maximum, and then reporting the final grade on 6 maxima.

Project Rules

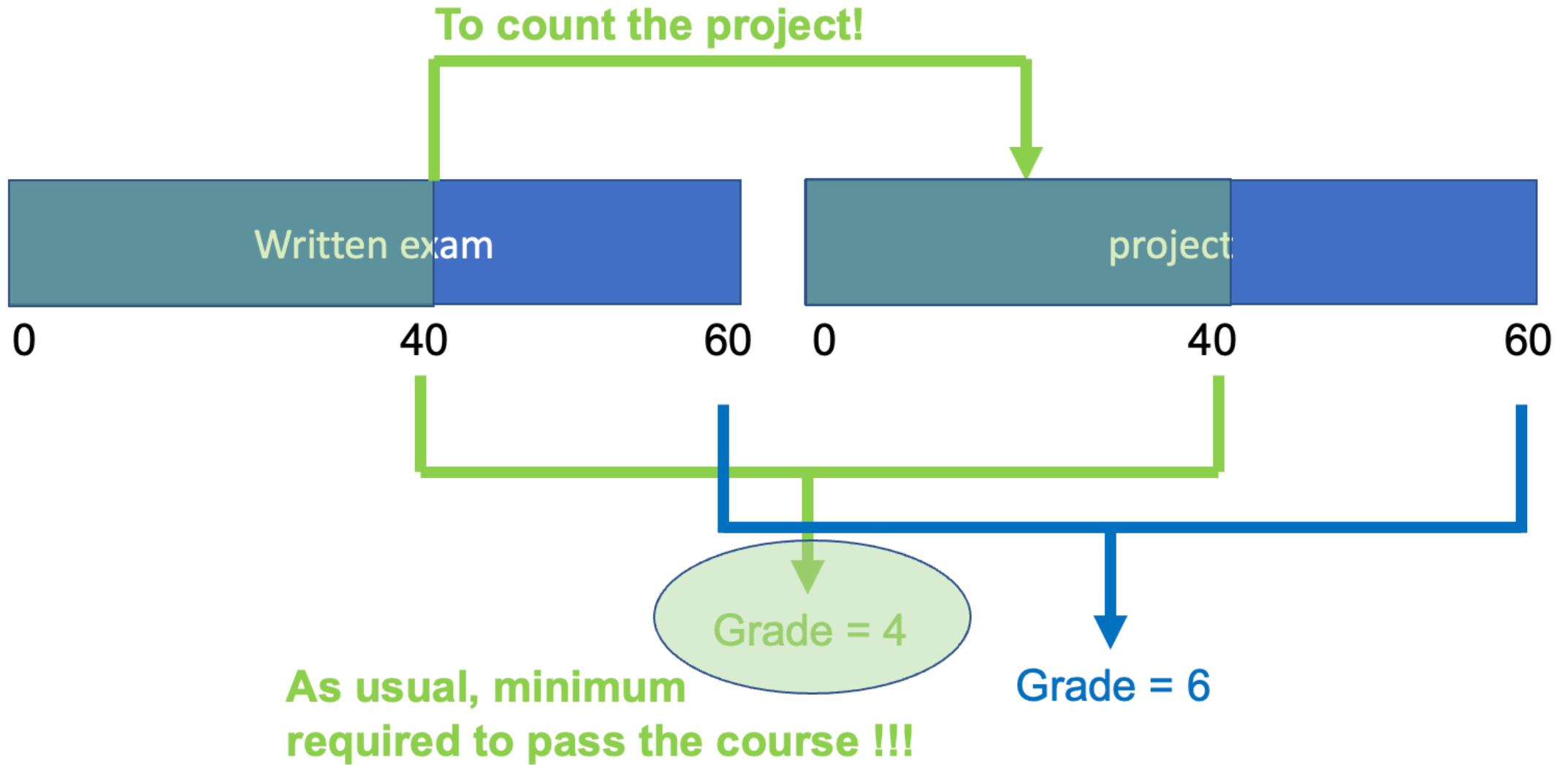

Project Rules

6. Students are **individually required to propose a project** (following the project template form) **within week 2 - Friday, 17.00**. Proposals must be sent to all TAs by email in pdf format (object: “EE-517 Project”, filename: <EE-517_proposal_name_surname>)
7. The TAs will evaluate all the individual proposals based on the overall quality, final scope and timeline feasibility. The TAs will attribute final projects and working groups before week 3.
8. Every week, during the project session, the TAs will supervise the groups in their own project.
9. **Groups are required to submit one progressive report** following the guidelines and the template given by the TAs to receive their feedback and comments about the progress of their work. Progressive report must be sent to all TAs **within week 9 - Friday, 17.00** by email in .pdf format (object: “EE-517 Project”, filename: <EE-517_group#XX_Progressive>)
10. **A final report** (following the IEEE template provided) **will be required from each group within 31st of December**. The final report must be sent to all TAs by email in .pdf format (object: “EE-517 Project”, filename: <EE-517_group#XX_final>)
11. The TAs will evaluate the reports assigning the final mark, based on the technical quality, completeness, and clarity.
12. In order to obtain the maximum grade, the project needs to be focused on electrochemical detection only and needs to include at least the three aspects covered by the course: Bio, Nano, and CMOS.
13. The **Project evaluation** is done based on the following aspects:
 - a. **Individual proposal: 15 points (individual mark)**
 - b. **Progressive report: 15 points (group mark)**
 - c. **Final report: 15 points (group mark)**
 - d. **Individual queries during the sessions: 15 points (individual mark)**
14. **Motivational hint: exceptionally good-projects might have the possibility to be submitted to an internationally-recognized and peer-reviewed scientific conference**. At least, along the years, it happened sometimes! For example, the paper titled “Portable Breathalyzer for Exhaled Volatile Organic Compounds Monitoring in Lung Diseases” by Alec Chevrot, Justina Venckute, and Sarah Cuesta; published in the Proceedings of the IEEE Medical Measurements and Applications (MeMeA), held in 2022.
15. People of reference of project supervision and management:
Francesca Rodino (francesca.rodino@epfl.ch) - Gian Luca Barbruni (gianluca.barbruni@epfl.ch) - Ali Meimandi (ali.meimandi@epfl.ch)

→ **Oral presentation (last class, 17/12)**

Practical Sessions



Francesca Rodino
francesca.rodino@epfl.ch



Gian Luca Barbruni
gianluca.barbruni@epfl.ch



Ali Meimandi
ali.meimandi@epfl.ch

If you are interested in semester/master projects: <https://www.epfl.ch/labs/bci/student-projects>

Weekly schedule

	Objectives of the class	Deliverables	Deadline	TA
Week 1: Introduction to bio-nano-chip design and conductive solutions	<ul style="list-style-type: none"> - Finding a brilliant project idea! - Evaluating the novelty of the idea by literature search 	Individual project proposal	Week 2 - Friday, 17h00	Fra, GL, Ali
Week 2: Probes/Targets Building Blocks	<ul style="list-style-type: none"> - Project proposal writing according to the template 			Francesca
Week 3: Probe/Target interactions	<ul style="list-style-type: none"> - Contact and meet team members as soon as possible - Focus on literature review to identify similar published works - identify biomaterial to sense and from which biofluid and identify required specification 			
Week 4: Probe Detection Principles (Faradaic Processes)	<ul style="list-style-type: none"> - identify the strategy to recognize the chosen target molecule - Identify method (CV, CA, ...) 			
Week 5: Probe Detection Principles (with Antibodies and DNA)	<ul style="list-style-type: none"> - Calculate area/ sensitivity 			
Week 6: Probes immobilisation	<ul style="list-style-type: none"> - Literature analysis - Identify nanomaterials that can be used for increasing sensitivity and creating selectivity 			GL
Week 7: Checking Probes-layer quality (RM+SPR+SEM+AFM)	<ul style="list-style-type: none"> - Identify possible undesired interactions with other molecules and think how to prevent it 			
Week 8: Nanotechnology to prevent Electron Transfer	<ul style="list-style-type: none"> - Identify sensitivity and specificity of the designed bio-nano probe - Calculate/Discuss the improved sensitivity 			
Week 9: Nanotechnology to enhance Electron Transfer	<ul style="list-style-type: none"> - 1 page max group progress report for weeks 1 to 5 (+1 page references) 	Group progressive report	Week 9 - Friday, 17h00	
Week 10: CMOS Building Blocks	<ul style="list-style-type: none"> - Identify the adequate method for electrochemical sensing and design a signal conditioning unit for the proposed electrochemical sensor 			Ali
Week 11: Circuits for metabolites detection in Fixed-Voltage	<ul style="list-style-type: none"> - Communication synthesis; - Unified system-level synthesis of Bio-Nano-CMOS-sensing device 			
Week 12: Circuits for metabolites detection in Scanning Voltage	<ul style="list-style-type: none"> - Simulation of the proposed design using the LTspice software or similar 			
Week 13: CMOS Circuits for DNA Detection	<ul style="list-style-type: none"> - Complete the front-end of the sensor at system level or transistor level by searching the market or designing the CMOS circuit - Presentation preparation 	Group presentation	Week 14 - 11.00-13.00	
Week 14: Review	<ul style="list-style-type: none"> - Groups presentations - Final project report 3 pages (+1 page references) IEEE template	Final group project report	31.12.2024	Fra, GL, Ali

Summary – Deliverables over the semester

1. Individual project proposal

Deadline: week 2 - Friday, 17.00

2. One progressive report

Deadline: week 9 - Friday, 17.00

3. Oral presentation

Tuesday, 17th of December

4. A final report (following the IEEE template provided)

Deadline: 31st of December

- 
- Bio
 - Nano
 - CMOS

Project Proposal



Point-of-care

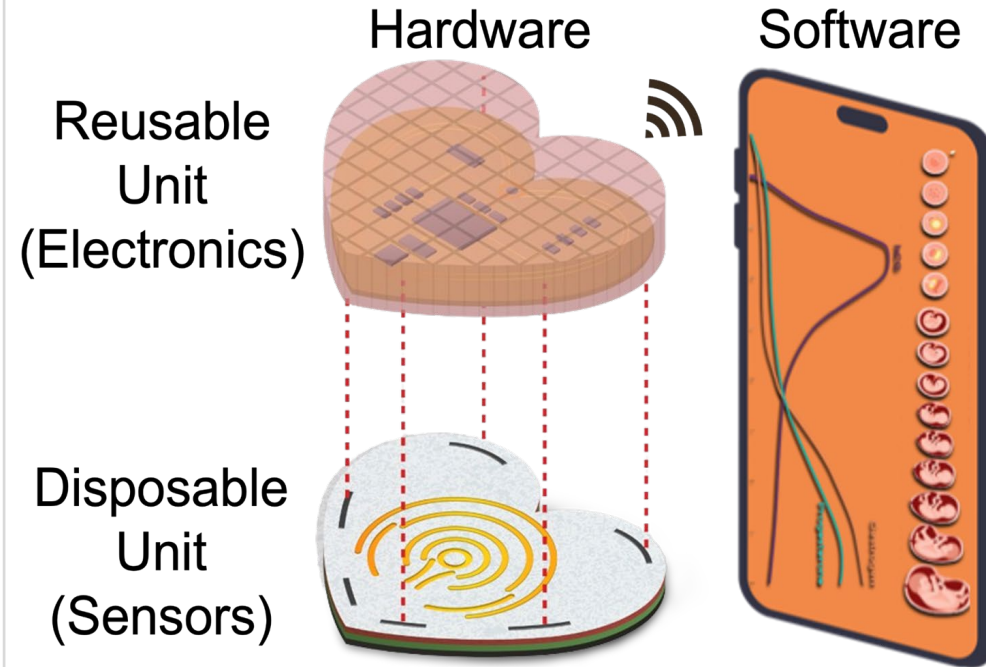

Wearable

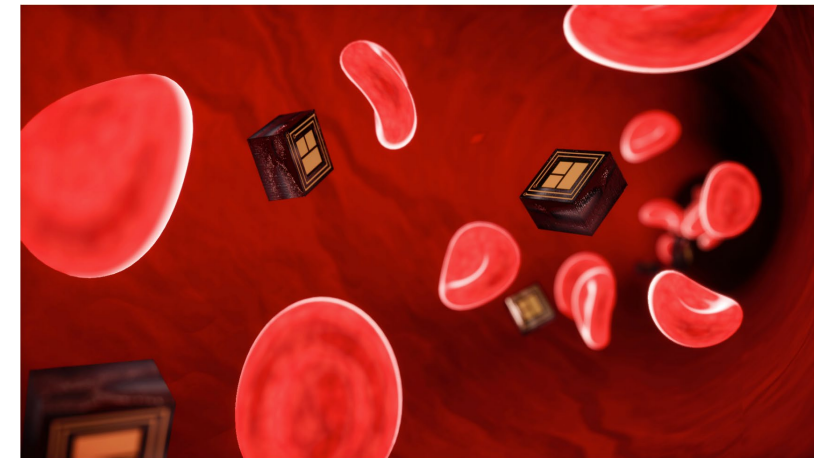

Implantable

Project Proposal

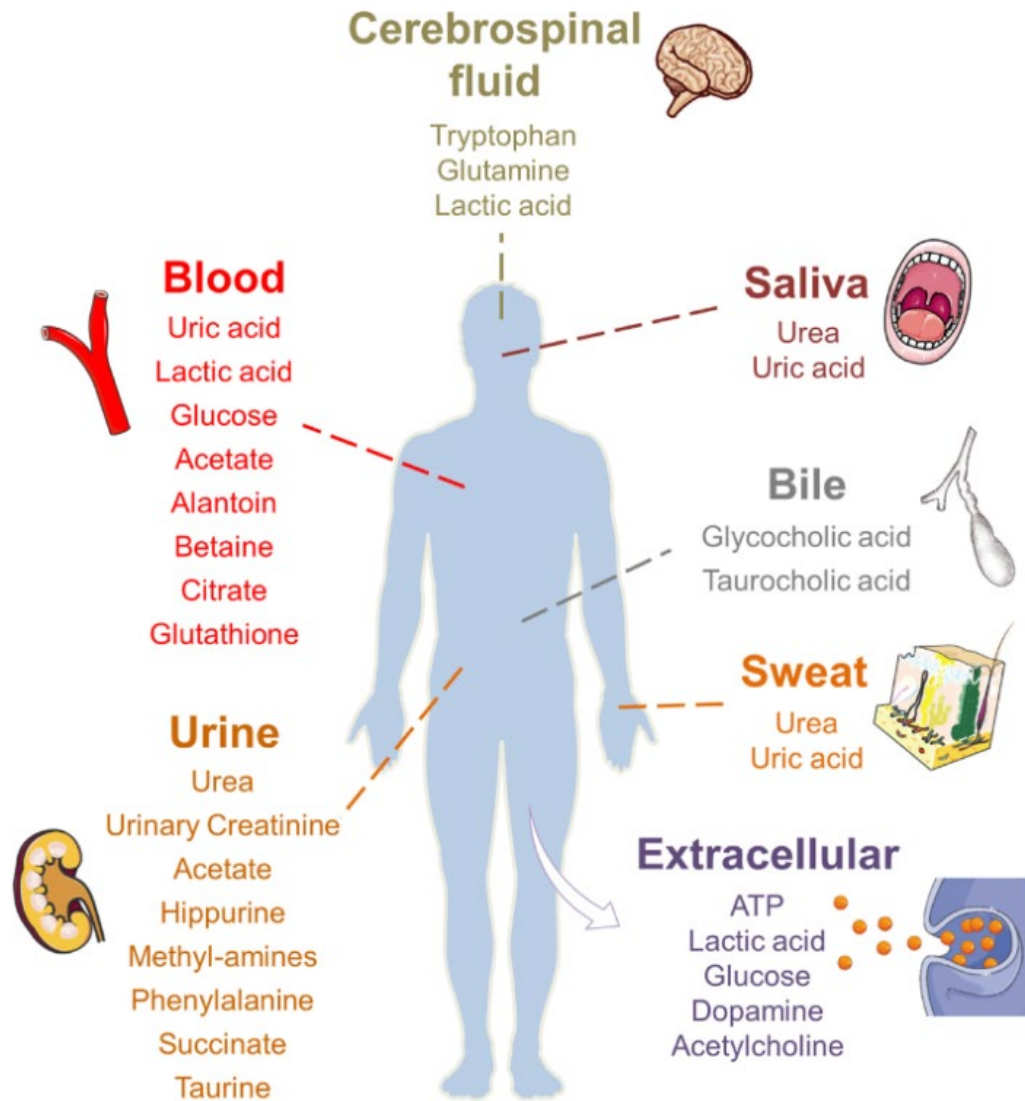

Fig. 1. Common metabolites from biofluids and cells.

Example

Urea:

Blood between 2.5 and 7.1 mmol/l
Sweat between 5 and 50 mmol/l
Saliva between 0.1 and 2 mmol/l
Urine: daily excretion of 342 ± 67 mmol in 490 to 2690 mL

Lu, Y., Lin, L. and Ye, J., 2022. Human metabolite detection by surface-enhanced Raman spectroscopy. *Materials Today Bio*, p.100205.

Project Proposal

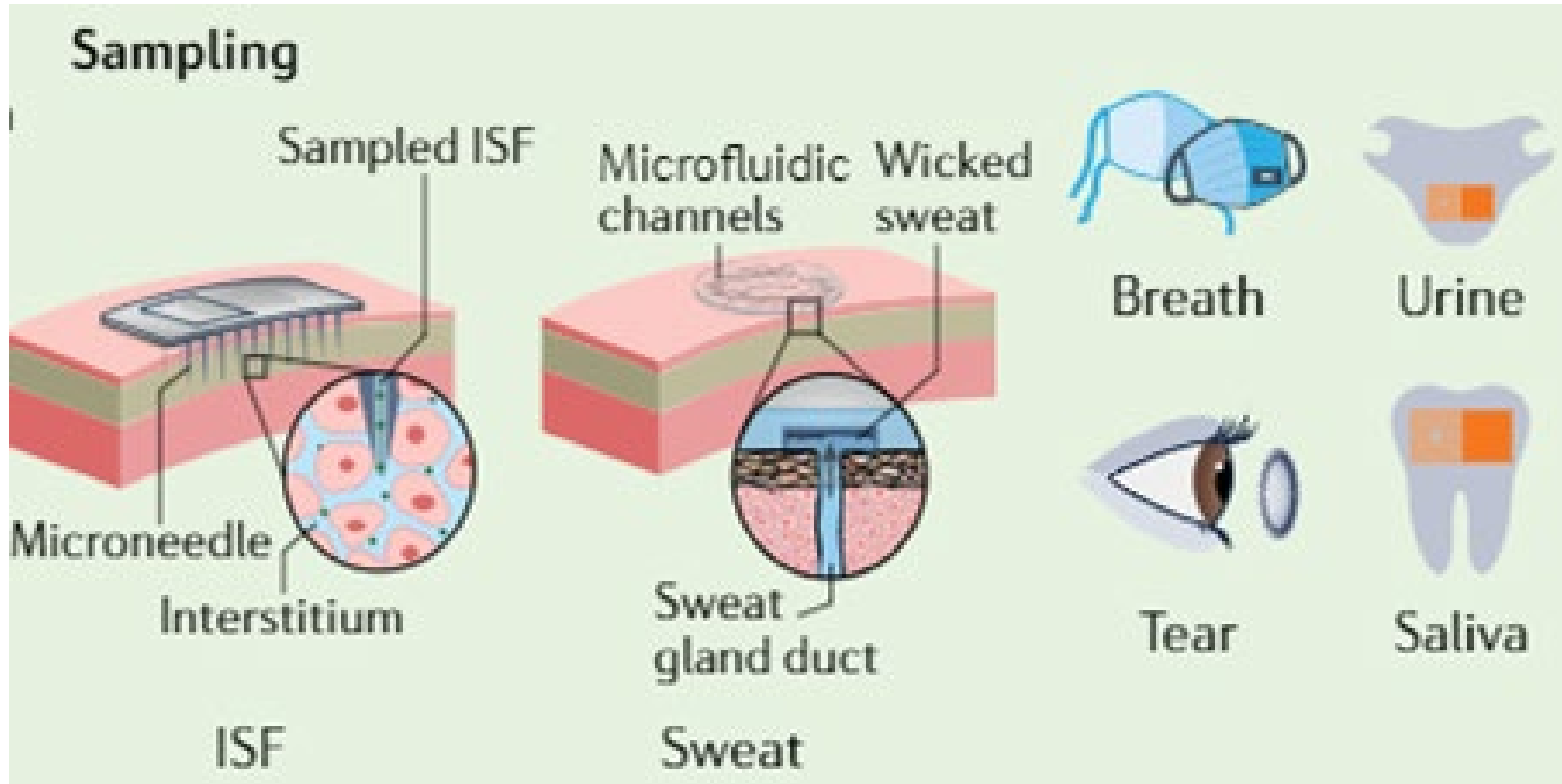

Project Proposal

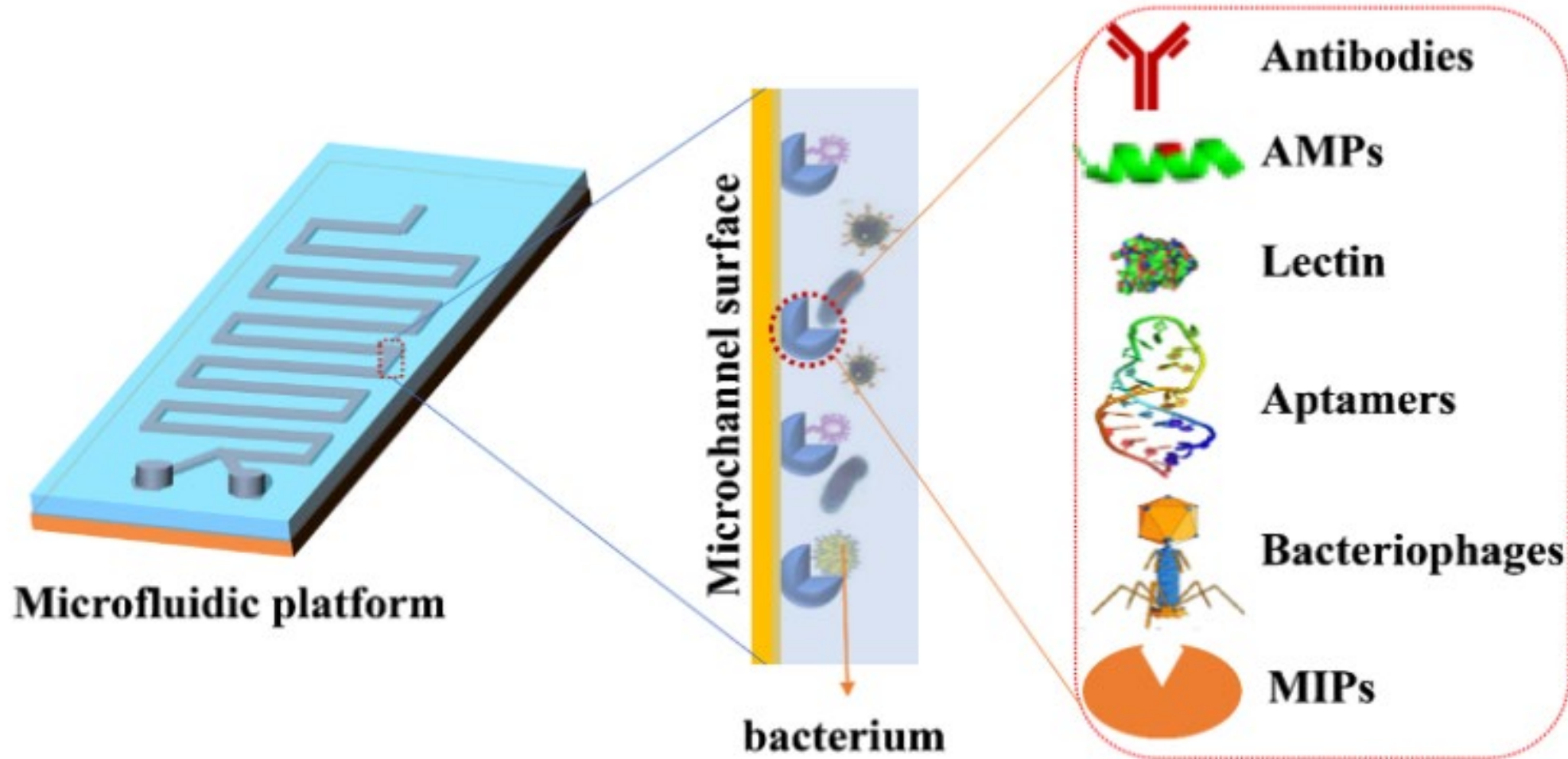

Mi, F., Hu, C., Wang, Y., Wang, L., Peng, F., Geng, P. and Guan, M., 2022. Recent advancements in microfluidic chip biosensor detection of foodborne pathogenic bacteria: a review. *Analytical and Bioanalytical Chemistry*, pp.1-20.

Project Proposal

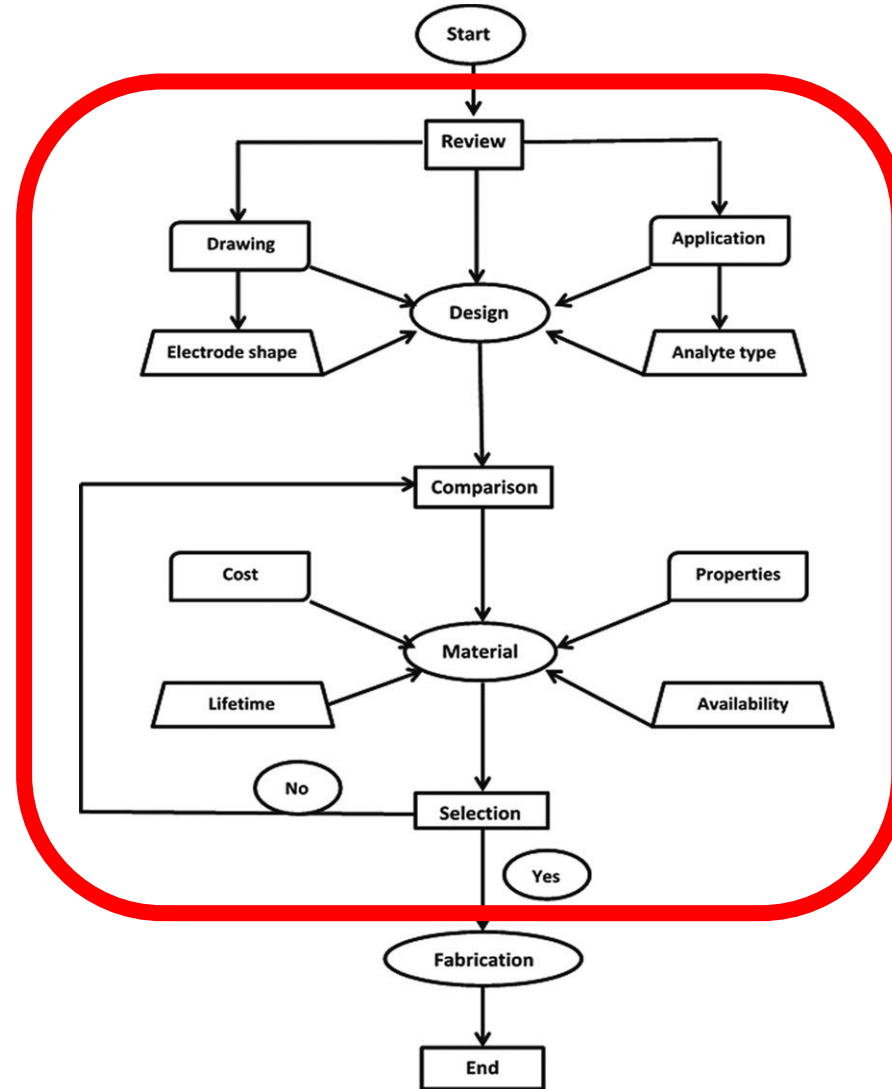

Abdulbari, Hayder A., and Esmail AM Basheer. "Electrochemical biosensors: electrode development, materials, design, and fabrication." *ChemBioEng Reviews* 4.2 (2017): 92-105.

Portable Breathalyzer for Exhaled Volatile Organic Compounds Monitoring in Lung Diseases

Alec Chevrot, Justina Venckute, Sarah Cuesta, Ata Golparvar, Amar Kopic, Gian Luca Barbruni*, Sandro Carrara
Integrated Circuit Laboratory (ICLAB), École Polytechnique Fédérale de Lausanne (EPFL), Neuchâtel, Switzerland

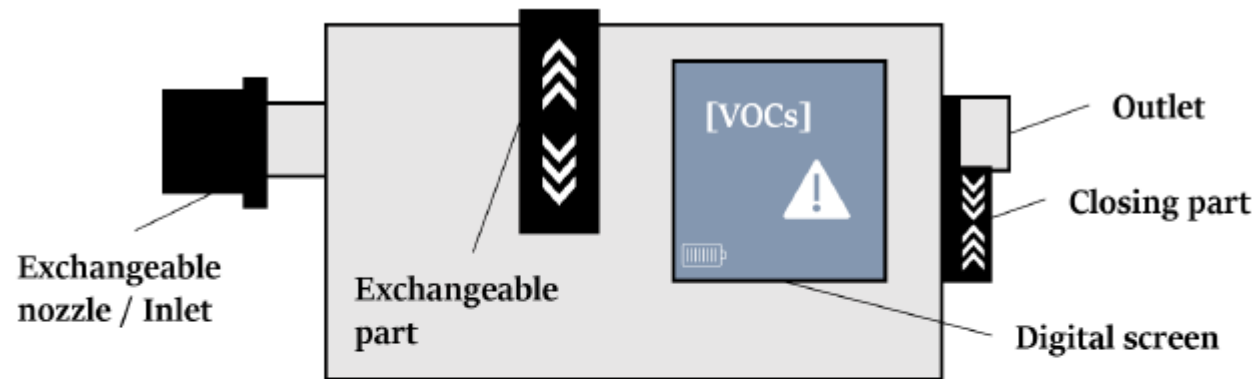

Fig. 1. The overall scheme of the proposed portable breathalyzer includes the exchangeable nozzle to enable sanitary operation by multiple users, an interchangeable sensor compartment for quick adjustment to enable different biomarker detection, and a segment display to ensure low-power operation when displaying the readings.

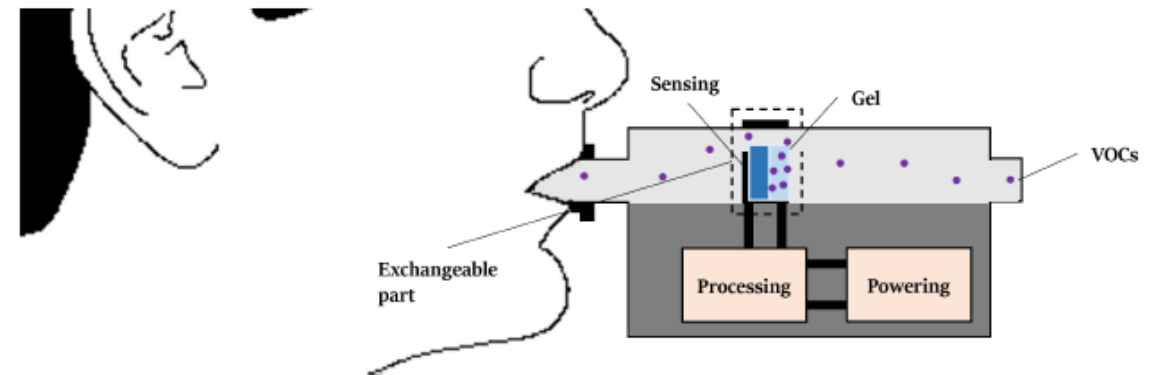

Fig. 2. The overall structure of the handheld breathalyzer during a typical application scenario. VOC are directly exhaled into the device. The flow is directed onto the exchangeable sensor compartment composed of agarose gel to collect VOC and an aptamer-based bio-nano interface to selectively detect the particular VOC of interest.

Projects Proposal - Hints

- Find idea based on personal interests/motivation
- Check recent review paper about the topic
- Search papers by keywords
- Check paper relevance: abstract/conclusions/tables
- Check references of the paper: might be useful!
- Tools: Google Scholar/IEEE Xplore/Nature

Project Proposal – Template

Name and Surname:

Section:

Previous Experience Checklist (put a check mark if applicable):

- Transistor-level Bi/CMOS circuit design
- PCB-level circuit design
- SPICE simulation software use (e.g., LTspice)
- Multiphysics finite element analysis software use (e.g., COMSOL)
- Microfluidics (design or simulation or fabrication)
- Development/simulation of a gas sensors
- Development/simulation of a magnetic or an optical sensor
- Development/simulation of an acoustic or an ultrasonic sensors

Title of the project (provisional):

Short description/summary (250 words max):

Sections you want to implement (1 sentence description for each):

- Bio:
- Nano:
- CMOS:
- Other (if applicable):

More Details:

- Application (250 words max):
- Motivation (250 words max):
- Problems to be solved (250 words max):
- Proposed solutions (250 words max):
- How will you implement your solution? (250 words max):
- Novelties of your proposal (Bullet points, each point 1 sentence):